

P4C1258

ULTRA HIGH SPEED 64K x 4

STATIC CMOS RAM



FEATURES

- Full CMOS, 6T Cell
- High Speed (Equal Access and Cycle Times)
 - 15/20/25/35 ns (Commercial/Industrial)
- Low Power
- Single 5V±10% Power Supply
- Data Retention with 2.0V Supply
- Three-State Outputs
- TTL/CMOS Compatible Outputs
- Fully TTL Compatible Inputs
- Standard Pinout (JEDEC Approved)
 - 24-Pin 300 mil DIP, SOJ



DESCRIPTION

The P4C1258 is a 262,144-bit ultra high speed static RAM organized as 64K x 4. The CMOS memory requires no clock or refreshing and has equal access and cycle times. Inputs and outputs are fully TTL-compatible. The RAM operates from a single 5V±10% tolerance power supply. With battery backup, data integrity is maintained for supply voltages down to 2.0V. Current drain is typically 10 µA from a 2.0V supply.

Access times as fast as 15 nanoseconds are available, permitting greatly enhanced system speeds. CMOS is utilized to reduce power consumption.

The P4C1258 is available in a 24-pin 300 mil DIP or SOJ packages providing excellent board level densities.



FUNCTIONAL BLOCK DIAGRAM

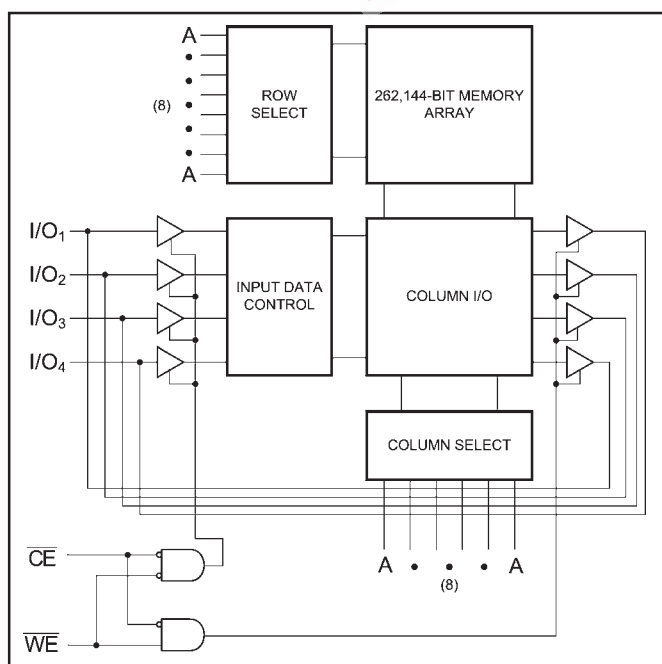

PIN CONFIGURATION

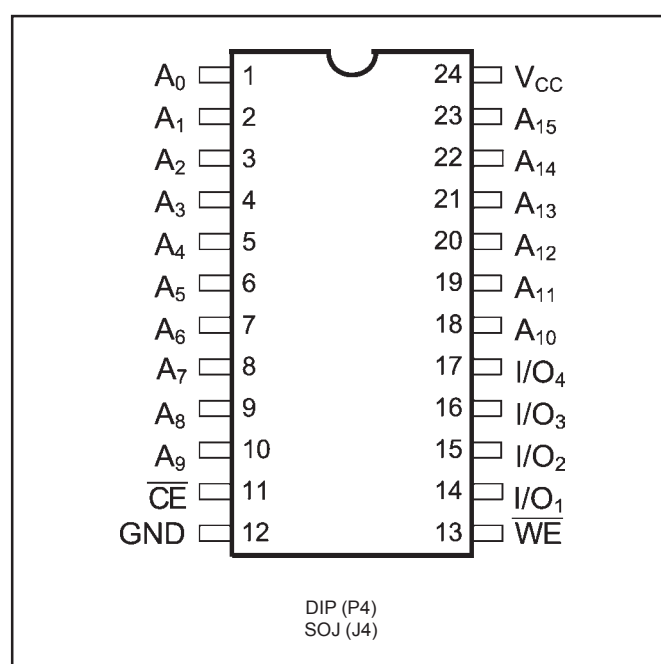

MAXIMUM RATINGS⁽¹⁾

Symbol	Parameter	Value	Unit
V_{CC}	Power Supply Pin with Respect to GND	-0.5 to +7	V
V_{TERM}	Terminal Voltage with Respect to GND (up to 7.0V)	-0.5 to $V_{CC} + 0.5$	V
T_A	Operating Temperature	-55 to +125	°C

Symbol	Parameter	Value	Unit
T_{BIAS}	Temperature Under Bias	-55 to +125	°C
T_{STG}	Storage Temperature	-65 to +150	°C
P_T	Power Dissipation	1.0	W
I_{OUT}	DC Output Current	50	mA

RECOMMENDED OPERATING TEMPERATURE AND SUPPLY VOLTAGE

Grade(2)	Ambient Temperature	GND	V_{CC}
Industrial	-40°C to +85°C	0V	5.0V ± 10%
Commercial	0°C to +70°C	0V	5.0V ± 10%

CAPACITANCES⁽⁴⁾

$V_{CC} = 5.0V$, $T_A = 25^\circ C$, $f = 1.0MHz$

Symbol	Parameter	Conditions	Typ.	Unit
C_{IN}	Input Capacitance	$V_{IN} = 0V$	5	pF
C_{OUT}	Output Capacitance	$V_{OUT} = 0V$	7	pF

DC ELECTRICAL CHARACTERISTICS

Over recommended operating temperature and supply voltage⁽²⁾

Symbol	Parameter	Test Conditions	P4C1258		Unit
			Min	Max	
V_{IH}	Input High Voltage		2.2	$V_{CC} + 0.5$	V
V_{IL}	Input Low Voltage		-0.5 ⁽³⁾	0.8	V
V_{HC}	CMOS Input High Voltage		$V_{CC} - 0.2$	$V_{CC} + 0.5$	V
V_{LC}	CMOS Input Low Voltage		-0.5 ⁽³⁾	0.2	V
V_{CD}	Input Clamp Diode Voltage	$V_{CC} = \text{Min.}, I_{IN} = 18 \text{ mA}$		-1.2	V
V_{OL}	Output Low Voltage (TTL Load)	$I_{OL} = +8 \text{ mA}, V_{CC} = \text{Min.}$		0.4	V
V_{OH}	Output High Voltage (TTL Load)	$I_{OH} = -4 \text{ mA}, V_{CC} = \text{Min.}$	2.4		V
I_{LI}	Input Leakage Current	$V_{CC} = \text{Max.}$ $V_{IN} = \text{GND to } V_{CC}$	-5	+5	µA
I_{LO}	Output Leakage Current	$V_{CC} = \text{Max.}, \overline{CE} = V_{IH}$ $V_{OUT} = \text{GND to } V_{CC}$	-5	+5	µA
I_{SB}	Standby Power Supply Current (TTL Input Levels)	$\overline{CE} \geq V_{IH}$ $V_{CC} = \text{Max.}, f = \text{Max.}, \text{Outputs Open}$	—	35	mA
I_{SB1}	Standby Power Supply Current (CMOS Input Levels)	$\overline{CE} \geq V_{HC}$ $V_{CC} = \text{Max.}, f = 0, \text{Outputs Open}$ $V_{IN} \leq V_{LC} \text{ or } V_{IN} \geq V_{HC}$	—	10	mA

Notes:

- Stresses greater than those listed under MAXIMUM RATINGS may cause permanent damage to the device. This is a stress rating only and functional operation of the device at these or any other conditions above those indicated in the operational sections of this specification is not implied. Exposure to MAXIMUM rating conditions for extended periods may affect reliability.
- Extended temperature operation guaranteed with 400 linear feet per minute of air flow.
- Transient inputs with V_{IL} and I_{IL} not more negative than -3.0V and -100mA, respectively, are permissible for pulse widths up to 20ns.
- This parameter is sampled and not 100% tested.

POWER DISSIPATION CHARACTERISTICS VS. SPEED

Symbol	Parameter	Temperature Range	-15	-20	-25	-35	Unit
			Commercial	160	125	115	
I _{CC}	Dynamic Operating Current*	Commercial	160	125	115	110	mA
		Industrial	170	135	120	115	mA

*V_{CC} = 5.5V. Tested with outputs open. f = Max. Switching inputs are 0V and 3V. $\overline{CE} = V_{IL}$

DATA RETENTION CHARACTERISTICS

Symbol	Parameter	Test Conditions	Min	Typ.*		Max		Unit
				V _{CC} = 2.0V	V _{CC} = 3.0V	V _{CC} = 2.0V	V _{CC} = 3.0V	
V _{DR}	V _{CC} for Data Retention		2.0					V
I _{CCDR}	Data Retention Current	$\overline{CE} \geq V_{CC} - 0.2V,$ $V_{IN} \geq V_{CC} - 0.2V$ or $V_{IN} \leq 0.2V$		10	15	1500	2000	μA
t _{CDR}	Chip Deselect to Data Retention Time		0					ns
t _R [†]	Operation Recovery Time		t _{RC} [§]					ns

*T_A = +125°C

§t_{RC} = Read Cycle Time

† This parameter is guaranteed but not tested.

DATA RETENTION WAVEFORM

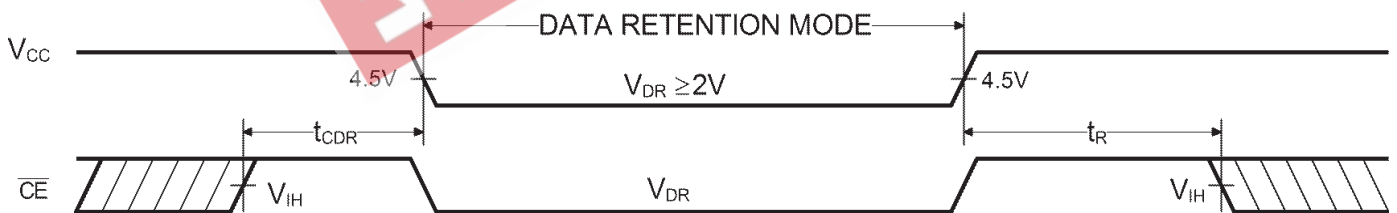

AC CHARACTERISTICS—READ CYCLE

($V_{CC} = 5V \pm 10\%$, All Temperature Ranges)⁽²⁾

Sym.	Parameter	-15		-20		-25		-35		Unit
		Min	Max	Min	Max	Min	Max	Min	Max	
t_{RC}	Read Cycle Time	15		20		25		35		ns
t_{AA}	Address Access Time		15		20		25		35	ns
t_{AC}	Chip Enable Access Time		15		20		25		35	ns
t_{OH}	Output Hold from Address Change	2		2		2		2		ns
t_{LZ}	Chip Enable to Output in Low Z	2		3		3		3		ns
t_{HZ}	Chip Disable to Output in High Z		8		9		10		11	ns
t_{PU}	Chip Enable to Power Up Time	0		0		0		0		ns
t_{PD}	Chip Disable to Power Down Time		15		20		25		35	ns

TIMING WAVEFORM OF READ CYCLE NO. 1⁽⁵⁾

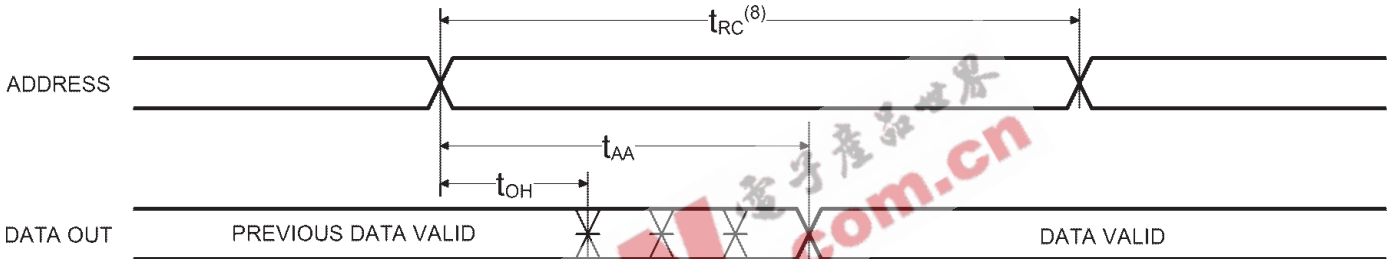

TIMING WAVEFORM OF READ CYCLE NO. 2⁽⁶⁾

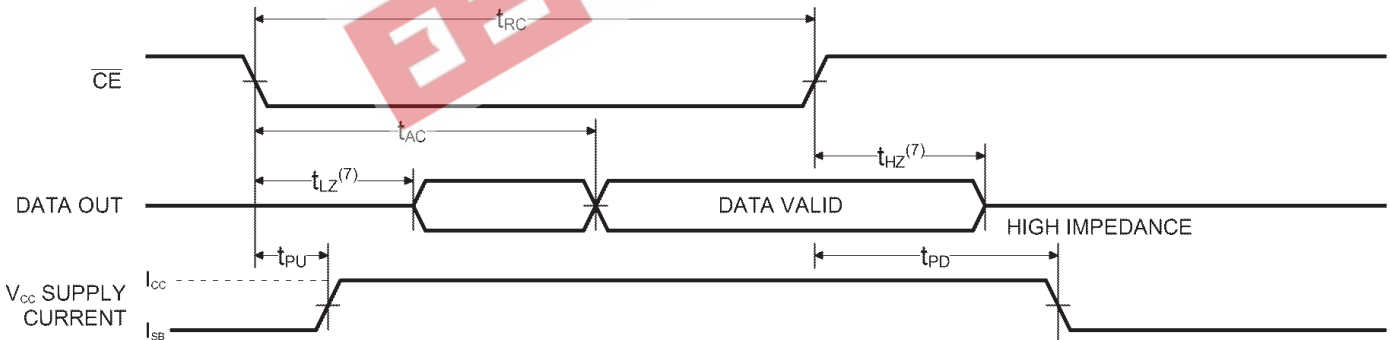

Notes:

- 5. \overline{CE} is LOW and \overline{WE} is HIGH for READ cycle.
- 6. \overline{WE} is HIGH, and address must be valid prior to or coincident with \overline{CE} transition LOW.

- 7. Transition is measured $\pm 200mV$ from steady state voltage prior to change with specified loading in Figure 1. This parameter is sampled and not 100% tested.
- 8. Read Cycle Time is measured from the last valid address to the first transitioning address.

AC CHARACTERISTICS - WRITE CYCLE

($V_{CC} = 5V \pm 10\%$, All Temperature Ranges)⁽²⁾

Sym.	Parameter	-15		-20		-25		-35		Unit
		Min	Max	Min	Max	Min	Max	Min	Max	
t_{WC}	Write Cycle Time	13		20		25		35		ns
t_{CW}	Chip Enable Time to End of Write	12		15		18		25		ns
t_{AW}	Address Valid to End of Write	12		15		18		25		ns
t_{AS}	Address Set-up Time	0		0		0		0		ns
t_{WP}	Write Pulse Width	12		15		18		25		ns
t_{AH}	Address Hold Time from End of Write	0		0		0		0		ns
t_{DW}	Data Valid to End of Write	7		8		10		15		ns
t_{DH}	Data Hold Time	0		0		0		0		ns
t_{WZ}	Write Enable to Output in High Z		6		8		10		15	ns
t_{DW}	Output Active from End of Write	2		2		2		3		ns

TIMING WAVEFORM OF WRITE CYCLE NO. 1 (WE CONTROLLED)⁽⁹⁾

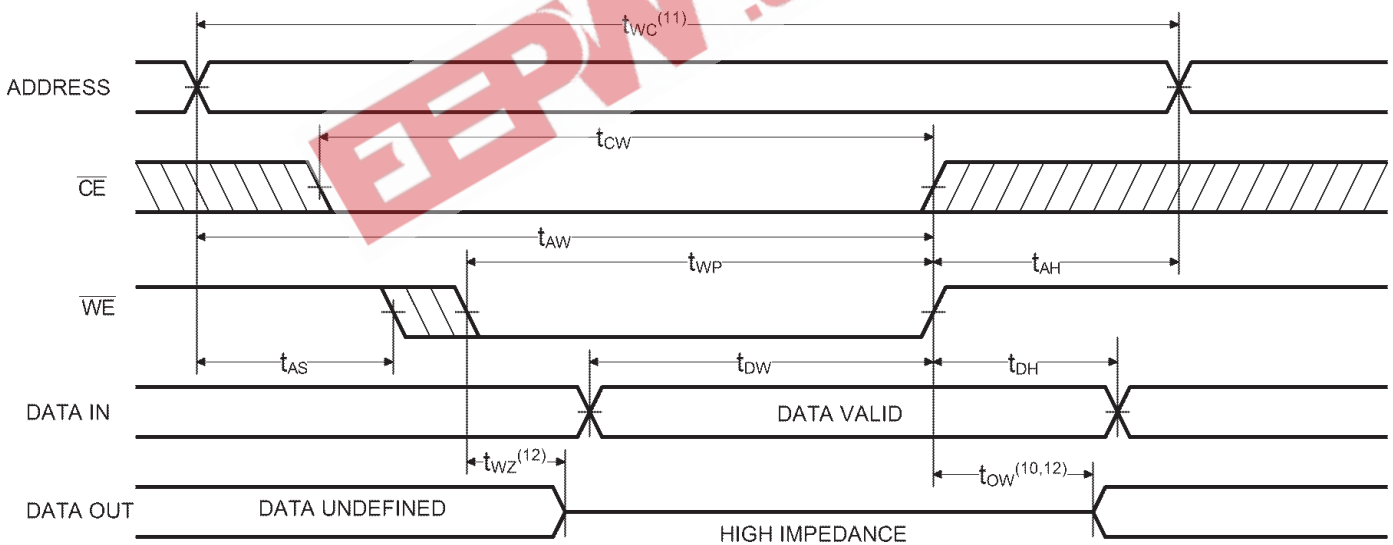

Notes:

9. \overline{CE} and \overline{WE} must be LOW for WRITE cycle.
10. If \overline{CE} goes HIGH simultaneously with \overline{WE} HIGH, the output remains in a high impedance state.
11. Write Cycle Time is measured from the last valid address to the first transition address.
12. Transition is measured $\pm 200\text{mV}$ from steady state voltage prior to change with specified loading in Figure 1. This parameter is sampled and not 100% tested.

TIMING WAVEFORM OF WRITE CYCLE NO. 2 (\overline{CE} CONTROLLED)⁽⁹⁾

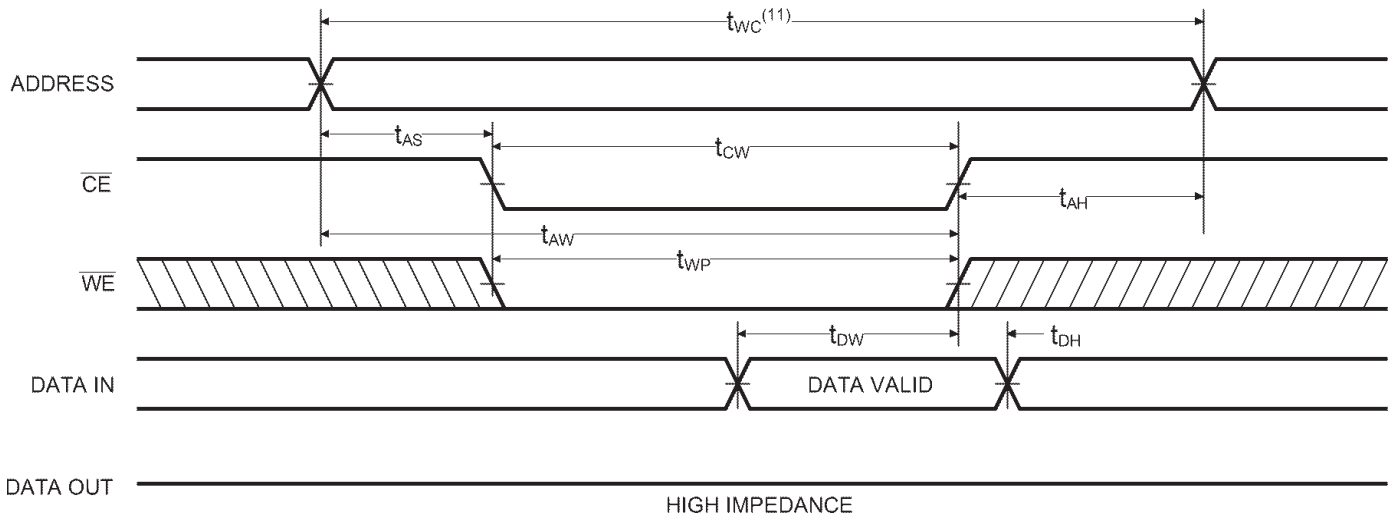

AC TEST CONDITIONS

Input Pulse Levels	GND to 3.0V
Input Rise and Fall Times	3ns
Input Timing Reference Level	1.5V
Output Timing Reference Level	1.5V
Output Load	See Figures 1 and 2

TRUTH TABLE

Mode	\overline{CE}	\overline{WE}	Output	Power
Standby	H	X	High Z	Standby
Read	L	H	D_{OUT}	Active
Write	L	L	D_{IN}	Active

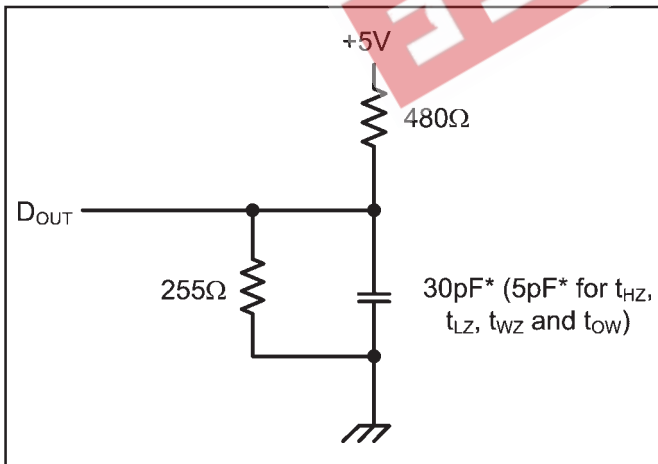

Figure 1. Output Load

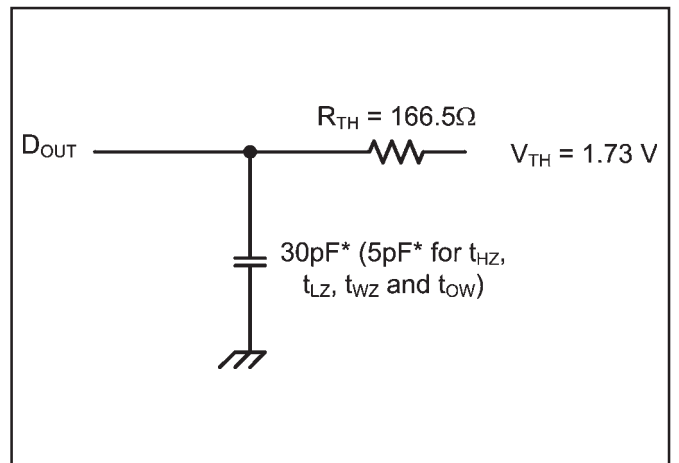

Figure 2. Thevenin Equivalent

* including scope and test fixture.

Note:

Because of the ultra-high speed of the P4C1258, care must be taken when testing this device; an inadequate setup can cause a normal functioning part to be rejected as faulty. Long high-inductance leads that cause supply bounce must be avoided by bringing the V_{CC} and ground planes directly up to the contactor fingers. A 0.01 μ F high

frequency capacitor is also required between V_{CC} and ground. To avoid signal reflections, proper termination must be used; for example, a 50 Ω test environment should be terminated into a 50 Ω load with 1.73V (Thevenin Voltage) at the comparator input, and a 116 Ω resistor must be used in series with D_{OUT} to match 166 Ω (Thevenin Resistance).

ORDERING INFORMATION

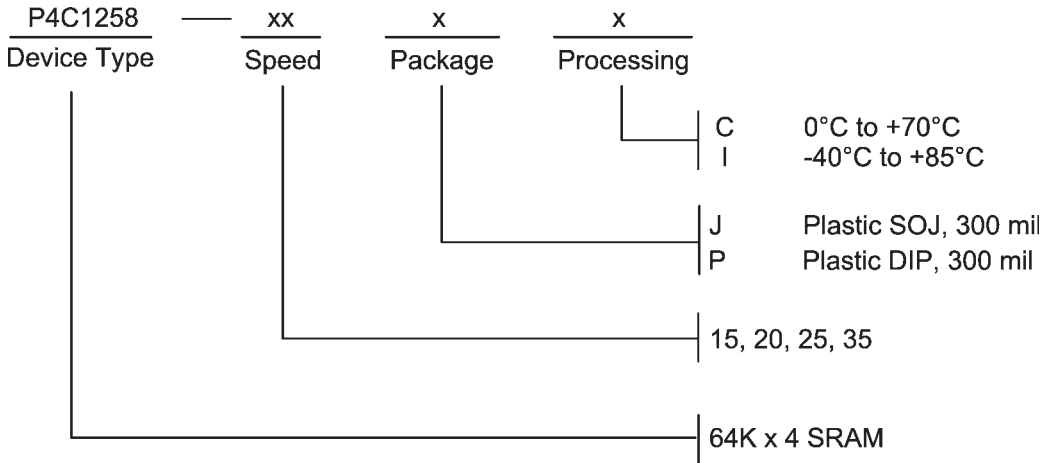

SELECTION GUIDE

The P4C1258 is available in the following temperature, speed and package options.

Temperature Range	Package	Speed			
		15	20	25	35
Commercial	Plastic DIP	-15PC	-20PC	-25PC	-35PC
	Plastic SOJ	-15JC	-20JC	-25JC	-35JC
Industrial	Plastic DIP	-15PI	-20PI	-25PI	-35PI
	Plastic SOJ	-15JI	-20JI	-25JI	-35JI

Pkg #	J4	
# Pins	24 (300 mil)	
Symbol	Min	Max
A	0.128	0.148
A1	0.082	-
b	0.016	0.020
C	0.007	0.010
D	0.620	0.630
e	0.050 BSC	
E	0.335 BSC	
E1	0.292	0.300
E2	0.267 BSC	
Q	0.025	-

SOJ SMALL OUTLINE IC PACKAGE

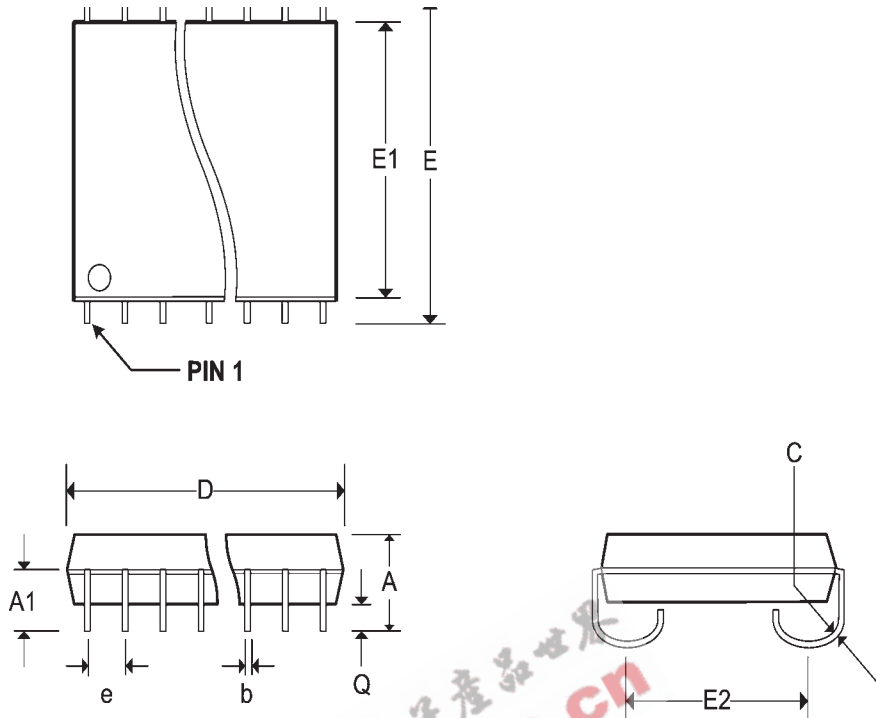

Pkg #	P4	
# Pins	24 (300 Mil)	
Symbol	Min	Max
A	-	0.210
A1	0.015	-
b	0.014	0.022
b2	0.045	0.070
C	0.008	0.014
D	1.230	1.280
E1	0.240	0.280
E	0.300	0.325
e	0.100 BSC	
eB	-	0.430
L	0.115	0.150
α	0°	15°

PLASTIC DUAL IN-LINE PACKAGE

