

4-bit MULTIFUNCTIONAL REAL TIME CLOCK MODULE

RTC-63421/63421M/63423

- Built-in crystal unit allows adjustment-free efficient operation.
- Alarm interruption of sec. to month and day of week possible.
- Provided with microcomputer compatible bus interface.
- Standard signal output selectable in a range of 10min. to 1024 Hz.
- Either sec. to hour and day of week or sec. to year and day of week is selectable.
- Reference area of time /alarm register is settable. Provided with RAM bits. (marked on "*" which is shown resistor table)
- Provided with START/STOP 30 second adjusting function.
- Similar mounting method (RTC-63423) to the used for normal type SMD IC.

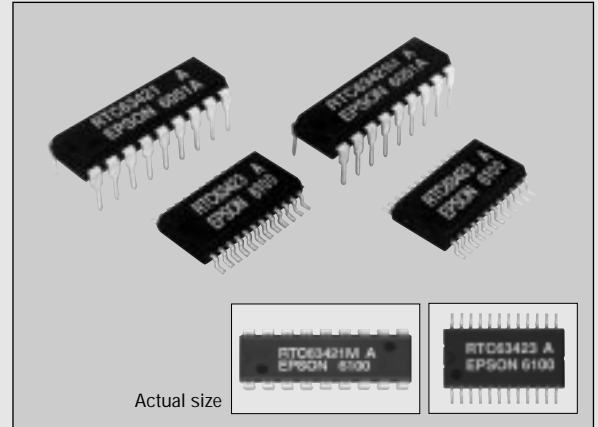

Model	Applicable CPU
RTC-63421	Intel bus system
RTC-63421M	Motorola bus system
RTC-63423	"MOTEL" bus system

Specifications (characteristics)

Absolute Max. rating

Item	Symbol	Condition	Specifications	Unit
Power source voltage	V _{DD}	T _a =25°C	-0.3 to 7.0	V
Input voltage	V _{IN}	T _a =25°C	-0.3 to V _{DD} +0.3	
storage temperature	T _{STG}	RTC-63421 RTC-63421M	-55 to +85	°C
		RTC-63423	-55 to +125	
Soldering condition	T _{SOL}	RTC-63421 RTC-63421M	Under 260°C within 10 sec. (lead part) (package should be less than 150°C)	
		RTC-63423	Twice at under 260°C within 10 sec. or under 230°C within 3 min.	

Operating range

Item	Symbol	Condition	Specifications	Unit
Operating voltage	V _{DD}		4.5 to 5.5	V
Operating temperature	T _{OPR}		-40 to +85	°C
Data holding voltage	V _{DH}		2.0 to 5.5	V
CS data holding time	t _{CDR}	Refer to the data holding timing	2.0 min.	µs
Operation restoring time	t _R			

Frequency characteristics and current consumption characteristics

Item	Symbol	Condition	Specifications	Unit	
Frequency tolerance	Δf/fo	T _a =25°C V _{DD} =5V	63421A/63421MA	+15/-5 (5±10)	ppm
			63421B/63421MB	+55/-45 (5±50)	
			63423 A	+25/-15 (5±20)	
			63423	+55/-45 (5±50)	
Frequency temperature characteristics		+10 to +70°C (25°C reference temperature)	+10/-120		
		-30 to +85°C (25°C reference temperature)	+10/-220		
Aging	f _a	V _{DD} =5V, T _a =25°C, first year	±5 max.	ppm/Y	
Shock resistance	S.R.	Three drops on a hard board from 75 cm or 3000G x 0.3ms x 1/2 sine wave x 3 directions	±10 max.	ppm	
Current consumption	I _{DD1}	CS ₁ =0V	V _{DD} =5V	30max.	µA
	I _{DD2}		V _{DD} =2V	1.8 max.	

Unless otherwise stated, characteristics (specifications) shown in the above table are based on the rated operating temperature and voltage condition.

Terminal connection

RTC-63421/63421M

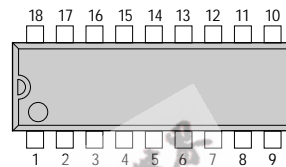

RTC-63423

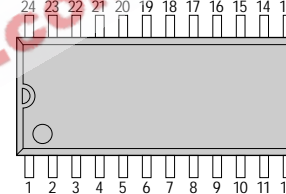

No.	63421/63421M	No.	63423
1	INTERRUPT	1	INTERRUPT
2	CS ₀	2	CS ₀
3	ALE	3	ALARM
4	A ₀	4	ALE
5	A ₁	5	A ₀
6	A ₂	6	30sec.Adj
7	A ₃	7	A ₁
8	RD (E #1)	8	68/80
9	GND	9	A ₂
10	WR (R/W #1)	10	A ₃
11	D ₃	11	RD (E #2)
12	D ₂	12	GND
13	D ₁	13	WR (R/W #2)
14	D ₀	14	D ₃
15	CS ₁	15	D ₂
16	(V _{DD})	16	D ₁
17	(V _{DD})	17	1Hz
18	V _{DD}	18	D ₀
		19	CS ₁
		20	STOP/START
		21	NC
		22	(V _{DD})
		23	(V _{DD})
		24	V _{DD}

* 1=63421M

* 2=Motorola bus system

- (V_{DD}) is to be same level as V_{DD}. Do not connect it to any external terminals.
- NC is not connected internally.

External dimensions

(Unit: mm)

RTC-63421/63421M

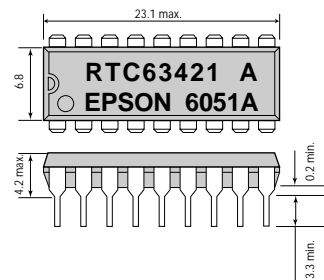

RTC-63423

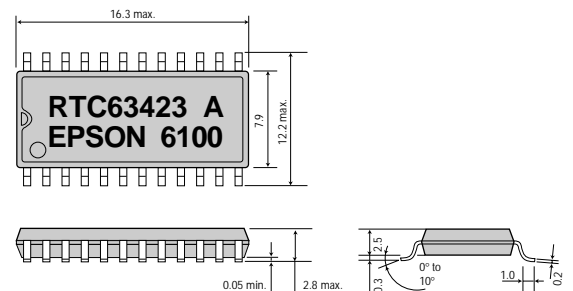

Data holding timing

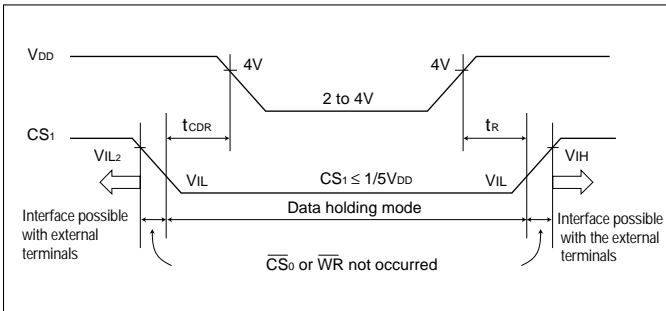

Register table

Address	Symbol of register	BANK 0				Real time register name
		D ₃	D ₂	D ₁	D ₀	
0	R-S ₁	r-S ₈	r-S ₄	r-S ₂	r-S ₁	1 - sec. digit register
1	R-S ₁₀	*	r-S ₄₀	r-S ₂₀	r-S ₁₀	10 - sec. digit register
2	R-MI ₁	r-mi ₈	r-mi ₄	r-mi ₂	r-mi ₁	1 - min. digit register
3	R-MI ₁₀	*	r-mi ₄₀	r-mi ₂₀	r-mi ₁₀	10 - min. digit register
4	R-H ₁	r-h ₈	r-h ₄	r-h ₂	r-h ₁	1 - hour digit register
5	R-H ₁₀	*	r-PM/AM	r-h ₂₀	r-h ₁₀	10 - hour digit register
6	R-D ₁	r-d ₈	r-d ₄	r-d ₂	r-d ₁	1 - day digit register
7	R-D ₁₀	*		r-d ₂₀	r-d ₁₀	10 - day digit register
8	R-MO ₁	r-mo ₈	r-mo ₄	r-mo ₂	r-mo ₁	1 - month digit register
9	R-MO ₁₀	*			r-mo ₁₀	10 - month digit register
A	R-Y ₁	r-y ₈	r-y ₄	r-y ₂	r-y ₁	1 - year digit register
B	R-Y ₁₀	r-y ₈₀	r-y ₄₀	r-y ₂₀	r-y ₁₀	10 - year digit register
C	R-W	*	r-w ₄	r-w ₂	r-w ₁	Week register
D	C _D	IT/PLS ₂	IT/PLS ₁	MASK ₂	MASK ₁	Control register D
E	C _E	IRQ · FLAG ₀	RESET	IRQ · FLAG ₂	IRQ · FLAG ₁	Control register E
F	C _F	BANK ₁ BANK ₀	STOP	30 sec. ADJ	READ FLAG	Control register F

Symbol of register	BANK 1				Alarm register name
	D ₃	D ₂	D ₁	D ₀	
A-S ₁	a-S ₈	a-S ₄	a-S ₂	a-S ₁	1 - sec. digit register
A-S ₁₀	*	a-S ₄₀	a-S ₂₀	a-S ₁₀	10 - sec. digit register
A-MI ₁	a-mi ₈	a-mi ₄	a-mi ₂	a-mi ₁	1 - min. digit register
A-MI ₁₀	*	a-mi ₄₀	a-mi ₂₀	a-mi ₁₀	10 - min. digit register
A-H ₁	a-h ₈	a-h ₄	a-h ₂	a-h ₁	1 - hour digit register
A-H ₁₀	*	a-PM/AM	a-h ₂₀	a-h ₁₀	10 - hour digit register
A-D ₁	a-d ₈	a-d ₄	a-d ₂	a-d ₁	1 - day digit register
A-D ₁₀	*		a-d ₂₀	a-d ₁₀	10 - day digit register
A-MO ₁	a-mo ₈	a-mo ₄	a-mo ₂	a-mo ₁	1 - month digit register
A-MO ₁₀	*			a-mo ₁₀	10 - month digit register
A-W	*	r-w ₄	a-w ₂	a-w ₁	Week register
A-EMB	ae ₈	ae ₄	ae ₂	ae ₁	Area define register
C _c	*		TEST ₂	TEST ₁	Test register
C _D	*	CY ₂	CY ₁	CY ₀	Control register D
C _E	HD/SFT	24/12	CAL	D · P	Control register E
C _F	Same as BANK 0				Control register F

Switching characteristics

Motorola bus system (V_{DD} = 5V ± 0.5V, T_a = 0 to + 70°C)

Item	Symbol	Min.	Max.	Unit
R/W, address setup time	t _{RWE}	100		ns
E "H" pulse width	t _{EHW}	220		
R/W, address hold time	t _{ERW}	20		
E "L" pulse width	t _{ELW}	220		
E cycle time	t _{EC}	500		
DATA setup time	t _{DS}	180		
DATA hold time	t _{DH}	20		
E to data (CL=150pF)	t _{RD}	—	120	
Data hold	t _{ED}	10	—	

Switching characteristics on the Intel bus system are the same as those for the RTC-6242 series.

Write mode

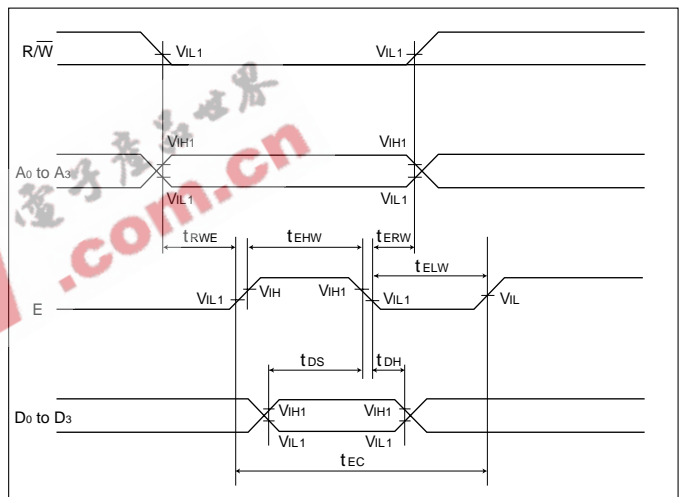

Read mode

