

4-bit REAL TIME CLOCK MODULE

RTC-62421/62423

- Built-in crystal unit allows adjustment-free efficient operation.
- Low standby voltage and current consumption (1.8μA at 2V).
- Wide range of operating temperature (from -40°C to +85°C).
- 24H/12H changeable and leap year automatically adjustable (gregorian calendar).
- Similar mounting method (RTC-62423) to that used for universal type SMD IC.
- Pins and functions are compatible with the MSM6242 series.

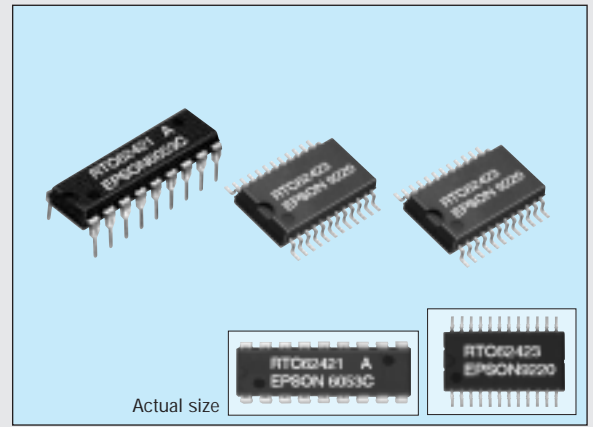

Specifications (characteristics)

Absolute Max. rating

Item	Symbol	Condition	Specifications	Unit
Power source voltage	V _{DD}	Ta=25°C	-0.3 to 7.0	V
Input and output voltage	V _{I/O}		-0.3 to V _{DD} +0.3	
Storage temperature	T _{STG}	RTC-62421	-55 to +85	°C
		RTC-62423	-55 to +125	
Soldering condition	T _{SOL}	RTC-62421	Under 260°C within 10 sec. (lead part) (package should be less than 150°C)	
		RTC-62423	Twice at under 260°C within 10 sec. or under 230°C within 3 min.	

Operating range

Item	Symbol	Condition	Specifications	Unit
Operating voltage	V _{DD}		4.5 to 5.5	V
Operating temperature	T _{OPR}		-40 to +85	°C
Data holding voltage	V _{DH}		2.0 to 5.5	V
CS ₁ data holding time	t _{CDH}	Refer to the data holding timing	2.0 min.	μs
Operation restoring time	t _R			

Frequency characteristics and current consumption characteristics

Item	Symbol	Condition	Specifications	Unit	
Frequency tolerance	Δf/fo	Ta=25°C V _{DD} =5V	62421 A	±10	ppm
			62421 B	±50	
			62423 A	±20	
			62423	±50	
Frequency temperature characteristics		-10 to +70°C (25°C reference temperature)	+10/-120		
		-40 to +85°C (25°C reference temperature)	+10/-220		
Aging	f _a	V _{DD} =5V, Ta=25°C, first year	±5 max.	ppm/Y	
Shock resistance	S.R.	Three drops on a hard board from 75 cm or 3000G x 0.3ms x 1/2 sine wave x 3 directions	±10 max.	ppm	
Current consumption	I _{DD1}	CS ₁ =0V	V _{DD} =5V	30 max.	μA
	I _{DD2}		V _{DD} =2V	1.8 max.	

Electrical characteristics

Item	Symbol	Condition	Min.	Typ.	Max.	Unit	Applicable terminal
"H" input voltage (1)	V _{IH1}	—	2.2	—	—	V	All inputs other than CS ₁
"L" input voltage (1)	V _{IL1}						
Input leak current (1)	I _{LK1}	V ₁ =V _{DD} /OV	—	—	1/-1	μA	Input other than D ₀ to D ₃
Input leak current (2)	I _{LK2}				10/-10		
"L" output voltage (1)	V _{OL1}	I _{OL} =2.5mA	—	—	0.4	V	D ₀ to D ₃
"H" output voltage	V _{OH}						
"L" output voltage (2)	V _{OL2}	I _{OL} =2.5mA	—	—	0.4	V	STD.P
OFF leak current	I _{OFFLK}						
Input capacity	C ₁	Input frequency 1 MHz	—	5	—	pF	
"H" input voltage (2)	V _{IH2}	V _{DD} =2 to 5.5V	4/5 V _{DD}	—	—	V	CS ₁
"L" input voltage (2)	V _{IL2}						

Terminal connection

RTC-62421

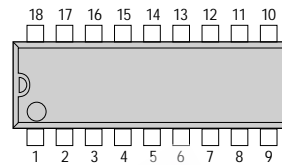

No.	62421	No.	62423
1	STD. P	1	STD. P
2	CS ₁	2	CS ₁
3	ALE	3	NC
4	A ₀	4	ALE
5	A ₁	5	A ₀
6	A ₂	6	NC
7	A ₃	7	A ₁
8	RD	8	NC
9	GND	9	A ₂
10	WR	10	A ₃
11	D ₃	11	RD
12	D ₂	12	GND
13	D ₁	13	WR
14	D ₀	14	D ₂
15	CS ₁	15	D ₂
16	(V _{DD})	16	D ₁
17	(V _{DD})	17	NC
18	V _{DD}	18	NC
		19	D ₀
		20	CS ₁
		21	NC
		22	(V _{DD})
		23	(V _{DD})
		24	V _{DD}

RTC-62423

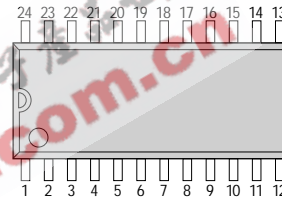

- (V_{OE}) and V_{DD} are to have the same level of voltage. Do not connect it to any external terminals.
- NC is not connected internally.

External dimensions

(Unit: mm)

RTC-62421

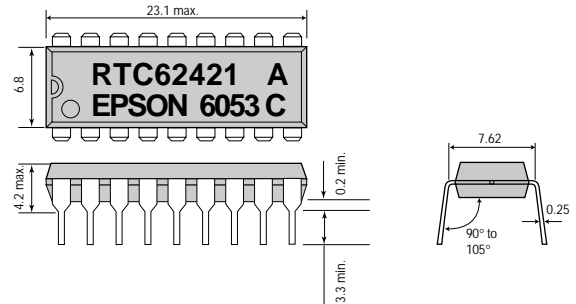

RTC-62423

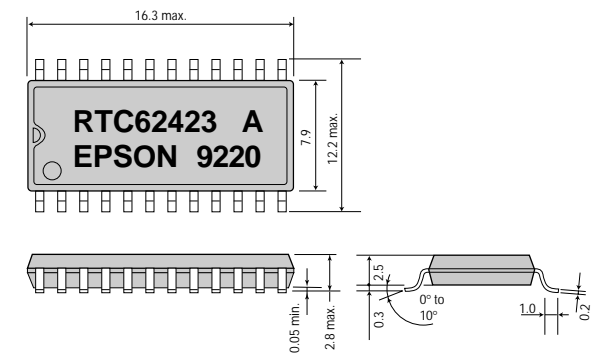

Data holding timing

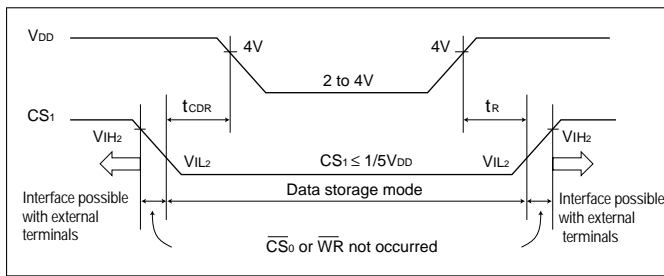

Register table

Address	A ₃	A ₂	A ₁	A ₀	Name of register	D ₃	D ₂	D ₁	D ₀	Count	Note
0	0	0	0	0	S ₁	S ₈	S ₄	S ₂	S ₁	0 to 9	1 - sec. digit register
1	0	0	0	1	S ₁₀	*	S ₄₀	S ₂₀	S ₁₀	0 to 5	10 - sec. digit register
2	0	0	1	0	M ₁	mi ₈	mi ₄	mi ₂	mi ₁	0 to 9	1 - min. digit register
3	0	0	1	1	M ₁₀	*	mi ₄₀	mi ₂₀	mi ₁₀	0 to 5	10 - min. digit register
4	0	1	0	0	H ₁	h ₈	h ₄	h ₂	h ₁	0 to 9	1 - hour digit register
5	0	1	0	1	H ₁₀	*	PM/AM	h ₂₀	H ₁₀	0 to 2 or 0 to 1	10 - hour digit register
6	0	1	1	0	D ₁	d ₈	d ₄	d ₂	d ₁	0 to 9	1 - day digit register
7	0	1	1	1	D ₁₀	*		d ₂₀	d ₁₀	0 to 3	10 - day digit register
8	1	0	0	0	MO ₁	mo ₈	mo ₄	mo ₂	mo ₁	0 to 9	1 - month digit register
9	1	0	0	1	MO ₁₀	*			mo ₁₀	0 to 1	10 - month digit register
A	1	0	1	0	Y ₁	y ₈	y ₄	y ₂	y ₁	0 to 9	1 - year digit register
B	1	0	1	1	Y ₁₀	y ₈₀	y ₄₀	y ₂₀	y ₁₀		10 - year digit register
C	1	1	0	0	W	*	W ₄	W ₂	W ₁	0 to 6	Week register
D	1	1	0	1	C _D	30 sec. ADJ	IRQ FLAG	BUSY	HOLD		Control register D
E	1	1	1	0	C _E	t ₁	t ₀	ITRPT/STND	MASK		Control register E
F	1	1	1	1	C _F	TEST	24/12	STOP	RESET		Control register F

Supplement

0="L" level. 1="H" level

	PM/AM	24/12	ITRPT/STND
1	PM	24	ITRPT
0	AM	12	STND

Bit name	Description
* mark	Writable. Recognized as 0 while in read mode.
BUSY	Read only (effective only when HOLD=1)
IRQ FLAG	Enter "0" only when clearing interruption. Enter "1" otherwise.
24H/12H	Set able only when RESET=1
TEST	For our company's testing. TEST should be "0" in normal use.

Note: Do not enter erroneous data for clock. This may result in time keeping error.

Block diagram

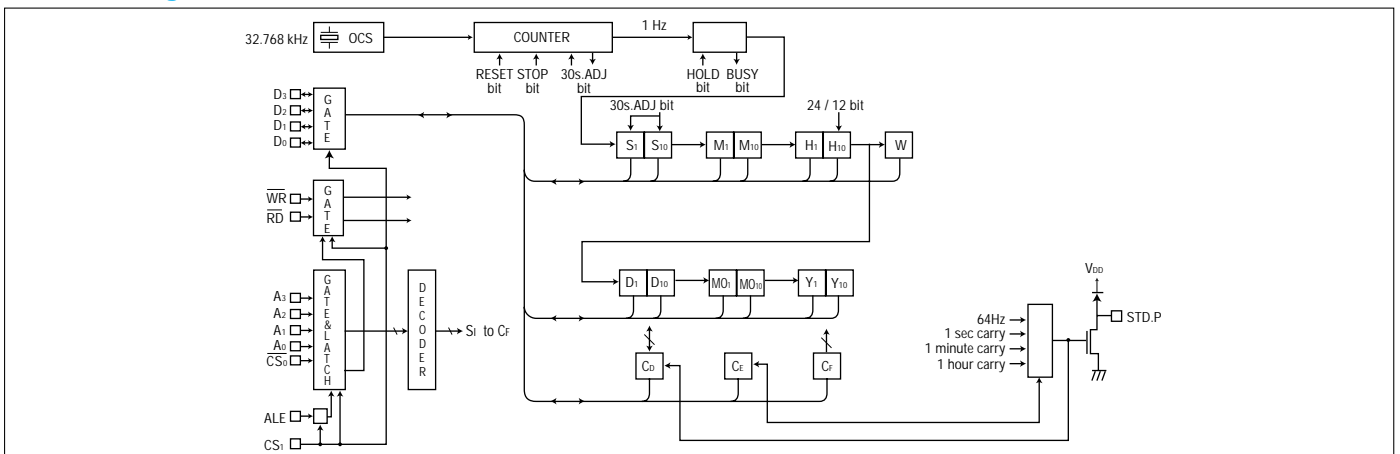

Switching characteristics (V_{DD} = 5V ± 0.5V, Ta = -40 to +85°C)
(ALE = While in use)

Item	Symbol	Condition	Min.	Max.	Unit
CS ₁ setup time	t _{CIS}		1000		ns
CS ₁ hold time	t _{CH}		1000		
Address setup time	t _{AS}		25		
Address hold time	t _{AH}		25		
ALE pulse width	t _{AW}	—	40	—	
ALE before WRITE	t _{ALW}		10		
ALE before READ	t _{ALR}		10		
ALE after WRITE	t _{WAL}		20		
ALE after READ	t _{RAL}		10		
WRITE pulse width	t _{WW}		120		
RD to data	t _{RD}	CL=150pF		120	
DATA hold	t _{DR}		0	45	
DATA setup time	t _{DS}	—	100		
DATA hold time	t _{DH}		10	—	
RD/WR recovery time	t _{RCV}		60		

Write mode

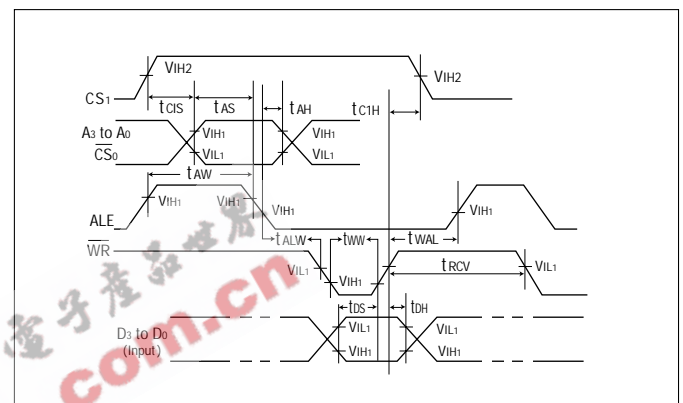

Read mode

