

# SN5485, SN54LS85, SN54S85 SN7485, SN74LS85, SN74S85 4-BIT MAGNITUDE COMPARATORS

SDLS123 - MARCH 1974 - REVISED MARCH 1988

TYPE	TYPICAL POWER DISSIPATION	TYPICAL DELAY (4-BIT WORDS)
'85	275 mW	23 ns
'LS85	52 mW	24 ns
'S85	365 mW	11 ns

SN5485, SN54LS85, SN54S85 . . . J OR W PACKAGE  
SN7485 . . . N PACKAGE

SN74LS85, SN74S85 . . . D OR N PACKAGE

(TOP VIEW)

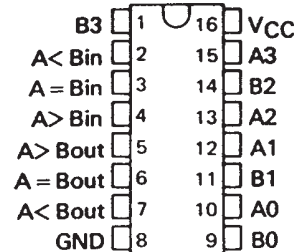

SN54LS85, SN54S85 . . . FK PACKAGE

(TOP VIEW)

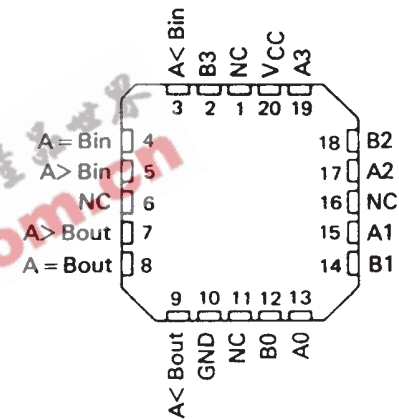

NC - No internal connection

## description

These four-bit magnitude comparators perform comparison of straight binary and straight BCD (8-4-2-1) codes. Three fully decoded decisions about two 4-bit words (A, B) are made and are externally available at three outputs. These devices are fully expandable to any number of bits without external gates. Words of greater length may be compared by connecting comparators in cascade. The A > B, A < B, and A = B outputs of a stage handling less-significant bits are connected to the corresponding A > B, A < B, and A = B inputs of the next stage handling more-significant bits. The stage handling the least-significant bits must have a high-level voltage applied to the A = B input. The cascading paths of the '85, 'LS85, and 'S85 are implemented with only a two-gate-level delay to reduce overall comparison times for long words. An alternate method of cascading which further reduces the comparison time is shown in the typical application data.

FUNCTION TABLE

COMPARING INPUTS				CASCADING INPUTS			OUTPUTS		
A3, B3	A2, B2	A1, B1	A0, B0	A > B	A < B	A = B	A > B	A < B	A = B
A3 > B3	X	X	X	X	X	X	H	L	L
A3 < B3	X	X	X	X	X	X	L	H	L
A3 = B3	A2 > B2	X	X	X	X	X	H	L	L
A3 = B3	A2 < B2	X	X	X	X	X	L	H	L
A3 = B2	A2 = B2	A1 > B1	X	X	X	X	H	L	L
A3 = B3	A2 = B2	A1 < B1	X	X	X	X	L	H	L
A2 = B3	A2 = B2	A1 = B1	A0 > B0	X	X	X	H	L	L
A3 = B3	A2 = B2	A1 = B1	A0 < B0	X	X	X	L	H	L
A3 = B3	A2 = B2	A1 = B1	A0 = B0	H	L	L	H	L	L
A3 = B3	A2 = B2	A1 = B1	A0 = B0	L	H	L	L	H	L
A3 = B3	A2 = B2	A1 = B1	A0 = B0	X	X	H	L	L	H
A3 = B3	A2 = B2	A1 = B1	A0 = B0	H	H	L	L	L	L
A3 = B3	A2 = B2	A1 = B1	A0 = B0	L	L	L	H	H	L

SN5485, SN54LS85, SN54S85  
 SN7485, SN74LS85, SN74S85  
 4-BIT MAGNITUDE COMPARATORS

SDLS123 - MARCH 1974 - REVISED MARCH 1988

logic diagrams (positive logic)

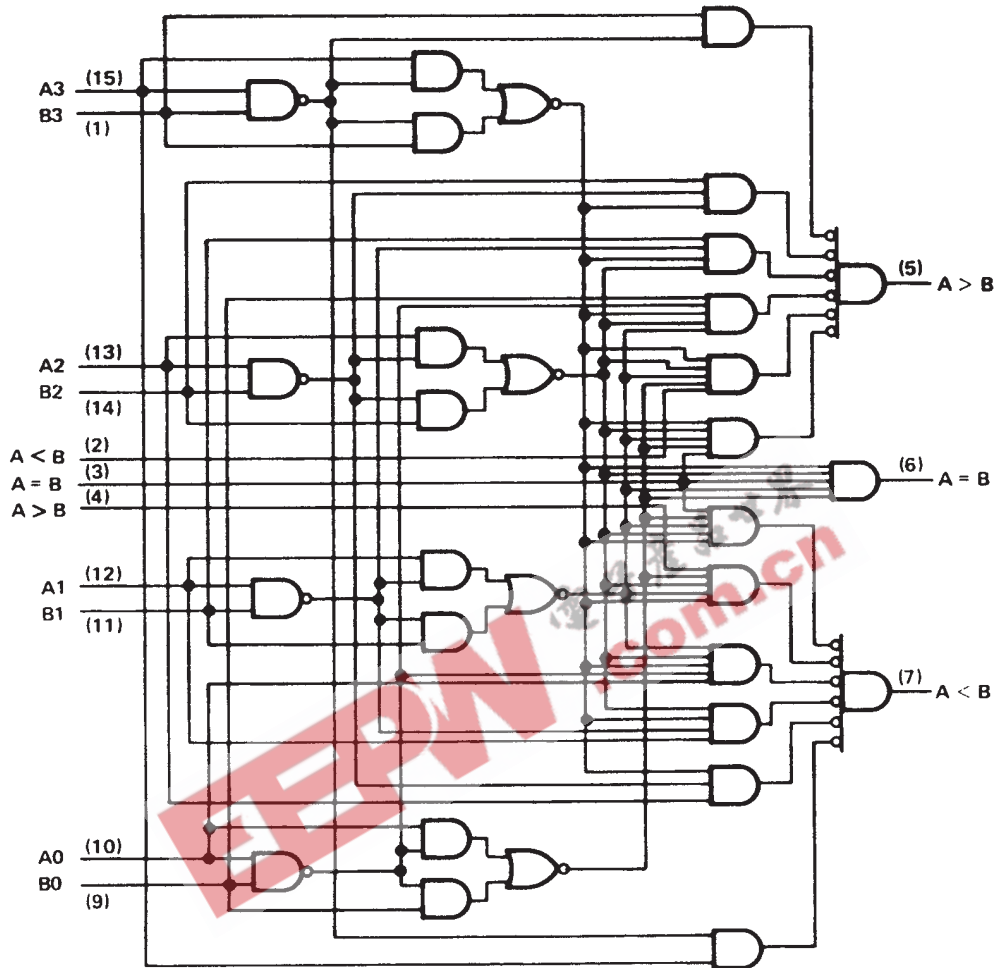

logic symbol†

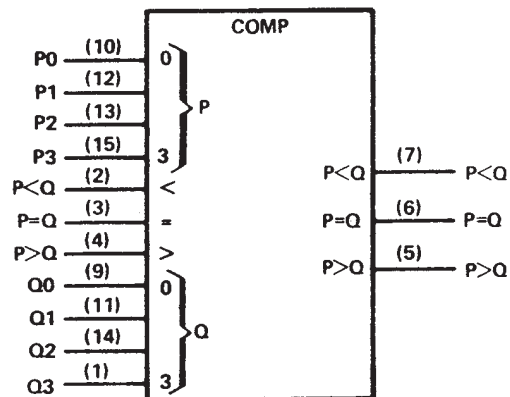

†This symbol is in accordance with ANSI/IEEE Std 91-1984 and IEC Publication 617-12. Pin numbers shown are for D, J, N, and W packages.

SN5485, SN54LS85, SN54S85  
 SN7485, SN74LS85, SN74S85  
**4-BIT MAGNITUDE COMPARATORS**  
 SDLS123 – MARCH 1974 – REVISED MARCH 1988

schematics of inputs and outputs

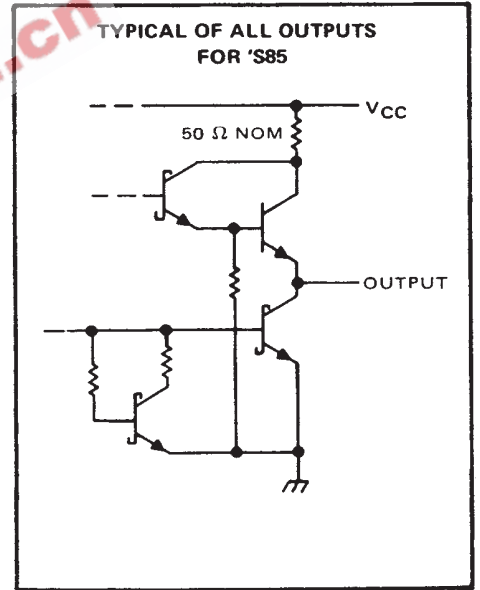
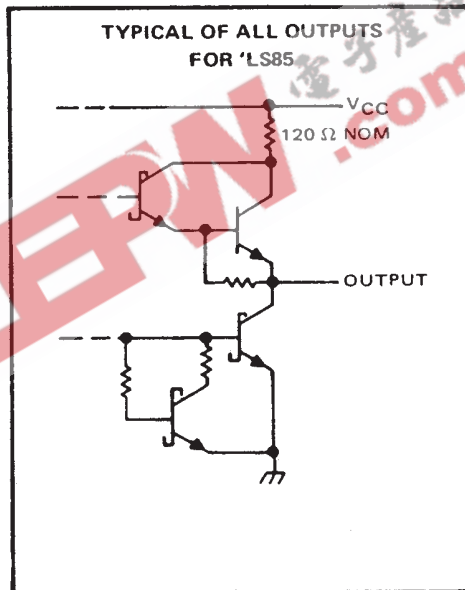
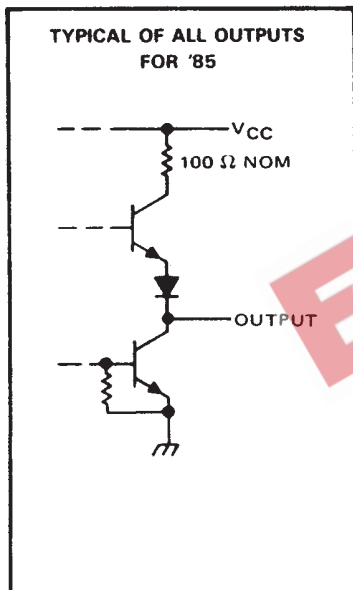
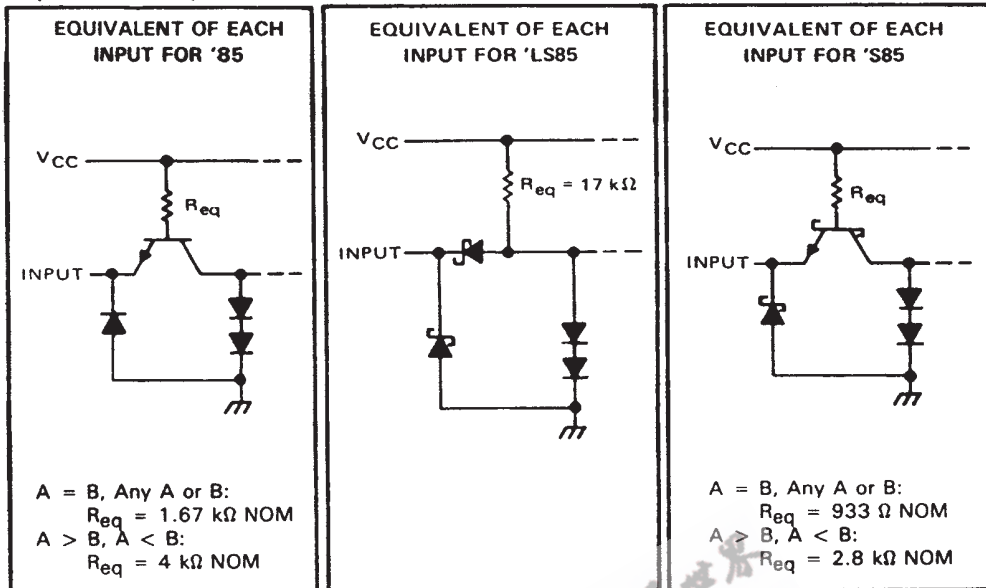

absolute maximum ratings over operating free-air temperature range (unless otherwise noted)

	SN54' SN54S'	SN54LS'	SN74' SN74S'	SN74LS'	UNIT
Supply voltage, $V_{CC}$ (see Note 1)	7	7	7	7	V
Input voltage	5.5	7	5.5	7	V
Interemitter voltage (see Note 2)	5.5		5.5		V
Operating free-air temperature range	-55 to 125		-0 to 70		°C
Storage temperature range	-65 to 150		-65 to 150		°C

- NOTES: 1. Voltage values, except interemitter voltage, are with respect to network ground terminal.  
 2. This is the voltage between two emitters of a multiple-emitter input transistor. This rating applies to each A input in conjunction with its respective B input of the '85 and 'S85.

SN5485, SN54LS85, SN54S85  
 SN7485, SN74LS85, SN74S85  
 4-BIT MAGNITUDE COMPARATORS

SDLS123 – MARCH 1974 – REVISED MARCH 1988

recommended operating conditions

	SN5485			SN7485			UNIT
	MIN	NOM	MAX	MIN	NOM	MAX	
Supply voltage, $V_{CC}$	4.5	5	5.5	4.75	5	5.25	V
High-level output current, $I_{OH}$			-400			-400	$\mu$ A
Low-level output current, $I_{OL}$			16			16	mA
Operating free-air temperature, $T_A$	-55		125	0		70	$^{\circ}$ C

electrical characteristics over recommended operating free-air temperature range (unless otherwise noted)

PARAMETER		TEST CONDITIONS <sup>†</sup>	MIN	TYP <sup>‡</sup>	MAX	UNIT
$V_{IH}$	High-level input voltage		2			V
$V_{IL}$	Low-level input voltage				0.8	V
$V_{IK}$	Input clamp voltage	$V_{CC} = \text{MIN}$ , $I_I = -12 \text{ mA}$			-1.5	V
$V_{OH}$	High-level output voltage	$V_{CC} = \text{MIN}$ , $V_{IL} = 0.8 \text{ V}$ , $I_{OH} = -400 \mu\text{A}$	2.4	3.4		V
$V_{OL}$	Low-level output voltage	$V_{CC} = \text{MIN}$ , $V_{IL} = 0.8 \text{ V}$ , $I_{OL} = 16 \text{ mA}$		0.2	0.4	V
$I_I$	Input current at maximum input voltage	$V_{CC} = \text{MAX}$ , $V_I = 5.5 \text{ V}$			1	mA
$I_{IH}$	High-level input current	A < B, A > B inputs			40	$\mu$ A
		all other inputs			120	
$I_{IL}$	Low-level input current	A < B, A > B inputs			-1.6	mA
		all other inputs			-4.8	
$I_{OS}$	Short-circuit output current <sup>§</sup>	$V_{CC} = \text{MAX}$ , $V_O = 0$	SN5485	-20	-55	mA
			SN7485	-18	-55	
$I_{CC}$	Supply current	$V_{CC} = \text{MAX}$ , See Note 4		55	88	mA

<sup>†</sup> For conditions shown as MIN or MAX, use the appropriate value specified under recommended operating conditions.

<sup>‡</sup> All typical values are at  $V_{CC} = 5 \text{ V}$ ,  $T_A = 25^{\circ}\text{C}$ .

<sup>§</sup> Not more than one output should be shorted at a time.

NOTE 4:  $I_{CC}$  is measured with outputs open, A = B grounded, and all other inputs at 4.5 V.

switching characteristics,  $V_{CC} = 5 \text{ V}$ ,  $T_A = 25^{\circ}\text{C}$

PARAMETER <sup>†</sup>	FROM INPUT	TO OUTPUT	NUMBER OF GATE LEVELS	TEST CONDITIONS	MIN	TYP	MAX	UNIT
$t_{PLH}$	Any A or B data input	A < B, A > B	1	$C_L = 15 \text{ pF}$ , $R_L = 400 \Omega$ , See Note 5		7		ns
			2			12		
		3			17	26		
		4			23	35		
$t_{PHL}$	Any A or B data input	A < B, A > B	1			11		ns
			2			15		
		3			20	30		
		4			20	30		
$t_{PLH}$	A < B or A = B	A > B	1		7	11	ns	
$t_{PHL}$	A < B or A = B	A > B	1		11	17	ns	
$t_{PLH}$	A = B	A = B	2		13	20	ns	
$t_{PHL}$	A = B	A = B	2		11	17	ns	
$t_{PLH}$	A > B or A = B	A < B	1		7	11	ns	
$t_{PHL}$	A > B or A = B	A < B	1		11	17	ns	

<sup>†</sup>  $t_{PLH}$  = propagation delay time, low-to-high-level output

$t_{PHL}$  = propagation delay time, high-to-low-level output

NOTE 5: Load circuits and voltage waveforms are shown in Section 1.

**SN5485, SN54LS85, SN54S85**  
**SN7485, SN74LS85, SN74S85**  
**4-BIT MAGNITUDE COMPARATORS**  
SDLS123 – MARCH 1974 – REVISED MARCH 1988

**recommended operating conditions**

	SN54LS85			SN74LS85			UNIT
	MIN	NOM	MAX	MIN	NOM	MAX	
Supply voltage, $V_{CC}$	4.5	5	5.5	4.75	5	5.25	V
High-level output current, $I_{OH}$			-400			-400	$\mu$ A
Low-level output current, $I_{OL}$			4			8	mA
Operating free-air temperature, $T_A$	-55		125	0		70	$^{\circ}$ C

**electrical characteristics over recommended operating free-air temperature range (unless otherwise noted)**

PARAMETER		TEST CONDITIONS†	SN54LS85			SN74LS85			UNIT
			MIN	TYP‡	MAX	MIN	TYP‡	MAX	
$V_{IH}$	High-level input voltage		2			2			V
$V_{IL}$	Low-level input voltage				0.7			0.7	V
$V_{IK}$	Input clamp voltage	$V_{CC} = \text{MIN}, I_I = -18 \text{ mA}$			-1.5			-1.5	V
$V_{OH}$	High-level output voltage	$V_{CC} = \text{MIN}, V_{IH} = 2 \text{ V}, V_{IL} = V_{IL \text{ max}}, I_{OH} = -400 \mu\text{A}$	2.5	3.4		2.7	3.4		V
$V_{OL}$	Low-level output voltage	$V_{CC} = \text{MIN}, I_{OL} = 4 \text{ mA}$		0.25	0.4		0.25	0.4	V
		$V_{CC} = \text{MIN}, V_{IH} = 2 \text{ V}, V_{IL} = V_{IL \text{ max}}, I_{OL} = 8 \text{ mA}$					0.35	0.5	
$I_I$	Input current at maximum input voltage	A < B, A > B inputs			0.1			0.1	mA
		all other inputs	$V_{CC} = \text{MAX}, V_I = 7 \text{ V}$		0.3			0.3	
$I_{IH}$	High-level input current	A < B, A > B inputs			20			20	$\mu$ A
		all other inputs	$V_{CC} = \text{MAX}, V_I = 2.7 \text{ V}$		60			60	
$I_{IL}$	Low-level input current	A < B, A > B inputs			-0.4			-0.4	mA
		all other inputs	$V_{CC} = \text{MAX}, V_I = 0.4 \text{ V}$		-1.2			-1.2	
$I_{OS}$	Short-circuit output current§	$V_{CC} = \text{MAX}$	-20		-100	-20		-100	mA
$I_{CC}$	Supply current	$V_{CC} = \text{MAX},$ See Note 4		10.4	20		10.4	20	mA

† For conditions shown as MIN or MAX, use the appropriate value specified under recommended operating conditions.

‡ All typical values are at  $V_{CC} = 5 \text{ V}, T_A = 25^{\circ}\text{C}$ .

§ Not more than one output should be shorted at a time, and duration of the short-circuit should not exceed one second.

NOTE 4:  $I_{CC}$  is measured with outputs open, A = B grounded, and all other inputs at 4.5 V.

**switching characteristics,  $V_{CC} = 5 \text{ V}, T_A = 25^{\circ}\text{C}$**

PARAMETER¶	FROM INPUT	TO OUTPUT	NUMBER OF GATE LEVELS	TEST CONDITIONS	MIN	TYP	MAX	UNIT
$t_{PLH}$	Any A or B data input	A < B, A > B	1	$C_L = 15 \text{ pF}, R_L = 2 \text{ k}\Omega,$ See Note 5			14	ns
			2			19		
			3			24	36	
			4			27	45	
$t_{PHL}$	Any A or B data input	A < B, A > B	1				11	ns
			2			15		
			3			20	30	
			4			23	45	
$t_{PLH}$	A < B or A = B	A > B	1			14	22	ns
$t_{PHL}$	A < B or A = B	A > B	1			11	17	ns
$t_{PLH}$	A = B	A = B	2			13	20	ns
$t_{PHL}$	A = B	A = B	2			13	26	ns
$t_{PLH}$	A > B or A = B	A < B	1		14	22	ns	
$t_{PHL}$	A > B or A = B	A < B	1		11	17	ns	

¶  $t_{PLH}$  = propagation delay time, low-to-high-level output

$t_{PHL}$  = propagation delay time, high-to-low-level output

NOTE 5: Load circuits and voltage waveforms are shown in Section 1.

SN5485, SN54LS85, SN54S85  
 SN7485, SN74LS85, SN74S85  
 4-BIT MAGNITUDE COMPARATORS

SDLS123 – MARCH 1974 – REVISED MARCH 1988

recommended operating conditions

	SN54S85			SN74S85			UNIT
	MIN	NOM	MAX	MIN	NOM	MAX	
Supply voltage, $V_{CC}$	4.5	5	5.5	4.75	5	5.25	V
High-level output current, $I_{OH}$			-1			-1	mA
Low-level output current, $I_{OL}$			20			20	mA
Operating free-air temperature, $T_A$	-55		125	0		70	°C

electrical characteristics over recommended operating free-air temperature range (unless otherwise noted)

PARAMETER		TEST CONDITIONS†	MIN	TYP‡	MAX	UNIT
$V_{IH}$	High-level input voltage		2			V
$V_{IL}$	Low-level input voltage				0.8	V
$V_{IK}$	Input clamp voltage	$V_{CC} = \text{MIN}, I_I = -18 \text{ mA}$			-1.2	V
$V_{OH}$	High-level output voltage	$V_{CC} = \text{MIN}, V_{IH} = 2 \text{ V},$ $V_{IL} = 0.8 \text{ V}, I_{OH} = -1 \text{ mA}$	SN54S85 2.5	3.4		V
$V_{OL}$	Low-level output voltage	$V_{CC} = \text{MIN}, V_{IH} = 2 \text{ V},$ $V_{IL} = 0.8 \text{ V}, I_{OL} = 20 \text{ mA}$			0.5	V
$I_I$	Input current at maximum input voltage	$V_{CC} = \text{MAX}, V_I = 5.5 \text{ V}$			1	mA
$I_{IH}$	High-level input current	$V_{CC} = \text{MAX}, V_I = 2.7 \text{ V}$			50	$\mu\text{A}$
	A < B, A > B inputs all other inputs				150	
$I_{IL}$	Low-level input current	$V_{CC} = \text{MAX}, V_I = 0.5 \text{ V}$			-2	mA
	A < B, A > B inputs all other inputs				-6	
$I_{OS}$	Short-circuit output current §	$V_{CC} = \text{MAX}$	-40		-100	mA
$I_{CC}$	Supply current	$V_{CC} = \text{MAX}, \text{ See Note 4}$	73		115	mA
		$V_{CC} = \text{MAX}, T_A = 125^\circ\text{C},$ See Note 4				

† For conditions shown as MIN or MAX, use the appropriate value specified under recommended operating conditions.

‡ All typical values are at  $V_{CC} = 5 \text{ V}, T_A = 25^\circ\text{C}$ .

§ Not more than one output should be shorted at a time, and duration of the short-circuit should not exceed one second.

NOTE 4:  $I_{CC}$  is measured with outputs open, A = B grounded, and all other inputs at 4.5 V.

switching characteristics,  $V_{CC} = 5 \text{ V}, T_A = 25^\circ\text{C}$

PARAMETER¶	FROM INPUT	TO OUTPUT	NUMBER OF GATE LEVELS	TEST CONDITIONS	MIN	TYP	MAX	UNIT
$t_{PLH}$	Any A or B data input	A < B, A > B	1	$C_L = 15 \text{ pF},$ $R_L = 280 \Omega,$ See Note 5		5		ns
			2			7.5		
		3			10.5	16		
		4			12	18		
$t_{PHL}$	Any A or B data input	A < B, A > B	1			5.5		ns
			2			7		
		3			11	16.5		
		4			11	16.5		
$t_{PLH}$	A < B or A = B	A > B	1			5	7.5	ns
$t_{PHL}$	A < B or A = B	A > B	1			5.5	8.5	ns
$t_{PLH}$	A = B	A = B	2		7	10.5	ns	
$t_{PHL}$	A = B	A = B	2		5	7.5	ns	
$t_{PLH}$	A > B or A = B	A < B	1		5	7.5	ns	
$t_{PHL}$	A > B or A = B	A < B	1		5.5	8.5	ns	

¶  $t_{PLH}$  = propagation delay time, low-to-high-level output

$t_{PHL}$  = propagation delay time, high-to-low-level output

NOTE 5: Load circuits and voltage waveforms are shown in Section 1.

SN5485, SN54LS85, SN54S85  
 SN7485, SN74LS85, SN74S85  
**4-BIT MAGNITUDE COMPARATORS**

SDLS123 - MARCH 1974 - REVISED MARCH 1988

TYPICAL APPLICATION DATA

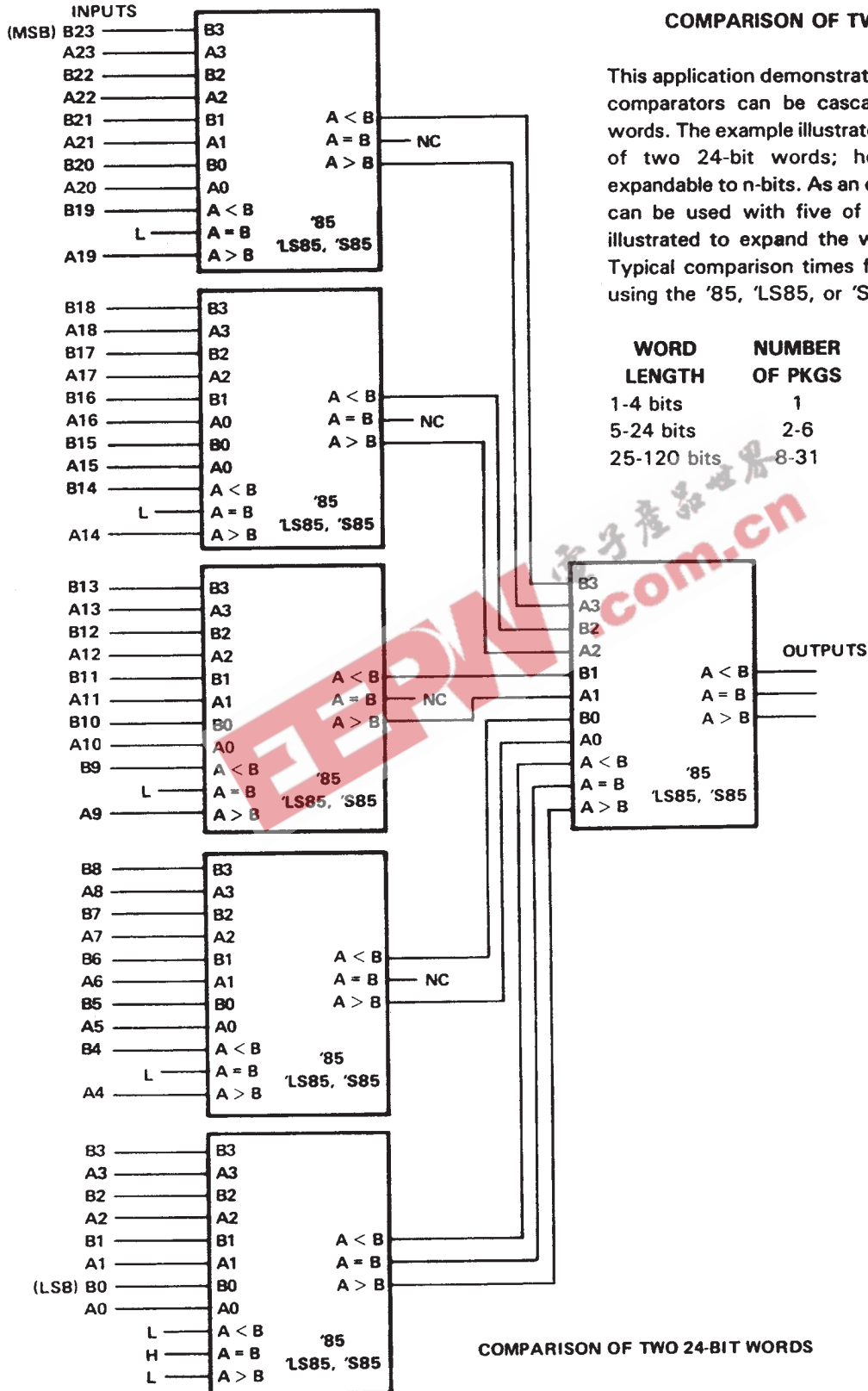

## IMPORTANT NOTICE

Texas Instruments and its subsidiaries (TI) reserve the right to make changes to their products or to discontinue any product or service without notice, and advise customers to obtain the latest version of relevant information to verify, before placing orders, that information being relied on is current and complete. All products are sold subject to the terms and conditions of sale supplied at the time of order acknowledgement, including those pertaining to warranty, patent infringement, and limitation of liability.

TI warrants performance of its semiconductor products to the specifications applicable at the time of sale in accordance with TI's standard warranty. Testing and other quality control techniques are utilized to the extent TI deems necessary to support this warranty. Specific testing of all parameters of each device is not necessarily performed, except those mandated by government requirements.

CERTAIN APPLICATIONS USING SEMICONDUCTOR PRODUCTS MAY INVOLVE POTENTIAL RISKS OF DEATH, PERSONAL INJURY, OR SEVERE PROPERTY OR ENVIRONMENTAL DAMAGE ("CRITICAL APPLICATIONS"). TI SEMICONDUCTOR PRODUCTS ARE NOT DESIGNED, AUTHORIZED, OR WARRANTED TO BE SUITABLE FOR USE IN LIFE-SUPPORT DEVICES OR SYSTEMS OR OTHER CRITICAL APPLICATIONS. INCLUSION OF TI PRODUCTS IN SUCH APPLICATIONS IS UNDERSTOOD TO BE FULLY AT THE CUSTOMER'S RISK.

In order to minimize risks associated with the customer's applications, adequate design and operating safeguards must be provided by the customer to minimize inherent or procedural hazards.

TI assumes no liability for applications assistance or customer product design. TI does not warrant or represent that any license, either express or implied, is granted under any patent right, copyright, mask work right, or other intellectual property right of TI covering or relating to any combination, machine, or process in which such semiconductor products or services might be or are used. TI's publication of information regarding any third party's products or services does not constitute TI's approval, warranty or endorsement thereof.