

CMOS 4-BIT MICROCONTROLLER

TMP47P800N  
TMP47P800F

The 47P800 is the OTP microcontroller with 64kbits EPROM. For program operation, the programming is achieved by using with EPROM programmer (TMM2764D type) and adapter socket (BM1108). The function of this device is exactly same as the 47C800.

PART No.	ROM	RAM	PACKAGE
TMP47P800N	OTP	512 x 4-bit	SDIP42
TMP47P800F	8192 x 8-bit		QFP44

PIN ASSIGNMENT (TOP VIEW)

SDIP42

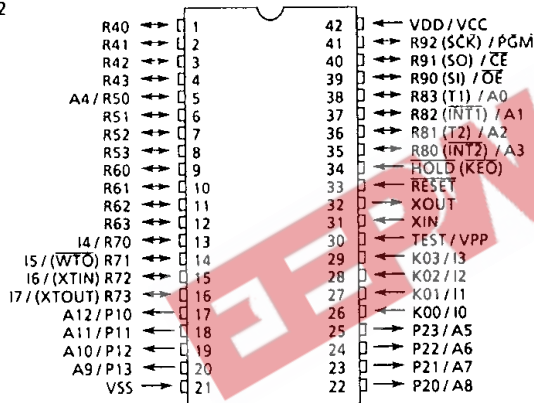

QFP44

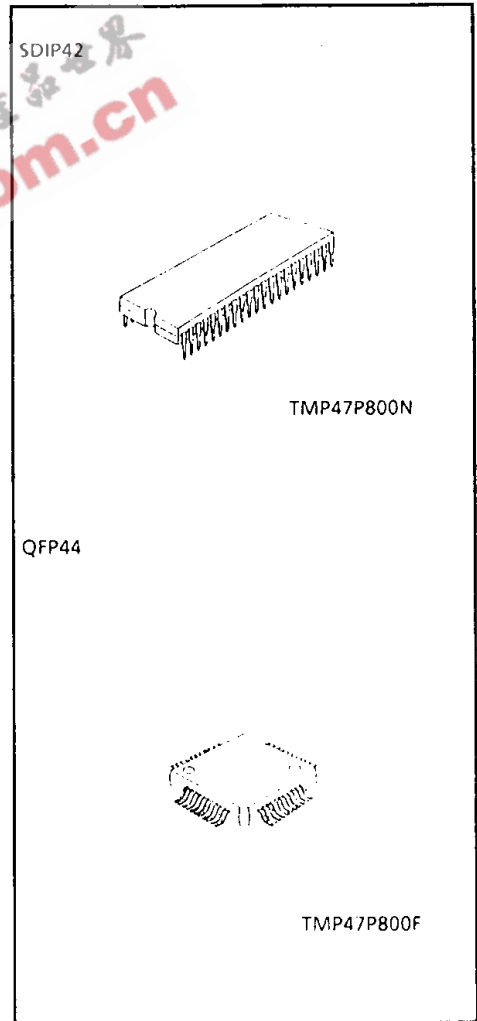
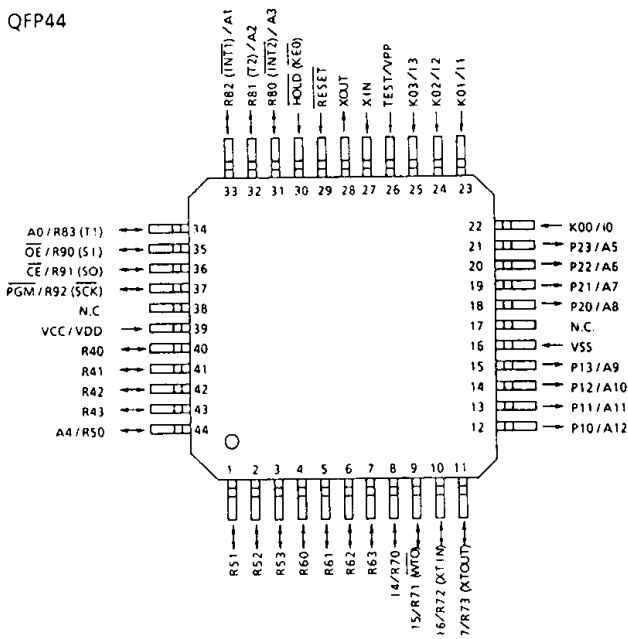

## PIN FUNCTION

The 47P800 has MCU mode and PROM mode.

## (1) MCU mode

The 47C800 and the 47P800 are pin compatible (TEST pin for out-going test. Be fixed to low level).

## (2) PROM mode

PIN NAME	Input/Output	FUNCTIONS	PIN NAME (MCU MODE)
A12 - A9	Input	Address inputs	P10 - P13
A8 - A5			P20 - P23
A4			R50
A3 - A0			R80 - R83
I7 - I4	I/O	Data inputs / outputs	R73 - R70
I3 - I0			K03 - K00
$\overline{\text{PGM}}$	Input	Program control input	R92
$\overline{\text{CE}}$		Chip Enable input	R91
OE		Output Enable input	R90
VPP	Power supply	+ 21V / 5V (Program supply voltage)	TEST
VCC		+ 5V	VDD
VSS		0V	VSS
R53 - R51	I/O	Be fixed to low level.	
R63 - R60			
R43 - R42			
R41 - R40			
$\overline{\text{RESET}}$	Input	PROM mode setting pins. Be fixed to low level.	
$\overline{\text{HOLD}}$	Input		
XIN	Input	Resonator connecting pins	
XOUT	Output		

**OPERATIONAL DESCRIPTION**

The following is an explanation of hardware configuration and operation in relation to the 47P800. The 47P800 is the same as the 47C800 except that an EPROM or OTP is used instead of a built-in Mask ROM.

**1. OPERATION MODE**

The 47P800 has an MCU mode and PROM mode.

**1.1 MCU mode**

The MCU mode is set by fixing the TEST / VPP pin at the "L" level. Operation in the MCU Mode in the same as for the 47C800 except that the TEST / VPP pin does not have pull-down resistor and can not be used open.

**1.1.1 Program memory**

The program storage area is the same as for the 47C800.

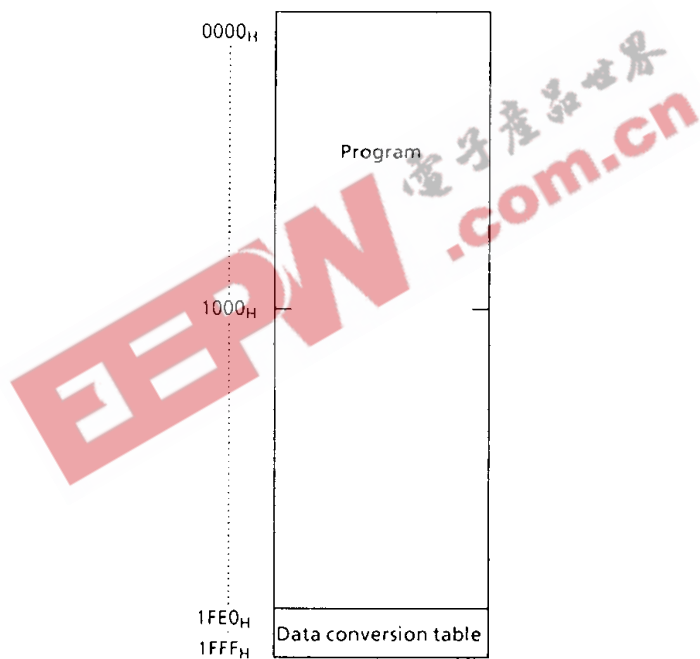

Figure 1-1. Program area

**1.1.2 Data memory**

The 47P800 has two built in 256X4 bits data memory banks (DMB0, DMB1).

1.1.3 Input /Output Circuitry

- (1) Control pins  
This is the same as for the 47C800 except that there is no pull-down resistor for the TEST pin.
- (2) I/O ports  
The input / output circuit of the 47C800 is the same as I/O code RA of the 47C800 external resistor, for example, is required when using as evaluator of other I/O codes (RB, RC) (Refer to Figure 1-2).



Figure 1-2. I/O code and external circuitry

1.2 PROM mode

The PROM mode is set by setting the  $\overline{\text{RESET}}$ ,  $\overline{\text{HOLD}}$ , K00 and K01 pins to the "L" level. The PROM mode can be used as a general-purpose PROM writer for program writing and verification (A high-speed program mode is used set the ROM type the same as for the TMM2764D).

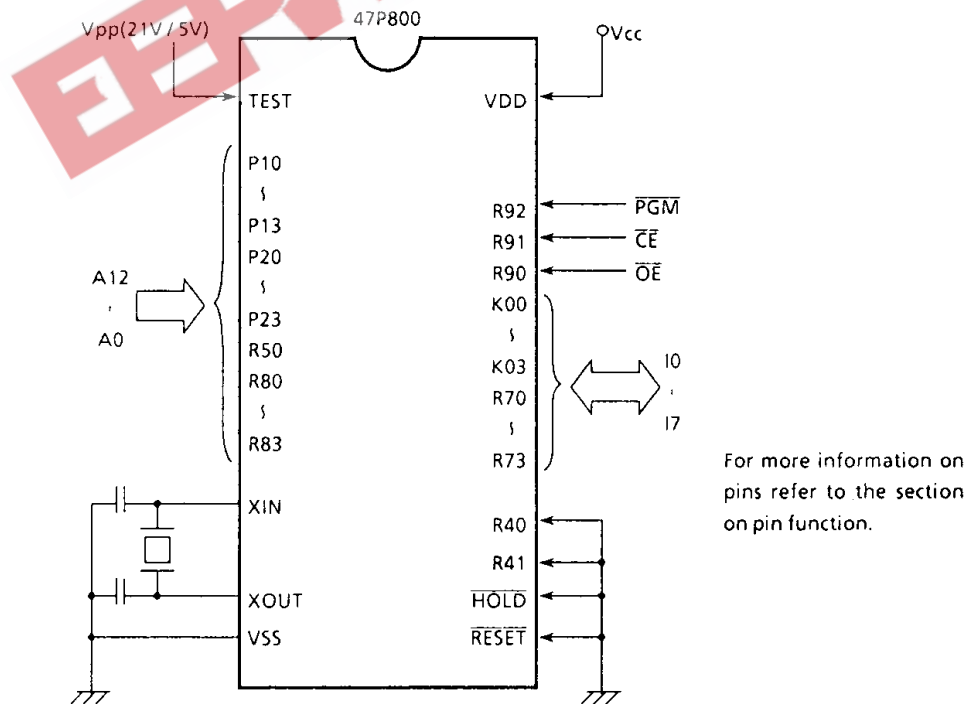

For more information on pins refer to the section on pin function.

Figure 1-3. Setting for PROM mode

An adapter socket is available for connecting a PROM writer.

- BM1108 : TMP47P800N
- BM1111 : TMP47P800F



## ELECTRICAL CHARACTERISTICS

ABSOLUTE MAXIMUM RATINGS (V<sub>SS</sub> = 0V)

PARAMETER	SYMBOL	PINS	RATING	UNIT
Supply Voltage	V <sub>DD</sub>		- 0.3 to 7	V
Program Voltage	V <sub>PP</sub>	TEST / VPP pin	- 0.3 to 22.0	V
Input Voltage	V <sub>IN</sub>		- 0.3 to V <sub>DD</sub> + 0.3	V
Output Voltage	V <sub>OUT1</sub>	R7,	- 0.3 to V <sub>DD</sub> + 0.3	V
	V <sub>OUT2</sub>	Ports P1, P2, R4, R5, R6, R8, R9	- 0.3 to 10	
Output (per 1 pin)	I <sub>OUT2</sub>	Port R	3.2	mA
Output Current (total)	ΣI <sub>OUT1</sub>	Ports P1, P2	120	mA
Power Dissipation	PD		600	mW
Soldering Temperature (time)	T <sub>sid</sub>		260 (10sec)	°C
Storage Temperature	T <sub>stg</sub>		- 55 to 125	°C
Operating Temperature	T <sub>opr</sub>		- 40 to 70	°C

RECOMMENDED OPERATING CONDITIONS (V<sub>SS</sub> = 0V, T<sub>opr</sub> = - 40 to 70°C)

PARAMETER	SYMBOL	PINS	CONDITIONS	Min.	Max.	UNIT
Supply Voltage	V <sub>DD</sub>		In the Normal mode	4.5	6.0	V
			In the SLOW mode			
			In the HOLD mode	2.0		
Input High Voltage	V <sub>IH1</sub>	Except Hysteresis Input	V <sub>DD</sub> ≥ 4.5V	V <sub>DD</sub> × 0.7	V <sub>DD</sub>	V
	V <sub>IH2</sub>	Hysteresis Input		V <sub>DD</sub> × 0.75		
	V <sub>IH3</sub>		V <sub>DD</sub> < 4.5V	V <sub>DD</sub> × 0.9		
Input Low Voltage	V <sub>IL1</sub>	Hysteresis Input	V <sub>DD</sub> ≥ 4.5V	0	V <sub>DD</sub> × 0.3	V
	V <sub>IL2</sub>	Hysteresis Input			V <sub>DD</sub> × 0.25	
	V <sub>IL3</sub>		V <sub>DD</sub> < 4.5V		V <sub>DD</sub> × 0.1	
Clock Frequency	f <sub>c</sub>	XIN, XOUT		0.4	6.0	MHz
	f <sub>s</sub>	XTIN, XTOUT		30	34	KHz

Note. Input Voltage V<sub>IH3</sub>, V<sub>IL3</sub>: in the SLOW operation or HOLD operation.

D.C. CHARACTERISTICS	( $V_{SS} = 0V$ , $T_{opr} = -40$ to $70^{\circ}C$ )
----------------------	--

PARAMETER	SYMBOL	PINS	CONDITIONS	Min.	Typ.	Max.	UNIT
Hysteresis Voltage	$V_{HS}$	Hysteresis input		—	0.7	—	V
Input Current	$I_{IN1}$	Port K0, TEST, RESET, HOLD	$V_{DD} = 5.5V$	—	—	$\pm 2$	$\mu A$
	$I_{IN2}$	Ports R (open-drain)	$V_{IN} = 5.5V / 0V$				
Input Resistance	$R_{IN2}$	RESET		100	220	450	$K\Omega$
Output Leakage Current	$I_{LO}$	Ports R (open drain)	$V_{DD} = 5.5V$ , $V_{OUT} = 5.5V$	—	—	2	$\mu A$
Output Low Voltage	$V_{OL2}$	Except XOUT XTOUT, Ports P	$V_{DD} = 4.5V$ , $I_{OL} = 1.6mA$	—	—	0.4	V
Low Level Output Current	$I_{OL1}$	Ports P1, P2	$V_{DD} = 4.5V$ , $V_{OL} = 1.0V$	—	20	—	mA
Supply Current (in the Nomal mode)	$I_{DD}$		$V_{DD} = 5.5V$ , $f_C = 4MHz$	—	5	10	mA
Supply Current (in the SLOW mode)	$I_{DSS}$		$V_{DD} = 5.0V$ , $f_S = 32.768KHz$	—	5	8	mA
Supply Current (in the HOLD mode)	$I_{DDH}$		$V_{DD} = 5.5V$	—	0.5	10	$\mu A$

Note 1. Typ. values show those at  $T_{opr} = 25^{\circ}C$ ,  $V_{DD} = 5V$ .

Note 2. Input Current  $I_{IN1}$ ; The current through resistor is not included, when the input resistor (pull-up/pull-down) is contained.

Note 3. Supply Current  $I_{DD}$ ,  $I_{DDH}$ ;  $V_{IN} = 5.3V/0.2V$

The K0 port is opened when the input resistor is contained. The voltage applied to the R port is within the valid range.

Note 4. Supply Current  $I_{DSS}$ ;  $V_{IN} = 2.8V/0.2V$ , low frequency clock is only oscillated (connecting XTIN, XTOUT).

**A.C. CHARACTERISTICS** ( $V_{SS} = 0V, V_{DD} = 4.5 \text{ to } 6.0V, T_{opr} = -40 \text{ to } 70^\circ\text{C}$ )

PARAMETER	SYMBOL	CONDITION	Min.	Typ.	Max.	UNIT
Instruction Cycle Time	$t_{cy}$	in the Normal mode	1.33	–	20	$\mu\text{s}$
		in the SLOW mode	235	–	267	
High level Clock Pulse Width	$t_{WCH}$	For external clock operation	80	–	–	ns
Low level Clock Pulse Width	$t_{WCL}$					
Shift Data Hold Time	$t_{SDH}$		$0.5t_{cy} - 300$	–	–	ns

Note. Shift Data Hold Time:

External circuit for  $\overline{\text{SCK}}$  pin and SO pin

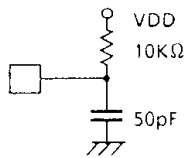

Serial port (completion of transmission)



**RECOMMENDED OSCILLATING CONDITIONS** ( $V_{SS} = 0V, V_{DD} = 4.5 \text{ to } 6.0V, T_{opr} = -40 \text{ to } 70^\circ\text{C}$ )

Recommended oscillating conditions of the 47P800 are equal to the 47C800's.

**D.C. / A.C. CHARACTERISTICS (PROM mode)** ( $V_{SS} = 0V$ )

(1) Read Operation

PARAMETER	SYMBOL	CONDITION	Min.	Typ.	Max.	UNIT
Output Level High Voltage	$V_{IH4}$		$V_{CC} \times 0.7$	–	$V_{CC}$	V
Output Level Low Voltage	$V_{IL4}$		0	–	$V_{CC} \times 0.1$	V
Supply Voltage	$V_{CC}$		4.75	–	6.0	V
Programming Voltage	$V_{PP}$					
Address Access Time	$t_{ACC}$	$V_{CC} = 5.0 \pm 0.25V$	0	–	350	ns



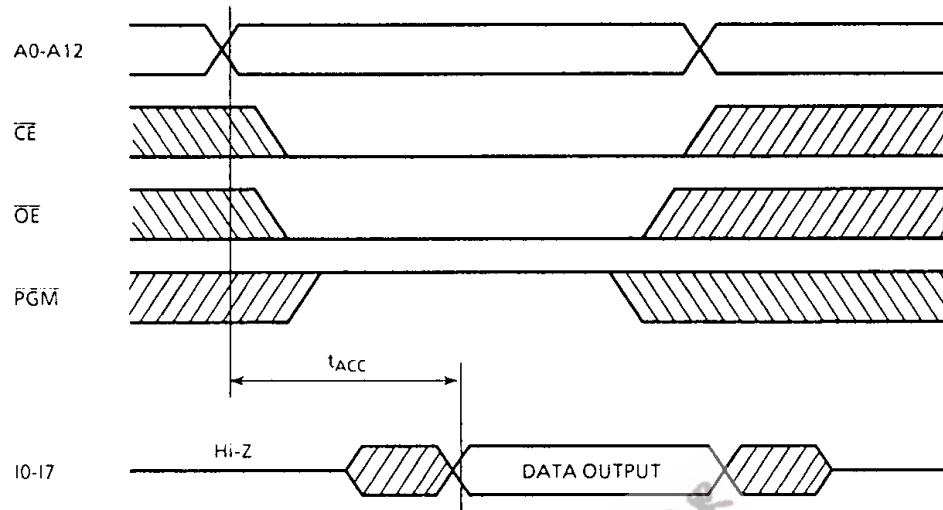

(2) High Speed Programming Operation

PARAMETER	SYMBOL	CONDITION	Min.	Typ.	Max.	UNIT
Input High Voltage	$V_{IH4}$		$V_{CC} \times 0.7$	-	$V_{CC}$	V
Input Low Voltage	$V_{IL4}$		0	-	$V_{CC} \times 0.1$	V
Supply Voltage	$V_{CC}$		4.75	-	6.0	V
$V_{PP}$ Power Supply Voltage	$V_{PP}$		20.5	21.0	21.5	V
Programming Pulse Width	$t_{PW}$	$V_{CC} = 6.0 \pm 0.25V$	0.95	1.0	1.05	ms

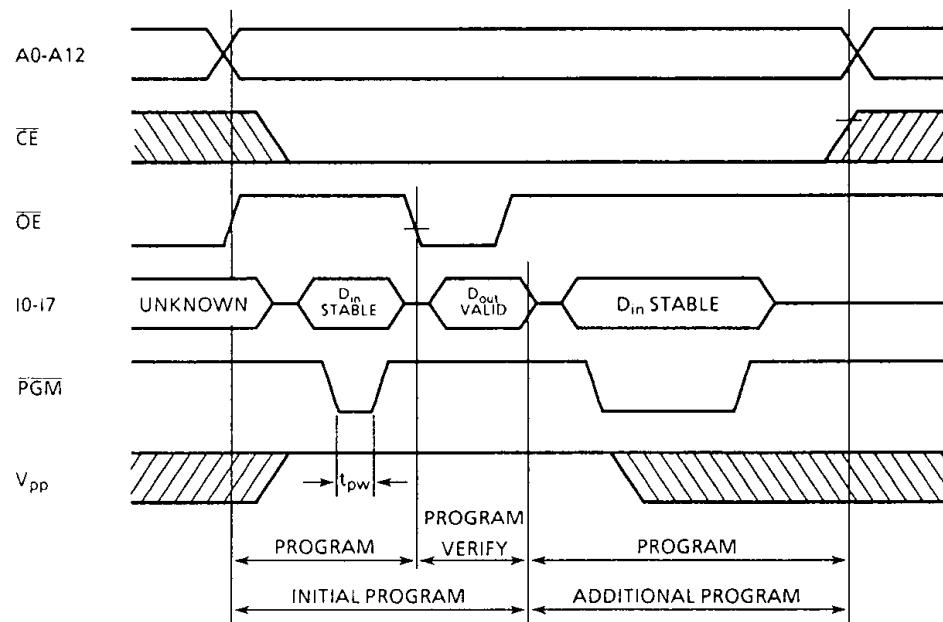

※ Difference compared with the 47C800  
 The 47P800 is different from the 47C800 with respect to the following spec points.

PARAMETER	SYMBOL	CONDITION	47C800			47P800			UNIT
			Min.	Typ.	Max.	Min.	Typ.	Max.	
Supply Voltage	$V_{DD}$	in the NORMAL operation	4.5	—	6.0	4.5	—	6.0	V
		in the SLOW operation	2.7	—					
Supply Current	$I_{DD}$	in the NORMAL operation	—	3	6	—	5	10	mA
	$I_{DDs}$	in the SLOW operation	—	30 $\mu$ A ( $V_{DD} = 3V$ )	T.B.D	—	5mA ( $V_{DD} = 5V$ )	8mA ( $V_{DD} = 5V$ )	—

Note. Be fixed low level at MCU mode because of TEST pin does not have pull-down resistor.

TYPICAL CHARACTERISTICS

