

# W541E/C480 DATA SHEET



**4BIT MICROCONTROLLER, 4K ×16 ROM, 256 ×4 RAM 128 -DOT LCD**

## **Table of Contents-**

1.	INTRODUCTION.....	2
2.	FEATURES .....	3
3.	ARCHITECTURE .....	5
3.1	BLOCK DIAGRAM.....	5
3.2	PIN CONFIGURATION.....	6
3.3	PAD DESCRIPTION.....	7
4.	ABSOLUTE MAXIMUM RATINGS .....	8
5.	DC CHARACTERISTICS.....	9
6.	AC CHARACTERISTICS.....	10
7.	TYPICAL APPLICATION CIRCUIT.....	11
8.	PACKAGE DIMENSION .....	12
9.	VERSION HISTORY .....	13

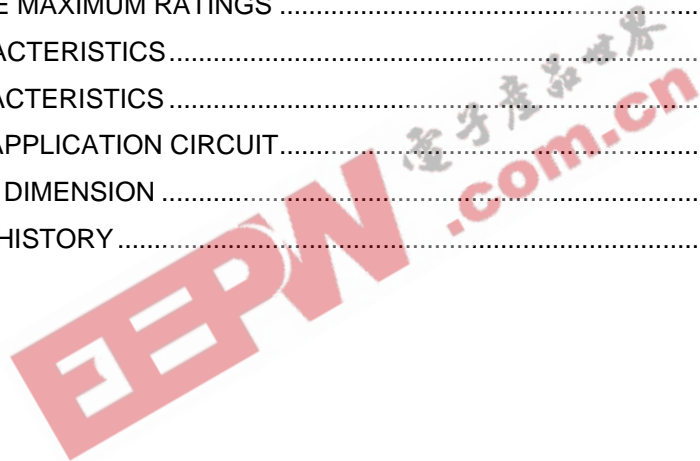

# W541E/C480 DATA SHEET



## 1. INTRODUCTION

The W541E480 and W541C480 are high-performance 4-bit microcontroller ( $\mu\text{C}$ ) with an LCD driver and the flash EEPROM and mask ROM for the program memory. The device contains a 4-bit ALU, two 8-bit timers, two dividers, a  $32 \times 4$  LCD driver, and five 4-bit I/O ports (including 1 output port to drive the LEDs). There are also five interrupt sources and 8-level subroutine nesting for interrupt applications. The W541E480 and W541C480 have two power reduction modes, hold mode and stop mode, which help to minimize power dissipation.

The W541E480 and W541C480 have two oscillator circuits and can work in dual-clock or single-clock operation mode. It is suitable for remote controllers, watches and clocks, speech synthesis LSI controllers, hand-held games and other products.



# W541E/C480 DATA SHEET



## 2. FEATURES

- Operating voltage: 2.4V to 5.5V (LCD drive voltage: 3.0V, or 4.5V)
- Operating frequency up to 4 MHz
- Crystal/RC oscillation circuit selectable by code option for system clock
- Memory
  - 4096 × 16 bit program ROM (including 4K × 4 bit look-up table)
  - 256 × 4 bit data RAM (including 16 working registers)
  - 32 × 4 LCD data RAM
- Single or Dual Clock Mode
  - Single (main oscillator only) or dual clock (both main and sub-oscillator) by mask option .
  - Dual-clock slow operation mode: system is operated by the sub-oscillator (FOSC = Fs and Fm is stopped)
  - Sub-oscillator is only 32.768 KHz crystal for dual clock mode.
  - Main oscillator is crystal or RC oscillation by mask code option .
  - Main clock : High-frequency clock (400 KHz to 4 MHz) or low-frequency clock (32.768 KHz) is selected by mask code option.
- 21 input/output pins
  - Ports for input only: 2 ports/8 pins
  - Input/output ports: 2 ports/8 pins
  - Port for output only: 1 port /4 pins (high sink current to drive LEDs)
  - MFP output pin: 1 pin (MFP)
- Power-down mode
  - Hold function: no operation (except for oscillator)
  - Stop function: no operation
- Five types of interrupts
  - Four internal interrupts (Divider 0, Divider 1, Timer 0, Timer 1)
  - One external interrupt (Port RC)
- LCD driver output
  - 32 segment × 4 common
  - Static, 1/2 duty (1/2 bias), 1/3 duty (1/2 or 1/3 bias), 1/4 duty (1/3 bias) driving mode can be selected
  - LCD driver output pins can be used as DC output ports; selectable by code option
- MFP output pin
  - Output is software selectable as modulating or nonmodulating frequency
  - Works as frequency output specified by Timer 1
- Two built-in 14-bit clock frequency divider circuit (divider 0 and divider 1)

## W541E/C480 DATA SHEET



- Two built-in 8-bit programmable countdown timers
  - Timer 0: one of two internal clock frequencies (FOSC/4 or FOSC/1024) can be selected
  - Timer 1: includes an auto-reload function; and one of three internal clock frequencies (FOSC or FOSC/64, Fs) can be selected or falling edge of pin RC.0 can be selected (output through MFP pin)
- Built-in 18/14-bit watchdog timer selectable for system reset
- Powerful instruction set: 125 instructions
- 8-level subroutine (include interrupt) nesting
- Up to 1  $\mu$ S instruction cycle (with 4 MHz operating frequency)
- Packaged in 80-pin QFP

EEPW 电子产品世界  
.com.cn

# W541E/C480 DATA SHEET



## 3. ARCHITECTURE

### 3.1 BLOCK DIAGRAM

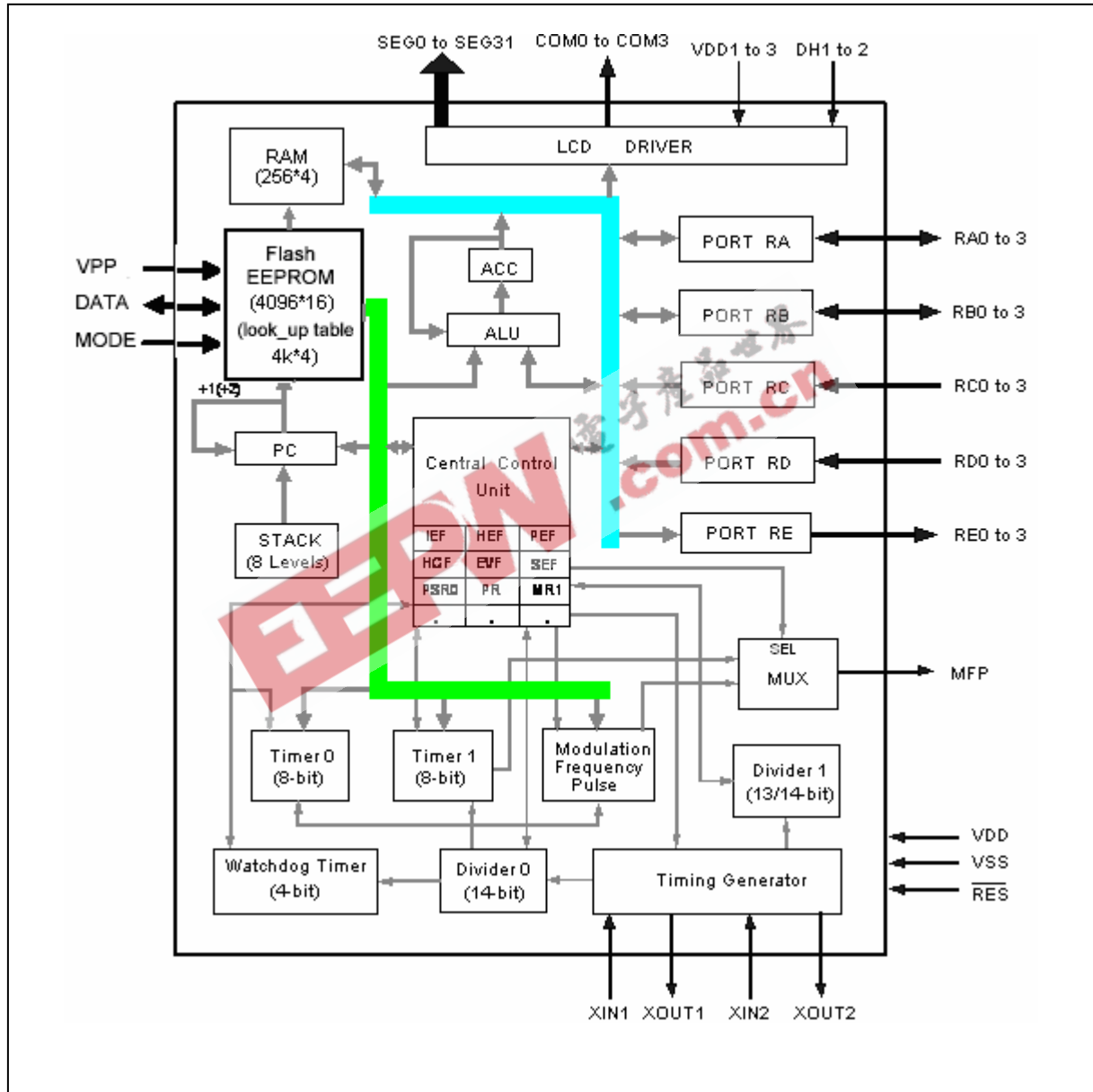

# W541E/C480 DATA SHEET



## 3.2 PIN CONFIGURATION

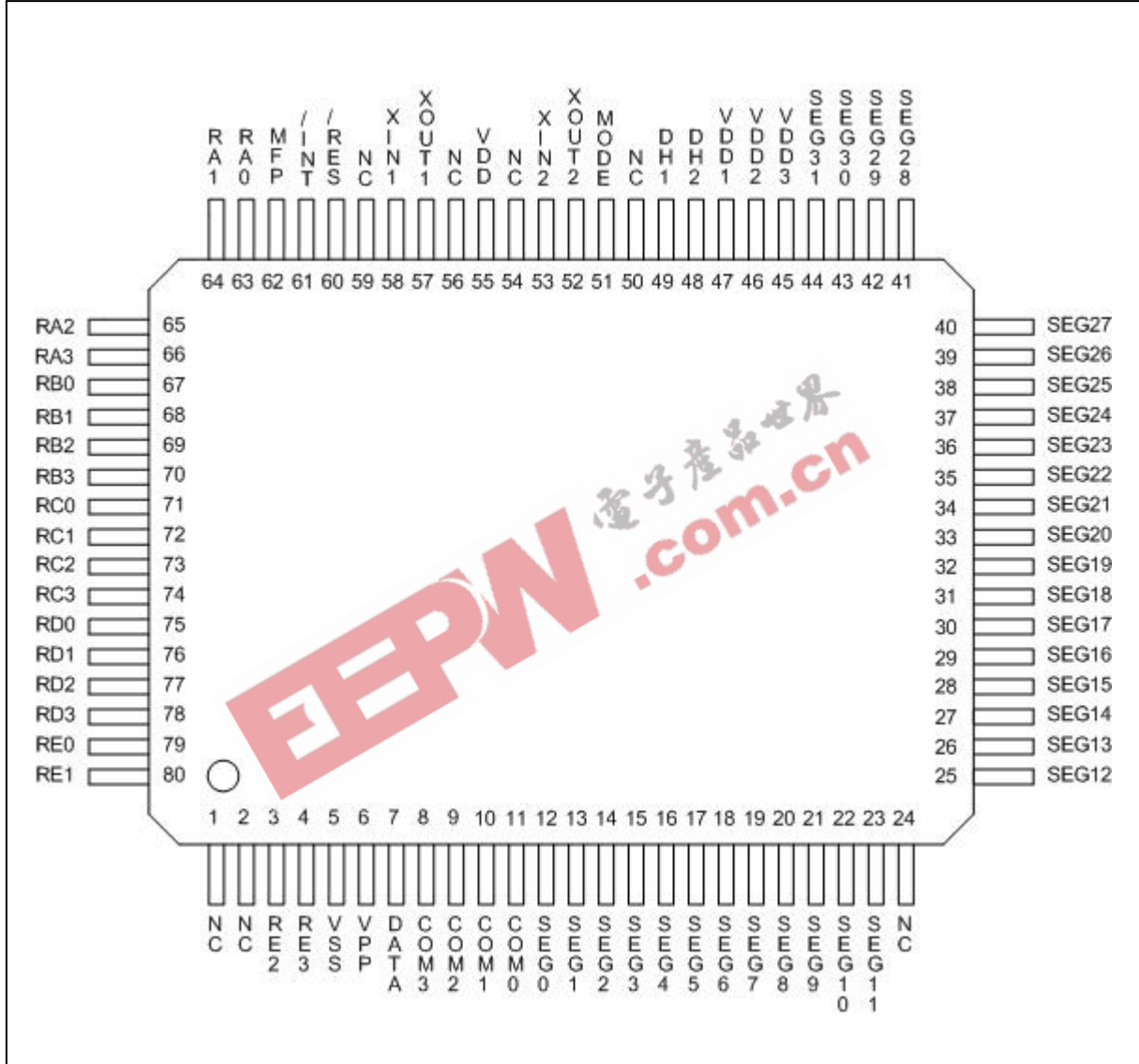

# W541E/C480 DATA SHEET



## 3.3 PAD DESCRIPTION

SYMBOL	I/O	FUNCTION																									
XIN1	I	Input pin for oscillator. Connected to crystal or resistor to generate system clock by code option. External 15~20pF capacitor uses to get accurate freq in crystal mode.																									
XOUT1	O	Output pin for oscillator Connected to crystal or resistor to generate system clock by code option. 20PF capacitor is built in internal for crystal mode.																									
XIN2	I	Input pin for sub-oscillator. Connected to a 32.768 KHz crystal. External 15~20pF capacitor uses to get accurate freq in crystal mode..																									
XOUT2	O	oscillator. Connected Output pin for sub to a 32.768 KHz crystal. 20PF capacitor is built in internal for crystal mode.																									
RA0 –RA3	I/O	Input/Output port. Input/output mode specified by port mode 1 register (PM1).																									
RB0 –RB3	I/O	Input/Output port. Input/output mode specified by port mode 2 register (PM2).																									
RC0 –RC3	I	4-bit port for input only. Each pin has an independent interrupt capability.																									
RD0 –RD3	I	4-bit port for input only.																									
RE0 –RE3	O	Output port only. This port provides high sink current to drive LEDs.																									
/INT	I	External interrupt pin with pull-high resistor. This pin is bonding option for the W541C250 body. Only for W541E480.																									
MFP	O	Output pin only. This pin can output modulating or nonmodulating frequency, or Timer 1 clock output specified by mode register 1 (MR1).																									
RES	I	System reset pin with pull-high resistor.																									
SEG0–SEG31	O	LCD segment output pins. Can also be used as DC output ports specified by code option.																									
COM0–COM3	O	LCD common signal output pins. <table border="1" style="margin-left: 20px;"> <thead> <tr> <th></th> <th>Static</th> <th>1/2 Duty</th> <th>1/3 Duty</th> <th>1/4 Duty</th> </tr> </thead> <tbody> <tr> <td>COM0</td> <td>Used</td> <td>Used</td> <td>Used</td> <td>Used</td> </tr> <tr> <td>COM1</td> <td>Not Used</td> <td>Used</td> <td>Used</td> <td>Used</td> </tr> <tr> <td>COM2</td> <td>Not Used</td> <td>Not Used</td> <td>Used</td> <td>Used</td> </tr> <tr> <td>COM3</td> <td>Not Used</td> <td>Not Used</td> <td>Not Used</td> <td>Used</td> </tr> </tbody> </table> <p>The LCD alternating frequency can be selected by code option.</p>		Static	1/2 Duty	1/3 Duty	1/4 Duty	COM0	Used	Used	Used	Used	COM1	Not Used	Used	Used	Used	COM2	Not Used	Not Used	Used	Used	COM3	Not Used	Not Used	Not Used	Used
	Static	1/2 Duty	1/3 Duty	1/4 Duty																							
COM0	Used	Used	Used	Used																							
COM1	Not Used	Used	Used	Used																							
COM2	Not Used	Not Used	Used	Used																							
COM3	Not Used	Not Used	Not Used	Used																							
DH1, DH2	I	Connection terminals for voltage doubler (halver) capacitor.																									

# W541E/C480 DATA SHEET



PAD DESCRIPTION, continued

SYMBOL	I/O	FUNCTION
VDD1, VDD2, VDD3	I	Positive (+) supply voltage terminal. Refer to Functional Description.
VDD	I	Positive power supply (+).
VSS	I	Negative power supply (-).
VPP	I	Voltage control pin for the flash EEPROM programming, erasing and verifying. This pin has a built-in pull-low resistor. Only for W541E480.
MODE	I	Mode selection pin for the flash EEPROM programming, erasing and verifying. This pin has a built-in pull-low resistor. Only for W541E480.
DATA	I/O	Data I/O pin for the flash EEPROM programming and verifying. This pin has a built-in pull-low resistor. Only for W541E480.

## 4. ABSOLUTE MAXIMUM RATINGS

PARAMETER	RATING	UNIT
Supply Voltage to Ground Potential	-0.3 to +7.0	V
Applied Input/Output Voltage	-0.3 to +7.0	V
Power Dissipation	120	mW
Ambient Operating Temperature	0 to +70	°C
Storage Temperature	-55 to +150	°C

**Note:** Exposure to conditions beyond those listed under Absolute Maximum Ratings may adversely affect the life and reliability of the device.



# W541E/C480 DATA SHEET



## 5. DC CHARACTERISTICS

(V<sub>DD</sub>-V<sub>SS</sub> = 3.0V, F<sub>m</sub> = 4 MHz, F<sub>s</sub> = 32.768 KHz, T<sub>A</sub> = 25° C, LCD on, no load; unless otherwise specified)

PARAMETER	SYM.	CONDITIONS		MIN.	TYP.	MAX.	UNIT
Operation current	IOP	Normal operation	Crystal mode	-	0.3	0.6	mA
			RC mode	-	1	2	
		Slow operation	-	3.5	8.0	μA	
Hold current	IHM	Normal operation	Crystal mode	-	135	270	μA
			RC mode	-	500	600	
		Slow operation	-	2.0	4.0		
Stop current	ISM	Stop mode		-	0.1	1	μA

(V<sub>DD</sub>-V<sub>SS</sub> = 3.0V, F<sub>m</sub> = 4 MHz, F<sub>s</sub> = 32.768 KHz, T<sub>A</sub> = 25° C, LCD on, Crystal mode, no load; unless otherwise specified)

PARAMETER	SYM.	CONDITIONS	MIN.	TYP.	MAX.	UNIT
Op. Voltage	V <sub>DD</sub>	-	2.4	-	5.5	V
Input Low Voltage	V <sub>IL</sub>	-	V <sub>SS</sub>	-	0.3 V <sub>DD</sub>	V
Input High Voltage	V <sub>IH</sub>	-	0.7 V <sub>DD</sub>	-	V <sub>DD</sub>	V
MFP Output Low Voltage	V <sub>ML</sub>	I <sub>OL</sub> = 6.0 mA	-	-	0.4	V
MFP Output High Voltage	V <sub>MH</sub>	I <sub>OH</sub> = 6.0 mA	2.4	-	-	V
Port RA, RB Output Low Voltage	V <sub>ABL</sub>	I <sub>OL</sub> = 6.0 mA	-	-	0.4	V
Port RA, RB Output High Voltage	V <sub>ABH</sub>	I <sub>OH</sub> = 3.0 mA	2.4	-	-	V
LCD Supply Current	I <sub>LCD</sub>	All Seg. ON	-	-	6	μA
SEG0-SEG31 Sink Current (Used as LCD Output)	I <sub>OL1</sub>	V <sub>OL</sub> = 0.4V V <sub>LCD</sub> = 0.0V	90	-	-	μA
SEG0-SEG31 Drive Current (Used as LCD Output)	I <sub>OH1</sub>	V <sub>OH</sub> = 2.4V V <sub>LCD</sub> = 3.0V	90	-	-	μA
Segment Sink Current (Used as DC Output)	I <sub>SL</sub>	V <sub>OL</sub> = 0.4V V <sub>LCD</sub> = 0.0V	-	4.0	-	mA
Segment Drive Current (Used as DC Output)	I <sub>SH</sub>	V <sub>OH</sub> = 2.4V V <sub>LCD</sub> = 3.0V	-	1.5	-	mA
Port RE Sink Current	I <sub>EL</sub>	V <sub>OL</sub> = 0.9V	9	13.5	-	mA
Port RE Source Current	I <sub>EH</sub>	V <sub>OH</sub> = 2.4V	1.5	3.0	-	mA
Port RA/RB Sink Current	I <sub>ABL</sub>	V <sub>OL</sub> = 0.4V	3	6	-	mA
Port RA/RB Source Current	I <sub>ABH</sub>	V <sub>OH</sub> = 2.4V	1.5	3.0	-	mA

# W541E/C480 DATA SHEET



DC Characteristics, continue

PARAMETER	SYM.	CONDITIONS	MIN.	TYP.	MAX.	UNIT
Port MFP Sink current	IML	VOL = 0.4V	3	6	-	mA
Port MFP Source current	IML	VOL = 2.4V	3	6	-	mA
Input Port Pull-up Resistor	RCD	Port RC, RD	100	350	600	KΩ
$\overline{\text{RES}}$ Pull-up Resistor	RRES	-	100	150	200	KΩ
$\overline{\text{INT}}$ Pull-up Resistor	RINT	-	100	150	200	KΩ
VPP Pull-down Resistor	RVPP	VDD = 5V	0.5	1	1.5	MΩ
MODE Pull-down Resistor	R <sub>MOD E</sub>	VDD = 5V	0.5	1	1.5	MΩ
DATA Pull-down Resistor	R <sub>DATA</sub>	VDD = 5V	50	100	150	KΩ

## 6. AC CHARACTERISTICS

(VDD-VSS = 3.0V, TA = 25° C, unless otherwise specified)

PARAMETER	SYM.	CONDITIONS	MIN.	TYP.	MAX.	UNIT
Op. Frequency	FOSC	RC type	-	-	4000	KHz
		Crystal type 1 (Option low speed type)	-	32.768	-	
		Crystal type 2 (Option high speed type)	400	-	4000	
Frequency Deviation by Voltage Drop for RC Oscillator	$\frac{\Delta f}{f}$	$\frac{f(3V) - f(2.4V)}{f(3V)}$	-	-	25	%
Instruction Cycle Time	Ti	One machine cycle	-	4/FOSC	-	S
Reset Active Width	TRAW1	FOSC = 32.768 KHz	1	-	-	μS
Interrupt Active Width	TIAW	FOSC = 32.768 KHz	1	-	-	μS

# W541E/C480 DATA SHEET



## 7. TYPICAL APPLICATION CIRCUIT

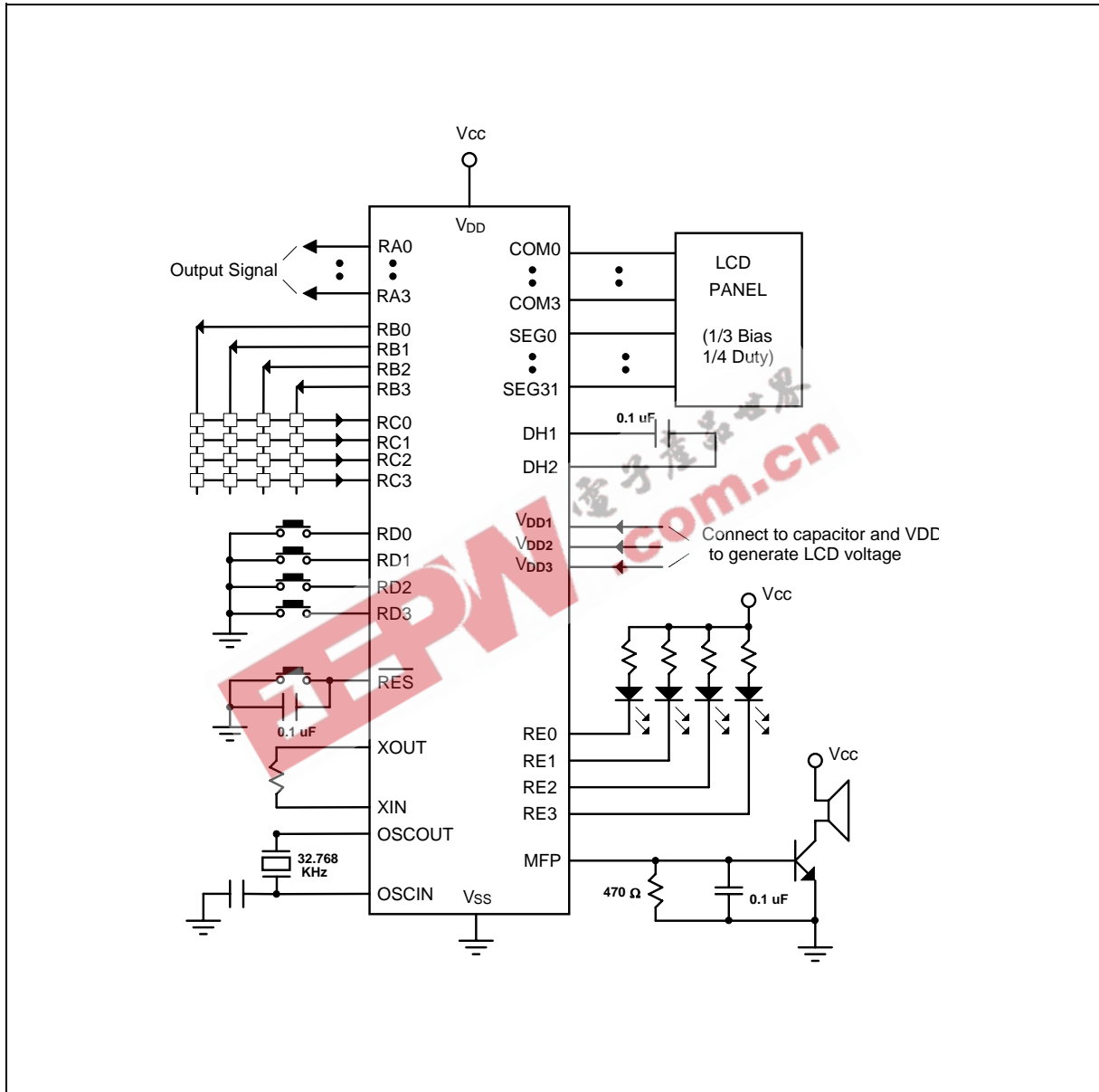

# W541E/C480 DATA SHEET



## 8. PACKAGE DIMENSION

### 80-Lead QFP

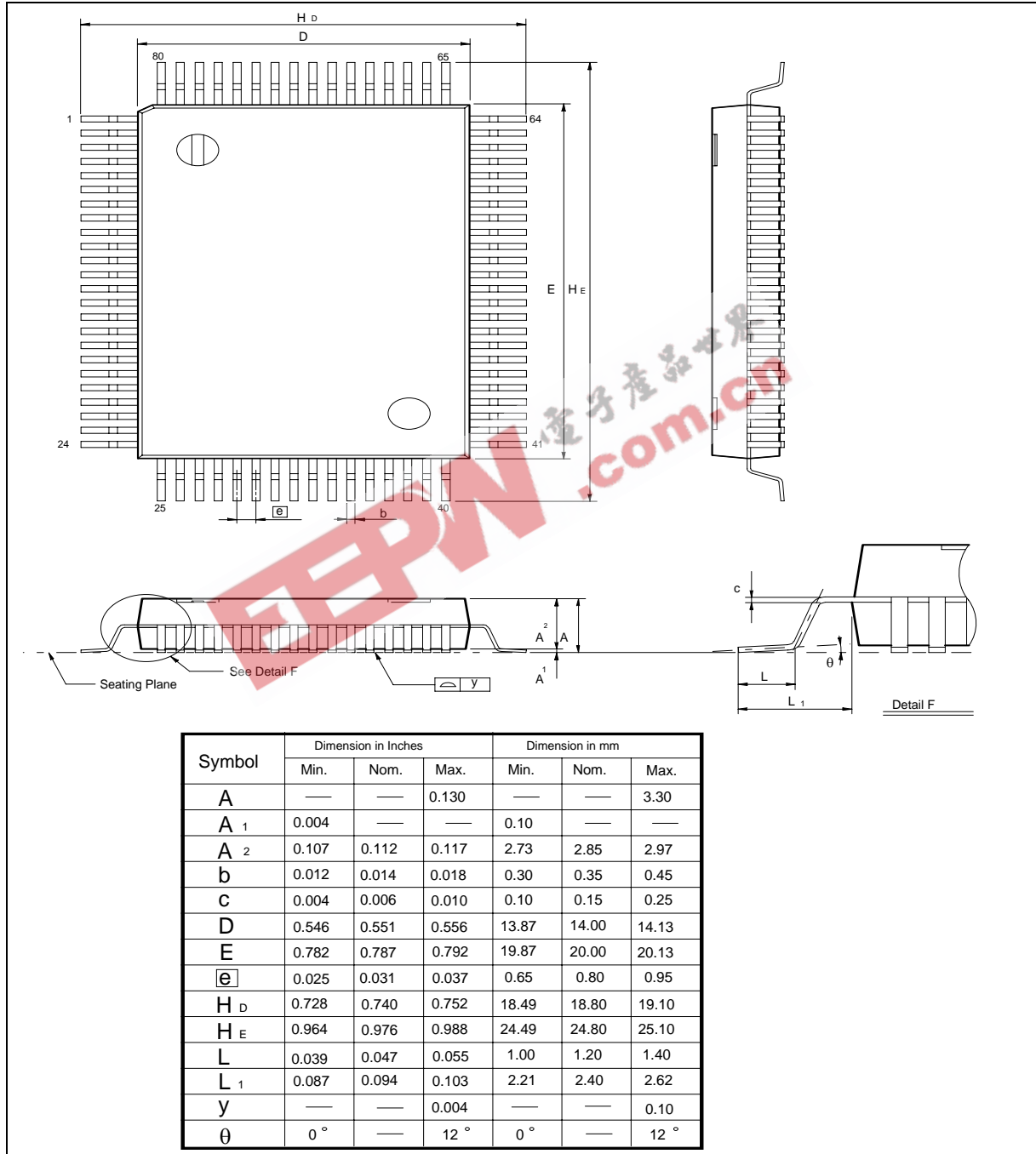

## W541E/C480 DATA SHEET



### 9. VERSION HISTORY

VERSION	DATE	PAGE	DESCRIPTION
A1	September, 2006	-	Formal Release
A2	June 8, 2007	-	Update DC & AC data

### Important Notice

Winbond products are not designed, intended, authorized or warranted for use as components in systems or equipment intended for surgical implantation, atomic energy control instruments, airplane or spaceship instruments, transportation instruments, traffic signal instruments, combustion control instruments, or for other applications intended to support or sustain life. Further more, Winbond products are not intended for applications wherein failure of Winbond products could result or lead to a situation wherein personal injury, death or severe property or environmental damage could occur.

Winbond customers using or selling these products for use in such applications do so at their own risk and agree to fully indemnify Winbond for any damages resulting from such improper use or sales.

---

Please note that all data and specifications are subject to change without notice.  
All the trademarks of products and companies mentioned in this datasheet belong to their respective owners.