

4-bit dual supply bus buffer level translator with a side series resistor

Features

- High speed: $t_{PD} = 4.3\text{ns}$ (Max.) at $T_A = 85^\circ\text{C}$
 $V_{CCB} = 1.65\text{V}$; $V_{CCA} = 3.0\text{V}$
- Low power dissipation:
 $I_{CCA} = I_{CCB} = 5\mu\text{A}$ (Max.) at $T_A=85^\circ\text{C}$
- Symmetrical output impedance:
 $|I_{OHA}| = I_{OLA} = 10\text{mA}$ Min at
 $V_{CCA} = 2.75\text{V}$; $V_{CCB} = 1.4\text{V}$ to 3.6V
 $|I_{OHB}| = I_{OLB} = 4\text{mA}$ Min at
 $V_{CCB} = 1.65\text{V}$; $V_{CCA} = 1.4$ to 3.6V)
- Balanced propagation delays:
 $t_{PLH} \cong t_{PHL}$
- Power down protection on inputs and outputs
- 26Ω series resistor on a side outputs
- Operating voltage range:
 $V_{CCA}(\text{Opr}) = 1.4\text{V}$ to 3.6V
 $V_{CCB}(\text{Opr}) = 1.4\text{V}$ to 3.6V
- Max data rates:
380Mbps (1.8V to 3.3V translation)
260Mbps (<1.8V to 3.3V translation)
260Mbps (translate to 2.5V)
210Mbps (translate to 1.5V)
- Latch-up performance exceeds 500mA (JESD 17)
- ESD performance:
HBM > 2000V (MIL STD 883 method 3015);
MM > 200V
- RoHS compliant for Flip-Chip package

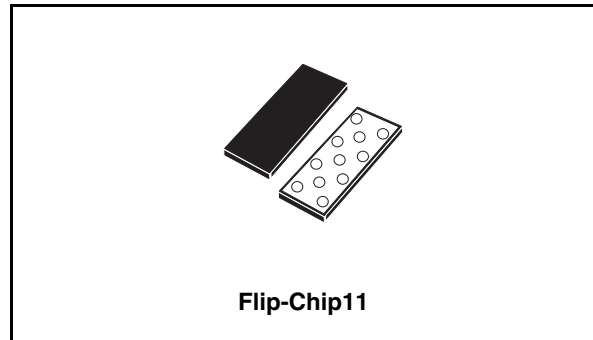

Description

The ST4G3235 is a dual supply low voltage CMOS 4-bit bus buffer level translator fabricated with sub-micron silicon gate and five-layer metal wiring C²MOS technology. Designed for use as an interface between a 3.3V bus and a 2.5V or 1.8V bus in a mixed 3.3V/1.8V, 3.3V/2.5V, 1.8V/1.4V and 2.5V/1.8V supply systems, it achieves high speed operation while maintaining the CMOS low power dissipation.

This IC is intended for one-way asynchronous communication between data buses. The input and output power down protections disable the device when both power supply are down, so that the buses are effectively isolated.

The input tolerant buffers allow to translate V_{CCB} compatible signals and greater signals than V_{CCB} up/down to V_{CCA} and viceversa.

All inputs are equipped with protection circuits against static discharge, giving them ESD immunity and transient excess voltage.

Table 1. Device summary

Part number	Package	Packaging
ST4G3235BJR	Flip-Chip11	4000 parts per reel

Contents

1	Pin settings	3
1.1	Pin connection	3
1.2	Pin description	3
2	Device summary	4
3	Maximum rating	5
3.1	Recommended operating conditions	6
4	Electrical characteristics	7
5	Test circuit	14
6	Waveforms	15
7	Package mechanical data	16
8	Revision history	20

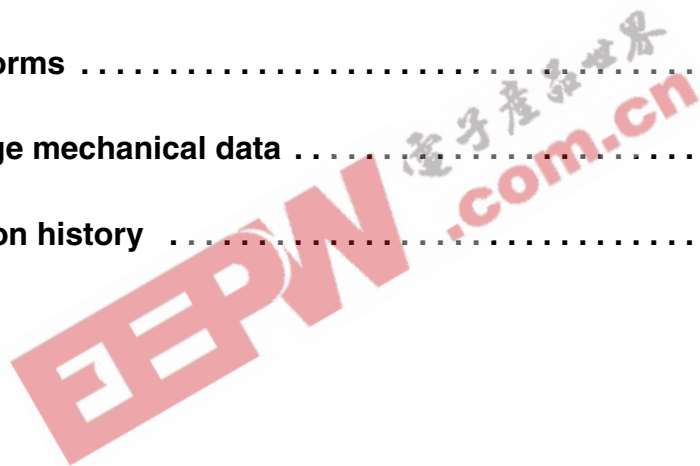

1 Pin settings

1.1 Pin connection

Figure 1. Pin connection (top through view)

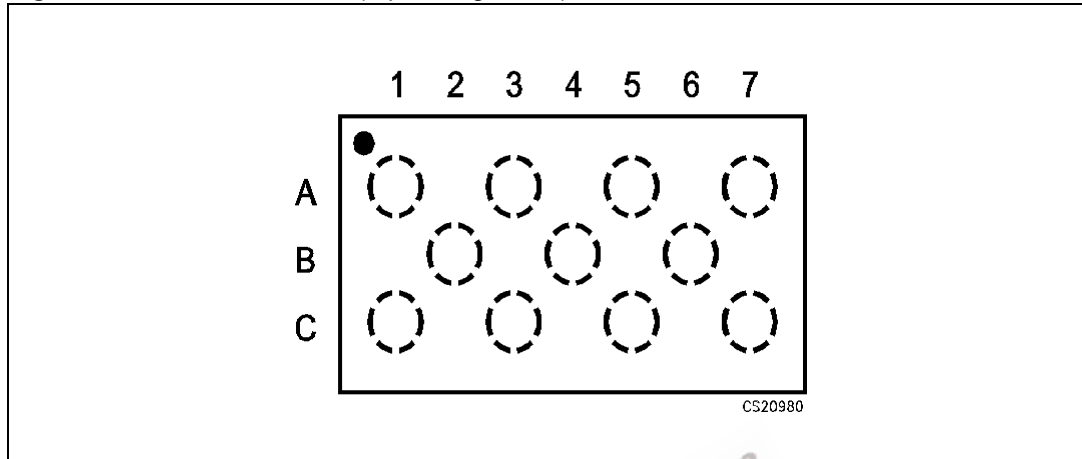

1.2 Pin description

Table 2. Pin description

Pin N°	Symbol	Name and function
A1	A4	Data input (V_{CCA} referred)
A3	A3	Data input (V_{CCA} referred)
A5	A2	Data output (V_{CCA} referred)
A7	A1	Data output (V_{CCA} referred)
C1	B4	Data output (V_{CCB} referred)
C3	B3	Data output (V_{CCB} referred)
C5	B2	Data input (V_{CCB} referred)
C7	B1	Data input (V_{CCB} referred)
B2	GND	Ground (0V)
B6	V_{CCA}	Positive supply voltage
B4	V_{CCB}	Positivoltage

2 Device summary

Figure 2. Input equivalent circuit

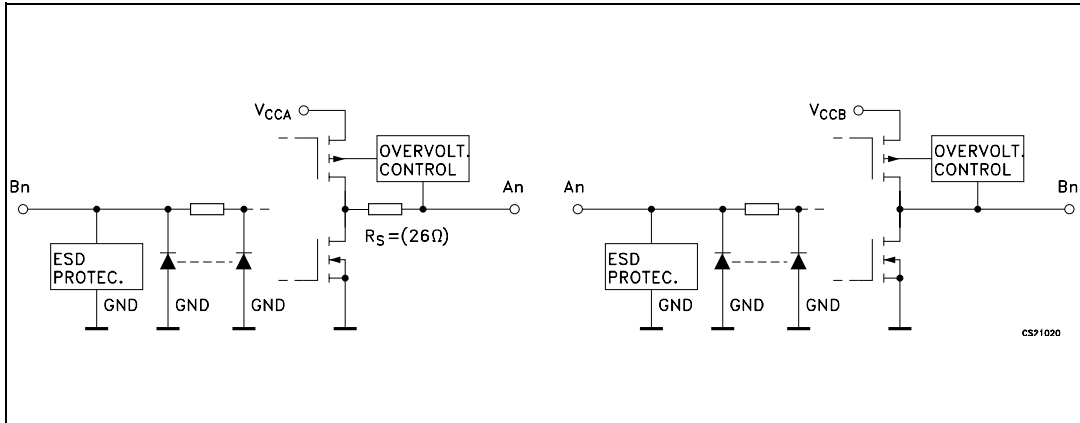

Figure 3. Logic diagram

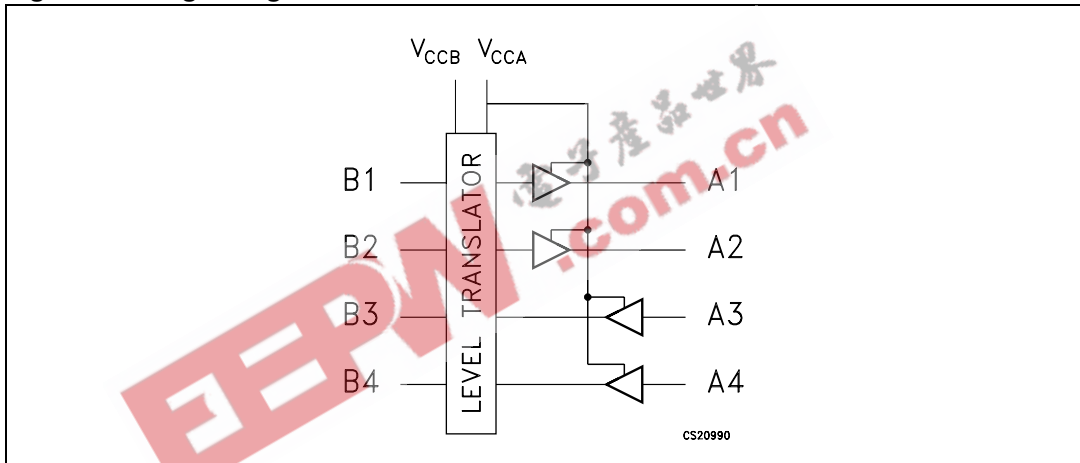

Table 3. Truth table

Inputs Bn (V _{CCB} Referred)	Outputs An (V _{CCA} Referred)
L	L
H	H
n = 1..2	
Inputs An (V _{CCB} Referred)	Outputs Bn (V _{CCA} Referred)
L	L
H	H
n = 3..4	

3 Maximum rating

Stressing the device above the rating listed in the “Absolute Maximum Ratings” table may cause permanent damage to the device. These are stress ratings only and operation of the device at these or any other conditions above those indicated in the Operating sections of this specification is not implied. Exposure to Absolute Maximum Rating conditions for extended periods may affect device reliability. Refer also to the STMicroelectronics SURE Program and other relevant quality documents.

Table 4. Absolute maximum ratings

Symbol	Parameter	Value	Unit
V_{CCA}	Output supply voltage	-0.5 to +4.6	V
V_{CCB}	Input supply voltage	-0.5 to $V_{CCA} + 0.5$	V
V_O	DC output voltage (Power down mode: $V_{CCA}=V_{CCB}=Gnd$)	-0.5 to +4.6	V
V_I	DC Input Voltage (Power down mode: $V_{CCA}=V_{CCB}=Gnd$)	-0.5 to +4.6	V
V_{OA}	DC output voltage (A1, A2 Outputs)	-0.5 to $V_{CCA} + 0.5$	V
V_{OB}	DC output voltage (B3, B4 Outputs)	-0.5 to $V_{CCA} + 0.5$	V
V_{IA}	DC input voltage (A3, A4 Inputs)	-0.5 to +4.6	V
V_{IB}	DC input voltage (B1, B2 Inputs)	-0.5 to +4.6	V
I_{IK}	DC input diode Current	- 20	mA
I_{OK}	DC output diode current	- 50	mA
I_{OA}	DC output current	± 50	mA
I_{CCA}	DC V_{CCA} or ground current	± 100	mA
I_{CCB}	DC V_{CCB} or ground current	± 100	mA
P_d	Power dissipation	400	mW
T_{stg}	Storage temperature	-65 to +150	°C
T_L	Lead temperature (10 sec)	260	°C

3.1 Recommended operating conditions

Table 5. Recommended operating conditions

Symbol	Parameter	Value	Unit	
V_{CCA}	Supply voltage	1.4 to 3.6	V	
V_{CCB}	Supply voltage	1.4 to 3.6	V	
V_{IB}	Input voltage (B1, B2)	0 to V_{CCB}	V	
V_{IA}	Input voltage (A3, A4)	0 to V_{CCA}	V	
V_{OB}	Output voltage (B3, B4)	0 to V_{CCB}	V	
V_{OA}	Output voltage (A1, A2)	0 to V_{CCA}	V	
T_{op}	Operating temperature	-40 to 85	°C	
dt/dv	Input rise and fall time ⁽¹⁾	$V_{CCB} = 3.0$ to $3.6V$	0 to 10	ns/V
		$V_{CCB} = 2.3$ to $2.7V$	0 to 20	ns/V
		$V_{CCB} = 1.4$ to $1.95V$	0 to 100	ns/V

1. VI from 0.8V to 2.0V at $V_{CC} = 3.0V$

EEPW 电子产品世界 .com.cn

4 Electrical characteristics

Table 6. DC Specification for V_{CCA}

Symbol	Parameter	Test condition			Value					Unit
		V_{CCB} (V) ⁽¹⁾	V_{CCA} (V) ⁽¹⁾		$T_A = 25\text{ °C}$			$-40\text{ to }85\text{ °C}$		
					Min.	Typ.	Max.	Min.	Max.	
V_{IHA}	High level input voltage (A3-A4)	1.4 to 3.6V	1.4		0.65 V_{CCA}			0.65 V_{CCA}		V
			1.8		0.65 V_{CCA}			0.65 V_{CCA}		
			2.5		1.6			1.6		
			3.3		2.0			2.0		
V_{ILA}	Low level input voltage (A3-A4)	1.4 to 3.6V	1.4				0.35 V_{CCA}		0.35 V_{CCA}	V
			1.8				0.35 V_{CCA}		0.35 V_{CCA}	
			2.5				0.7		0.7	
			3.3				0.8		0.8	
V_{OHA}	High level output voltage (A1-A2)	1.4 to 3.6V	1.4	$I_O = -100\mu A$	1.2			1.2		V
			2.75	$I_O = -0.4mA$	2.5			2.5		
			2.75	$I_O = -10mA$	2.2			2.2		
			2.3	$I_O = -6mA$	1.8			1.8		
			1.65	$I_O = -2mA$	1.4			1.4		
			1.4	$I_O = -1mA$	1.1			1.1		
V_{OLA}	Low level output voltage (A1-A2)	1.4 to 3.6V	1.4	$I_O = 100\mu A$			0.20		0.20	V
			2.75	$I_O = 1mA$			0.40		0.40	
			2.75	$I_O = 10mA$			0.55		0.55	
			2.3	$I_O = 6mA$			0.40		0.40	
			1.65	$I_O = 2mA$			0.25		0.25	
			1.4	$I_O = 1mA$			0.20		0.20	
I_{IA}	Input leakage current (A3-A4)	2.7	3.6	$V_{IA} = V_{CCA}$ or GND			± 0.5		± 5	μA
		1.4	2.7	$V_{IA} = 3.6V$ or GND			± 0.5		± 5	μA

Table 6. DC Specification for V_{CCA}

Symbol	Parameter	Test condition			Value					Unit
		V _{CCB} (V) ⁽¹⁾	V _{CCA} (V) ⁽¹⁾		T _A = 25 °C			-40 to 85 °C		
					Min.	Typ.	Max.	Min.	Max.	
I _{OFF}	Power off leakage current	0	0	V _{IB} =GND to 3.6V V _{OA} =GND to 3.6V V _{IA} =GND to 3.6V V _{OB} =GND to 3.6V			± 1.0		± 10	μA
I _{CCtA}	Quiescent supply current	1.4 to 3.6V	1.4 to 3.6V	V _{IA} =V _{CCA} or GND V _{IB} =V _{CCB} or GND			0.5		5	μA
ΔI _{CCtA}	Maximum quiescent supply current / Input (An)	2.7	3.6	V _{IA} =V _{CCA} - 0.6V					0.75	mA
		1.95	3.6							
		1.95	2.7	V _{IA} =V _{CCA} or GND V _{IB} =V _{CCB} or GND						

1. V_{CC} range = 3.3±0.3; 2.5±0.2V; 1.8±0.15V

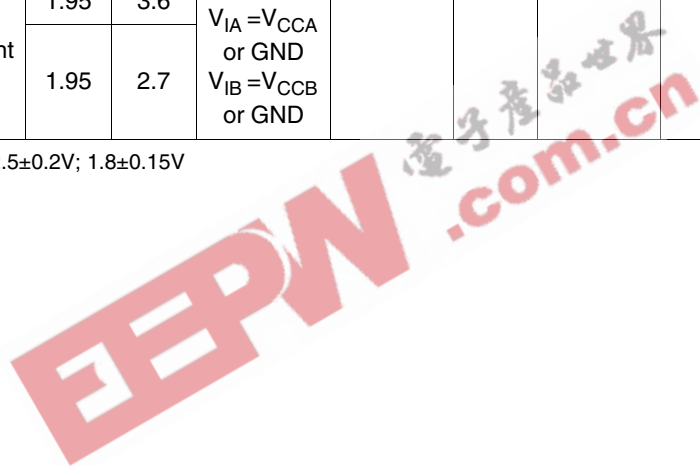

Table 7. DC Specification for V_{CCB}

Symbol	Parameter	Test condition			Value					Unit
		V_{CCB} (V) ⁽¹⁾	V_{CCA} (V) ⁽¹⁾		$T_A = 25\text{ }^\circ\text{C}$			$-40\text{ to }85\text{ }^\circ\text{C}$		
					Min.	Typ.	Max.	Min.	Max.	
V_{IHB}	High level input voltage (B1-B2)	1.4	1.4 to 3.6V		0.65 V_{CCB}			0.65 V_{CCB}		V
		1.8			0.65 V_{CCB}			0.65 V_{CCB}		
		2.5			1.6			1.6		
		3.3			2.0			2.0		
V_{ILB}	Low level input voltage (B1-B2)	1.4	1.4 to 3.6V				0.35 V_{CCB}		0.35 V_{CCB}	V
		1.8					0.35 V_{CCB}		0.35 V_{CCB}	
		2.5					0.7		0.7	
		3.3					0.8		0.8	
V_{OHB}	High level output voltage (B3-B4)	1.4	1.4 to 3.6V	$I_O = -100\mu\text{A}$	1.3			1.3		V
		1.8		$I_O = -100\mu\text{A}$	1.6			1.6		
		2.75		$I_O = -24\text{mA}$	2.2			2.2		
		2.75		$I_O = -18\text{mA}$	1.7			1.7		
		2.3		$I_O = -4\text{mA}$	1.44			1.44		
		1.65		$I_O = -4\text{mA}$	1.5			1.5		
		1.4		$I_O = -2\text{mA}$	1.25			1.25		
V_{OLB}	Low level output voltage (B3-B4)	1.4	1.4 to 3.6V	$I_O = 100\mu\text{A}$			0.1		0.1	V
		1.8		$I_O = 100\mu\text{A}$			0.2		0.2	
		2.75		$I_O = 24\text{mA}$			0.55		0.55	
		2.75		$I_O = 18\text{mA}$			0.35		0.35	
		2.3		$I_O = 4\text{mA}$			0.39		0.39	
		1.65		$I_O = 4\text{mA}$			0.20		0.20	
		1.4		$I_O = 2\text{mA}$			0.15		0.15	
I_{IB}	Input leakage current (B1-B2)	2.7	3.6	$V_{IB} = V_{CCB}$ or GND			± 0.5		± 5	μA
		1.4	2.7	$V_{IB} = 3.6\text{V}$ or GND			± 0.5		± 5	μA

Table 7. DC Specification for V_{CCB}

Symbol	Parameter	Test condition			Value					Unit
		V_{CCB} (V) ⁽¹⁾	V_{CCA} (V) ⁽¹⁾		$T_A = 25\text{ °C}$			-40 to 85 °C		
					Min.	Typ.	Max.	Min.	Max.	
I_{OFF}	Power off leakage current	0	0	$V_{IB}=\text{GND to } 3.6\text{V}$ $V_{OA}=\text{GND to } 3.6\text{V}$ $V_{IA}=\text{GND to } 3.6\text{V}$ $V_{OB}=\text{GND to } 3.6\text{V}$			± 1.0		± 10	μA
I_{CCtB}	Quiescent supply current	1.4 to 3.6V	1.4 to 3.6V	$V_{IA}=V_{CCA}$ or GND $V_{IB}=V_{CCB}$ or GND			0.5		5	μA
ΔI_{CCtB}	Maximum quiescent supply current / Input (Bn)	2.7	3.6	$V_{IB}=V_{CCB} - 0.6\text{V}$ $V_{IB}=V_{CCB}$ or GND					0.75	mA
		1.95	3.6							
		1.95	2.7	$V_{IB}=V_{CCA}$ or GND						

1. V_{CC} range = 3.3 ± 0.3 ; $2.5\pm 0.2\text{V}$; $1.8\pm 0.15\text{V}$

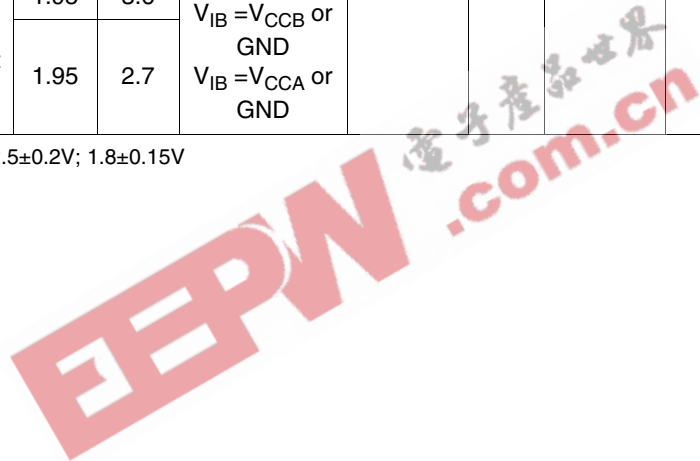

Table 8. Dynamic switching characteristics

Symbol	Parameter	Test condition			Value					Unit		
		V _{CCB} (V)	V _{CCA} (V)		T _A = 25 °C			-40 to 85 °C				
					Min.	Typ.	Max.	Min.	Max.			
V _{OLPA}	Dynamic low level Quiet An Output	1.4	1.8	C _L = 30pF V _{ILB} = 0V V _{IHB} = V _{CCB}		0.2				V		
		1.4-1.8	2.5			0.25						
		1.8-2.5	3.3			0.35						
V _{OLVA}	Dynamic low level Quiet An Output	1.4	1.8		C _L = 30pF V _{ILB} = 0V V _{IHB} = V _{CCB}		-0.2				V	
		1.4-1.8	2.5				-0.25					
		1.8-2.5	3.3				-0.35					
V _{OHVA}	Dynamic high level Quiet An Output	1.4	1.8			C _L = 30pF V _{ILB} = 0V V _{IHB} = V _{CCB}		1.6				V
		1.4-1.8	2.5					2.1				
		1.8-2.5	3.3					2.7				
V _{OLPB}	Dynamic low level Quiet Bn Output	1.4	1.8-2.5	C _L = 30pF V _{ILA} = 0V V _{IHA} = V _{CCA}				0.2				V
		1.8	2.5-3.3					0.25				
		2.5	3.3					0.6				
V _{OLVB}	Dynamic low level Quiet Bn Output	1.4	1.8-2.5		C _L = 30pF V _{ILA} = 0V V _{IHA} = V _{CCA}			-0.2				V
		1.8	2.5-3.3					-0.25				
		2.5	3.3					-0.36				
V _{OHVB}	Dynamic high level Quiet Bn Output	1.4	1.8-2.5			C _L = 30pF V _{ILA} = 0V V _{IHA} = V _{CCA}		1.2				V
		1.8	2.5-3.3					1.4				
		2.5	3.3					1.9				

Table 9. AC electrical characteristics

Symbol	Parameter	Test condition			Value		Unit
		V _{CCB} (V)	V _{CCA} (V)		-40 to 85 °C		
					Min.	Max.	
t _{PLH} t _{PHL}	Propagation delay time Bn to An	2.3 to 3.6	1.4	C _L = 10 pF	2.0	6.5	ns
		1.4 to 1.95	1.4		2.0	6.8	
		2.3 to 3.6	1.65 to 1.95		2.0	5.2	
		1.4 to 1.95	1.65 to 1.95		2.0	5.6	
		1.4 to 1.95	2.3 to 2.7		2.0	4.6	
		1.4 to 1.95	3.0 to 3.6		2.0	4.3	
		2.3 to 2.7	3.0 to 3.6		1.0	3.6	
t _{PLH} t _{PHL}	Propagation delay time Bn to An	2.3 to 3.6	1.4	C _L = 30 pF R _L = 500 Ω	2.0	7.5	ns
		1.4 to 1.95	1.4		2.0	7.5	
		2.3 to 3.6	1.65 to 1.95		2.0	6.5	
		1.4 to 1.95	1.65 to 1.95		2.0	6.7	
		1.4 to 1.95	2.3 to 2.7		2.0	5.9	
		1.4 to 1.95	3.0 to 3.6		2.0	5.7	
		2.3 to 2.7	3.0 to 3.6		1.0	4.9	
t _{PLH} t _{PHL}	Propagation delay time An to Bn	2.3 to 3.6	1.4	C _L = 10 pF	2.0	5.5	ns
		1.4 to 1.95	1.4		2.0	6.0	
		2.3 to 3.6	1.65 to 1.95		2.0	5.0	
		1.4 to 1.95	1.65 to 1.95		2.0	5.0	
		1.4 to 1.95	2.3 to 2.7		2.0	4.6	
		1.4 to 1.95	3.0 to 3.6		2.0	3.9	
		2.3 to 2.7	3.0 to 3.6		1.0	3.0	
t _{PLH} t _{PHL}	Propagation delay time An to Bn	2.3 to 3.6	1.4	C _L = 30 pF R _L = 500 Ω	2.0	7.0	ns
		1.4 to 1.95	1.4		2.0	7.5	
		2.3 to 3.6	1.65 to 1.95		2.0	6.0	
		1.4 to 1.95	1.65 to 1.95		2.0	6.0	
		1.4 to 1.95	2.3 to 2.7		2.0	5.6	
		1.4 to 1.95	3.0 to 3.6		2.0	4.6	
		2.3 to 2.7	3.0 to 3.6		1.0	4.0	
t _{OSLH} t _{OSHL}	Output to output skew time (note1, 2)	1.8 ± 0.15	2.5 ± 0.2	C _L = 30 pF R _L = 500 Ω		0.5	ns
		1.8 ± 0.15	3.3 ± 0.3			0.5	
		2.5 ± 0.2	3.3 ± 0.3			0.75	

Note: 1 Skew is defined as the absolute value of the difference between the actual propagation delay for any two outputs of the same device switching in the same direction, either HIGH or LOW (t_{OSLH} = | t_{PLHm} - t_{PLHn} |, t_{OSHL} = | t_{PHLm} - t_{PHLn} |
 2 Parameter guaranteed by design

Table 10. Capacitance characteristics

Symbol	Parameter	Test condition			Value					Unit
		V _{CCB} (V)	V _{CCA} (V)		T _A = 25 °C			-40 to 85 °C		
					Min.	Typ.	Max.	Min.	Max.	
C _{IN}	Input capacitance	open	open			6				pF
C _O	Output capacitance	1.8-2.5	2.5-3.3			9				pF
C _{PD}	Power dissipation capacitance	2.5	3.3	f=10MHz		50				pF
		1.8	3.3			28				
		1.4	2.5			22				
		1.4	1.8			15				
		3.3	1.8			28				

Note: 1 C_{PD} is defined as the value of the IC's internal equivalent capacitance which is calculated from the operating current consumption without load. (Refer to Test Circuit). Average current can be obtained by the following equation. $I_{CC(opr)} = C_{PD} \times V_{CC} \times f_{IN} + I_{CC}/4$ (per circuit)

EEPW 电子产品世界
www.eepw.com.cn

5 Test circuit

Figure 4. Test circuit

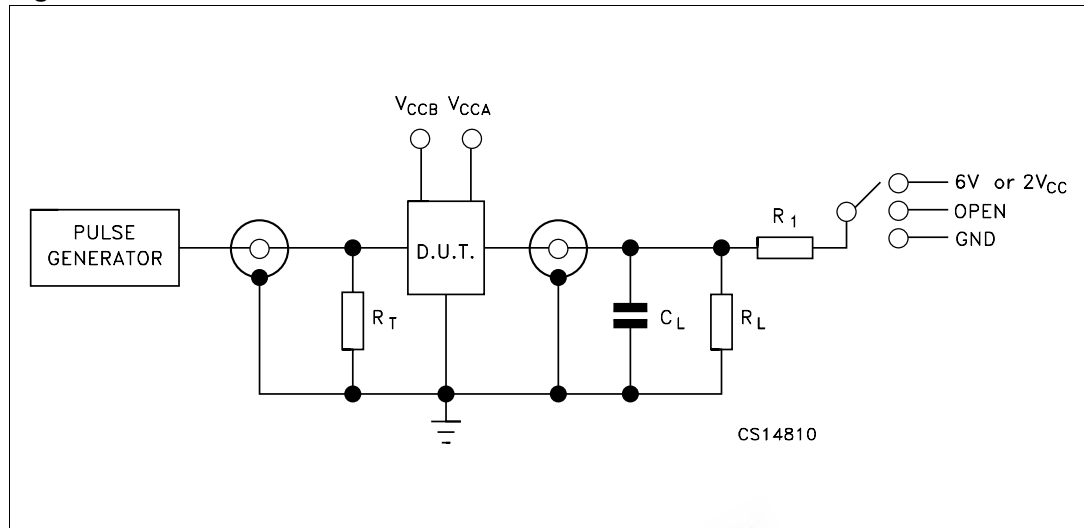

Table 11. Test circuit

Test	Switch
t_{PLH} , t_{PHL}	Open

$C_L = 10/30\text{pF}$ or equivalent (includes jig and probe capacitance)

$R_L = R_1 = 500\Omega$ or equivalent

$R_T = Z_{OUT}$ of pulse generator (typically 50Ω)

6 Waveforms

Table 12. Waveform symbol value

Symbol	V _{CC}		
	3.0 to 3.6V	2.3 to 2.7V	1.65 to 1.95V
V _{IH}	V _{CC}	V _{CC}	V _{CC}
V _M	1.5V	V _{CC} /2	V _{CC} /2
V _X	V _{OL} + 0.3V	V _{OL} + 0.15V	V _{OL} + 0.15V
V _Y	V _{OL} - 0.3V	V _{OL} - 0.15V	V _{OL} - 0.15V

Figure 5. Waveform - propagation delay (f=1MHz; 50% duty cycle)

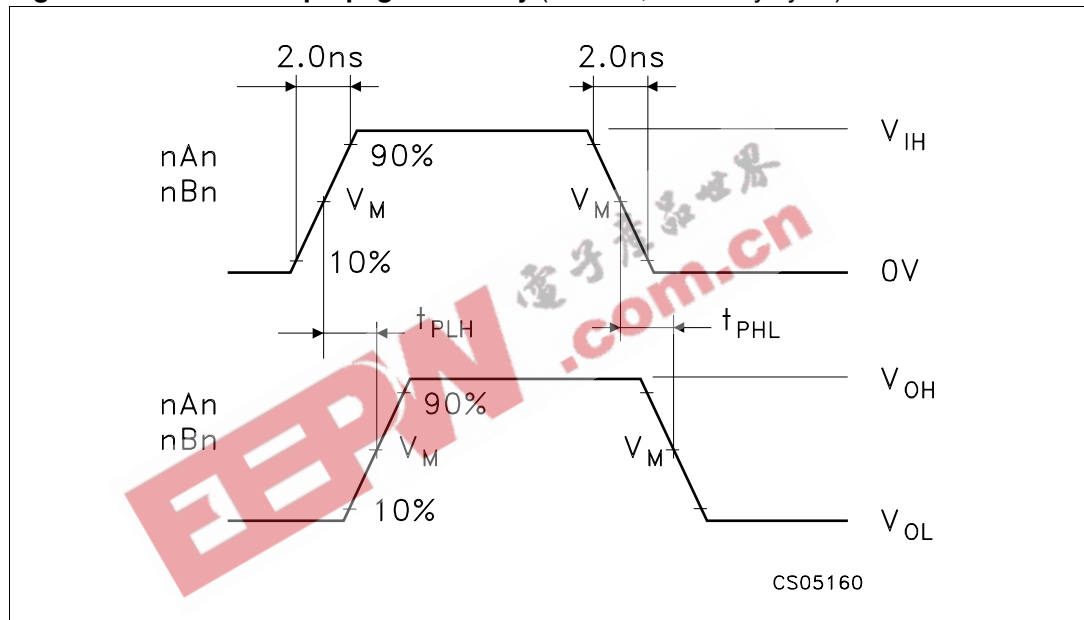

7 Package mechanical data

In order to meet environmental requirements, ST offers these devices in ECOPACK® packages. These packages have a Lead-free second level interconnect . The category of second level interconnect is marked on the package and on the inner box label, in compliance with JEDEC Standard JESD97. The maximum ratings related to soldering conditions are also marked on the inner box label. ECOPACK is an ST trademark. ECOPACK specifications are available at: www.st.com

EEPW 电子產品世界
.com.cn

Figure 6. Marking

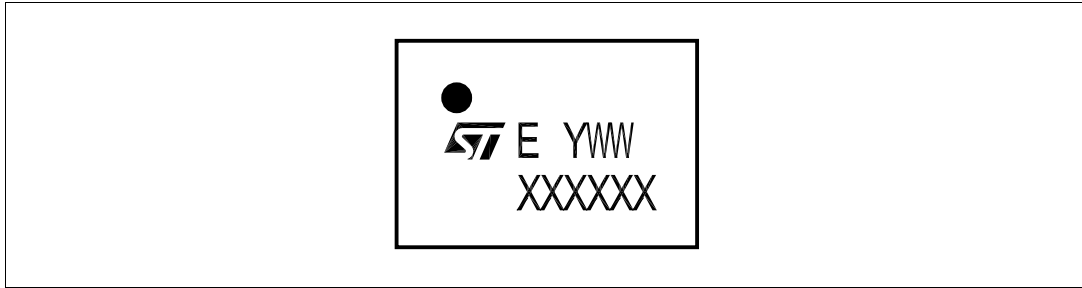

Note: E = Eco Level; Y = Assy Year; WW = Assy Week; X = Marking Area; Marking Code 9521

EEPW 电子产品世界
.com.cn

Table 13. Flip-Chip11 Mechanical data

Dim.	mm			inch		
	Min	Typ	Max	Min	Typ	Max
A	0.585	0.65	0.715	23.0	25.6	28.1
A1	0.21	0.25	0.29	8.3	9.8	11.4
A2		0.40			15.7	
b	0.265	0.315	0.365	10.4	12.4	14.4
D	1.99	2.04	2.09	78.3	80.3	82.3
D1		1.5			59.1	
E	1.36	1.41	1.46	53.5	55.5	57.5
E1		0.866			34.1	
eD	0.2	0.25	0.30	7.9	9.8	11.8
eE	0.383	0.433	0.483	15.1	17.0	19.0
fD		0.270			10.6	
fE		0.272			10.7	
ccc		0.080			3.1	

Figure 7. Package dimension

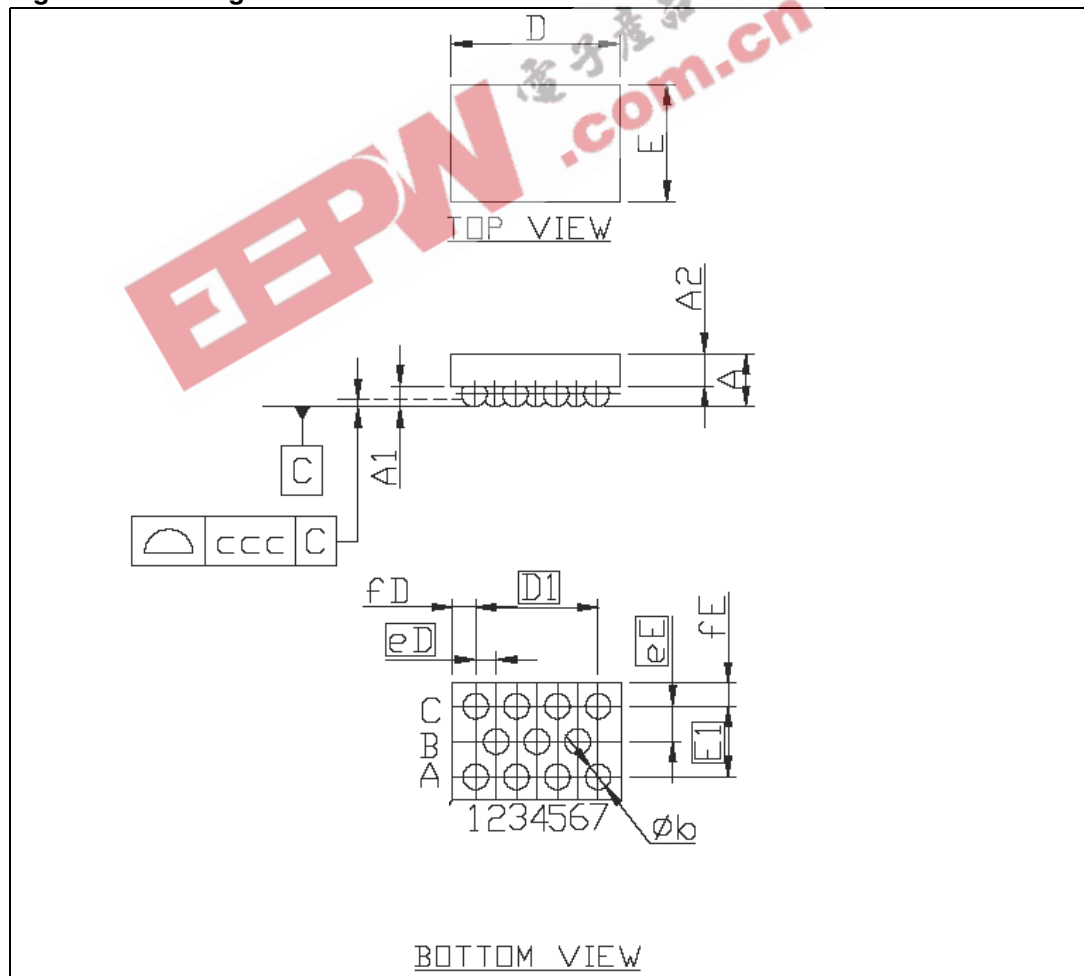
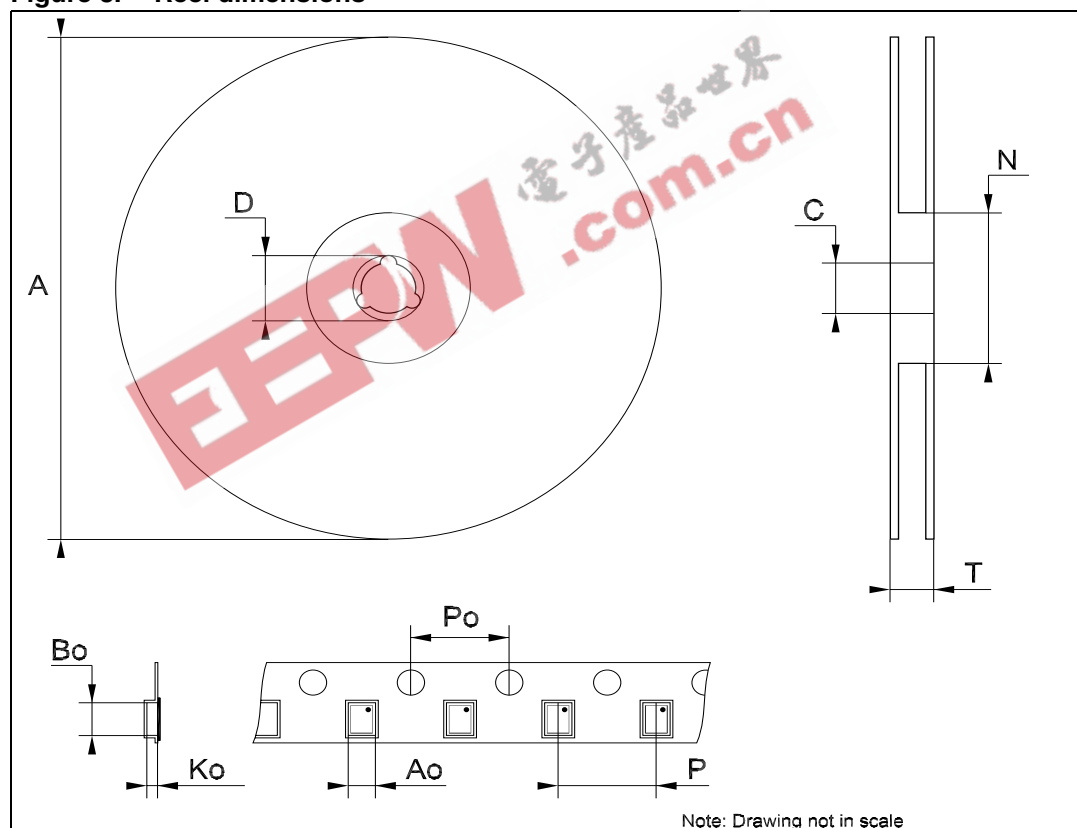

Table 14. Flip-Chip11 tape and reel information

Dim.	mm.			inch		
	Min	Typ	Max	Min	Typ	Max
A			178			6.926
C	12.8		13.2	0.504		0.519
D	20.2			0.795		
N	49	50	51	1.929	1.969	2.008
T			12.4			0.488
Ao	2.29	2.34	2.39	0.090	0.092	0.094
Bo	1.65	1.70	1.75	0.065	0.067	0.069
Ko	0.76	0.81	0.86	0.030	0.032	0.034
Po	3.9	4	4.1	0.153	0.157	0.161
P	3.9	4	4.1	0.153	0.157	0.161

Figure 8. Reel dimensions



8 Revision history

Table 15. Revision history

Date	Revision	Changes
14-Oct-2004	1	First release.
26-Oct-2004	2	Mechanical Data has been updated.
11-Feb-2005	3	Add Tape & Reel and Figure 6.
18-Feb-2005	4	Table 1 has been updated from 4000 to 5000 parts per Reel.
30-Mar-2005	5	Add Features ==> Max Data Rates.
09-May-2005	6	Table 9 and Table 10 have been updated.
14-Jun-2007	7	Document reformatted, typo Figure 2 on page 3

EEPW 电子产品世界
.com.cn

Please Read Carefully:

Information in this document is provided solely in connection with ST products. STMicroelectronics NV and its subsidiaries ("ST") reserve the right to make changes, corrections, modifications or improvements, to this document, and the products and services described herein at any time, without notice.

All ST products are sold pursuant to ST's terms and conditions of sale.

Purchasers are solely responsible for the choice, selection and use of the ST products and services described herein, and ST assumes no liability whatsoever relating to the choice, selection or use of the ST products and services described herein.

No license, express or implied, by estoppel or otherwise, to any intellectual property rights is granted under this document. If any part of this document refers to any third party products or services it shall not be deemed a license grant by ST for the use of such third party products or services, or any intellectual property contained therein or considered as a warranty covering the use in any manner whatsoever of such third party products or services or any intellectual property contained therein.

UNLESS OTHERWISE SET FORTH IN ST'S TERMS AND CONDITIONS OF SALE ST DISCLAIMS ANY EXPRESS OR IMPLIED WARRANTY WITH RESPECT TO THE USE AND/OR SALE OF ST PRODUCTS INCLUDING WITHOUT LIMITATION IMPLIED WARRANTIES OF MERCHANTABILITY, FITNESS FOR A PARTICULAR PURPOSE (AND THEIR EQUIVALENTS UNDER THE LAWS OF ANY JURISDICTION), OR INFRINGEMENT OF ANY PATENT, COPYRIGHT OR OTHER INTELLECTUAL PROPERTY RIGHT.

UNLESS EXPRESSLY APPROVED IN WRITING BY AN AUTHORIZED ST REPRESENTATIVE, ST PRODUCTS ARE NOT RECOMMENDED, AUTHORIZED OR WARRANTED FOR USE IN MILITARY, AIR CRAFT, SPACE, LIFE SAVING, OR LIFE SUSTAINING APPLICATIONS, NOR IN PRODUCTS OR SYSTEMS WHERE FAILURE OR MALFUNCTION MAY RESULT IN PERSONAL INJURY, DEATH, OR SEVERE PROPERTY OR ENVIRONMENTAL DAMAGE. ST PRODUCTS WHICH ARE NOT SPECIFIED AS "AUTOMOTIVE GRADE" MAY ONLY BE USED IN AUTOMOTIVE APPLICATIONS AT USER'S OWN RISK.

Resale of ST products with provisions different from the statements and/or technical features set forth in this document shall immediately void any warranty granted by ST for the ST product or service described herein and shall not create or extend in any manner whatsoever, any liability of ST.

ST and the ST logo are trademarks or registered trademarks of ST in various countries.

Information in this document supersedes and replaces all information previously supplied.

The ST logo is a registered trademark of STMicroelectronics. All other names are the property of their respective owners.

© 2007 STMicroelectronics - All rights reserved

STMicroelectronics group of companies

Australia - Belgium - Brazil - Canada - China - Czech Republic - Finland - France - Germany - Hong Kong - India - Israel - Italy - Japan - Malaysia - Malta - Morocco - Singapore - Spain - Sweden - Switzerland - United Kingdom - United States of America

www.st.com