

PRELIMINARY W541E20X



4-BIT FLASH EPROM MICROCONTROLLER

GENERAL DESCRIPTION

The W541E20X is fully compatible with W741E20X in terms of pin assignment and IC function. It is a high-performance 4-bit microcontroller (μC) that provides an flash EEPROM for the program memory. The device contains a 4-bit ALU, two 8-bit timers, a divider, a serial port, and five 4-bit I/O ports (including 3 output port for LED driving). There are also seven interrupt sources and 8-level subroutine nesting for interrupt applications. The W541E20X has two power reduction modes, hold mode and stop mode, which help to minimize power dissipation.

The W541E20X is suitable for end product manufacturer engineering testing and earlier samples before mass production.

FEATURES

- Operating voltage: 2.4V–5.5V
- Crystal or RC oscillation circuit can be selected by the code option
 - Crystal/Ceramic oscillator: up to 4 MHz
 - RC oscillator: up to 4 MHz
- Both in crystal or RC oscillator operation mode, high-frequency (400 KHz to 4 MHz) or low-frequency (32.768 KHz) oscillation must be determined by the code option
- Memory
 - 2048 \times 16 bit program flash EEPROM (including 2K \times 4 bit look-up table)
 - 128 \times 4 bit data RAM (including 16 working registers)
- 21 input/output pins
 - Input/output ports: 4 ports/16 pins
 - Serial input/output port: 1 port /4 pins (high sink current for LED driving)
 - MFP output pin: 1 pin (MFP)
 - **Do not be floating when it is as input or output open-drain (NMOS type).**
- Power-down mode
 - Hold function: no operation (except for oscillator)
 - Stop function: no operation (including oscillator)
- Seven types of interrupts
 - Five internal interrupts (Divider 0, Timer 0, Timer 1, and Serial I/O)
 - Two external interrupts (Port RC and $\overline{\text{INT}}$ pin)
- MFP output pin
 - Output is software selectable as modulating or nonmodulating frequency
 - Works as frequency output specified by Timer 1
- Built-in 14-bit clock frequency divider circuit
- Two built-in 8-bit programmable countdown timers
 - Timer 0: One of two internal clock frequencies ($F_{\text{osc}}/4$ or $F_{\text{osc}}/1024$) can be selected

Preliminary W541E20X



- Timer 1: Offers auto-reload function and one of two internal clock frequencies (Fosc or Fosc/64) can be selected or falling edge of pin RC.0 can be selected (output through MFP pin)
- Built-in 18/14-bit watchdog timer selectable for system reset
- Powerful instruction set: 118 instructions
- 8-level subroutine (include interrupt) nesting
- One serial transmission/receiver port specified by software
- Up to 1 μ S instruction cycle (with 4 MHz operating frequency)
- Packaged in 18-pin, 20-pin, 28-pin PDIP and 20-pin, 28-pin SOP

EEPW 电子產品世界
.com.cn

Preliminary W541E20X



BLOCK DIAGRAM

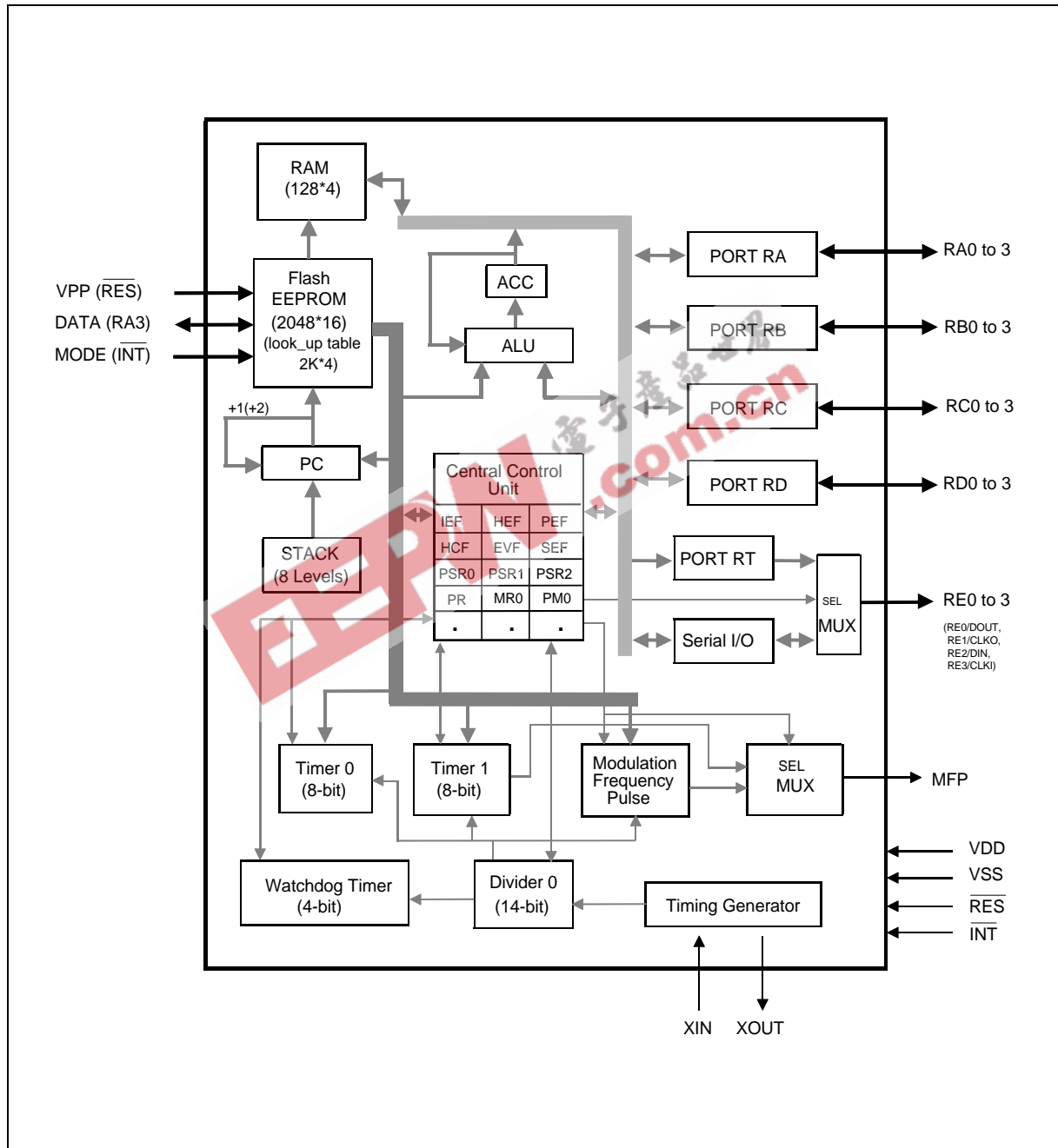

PIN CONFIGURATIONS

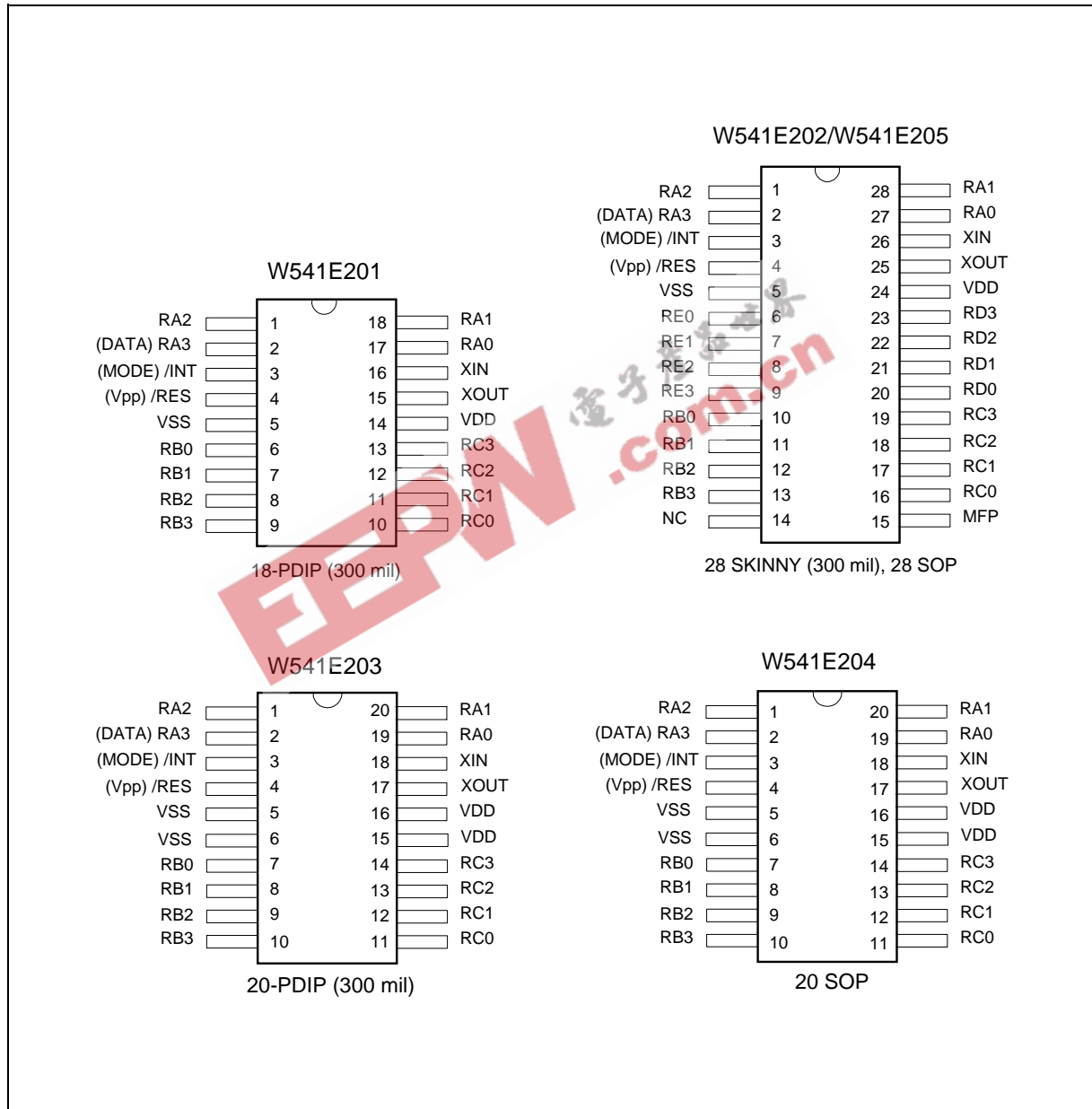

Preliminary W541E20X



PIN DESCRIPTION

SYMBOL	I/O	FUNCTION
XIN	I	Input pin for oscillator. Connected to crystal or resistor to generate system clock by code option. External 10~20pF capacitor uses to get accurate freq in crystal mode.
XOUT	O	Output pin for oscillator. Connected to crystal or resistor to generate system clock by code option. 20pF capacitor is built in internal for crystal mode.
RA0–RA2, RA3 (DATA)	I/O	Input/Output port. Input/output mode specified by port mode 1 register (PM1). When used as output port, can provide high sink current for driving LED.
RB0–RB3	I/O	Input/Output port. Input/output mode specified by port mode 2 register (PM2). When used as output port, can provide high sink current for driving LED.
RC0–RC3	I/O	Input/Output port. Input/output mode specified by port mode 4 register (PM4). Each pin has an independent interrupt capability in input mode.
RD0–RD3	I/O	Input/Output port. Input/output mode specified by port mode 5 register (PM5).
RE0/DOUT, RE1/CLKO, RE2/DIN, RE3/CLKI	I/O	Special input/output port. This port can be configured by software to act as the output of internal port RT or the serial I/O port. When used as output port, can provide high sink current for driving LED.
MFP	O	Output pin only. This pin can output modulating or nonmodulating frequency, or Timer 1 clock output specified by mode register 1 (MR1).
$\overline{\text{INT}}$ (MODE) ¹	I	External interrupt pin. This pin must be tied to VDD through an external resistor. It is a low active and floating input pin.
$\overline{\text{RES}}$ (VPP) ¹	I	System reset pin. This pin must be tied to VDD through an external resistor when it is not used to reset this chip. It is a low active and floating input pin.
VDD	I	Positive power supply (+).
VSS	I	Negative power supply (-).

Note: There are internal pull-high resistors in these pins of W741C20X.

Preliminary W541E20X



ABSOLUTE MAXIMUM RATINGS

PARAMETER	RATING	UNIT
Supply Voltage to Ground Potential	-0.3 to +7.0	V
Applied Input/Output Voltage	-0.3 to +7.0	V
Power Dissipation	120	mW
Ambient Operating Temperature	0 to +70	°C
Storage Temperature	-55 to +150	°C

Note: Exposure to conditions beyond those listed under Absolute Maximum Ratings may adversely affect the life and reliability of the device.

DC CHARACTERISTICS

(VDD-VSS = 3.0 V, Fosc. = 32.768 KHz, Ta = 25° C; unless otherwise specified)

PARAMETER	SYM.	CONDITIONS	MIN.	TYP.	MAX.	UNIT
Op. Voltage	VDD	-	2.4	-	5.5	V
Op. Current (Crystal type)	IOP1	No load (Ext-V)	-	8.5	20	μA
Op. Current (RC type)	IOP2	No load (Ext-V)	-	36	65	μA
Hold Current (Crystal type)	IHM1	Hold mode No load (Ext-V)	-	4	6	μA
Hold Current (RC type)	IHM2	Hold mode No load (Ext-V)	-	16	40	μA
Stop Current (Crystal type)	ISM1	Stop mode No load (Ext-V)	-	0.1	2	μA
Stop Current (RC type)	ISM2	Stop mode No load (Ext-V)	-	0.1	2	μA
Input Low Voltage	VIL	-	VSS	-	0.3 VDD	V
Input High Voltage	VIH	-	0.7 VDD	-	VDD	V
MFP Output Low Voltage	VML	IOL = 3.5mA	-	-	0.4	V
MFP Output High Voltage	VMH	IOH = -3.5mA	2.4	-	-	V
Port RA, RB Sink Current	IABL	VOL = 0.9V	9	-	-	mA
Port RA, RB Source Current	IABH	VOH = 2.4V	0.4	1.2	-	mA
Port RC, RD Output Low Voltage	VCDL	IOL = 2.0 mA	-	-	0.4	V
Port RC, RD Output High Voltage	VCDH	IOH = -2.0 mA	2.4	-	-	V
Port RE Sink Current	IEL	VOL = 0.9V	9	-	-	mA
Port RE Source Current	IEH	VOH = 2.4V	0.4	1.2	-	mA
DIN Pin Pull-up Resistor	RDIN	RE.2 used as serial input pin	50	250	1000	KΩ

Preliminary W541E20X



AC CHARACTERISTICS

(VDD-VSS = 3.0 V, Ta = 25° C; unless otherwise specified)

PARAMETER	SYM.	CONDITIONS	MIN.	TYP.	MAX.	UNIT
Op. Frequency	Fosc	RC type	-	-	4000	KHz
		Crystal type 1 (Option low speed type)	-	32.768	-	
		Crystal type 2 (Option high speed type)	400	-	3580	
Frequency Deviation by Voltage Drop for low freq. RC Oscillator	$\frac{\Delta f}{f}$	$\frac{f(3V) - f(2.4V)}{f(3V)}$	-	-	10	%
Instruction Cycle Time	Ti	One machine cycle	-	4/Fosc	-	S
Serial Port Data Ready Time	TDR	-	200	-	-	nS
Serial Port Data Hold Time	TDH	-	200	-	-	nS
Reset Active Width	TRAW	Fosc = 32.768 KHz	1	-	-	μS
Interrupt Active Width	TIAW	Fosc = 32.768 KHz	1	-	-	μS

Preliminary W541E20X



TYPICAL APPLICATION CIRCUIT

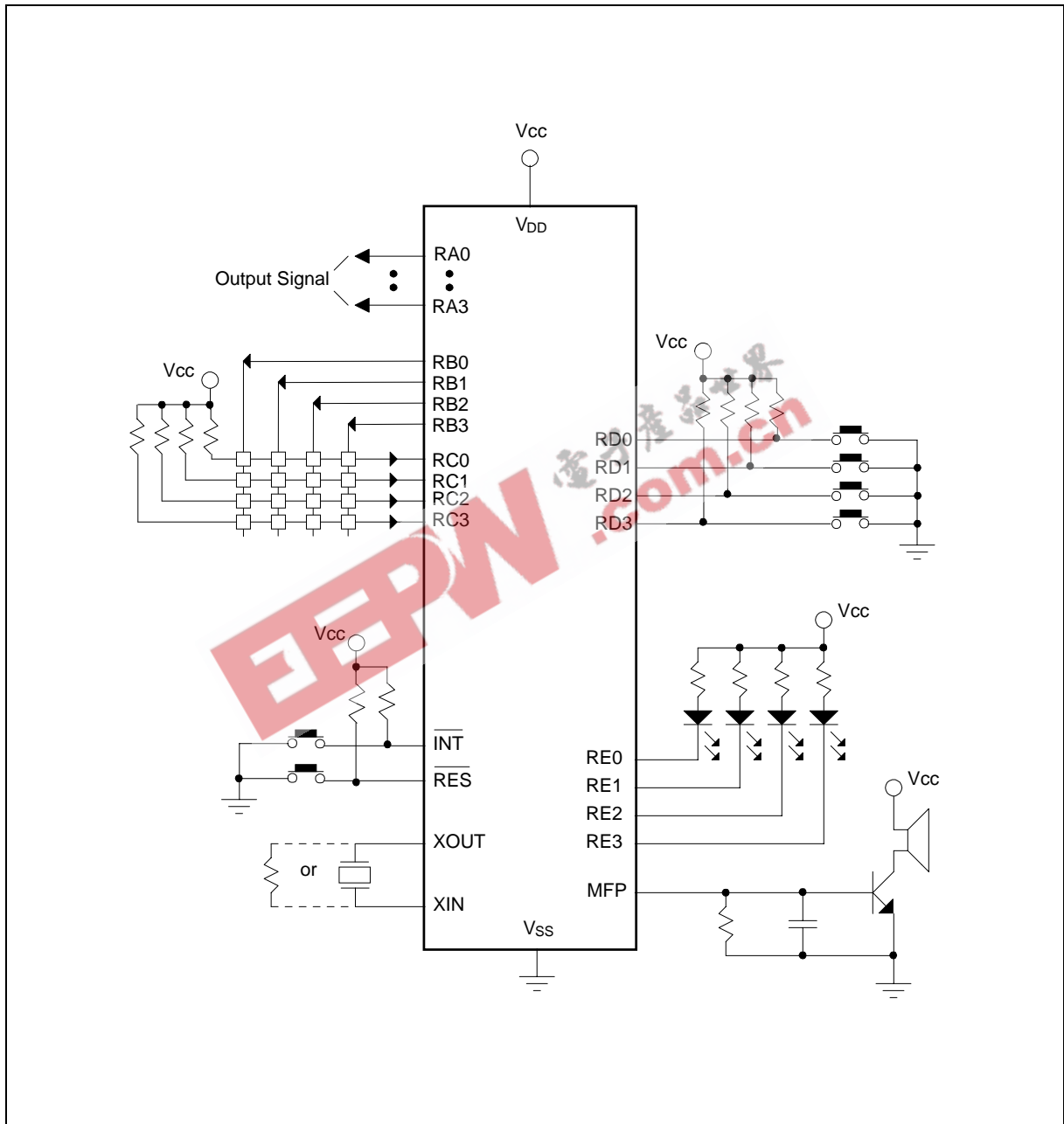

PACKAGE DIMENSIONS

18-Lead PDIP (300 mil)

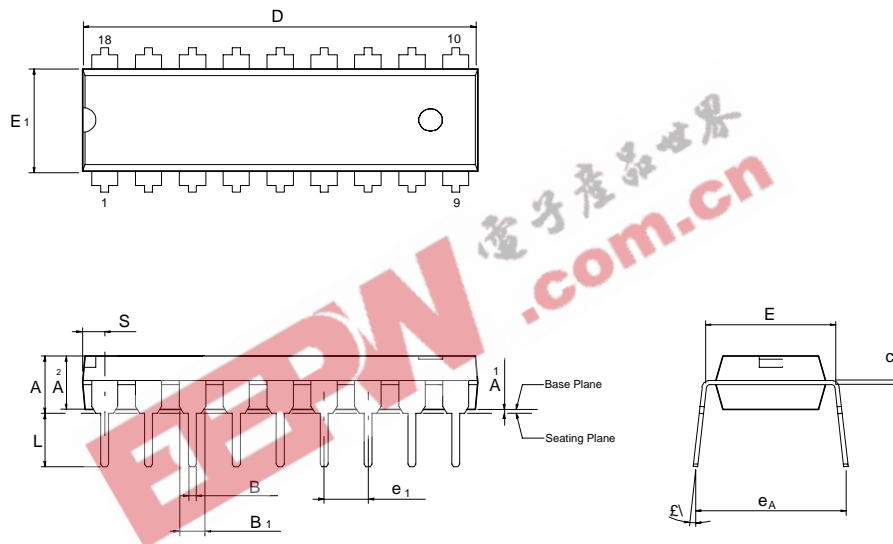

Symbol	Dimension in inch			Dimension in mm		
	Min.	Nom.	Max.	Min.	Nom.	Max.
A	—	—	0.175	—	—	4.45
A ₁	0.010	—	—	0.25	—	—
A ₂	0.125	0.130	0.135	3.18	3.30	3.43
B	0.016	0.018	0.022	0.41	0.46	0.56
B ₁	0.058	0.060	0.064	1.47	1.52	1.63
C	0.008	0.010	0.014	0.20	0.25	0.36
D	—	0.900	0.910	—	22.86	23.11
E	0.290	0.300	0.310	7.37	7.62	7.87
E ₁	0.245	0.250	0.255	6.22	6.35	6.48
e ₁	0.090	0.100	0.110	2.29	2.54	2.79
L	0.120	0.130	0.140	3.05	3.30	3.56
∅	0	—	15	0	—	15
e _A	0.335	0.355	0.375	8.51	9.02	9.53
S	—	—	0.055	—	—	1.40

Preliminary W541E20X



Package Dimensions, continued

20-Lead PDIP

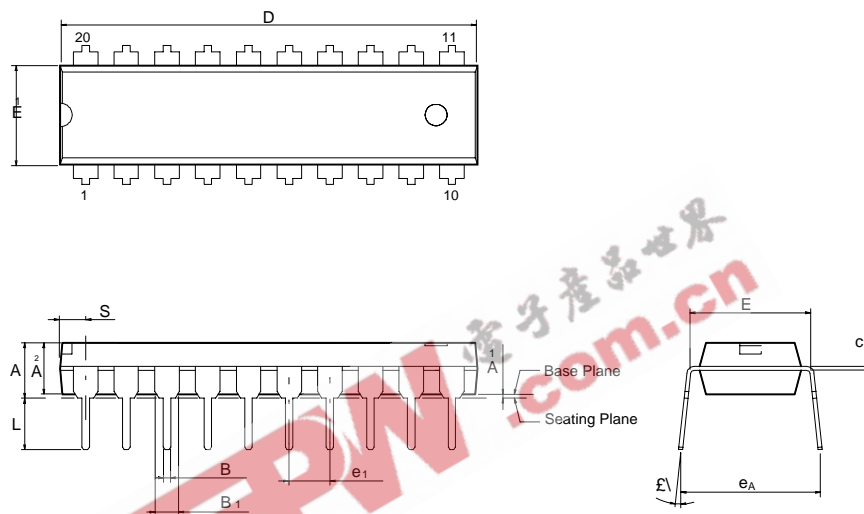

Symbol	Dimension in inch			Dimension in mm		
	Min.	Nom.	Max.	Min.	Nom.	Max.
A	—	—	0.175	—	—	4.45
A ₁	0.010	—	—	0.25	—	—
A ₂	0.125	0.130	0.135	3.18	3.30	3.43
B	0.016	0.018	0.022	0.41	0.46	0.56
B ₁	0.058	0.060	0.064	1.47	1.52	1.63
c	0.008	0.010	0.014	0.20	0.25	0.36
D	—	1.026	1.040	—	20.06	26.42
E	0.290	0.300	0.310	7.37	7.62	7.87
E ₁	0.245	0.250	0.255	6.22	6.35	6.48
e ₁	0.090	0.100	0.110	2.29	2.54	2.79
L	0.120	0.130	0.140	3.05	3.30	3.56
£\	0	—	15	0	—	15
e _A	0.335	0.355	0.375	8.51	9.02	9.53
S	—	—	0.075	—	—	1.91

Preliminary W541E20X



Package Dimensions, continued

28-Lead PDIP Skinny

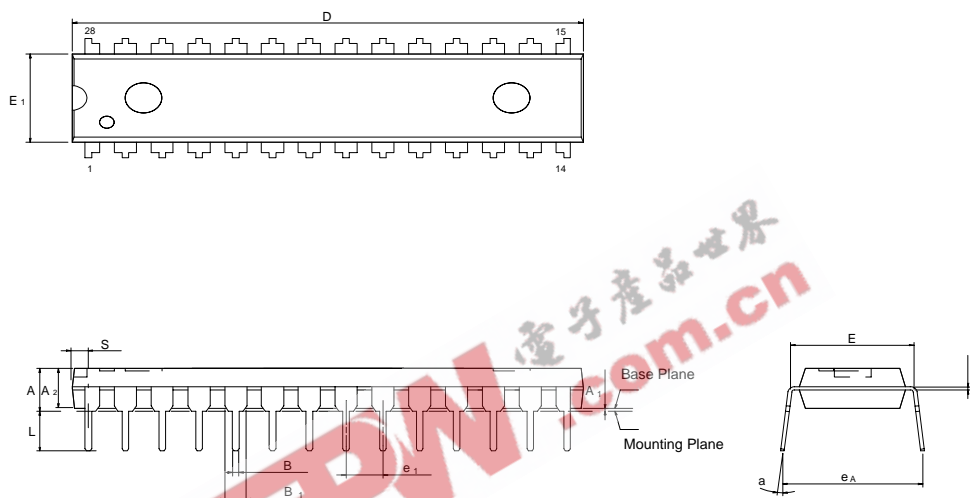

Symbol	Dimension in Inches			Dimension in mm		
	Min.	Nom.	Max.	Min.	Nom.	Max.
A	—	—	0.175	—	—	4.45
A ₁	0.010	—	—	0.25	—	—
A ₂	0.125	0.130	0.135	3.18	3.30	3.43
B	0.016	0.018	0.022	0.41	0.46	0.56
B ₁	0.058	0.060	0.064	1.47	1.52	1.63
c	0.008	0.010	0.014	0.20	0.25	0.36
D	—	1.388	1.400	—	35.26	35.56
E	0.300	0.310	0.320	7.62	7.87	8.13
E ₁	0.283	0.288	0.293	7.19	7.32	7.44
e ₁	0.090	0.100	0.110	2.29	2.54	2.79
L	0.120	0.130	0.140	3.05	3.30	3.56
a	0°	—	15°	0°	—	15°
e _A	0.330	0.350	0.370	8.38	8.89	9.40
S	—	—	0.055	—	—	1.40

Preliminary W541E20X



Package Dimensions, continued

20-Lead SOP (300mil)

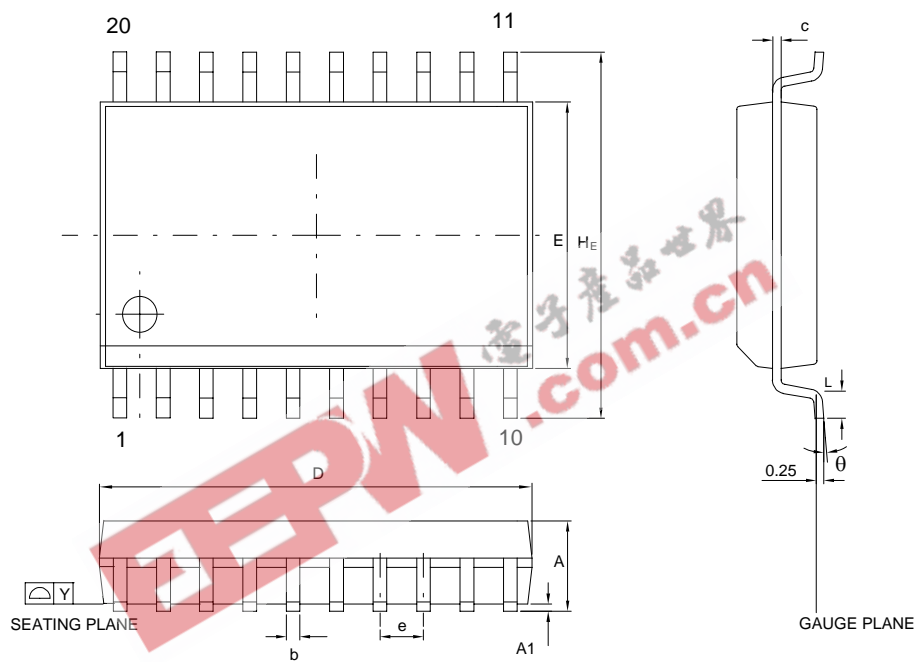

Control dimensions are in millimeters.

Symbol	Dimension in mm		Dimension in Inches	
	Min.	Max.	Min.	Max.
A	2.35	2.65	0.093	0.104
A1	0.10	0.30	0.004	0.012
b	0.33	0.51	0.013	0.020
c	0.23	0.32	0.009	0.013
E	7.40	7.60	0.291	0.299
D	12.60	13.00	0.496	0.512
e	1.27 BSC		0.050 BSC	
HE	10.00	10.65	0.394	0.419
Y	—	0.10	—	0.004
L	0.40	1.27	0.016	0.050
θ	0	8	0	8

Preliminary W541E20X



Package Dimensions, continued

28-Lead SOP (300 mil)

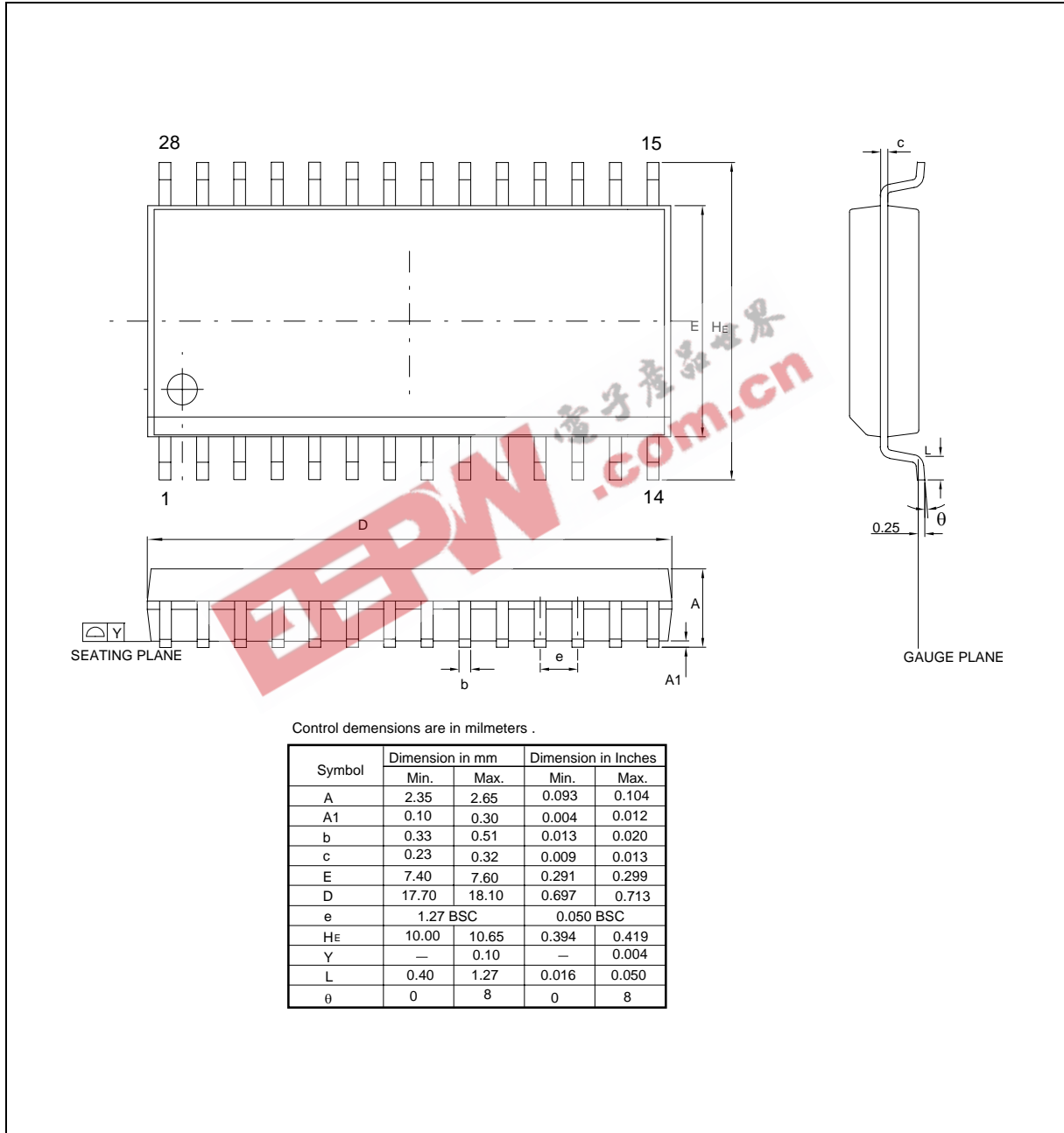

Preliminary W541E20X



Notes:

EEPW 电子產品世界 .com.cn



Headquarters

No. 4, Creation Rd. III,
Science-Based Industrial Park,
Hsinchu, Taiwan
TEL: 886-3-5770066
FAX: 886-3-5792766
<http://www.winbond.com.tw/>
Voice & Fax-on-demand: 886-2-27197006

Taipei Office

11F, No. 115, Sec. 3, Min-Sheng East Rd.,
Taipei, Taiwan
TEL: 886-2-27190505
FAX: 886-2-27197502

Winbond Electronics (H.K.) Ltd.

Rm. 803, World Trade Square, Tower II,
123 Hoi Bun Rd., Kwun Tong,
Kowloon, Hong Kong
TEL: 852-27513100
FAX: 852-27552064

Winbond Electronics North America Corp.

Winbond Memory Lab.
Winbond Microelectronics Corp.
Winbond Systems Lab.
2727 N. First Street, San Jose,
CA 95134, U.S.A.
TEL: 408-9436666
FAX: 408-5441798

Note: All data and specifications are subject to change without notice.