

**CONNECTOR DESIGNATORS**  
**A-B\*-C-D-E-F**  
**G-H-J-K-L-S**  
 \* Conn. Desig. B See Note 6  
**DIRECT COUPLING**

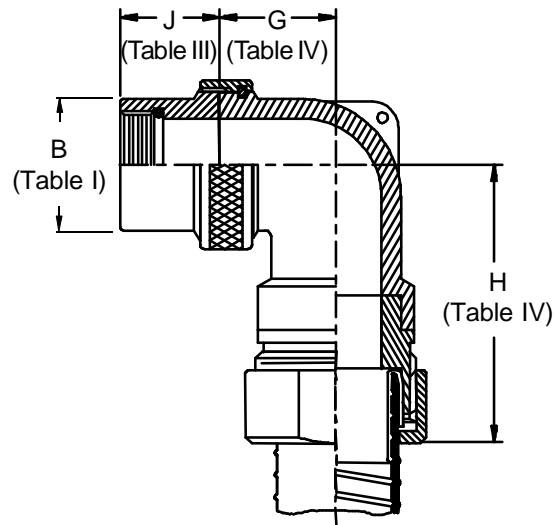

**420-002**  
**Sealtite™/Liquidite Conduit Backshell**  
**Direct Coupling - Low Profile**

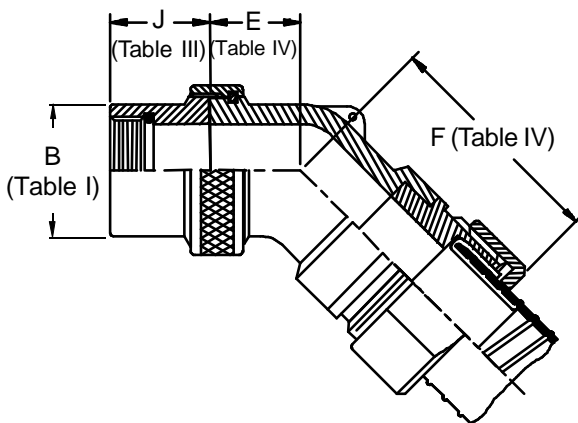
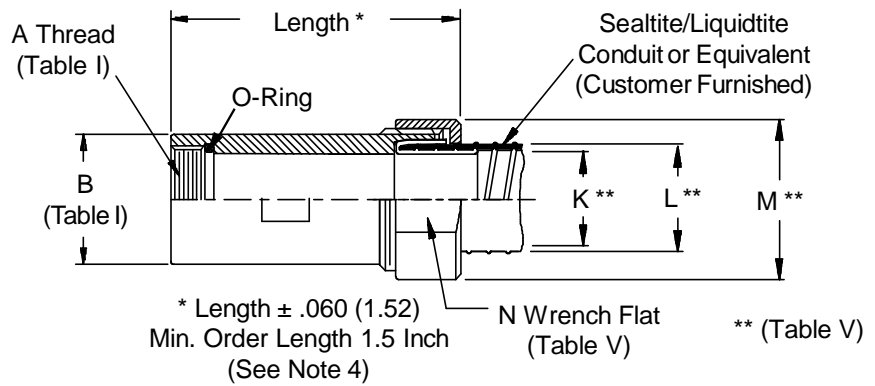
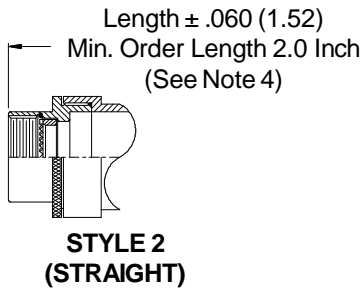
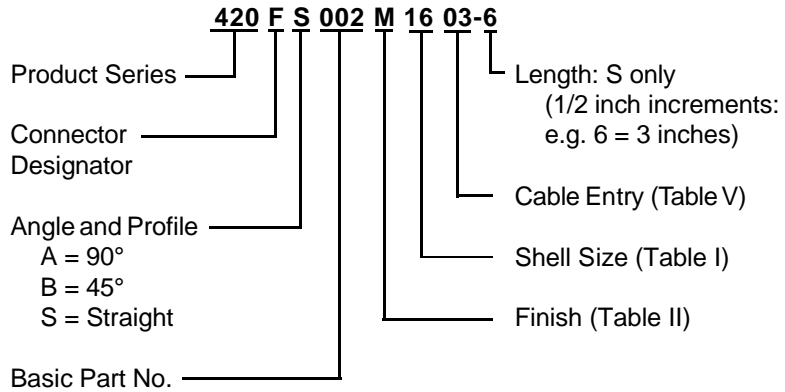

**TABLE III: FRONT ADAPTER**

Shell Size	J Max - Conn. Designator		
	A-E-F J-H-L-S	D-B-G-K	C
08/09	1.180 (30.0)	1.250 (31.8)	
10/11	1.180 (30.0)	1.250 (31.8)	
12/13	1.180 (30.0)	1.250 (31.8)	1.735 (44.1)
14/15	1.180 (30.0)	1.250 (31.8)	1.915 (48.6)
16/17	1.380 (35.0)	1.560 (39.6)	1.915 (48.6)
18/19	1.380 (35.0)	1.560 (39.6)	1.915 (48.6)
20/21	1.380 (35.0)	1.560 (39.6)	1.915 (48.6)
22/23	1.380 (35.0)	1.560 (39.6)	1.915 (48.6)
24/25	1.380 (35.0)	1.560 (39.6)	1.915 (48.6)
28/29	1.610 (40.9)	1.560 (39.6)	1.915 (48.6)
32/33	1.610 (40.9)	1.750 (44.5)	1.915 (48.6)
36	1.610 (40.9)	1.750 (44.5)	1.915 (48.6)
40	1.610 (40.9)	2.190 (55.6)	1.915 (48.6)

See inside back cover  
 fold-out or pages 13 and  
 14 for Tables I and II.

1. When maximum cable entry (page 22) is exceeded, Style 2 will be supplied. (Function S only).
2. Metric dimensions (mm) are indicated in parentheses.
3. Cable range is defined as the accommodations range for the wire bundle or cable. Dimensions shown are not intended for inspection criteria.
4. Consult factory for shorter lengths on straight backshells.
5. Sealtite is a trademark of Anaconda Corp.
6. When using Connector Designator B refer to pages 18 and 19 for part number development.

**TABLE IV: ELBOW DIMENSIONS**

Elbow Size	E Max	F Max	G Max	H Max
01	.630 (16.0)	1.870 (47.5)	.709 (18.0)	1.940 (49.3)
02	.692 (17.6)	1.930 (49.0)	.734 (18.6)	1.960 (49.8)
03	.848 (21.5)	2.130 (54.1)	.990 (25.1)	2.120 (53.8)
04	1.036 (26.3)	2.320 (58.9)	1.090 (27.7)	2.290 (58.2)
05	1.130 (28.7)	2.470 (62.7)	1.325 (33.7)	2.400 (61.0)
06	1.317 (33.5)	2.620 (66.5)	1.827 (46.4)	2.820 (71.6)
07	1.348 (34.2)	2.710 (68.8)	2.027 (51.5)	2.820 (71.6)

**TABLE V: CABLE ENTRY**

Dash No.	Conduit Size (Ref.)	K Dimension		L Dimension		M Max	N Max Wrench Flat
		Min	Max	Min	Max		
01	3/8	.484 (12.3)	.504 (12.8)	.690 (17.5)	.710 (18.0)	1.155 (29.3)	1.000 (25.4)
02	1/2	.622 (15.8)	.642 (16.3)	.820 (20.8)	.840 (21.3)	1.282 (32.6)	1.125 (28.6)
03	3/4	.820 (20.8)	.840 (21.3)	1.030 (26.2)	1.050 (26.7)	1.531 (38.9)	1.375 (34.9)
04	1	1.041 (26.4)	1.066 (27.1)	1.290 (32.8)	1.315 (33.4)	1.781 (45.2)	1.625 (41.3)
05	1 1/4	1.380 (35.1)	1.410 (35.8)	1.630 (41.4)	1.660 (42.2)	2.218 (56.3)	2.062 (52.4)
06	1 1/2	1.575 (40.0)	1.600 (40.6)	1.875 (47.6)	1.900 (48.3)	2.468 (62.7)	2.312 (58.7)
07	2	2.020 (51.3)	2.045 (51.9)	2.350 (59.7)	2.375 (60.3)	3.031 (77.0)	2.875 (73.0)