

54AC04 Hex Inverter

General Description

The AC04 contains six inverters.

Features

- I_{CC} reduced by 50% on 54AC only
- Outputs source/sink 24 mA
- 'ACT04 has TTL-compatible inputs
- Standard Military Drawing (SMD)
 - 'AC04: 5962-87609
- For Military 54ACT04 device see 54ACTQ04

Logic Symbol

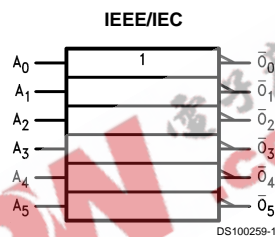

Connection Diagrams

Pin Assignment
for DIP and Flatpak

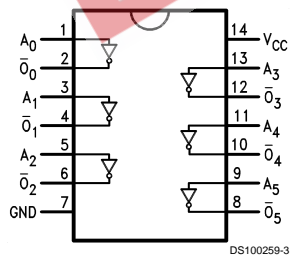

Pin Assignment
for LCC

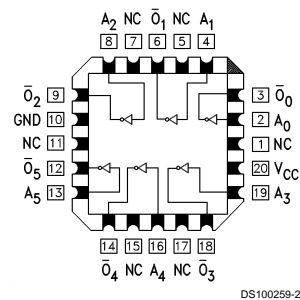

Pin Names	Description
A_n	Inputs
\bar{O}_n	Outputs

Absolute Maximum Ratings (Note 1)

If Military/Aerospace specified devices are required, please contact the National Semiconductor Sales Office/Distributors for availability and specifications.

Supply Voltage (V_{CC})	-0.5V to +7.0V
DC Input Diode Current (I_{IK})	
$V_I = -0.5V$	-20 mA
$V_I = V_{CC} + 0.5V$	+20 mA
DC Input Voltage (V_I)	-0.5V to $V_{CC} + 0.5V$
DC Output Diode Current (I_{OK})	
$V_O = -0.5V$	-20 mA
$V_O = V_{CC} + 0.5V$	+20 mA
DC Output Voltage (V_O)	-0.5V to $V_{CC} + 0.5V$
DC Output Source	
or Sink Current (I_O)	± 50 mA
DC V_{CC} or Ground Current	
per Output Pin (I_{CC} or I_{GND})	± 50 mA

Storage Temperature (T_{STG})	-65°C to +150°C
Junction Temperature (T_J)	
CDIP	175°C

Recommended Operating Conditions

Supply Voltage (V_{CC})		
'AC	2.0V to 6.0V	
Input Voltage (V_I)	0V to V_{CC}	
Output Voltage (V_O)	0V to V_{CC}	
Operating Temperature (T_A)		
54AC	-55°C to +125°C	
Minimum Input Edge Rate ($\Delta V/\Delta t$)		
'AC Devices		
V_{IN} from 30% to 70% of V_{CC}		
V_{CC} @ 3.3V, 4.5V, 5.5V	125 mV/ns	

Note 1: Absolute maximum ratings are those values beyond which damage to the device may occur. The databook specifications should be met, without exception, to ensure that the system design is reliable over its power supply, temperature, and output/input loading variables. National does not recommend operation of FACT® circuits outside databook specifications.

DC Characteristics for 'AC Family Devices

Symbol	Parameter	V_{CC} (V)	54AC		Units	Conditions
			$T_A = -55^\circ\text{C to } +125^\circ\text{C}$			
			Guaranteed Limits			
V_{IH}	Minimum High Level Input Voltage	3.0	2.1	V	V _{OUT} = 0.1V or $V_{CC} - 0.1V$	
		4.5	3.15			
		5.5	3.85			
V_{IL}	Maximum Low Level Input Voltage	3.0	0.9	V	V _{OUT} = 0.1V or $V_{CC} - 0.1V$	
		4.5	1.35			
		5.5	1.65			
V_{OH}	Minimum High Level Output Voltage	3.0	2.9	V	I _{OUT} = -50 μ A	
		4.5	4.4			
		5.5	5.4			
		3.0	2.4	V	(Note 2) $V_{IN} = V_{IL}$ or V_{IH} -12 mA I _{OH} -24 mA -24 mA	
		4.5	3.7			
	5.5	4.7				
V_{OL}	Maximum Low Level Output Voltage	3.0	0.1	V	I _{OUT} = 50 μ A	
		4.5	0.1			
		5.5	0.1			
		3.0	0.5	V	(Note 2) $V_{IN} = V_{IL}$ or V_{IH} 12 mA I _{OL} 24 mA 24 mA	
		4.5	0.5			
	5.5	0.5				
I_{IN}	Maximum Input Leakage Current	5.5	± 1.0	μ A	$V_I = V_{CC}, GND$	
I_{OLD}	(Note 3) Minimum Dynamic Output Current	5.5	50	mA	V _{OLD} = 1.65V Max	
I_{OHD}		5.5	-50	mA	V _{OHD} = 3.85V Min	
I_{CC}	Maximum Quiescent Supply Current	5.5	40.0	μ A	$V_{IN} = V_{CC}$ or GND	

Note 2: All outputs loaded; thresholds on input associated with output under test.

Note 3: Maximum test duration 2.0 ms, one output loaded at a time.

DC Characteristics for 'AC Family Devices (Continued)

Note 4: I_{IN} and I_{CC} @ 3.0V are guaranteed to be less than or equal to the respective limit @ 5.5V V_{CC} .
 I_{CC} for 54AC @ 25°C is identical to 74AC @ 25°C.

AC Electrical Characteristics

Symbol	Parameter	V_{CC} (V) (Note 5)	54AC		Units	Fig. No.
			$T_A = -55^\circ\text{C}$ to $+125^\circ\text{C}$ $C_L = 50\text{ pF}$			
			Min	Max		
t_{PLH}	Propagation Delay	3.3	1.0	11.0	ns	
		5.0	1.5	8.5		
t_{PHL}	Propagation Delay	3.3	1.0	10.0	ns	
		5.0	1.5	7.5		

Note 5: Voltage Range 3.3 is 3.3V ± 0.3 V
Voltage Range 5.0 is 5.0V ± 0.5 V

Capacitance

Symbol	Parameter	Typ	Units	Conditions
C_{IN}	Input Capacitance	4.5	pF	$V_{CC} = \text{Open}$
C_{PD}	Power Dissipation Capacitance	30.0	pF	$V_{CC} = 5.0\text{V}$

EEPW 电子产品世界
.com.cn

Physical Dimensions inches (millimeters) unless otherwise noted

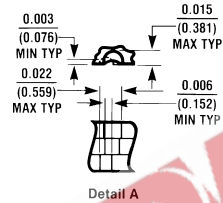
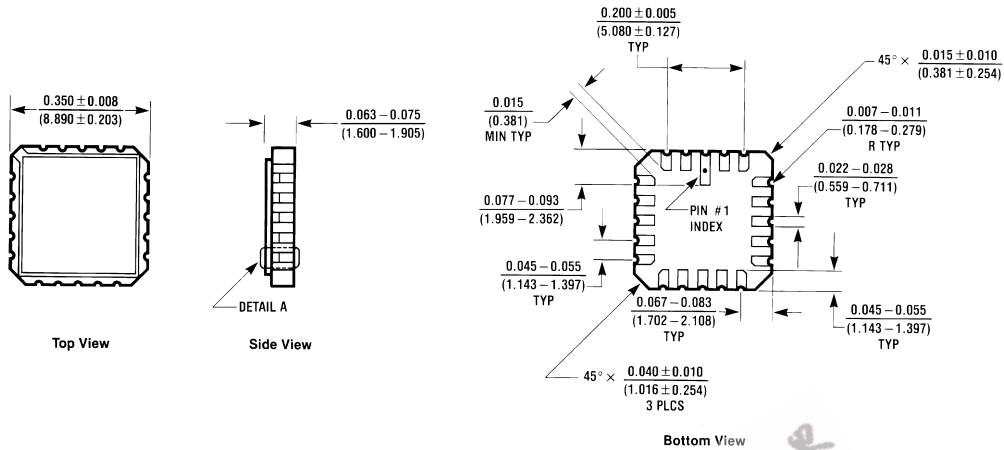

20 Terminal Ceramic Leadless Chip Carrier (L)
 NS Package Number E20A

E20A (REV. D)

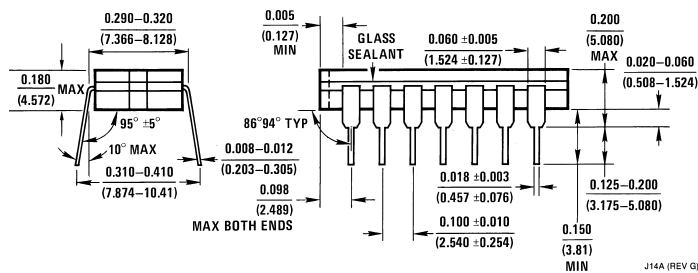
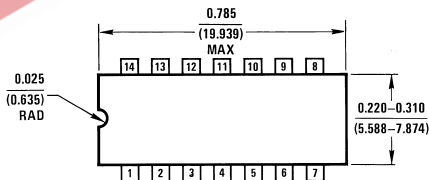

14 Lead Ceramic Dual-In-Line Package (D)
 NS Package Number J14A

Physical Dimensions inches (millimeters) unless otherwise noted (Continued)

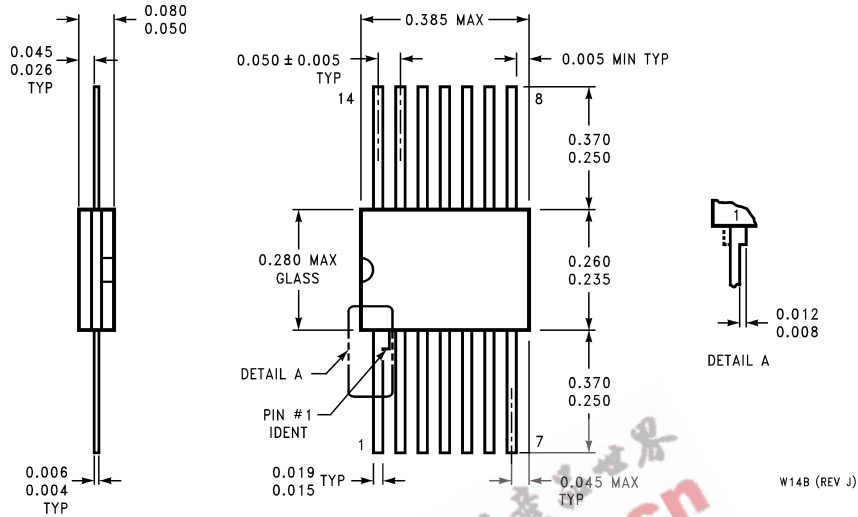

14 Lead Ceramic Flatpak (F)
NS Package Number W14B

EEPW.com.cn

LIFE SUPPORT POLICY

NATIONAL'S PRODUCTS ARE NOT AUTHORIZED FOR USE AS CRITICAL COMPONENTS IN LIFE SUPPORT DEVICES OR SYSTEMS WITHOUT THE EXPRESS WRITTEN APPROVAL OF THE PRESIDENT OF NATIONAL SEMICONDUCTOR CORPORATION. As used herein:

1. Life support devices or systems are devices or systems which, (a) are intended for surgical implant into the body, or (b) support or sustain life, and whose failure to perform when properly used in accordance with instructions for use provided in the labeling, can be reasonably expected to result in a significant injury to the user.
2. A critical component in any component of a life support device or system whose failure to perform can be reasonably expected to cause the failure of the life support device or system, or to affect its safety or effectiveness.



National Semiconductor Corporation
Americas
Tel: 1-800-272-9959
Fax: 1-800-737-7018
Email: support@nsc.com

National Semiconductor Europe
Fax: +49 (0) 1 80-530 85 86
Email: europe.support@nsc.com
Deutsch Tel: +49 (0) 1 80-530 85 85
English Tel: +49 (0) 1 80-532 78 32
Français Tel: +49 (0) 1 80-532 93 58
Italiano Tel: +49 (0) 1 80-534 16 80

National Semiconductor Asia Pacific Customer Response Group
Tel: 65-2544466
Fax: 65-2504466
Email: sea.support@nsc.com

National Semiconductor Japan Ltd.
Tel: 81-3-5620-6175
Fax: 81-3-5620-6179

www.national.com