

54ACTQ16646 16-Bit Transceiver/Register with TRI-STATE® Outputs

General Description

The 'ACTQ16646 contains sixteen non-inverting bidirectional registered bus transceivers providing multiplexed transmission of data directly from the input bus or from the internal storage registers. Each byte has separate control inputs which can be shorted together for full 16-bit operation. The DIR inputs determine the direction of data flow through the device. The CPAB and CPBA inputs load data into the registers on the LOW-to-HIGH transition. The 'ACTQ16646 utilizes NSC Quiet Series technology to guarantee quiet output switching and improved dynamic threshold performance. FACT Quiet Series® features GTO® output control and undershoot corrector for superior performance.

Features

- Utilizes NSC FACT Quiet Series technology
- Guaranteed simultaneous switching noise level and dynamic threshold performance
- Independent registers for A and B buses
- Multiplexed real-time and stored data transfers
- Separate control logic for each byte
- 16-bit version of the 'ACTQ646
- Outputs source/sink 24 mA
- Standard Microcircuit Drawing (SMD) 5962-9581601

Logic Symbol

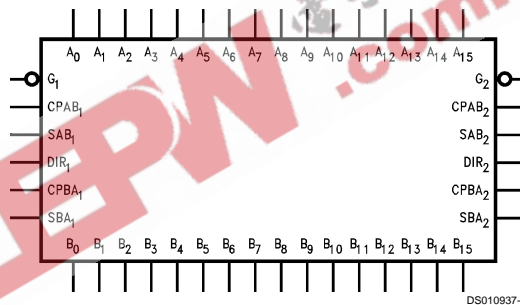

GTO™ is a trademark of National Semiconductor Corporation.
TRI-STATE® is a registered trademark of National Semiconductor Corporation.
FACT™ and FACT Quiet Series™ are trademarks of Fairchild Semiconductor Corporation.

Connection Diagram

Pin Assignment for CERPAK

DIR ₁	1	56	\bar{G}_1
CPAB ₁	2	55	CPBA ₁
SAB ₁	3	54	SBA ₁
GND	4	53	GND
A ₀	5	52	B ₀
A ₁	6	51	B ₁
V _{CC}	7	50	V _{CC}
A ₂	8	49	B ₂
A ₃	9	48	B ₃
A ₄	10	47	B ₄
GND	11	46	GND
A ₅	12	45	B ₅
A ₆	13	44	B ₆
A ₇	14	43	B ₇
A ₈	15	42	B ₈
A ₉	16	41	B ₉
A ₁₀	17	40	B ₁₀
GND	18	39	GND
A ₁₁	19	38	B ₁₁
A ₁₂	20	37	B ₁₂
A ₁₃	21	36	B ₁₃
V _{CC}	22	35	V _{CC}
A ₁₄	23	34	B ₁₄
A ₁₅	24	33	B ₁₅
GND	25	32	GND
SAB ₂	26	31	SBA ₂
CPAB ₂	27	30	CPBA ₂
DIR ₂	28	29	\bar{G}_2

DS010937-2

Real Time Transfer A-Bus to B-Bus

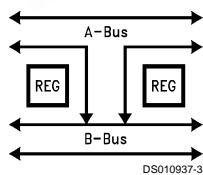

DS010937-3

FIGURE 1.

Storage from Bus to Register

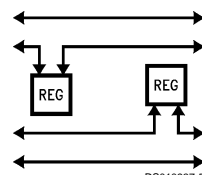

DS010937-5

FIGURE 3.

Real Time Transfer B-Bus to A-Bus

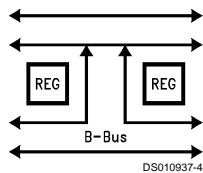

DS010937-4

FIGURE 2.

Transfer from Register to Bus

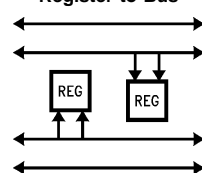

DS010937-6

FIGURE 4.

Function Table

Inputs						Data I/O (Note 1)		Output Operation Mode
G ₁	DIR ₁	CPAB ₁	CPBA ₁	SAB ₁	SBA ₁	A ₀₋₇	B ₀₋₇	
H	X	H or L	H or L	X	X	Input	Input	Isolation
H	X	N	X	X	X			Clock An Data into A Register
H	X	X	N	X	X			Clock Bn Data Into B Register
L	H	X	X	L	X	Input	Output	An to Bn— Real Time (Transparent Mode)
L	H	N	X	L	X			Clock An Data to A Register
L	H	H or L	X	H	X			A Register to Bn (Stored Mode)
L	H	N	X	H	X			Clock An Data into A Register and Output to Bn
L	L	X	X	X	L	Output	Input	Bn to An— Real Time (Transparent Mode)
L	L	X	N	X	L			Clock Bn Data into B Register
L	L	X	H or L	X	H			B Register to An (Stored Mode)
L	L	X	N	X	H			Clock Bn into B Register and Output to An

H = HIGH Voltage Level X = Immaterial

L = LOW Voltage Level N = LOW-to-HIGH Transition.

Note 1: The data output functions may be enabled or disabled by various signals at the G and DIR inputs. Data input functions are always enabled; i.e., data at the bus pins will be stored on every LOW-to-HIGH transition of the appropriate clock inputs. Also applies to data I/O (A and B: 8-15) and #2 control pins.

EEPW.com.cn 电子產品世界

Logic Diagram

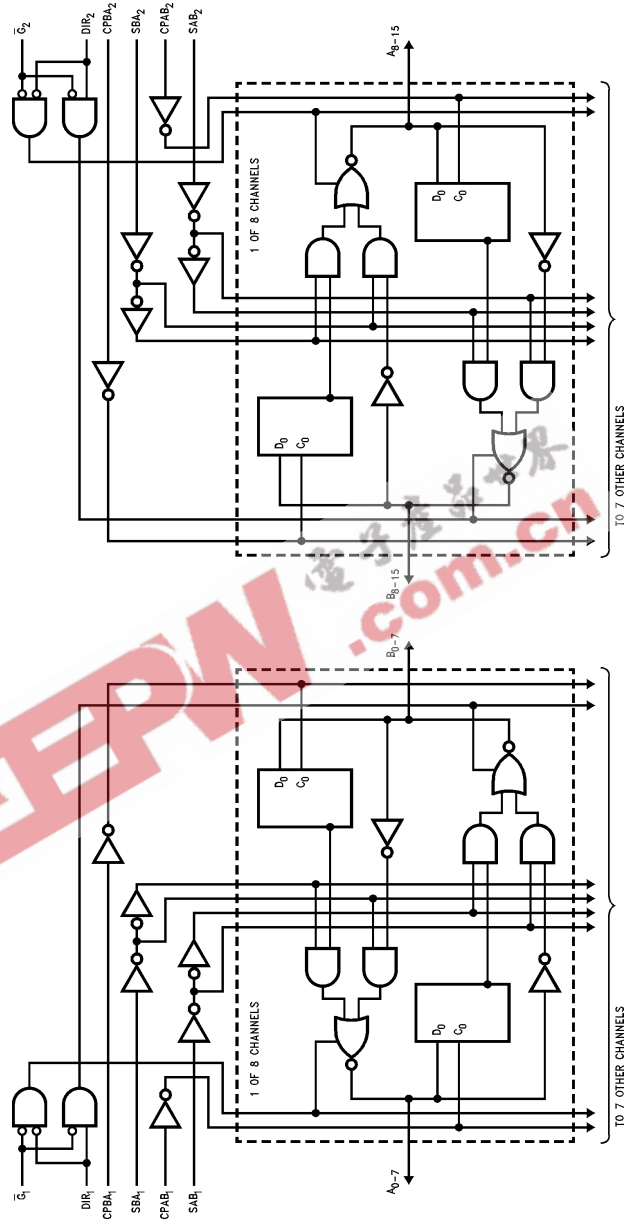

Absolute Maximum Ratings (Note 2)

If Military/Aerospace specified devices are required, please contact the National Semiconductor Sales Office/Distributors for availability and specifications.

Supply Voltage (V_{CC})	-0.5V to +7.0V
DC Input Diode Current (I_{IK})	
$V_I = -0.5V$	-20 mA
$V_I = V_{CC} + 0.5V$	+20 mA
DC Output Diode Current (I_{OK})	
$V_O = -0.5V$	-20 mA
$V_O = V_{CC} + 0.5V$	+20 mA
DC Output Voltage (V_O)	-0.5V to $V_{CC} + 0.5V$
DC Output Source/Sink Current (I_O)	±50 mA
DC V_{CC} or Ground Current per Output Pin	±50 mA
Junction Temperature	
CDIP	+175°C
Storage Temperature	-65°C to +150°C

Recommended Operating Conditions

Supply Voltage (V_{CC})	
'ACTQ	4.5V to 5.5V
Input Voltage (V_I)	0V to V_{CC}
Output Voltage (V_O)	0V to V_{CC}
Operating Temperature (T_A):	
54ACTQ	-55°C to +125°C
Minimum Input Edge Rate (dV/dt)	
'ACTQ Devices	125 mV/ns
V_{IN} from 0.8V to 2.0V	
V_{CC} @ 4.5V, 5.5V	

Note 2: Absolute maximum ratings are those values beyond which damage to the device may occur. The databook specifications should be met, without exception to ensure that the system design is reliable over its power supply, temperature, and output/input loading variables. National does not recommend operation of FACT™ circuits outside databook specifications.

DC Electrical Characteristics for 'ACTQ Family Devices

Symbol	Parameter	V_{CC} (V)	54ACTQ		Units	Conditions
			$T_A = -55^\circ\text{C to } +125^\circ\text{C}$			
			Guaranteed Limits			
V_{IH}	Minimum High Input Voltage	4.5	2.0	V	$V_{OUT} = 0.1V$ or $V_{CC} - 0.1V$	
		5.5	2.0			
V_{IL}	Maximum Low Input Voltage	4.5	0.8	V	$V_{OUT} = 0.1V$ or $V_{CC} - 0.1V$	
		5.5	0.8			
V_{OH}	Minimum High Output Voltage	4.5	4.4	V	$I_{OUT} = -50 \mu A$	
		5.5	5.4			
V_{OL}	Maximum Low Output Voltage	4.5	3.70	V	$V_{IN} = V_{IL}$ or V_{IH} $I_{OH} = -24 \text{ mA}$ $I_{OH} = -24 \text{ mA}$	
		5.5	4.70			
		4.5	0.1	V		
		5.5	0.1			
I_{OZT}	Maximum I/O Leakage Current	5.5	±10.0	μA	$V_{IN} = V_{IL}, V_{IH}$ $V_O = V_{CC}, \text{GND}$	
I_{IN}	Maximum Input Leakage Current	5.5	±1.0	μA	$V_I = V_{CC}, \text{GND}$	
I_{CCT}	Maximum I_{CC} /Input	5.5	1.6	mA	$V_I = V_{CC} - 2.1V$	
I_{CC}	Max Quiescent Supply Current	5.5	160.0	μA	$V_{IN} = V_{CC}$ or GND	
I_{OLD}	Minimum Dynamic	5.5	50	mA	$V_{OLD} = 1.65V \text{ Max}$	
I_{OHD}	Output Current (Note 4)		50	mA	$V_{OHD} = 3.85V \text{ Min}$	
V_{OLP}	Quick Output Maximum Dynamic V_{OL}	5.0	1.1	V	(Notes 5, 6)	
V_{OLV}	Quick Output Minimum Dynamic V_{OL}	5.0	-0.8	V	(Notes 5, 6)	

Note 3: All outputs loaded; thresholds associated with output under test.

Note 4: Maximum test duration 2.0 ms; one output loaded at a time.

Note 5: Maximum number of outputs that can switch simultaneously is n. (n - 1) outputs are switched LOW and one output held LOW.

DC Electrical Characteristics for 'ACTQ Family Devices (Continued)

Note 6: Maximum number of outputs that can switch simultaneously is n. (n - 1) outputs are switched HIGH and one output held HIGH.

AC Electrical Characteristics

Symbol	Parameter	V _{CC} (V) (Note 7)	54ACTQ		Units
			T _A = -55°C to +125°C C _L = 50 pF		
			Min	Max	
t _{PHL} t _{PLH}	Propagation Delay Clock to Bus	5.0	2.9 3.2	10.2 10.2	ns
t _{PHL} t _{PLH}	Propagation Delay Bus to Bus	5.0	3.6 3.3	11.5 10.8	ns
t _{PHL} t _{PLH}	Propagation Delay Select to Bus (w/An or Bn HIGH or LOW)	5.0	3.1 3.2	11.3 11.5	ns
t _{PZL} t _{PZH}	Enable Time G to An/Bn	5.0	3.8 3.3	12.9 11.9	ns
t _{PLZ} t _{PHZ}	Disable Time G to An/Bn	5.0	2.3 2.6	9.8 9.5	ns
t _{PZL} t _{PZH}	Enable Time DIR to An/Bn	5.0	4.3 3.7	14.0 12.8	ns
t _{PLZ} t _{PHZ}	Disable Time DIR to An/Bn	5.0	2.0 2.5	10.8 11.0	ns

Note 7: Voltage Range 5.0 is 5.0V ±0.5V.

AC Operating Requirements

Symbol	Parameter	V _{CC} (V) (Note 8)	54ACTQ		Units
			T _A = -55°C to +125°C C _L = 50 pF		
			Guaranteed Minimum		
t _S	Setup Time, H or L Bus to Clock	5.0	3.0		ns
t _H	Hold Time, H or L Bus to Clock	5.0	1.5		ns
t _W	Clock Pulse Width H or L	5.0	4.0		ns

Note 8: Voltage Range 5.0 is 5.0V ±0.5V.

Capacitance

Symbol	Parameter	Typ	Units	Conditions
C _{IN}	Input Capacitance	4.5	pF	V _{CC} = 5.0V
C _{PD}	Power Dissipation Capacitance	95	pF	V _{CC} = 5.0V

EEPW 电子产品世界
.com.cn

Physical Dimensions inches (millimeters) unless otherwise noted

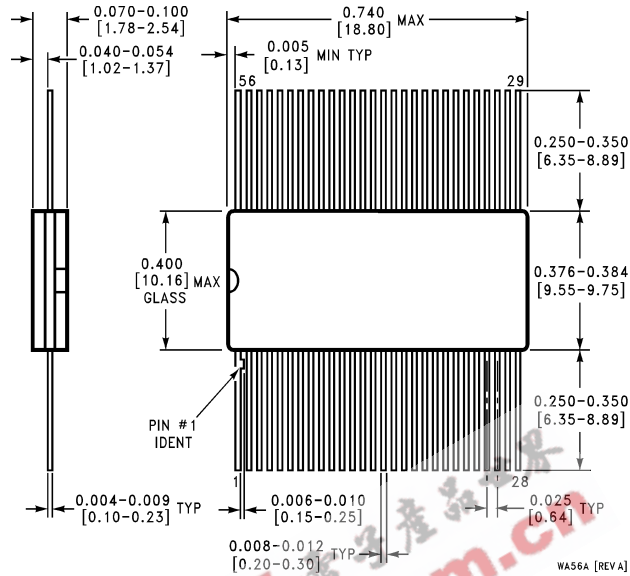

LIFE SUPPORT POLICY

NATIONAL'S PRODUCTS ARE NOT AUTHORIZED FOR USE AS CRITICAL COMPONENTS IN LIFE SUPPORT DEVICES OR SYSTEMS WITHOUT THE EXPRESS WRITTEN APPROVAL OF THE PRESIDENT OF NATIONAL SEMICONDUCTOR CORPORATION. As used herein:

1. Life support devices or systems are devices or systems which, (a) are intended for surgical implant into the body, or (b) support or sustain life, and whose failure to perform when properly used in accordance with instructions for use provided in the labeling, can be reasonably expected to result in a significant injury to the user.
2. A critical component in any component of a life support device or system whose failure to perform can be reasonably expected to cause the failure of the life support device or system, or to affect its safety or effectiveness.



National Semiconductor Corporation
Americas
Tel: 1-800-272-9959
Fax: 1-800-737-7018
Email: support@nsc.com

National Semiconductor Europe
Fax: +49 (0) 1 80-530 85 86
Email: europe.support@nsc.com
Deutsch Tel: +49 (0) 1 80-530 85 85
English Tel: +49 (0) 1 80-532 78 32
Français Tel: +49 (0) 1 80-532 93 58
Italiano Tel: +49 (0) 1 80-534 16 80

National Semiconductor Asia Pacific Customer Response Group
Tel: 65-2544466
Fax: 65-2504466
Email: sea.support@nsc.com

National Semiconductor Japan Ltd.
Tel: 81-3-5620-6175
Fax: 81-3-5620-6179

www.national.com