

SN5454, SN54LS54, SN7454, SN74LS54 4-WIDE AND-OR-INVERT GATES

SDLS115

DECEMBER 1983—REVISED MARCH 1988

- Package Options Include Plastic "Small Outline" Packages, Ceramic Chip Carriers and Flat Packages, and Plastic and Ceramic DIPs
- Dependable Texas Instruments Quality and Reliability

description

These devices contain 4-wide AND-OR-INVERT gates. They perform the following Boolean functions:

$$\begin{aligned} \text{'54 } Y &= \overline{AB + CD + EF + GH} \\ \text{LS54 } Y &= \overline{AB + CDE + FGH + IJ} \end{aligned}$$

The SN5454 and SN54LS54 are characterized for operation over the full military temperature range of -55°C to 125°C . The SN7454 and SN74LS54 are characterized for operation from 0°C to 70°C .

logic diagrams (positive logic)

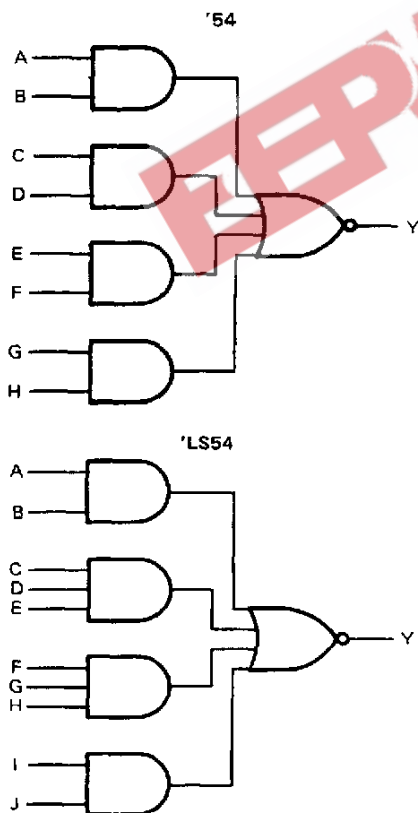

SN5454 . . . J PACKAGE
SN7454 . . . N PACKAGE
(TOP VIEW)

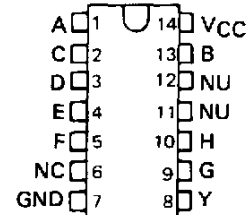

SN5454 . . . W PACKAGE
(TOP VIEW)

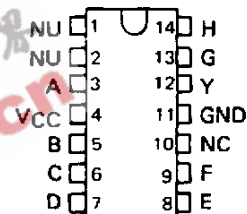

SN54LS54 . . . J OR W PACKAGE
SN74LS54 . . . D OR N PACKAGE
(TOP VIEW)

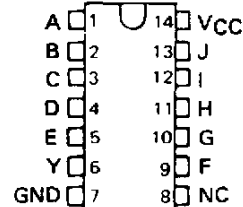

SN54LS54 . . . FK PACKAGE
(TOP VIEW)

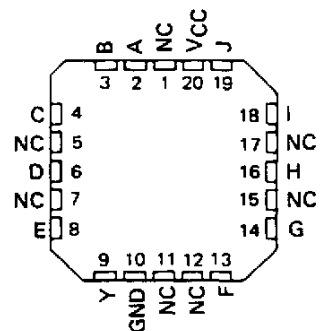

NC—No internal connection
NU—Make no external connection

PRODUCTION DATA documents contain information current as of publication date. Products conform to specifications per the terms of Texas Instruments standard warranty. Production processing does not necessarily include testing of all parameters.

TEXAS
INSTRUMENTS

POST OFFICE BOX 655012 • DALLAS, TEXAS 75265

SN5454, SN54LS54, SN7454, SN74LS54 4-WIDE AND-OR-INVERT GATES

logic symbols†

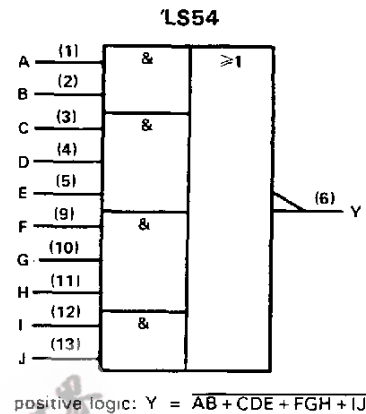
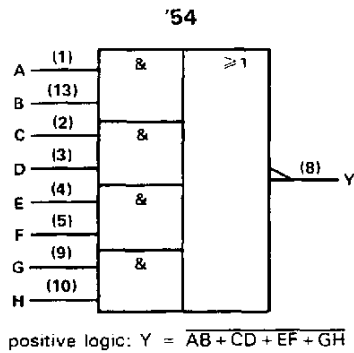

†These symbols are in accordance with ANSI/IEEE Std 91-1984 and IEC Publication 617-12. Pin numbers shown are for D, J, and N package. For the SN54LS54 only, they apply also for the W package.

schematics

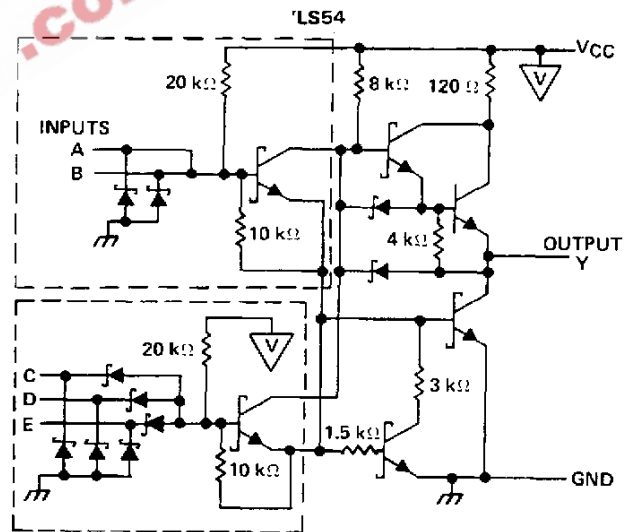
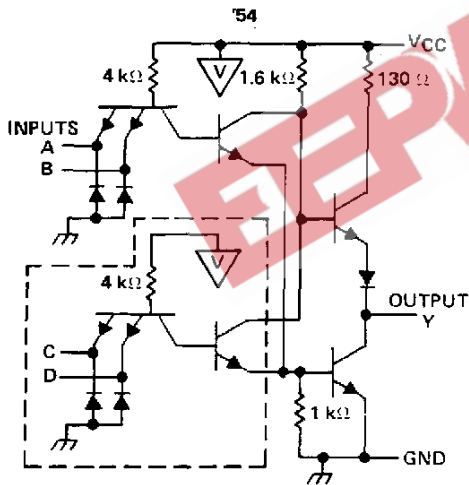

Resistor values shown are nominal.

The portion of the circuits within the dashed lines is repeated for each additional 2- or 3-input AND section, as shown in the logic diagram and logic symbols.

SN5454, SN7454 4-WIDE AND-OR-INVERT GATES

absolute maximum ratings over operating free-air temperature range (unless otherwise noted)

Supply voltage, V_{CC} (see Note 1)	7 V
Input voltage	5.5 V
Operating free-air temperature: SN5454	-55°C to 125°C
SN7454	0°C to 70°C
Storage temperature range	-65°C to 150°C

NOTE 1: Voltage values are with respect to network ground terminal.

recommended operating conditions

	SN5454			SN7454			UNIT
	MIN	NOM	MAX	MIN	NOM	MAX	
V_{CC} Supply voltage	4.5	5	5.5	4.75	5	5.25	V
V_{IH} High-level input voltage	2			2			V
V_{IL} Low-level input voltage	0.8			0.8			V
I_{OH} High-level output current	-0.4			-0.4			mA
I_{OL} Low-level output current	16			16			mA
T_A Operating free-air temperature	-55	125		0	70		°C

electrical characteristics over recommended operating free-air temperature range (unless otherwise noted)

PARAMETER	TEST CONDITIONS†	SN5454			SN7454			UNIT
		MIN	TYP‡	MAX	MIN	TYP‡	MAX	
V_{IK}	$V_{CC} = \text{MIN.}$, $I_I = -12 \text{ mA}$	-1.5			-1.5			V
V_{OH}	$V_{CC} = \text{MIN.}$, $V_{IL} = 0.8 \text{ V.}$, $I_{OH} = -0.4 \text{ mA}$	2.4	3.4		2.4	3.4	V	
V_{OL}	$V_{CC} = \text{MIN.}$, $V_{IH} = 2 \text{ V.}$, $I_{OL} = 16 \text{ mA}$	0.2	0.4		0.2	0.4	V	
I_I	$V_{CC} = \text{MAX.}$, $V_I = 5.5 \text{ V}$	1			1			mA
I_{IH}	$V_{CC} = \text{MAX.}$, $V_I = 2.4 \text{ V}$	40			40			μA
I_{IL}	$V_{CC} = \text{MAX.}$, $V_I = 0.4 \text{ V}$	-1.6			-1.6			mA
$I_{OS}§$	$V_{CC} = \text{MAX.}$	-20		-55	-18		-55	mA
I_{CCH}	$V_{CC} = \text{MAX.}$, $V_I = 0 \text{ V}$	4	8		4	8	mA	
I_{CCL}	$V_{CC} = \text{MAX.}$, See Note 2	5.1	9.5		5.1	9.5	mA	

† For conditions shown as MIN or MAX, use the appropriate value specified under recommended operating conditions.

‡ All typical values are at $V_{CC} = 5 \text{ V}$, $T_A = 25^\circ\text{C}$.

§ Not more than one output should be shorted at a time.

NOTE 2: All inputs of one AND gate at 4.5 V, all others at GND.

switching characteristics, $V_{CC} = 5 \text{ V}$, $T_A = 25^\circ\text{C}$ (see note 3)

PARAMETER	FROM (INPUT)	TO (OUTPUT)	TEST CONDITIONS		MIN	TYP	MAX	UNIT
t_{PLH}	Any	Y	$R_L = 400 \Omega$,	$C_L = 15 \text{ pF}$	13	22		ns
t_{PHL}					8	15		ns

NOTE 3: Load circuits and voltage waveforms are shown in Section 1.

SN54LS54, SN74LS54 4-WIDE AND-OR-INVERT GATES

absolute maximum ratings over operating free-air temperature range (unless otherwise noted)

Supply voltage, V_{CC} (see Note 1)	7 V
Input voltage	7 V
Operating free-air temperature: SN54LS54	-55°C to 125°C
SN74LS54	0°C to 70°C
Storage temperature range	-65°C to 150°C

NOTE 1: Voltage values are with respect to network ground terminal.

recommended operating conditions

	SN54LS54			SN74LS54			UNIT
	MIN	NOM	MAX	MIN	NOM	MAX	
V_{CC} Supply voltage	4.5	5	5.5	4.75	5	5.25	V
V_{IH} High-level input voltage	2			2			V
V_{IL} Low-level input voltage			0.7			0.8	V
I_{OH} High-level output current			-0.4			-0.4	mA
I_{OL} Low-level output current			4			8	mA
T_A Operating free-air temperature	-55		125	0		70	°C

electrical characteristics over recommended operating free-air temperature range (unless otherwise noted)

PARAMETER	TEST CONDITIONS†	SN54LS54			SN74LS54			UNIT
		MIN	TYP‡	MAX	MIN	TYP‡	MAX	
V_{IK}	$V_{CC} = \text{MIN}$, $I_I = -18 \text{ mA}$			-1.5			-1.5	V
V_{OH}	$V_{CC} = \text{MIN}$, $V_{IL} = \text{MAX}$, $I_{OH} = -0.4 \text{ mA}$	2.5	3.4		2.7	3.4		V
V_{OL}	$V_{CC} = \text{MIN}$, $V_{IH} = 2 \text{ V}$, $I_{OL} = 4 \text{ mA}$		0.25	0.4		0.25	0.4	V
	$V_{CC} = \text{MIN}$, $V_{IH} = 2 \text{ V}$, $I_{OL} = 8 \text{ mA}$					0.35	0.5	
I_I	$V_{CC} = \text{MAX}$, $V_I = 7 \text{ V}$			0.1			0.1	mA
I_{IH}	$V_{CC} = \text{MAX}$, $V_I = 2.7 \text{ V}$			20			20	μA
I_{IL}	$V_{CC} = \text{MAX}$, $V_I = 0.4 \text{ V}$			-0.4			-0.4	mA
$I_{OS}§$	$V_{CC} = \text{MAX}$	-20		-100	-20		-100	mA
I_{CCH}	$V_{CC} = \text{MAX}$, $V_I = 0 \text{ V}$		0.8	1.6		0.8	1.6	mA
I_{CCL}	$V_{CC} = \text{MAX}$, See Note 2		1	2		1	2	mA

† For conditions shown as MIN or MAX, use the appropriate value specified under recommended operating conditions.

‡ All typical values are at $V_{CC} = 5 \text{ V}$, $T_A = 25^\circ \text{C}$.

§ Not more than one output should be shorted at a time, and the duration of the short-circuit should not exceed one second.

NOTE 2: All inputs of one AND gate at 4.5 V, all others at GND.

switching characteristics, $V_{CC} = 5 \text{ V}$, $T_A = 25^\circ \text{C}$ (see note 3)

PARAMETER	FROM (INPUT)	TO (OUTPUT)	TEST CONDITIONS	MIN	TYP	MAX	UNIT
t_{PLH}	Any	Y	$R_L = 2 \text{ k}\Omega$, $C_L = 15 \text{ pF}$		12	20	ns
t_{PHL}					12.5	20	ns

NOTE 3: Load circuits and voltage waveforms are shown in Section 1.

PACKAGING INFORMATION

Orderable Device	Status ⁽¹⁾	Package Type	Package Drawing	Pins	Package Qty	Eco Plan ⁽²⁾	Lead/Ball Finish	MSL Peak Temp ⁽³⁾
SN5454J	ACTIVE	CDIP	J	14	1	TBD	Call TI	Level-NC-NC-NC
SN54LS54J	ACTIVE	CDIP	J	14	1	TBD	Call TI	Level-NC-NC-NC
SN54LS54J	ACTIVE	CDIP	J	14	1	TBD	Call TI	Level-NC-NC-NC
SN7454N	OBSOLETE	PDIP	N	14		TBD	Call TI	Call TI
SN7454N	OBSOLETE	PDIP	N	14		TBD	Call TI	Call TI
SN74LS54D	OBSOLETE	SOIC	D	14		TBD	Call TI	Call TI
SN74LS54D	OBSOLETE	SOIC	D	14		TBD	Call TI	Call TI
SN74LS54DR	OBSOLETE	SOIC	D	14		TBD	Call TI	Call TI
SN74LS54DR	OBSOLETE	SOIC	D	14		TBD	Call TI	Call TI
SN74LS54J	OBSOLETE	CDIP	J	14		TBD	Call TI	Call TI
SN74LS54J	OBSOLETE	CDIP	J	14		TBD	Call TI	Call TI
SN74LS54N	OBSOLETE	PDIP	N	14		TBD	Call TI	Call TI
SN74LS54N	OBSOLETE	PDIP	N	14		TBD	Call TI	Call TI
SNJ5454J	ACTIVE	CDIP	J	14	1	TBD	Call TI	Level-NC-NC-NC
SNJ5454J	ACTIVE	CDIP	J	14	1	TBD	Call TI	Level-NC-NC-NC
SNJ5454W	ACTIVE	CFP	W	14	1	TBD	Call TI	Level-NC-NC-NC
SNJ5454W	ACTIVE	CFP	W	14	1	TBD	Call TI	Level-NC-NC-NC
SNJ54LS54FK	OBSOLETE			20		TBD	Call TI	Call TI
SNJ54LS54FK	OBSOLETE			20		TBD	Call TI	Call TI
SNJ54LS54J	ACTIVE	CDIP	J	14	1	TBD	Call TI	Level-NC-NC-NC
SNJ54LS54J	ACTIVE	CDIP	J	14	1	TBD	Call TI	Level-NC-NC-NC
SNJ54LS54W	ACTIVE	CFP	W	14	1	TBD	Call TI	Level-NC-NC-NC
SNJ54LS54W	ACTIVE	CFP	W	14	1	TBD	Call TI	Level-NC-NC-NC

⁽¹⁾ The marketing status values are defined as follows:

ACTIVE: Product device recommended for new designs.

LIFEBUY: TI has announced that the device will be discontinued, and a lifetime-buy period is in effect.

NRND: Not recommended for new designs. Device is in production to support existing customers, but TI does not recommend using this part in a new design.

PREVIEW: Device has been announced but is not in production. Samples may or may not be available.

OBSOLETE: TI has discontinued the production of the device.

⁽²⁾ Eco Plan - The planned eco-friendly classification: Pb-Free (RoHS) or Green (RoHS & no Sb/Br) - please check <http://www.ti.com/productcontent> for the latest availability information and additional product content details.

TBD: The Pb-Free/Green conversion plan has not been defined.

Pb-Free (RoHS): TI's terms "Lead-Free" or "Pb-Free" mean semiconductor products that are compatible with the current RoHS requirements for all 6 substances, including the requirement that lead not exceed 0.1% by weight in homogeneous materials. Where designed to be soldered at high temperatures, TI Pb-Free products are suitable for use in specified lead-free processes.

Green (RoHS & no Sb/Br): TI defines "Green" to mean Pb-Free (RoHS compatible), and free of Bromine (Br) and Antimony (Sb) based flame retardants (Br or Sb do not exceed 0.1% by weight in homogeneous material)

⁽³⁾ MSL, Peak Temp. -- The Moisture Sensitivity Level rating according to the JEDEC industry standard classifications, and peak solder temperature.

Important Information and Disclaimer: The information provided on this page represents TI's knowledge and belief as of the date that it is provided. TI bases its knowledge and belief on information provided by third parties, and makes no representation or warranty as to the accuracy of such information. Efforts are underway to better integrate information from third parties. TI has taken and continues to take reasonable steps to provide representative and accurate information but may not have conducted destructive testing or chemical analysis on incoming materials and chemicals. TI and TI suppliers consider certain information to be proprietary, and thus CAS numbers and other limited

information may not be available for release.

In no event shall TI's liability arising out of such information exceed the total purchase price of the TI part(s) at issue in this document sold by TI to Customer on an annual basis.

EEPW 电子產品世界
.com.cn

J (R-GDIP-T**)
14 LEADS SHOWN

CERAMIC DUAL IN-LINE PACKAGE

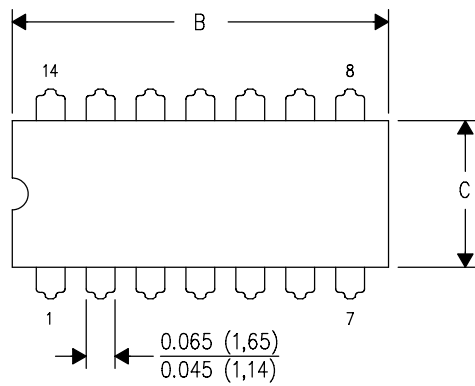

DIM \ PINS **	14	16	18	20
A	0.300 (7,62) BSC	0.300 (7,62) BSC	0.300 (7,62) BSC	0.300 (7,62) BSC
B MAX	0.785 (19,94)	.840 (21,34)	0.960 (24,38)	1.060 (26,92)
B MIN	—	—	—	—
C MAX	0.300 (7,62)	0.300 (7,62)	0.310 (7,87)	0.300 (7,62)
C MIN	0.245 (6,22)	0.245 (6,22)	0.220 (5,59)	0.245 (6,22)



4040083/F 03/03

- NOTES:
- All linear dimensions are in inches (millimeters).
 - This drawing is subject to change without notice.
 - This package is hermetically sealed with a ceramic lid using glass frit.
 - Index point is provided on cap for terminal identification only on press ceramic glass frit seal only.
 - Falls within MIL STD 1835 GDIP1-T14, GDIP1-T16, GDIP1-T18 and GDIP1-T20.

MECHANICAL DATA

W (R-GDFP-F14)

CERAMIC DUAL FLATPACK

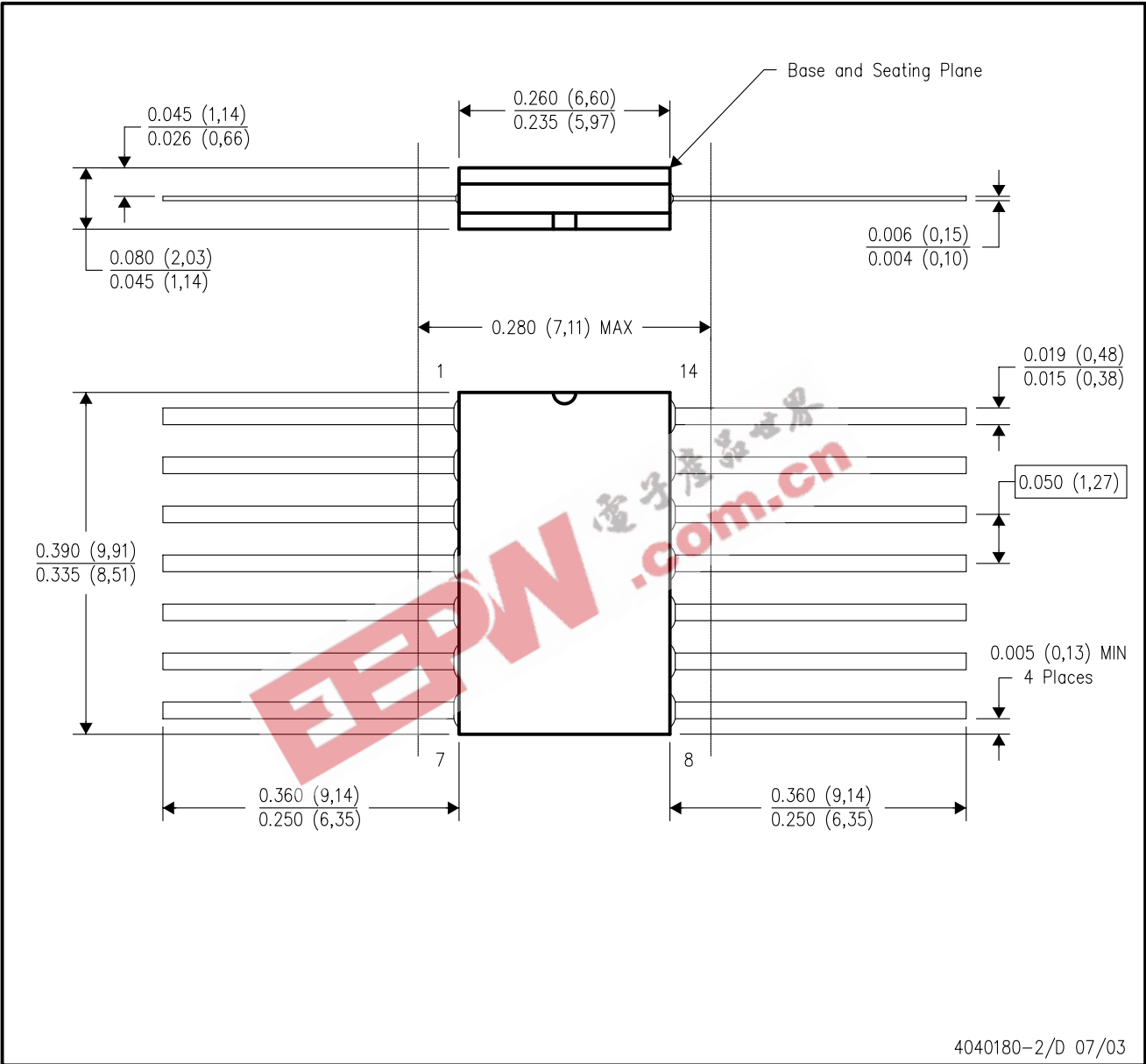

- NOTES:
- A. All linear dimensions are in inches (millimeters).
 - B. This drawing is subject to change without notice.
 - C. This package can be hermetically sealed with a ceramic lid using glass frit.
 - D. Index point is provided on cap for terminal identification only.
 - E. Falls within MIL STD 1835 GDFP1-F14 and JEDEC MO-092AB

MECHANICAL DATA

N (R-PDIP-T**)

PLASTIC DUAL-IN-LINE PACKAGE

16 PINS SHOWN

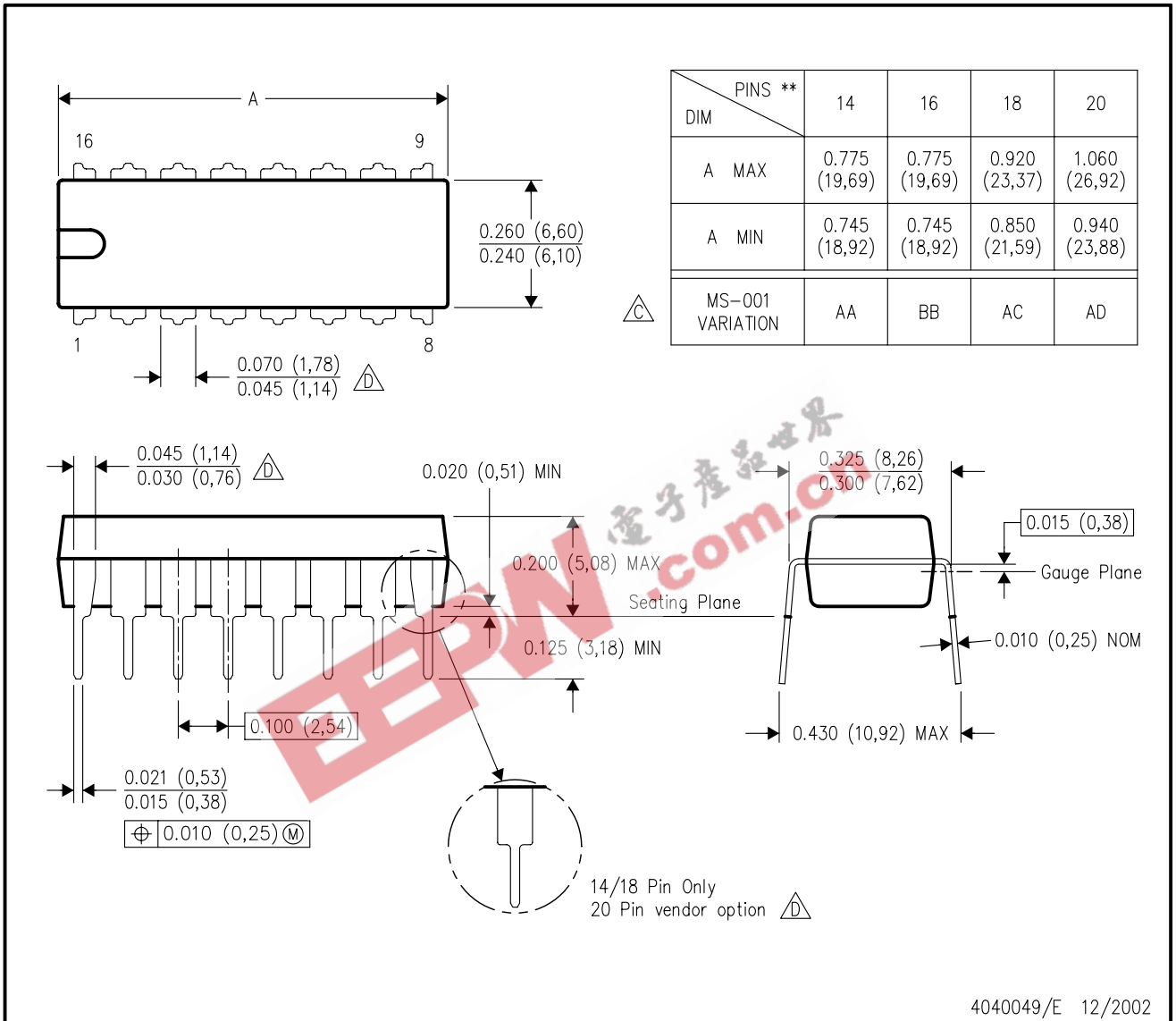

- NOTES: A. All linear dimensions are in inches (millimeters).
 B. This drawing is subject to change without notice.

- △ Falls within JEDEC MS-001, except 18 and 20 pin minimum body length (Dim A).
 △ The 20 pin end lead shoulder width is a vendor option, either half or full width.

MECHANICAL DATA

D (R-PDSO-G14)

PLASTIC SMALL-OUTLINE PACKAGE

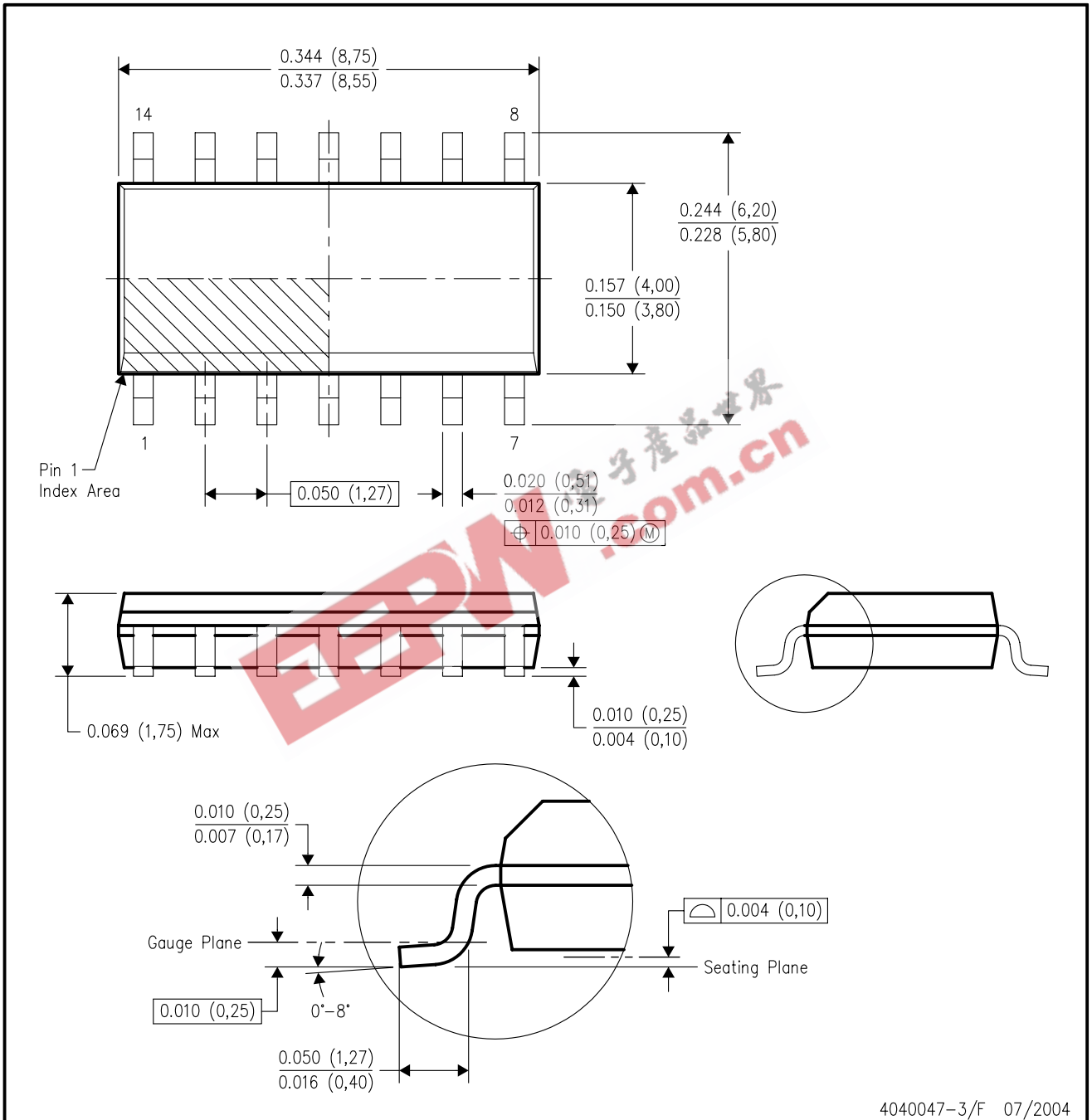

4040047-3/F 07/2004

- NOTES:
- All linear dimensions are in inches (millimeters).
 - This drawing is subject to change without notice.
 - Body dimensions do not include mold flash or protrusion not to exceed 0.006 (0,15).
 - Falls within JEDEC MS-012 variation AB.

IMPORTANT NOTICE

Texas Instruments Incorporated and its subsidiaries (TI) reserve the right to make corrections, modifications, enhancements, improvements, and other changes to its products and services at any time and to discontinue any product or service without notice. Customers should obtain the latest relevant information before placing orders and should verify that such information is current and complete. All products are sold subject to TI's terms and conditions of sale supplied at the time of order acknowledgment.

TI warrants performance of its hardware products to the specifications applicable at the time of sale in accordance with TI's standard warranty. Testing and other quality control techniques are used to the extent TI deems necessary to support this warranty. Except where mandated by government requirements, testing of all parameters of each product is not necessarily performed.

TI assumes no liability for applications assistance or customer product design. Customers are responsible for their products and applications using TI components. To minimize the risks associated with customer products and applications, customers should provide adequate design and operating safeguards.

TI does not warrant or represent that any license, either express or implied, is granted under any TI patent right, copyright, mask work right, or other TI intellectual property right relating to any combination, machine, or process in which TI products or services are used. Information published by TI regarding third-party products or services does not constitute a license from TI to use such products or services or a warranty or endorsement thereof. Use of such information may require a license from a third party under the patents or other intellectual property of the third party, or a license from TI under the patents or other intellectual property of TI.

Reproduction of information in TI data books or data sheets is permissible only if reproduction is without alteration and is accompanied by all associated warranties, conditions, limitations, and notices. Reproduction of this information with alteration is an unfair and deceptive business practice. TI is not responsible or liable for such altered documentation.

Resale of TI products or services with statements different from or beyond the parameters stated by TI for that product or service voids all express and any implied warranties for the associated TI product or service and is an unfair and deceptive business practice. TI is not responsible or liable for any such statements.

Following are URLs where you can obtain information on other Texas Instruments products and application solutions:

Products		Applications	
Amplifiers	amplifier.ti.com	Audio	www.ti.com/audio
Data Converters	dataconverter.ti.com	Automotive	www.ti.com/automotive
DSP	dsp.ti.com	Broadband	www.ti.com/broadband
Interface	interface.ti.com	Digital Control	www.ti.com/digitalcontrol
Logic	logic.ti.com	Military	www.ti.com/military
Power Mgmt	power.ti.com	Optical Networking	www.ti.com/opticalnetwork
Microcontrollers	microcontroller.ti.com	Security	www.ti.com/security
		Telephony	www.ti.com/telephony
		Video & Imaging	www.ti.com/video
		Wireless	www.ti.com/wireless

Mailing Address: Texas Instruments
Post Office Box 655303 Dallas, Texas 75265