

FEATURES

- DC - 500 MHz
- 1.7 dB Insertion Loss
- 38 mV Transients
- +18 dBm 0.1 dB Compression at 1 MHz
- TTL Control
- 24 Pin DIP
- See DAT58032 for 24 Pin Flatpack



MODEL NO.
DA0953

GaAs 5 Section Attenuator

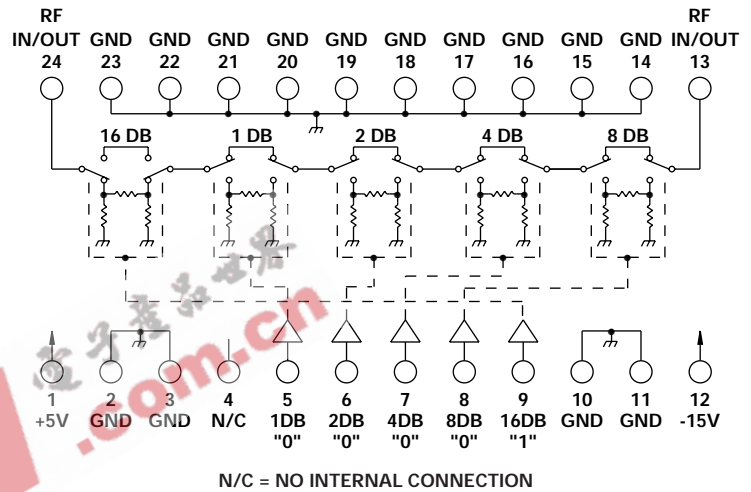
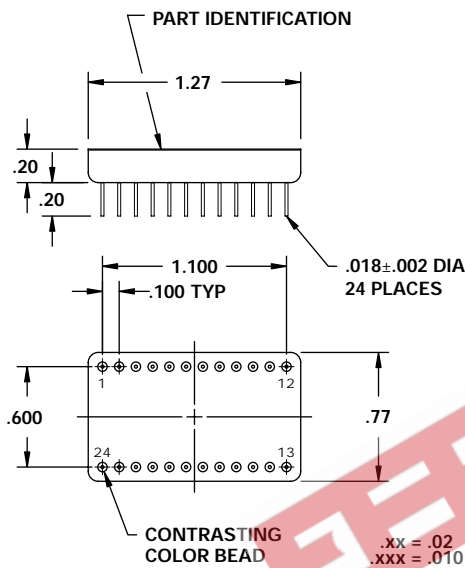

GUARANTEED PERFORMANCE

Parameter	Min	Typ	Max	Units	Conditions
Operating Frequency	DC		500	MHz	
DC Current		15 12	30 25	mA	At +5 VDC Supply At -15 VDC Supply
Control Type		TTL			5 Line Logic "0" = Thru Logic "1" = Attenuation
Control Current	High Low	0 0	±40 ±40	µA	V _{IH} = +2.7 V V _{IL} = +0.5 V
Insertion Loss		1.2 1.7	2.0 3.0	dB	DC - 100 MHz 100 - 500 MHz
Insertion Flatness		±0.02 ±0.15	±0.2 ±0.5	dB	5 - 15 MHz 0.1 - 60 MHz
Attenuation	LSB Range Accuracy	0	1 31	dB dB dB	1, 2, 4, 8, 16 ± (0.25 dB ± 2% of Atten. Setting in dB)
VSWR		1.1/1 1.4/1	1.3/1 1.6/1		DC - 100 MHz 100 - 500 MHz
Impedance		50		OHMS	
Switching Speed		100	200	nSec	50% TTL - 90% / 10% RF
Transition (Rise/Fall) Time		40		nSec	90% / 10% - 10% / 90% RF
Switching (Video) Transients		38	60	mV	Peak Value
Intercept Points	2nd 3rd	+76 +30	+45	dBm dBm	70 MHz / 50 MHz 35 MHz / 50 MHz
RF Power	Operate No Damage	+18	+13 +23	dBm dBm	0.1 dB Compression
Operating Temperature		-55	+25 +125	°C	TA

