



ST202EB - ST202EC ST232EB - ST232EC

± 15 kV ESD protected 5 V RS-232 transceiver

Features

- ESD protection for RS-232 I/O pins:
- ± 15 kV human body model
- Guaranteed 230 kbps data rate
- Guaranteed slew rate range 3 to 30 V/ms
- Operate from a single 5 V power supply

Description

The ST202E/ST232E are a 2 driver 2 receiver devices designed for RS-232 and V.28 communications in harsh environments. Each transmitter output and receiver input is protected against ± 15 kV electrostatic discharge (ESD) shocks. The drivers meet all EIA/TIA-232E and CCITT V.28 specifications at data rates up to 230 kbps, when loaded in accordance with the EIA/TIA-232E specification. The ST202E/232E use a single 5 V supply voltage.

The ST232E operates with four 1 µF capacitors, while the ST202E operates with four 0.1 µF capacitors, further reducing cost and board space.

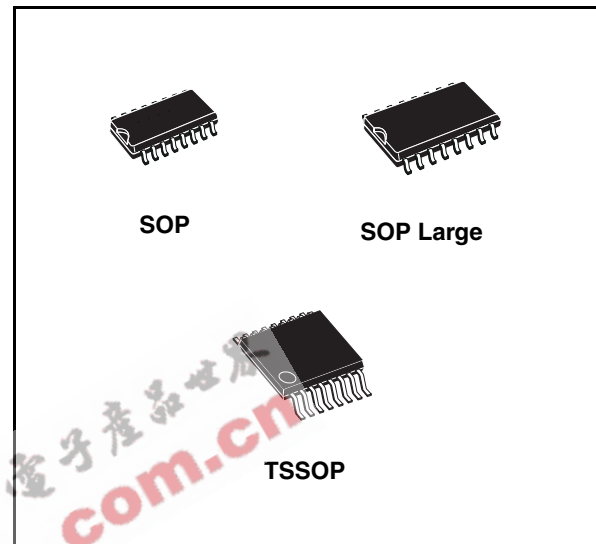

Table 1. Device summary

Order codes		Temperature range	Packages	Packaging
ST202ECDR	ST232ECDR	0 to 70 °C	SO-16 (tape & reel)	2500 parts per reel
ST202EBDR	ST232EBDR	-40 to 85 °C	SO-16 (tape & reel)	2500 parts per reel
	ST232ECWR	0 to 70 °C	SO-16 large (tape & reel)	1000 parts per reel
ST202EBWR		-40 to 85 °C	SO-16 large (tape & reel)	1000 parts per reel
ST202ECTR	ST232ECTR	0 to 70 °C	TSSOP16 (tape & reel)	2500 parts per reel
ST202EBTR	ST232EBTR	-40 to 85 °C	TSSOP16 (tape & reel)	2500 parts per reel

Contents

1	Pin configuration	3
2	Maximum ratings	4
3	Electrical characteristics	5
4	Typical application	7
5	Typical performance characteristics	8
6	Package mechanical data	10
7	Revision history	17

EEPW 电子产品世界
.com.cn

1 Pin configuration

Figure 1. Pin connections (top view)

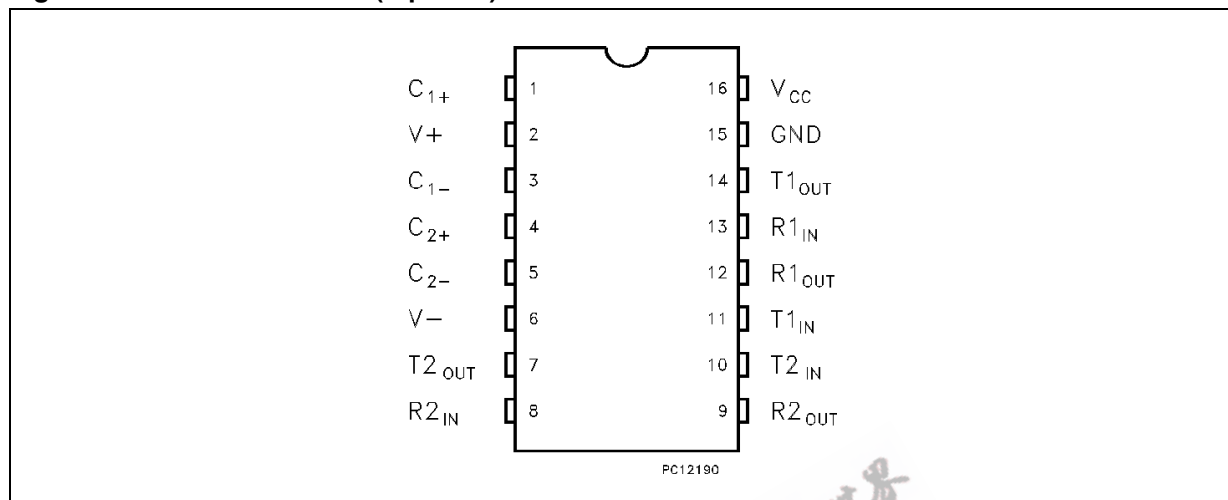

Table 2. Pin description

Pin n°	Symbol	Note
1	C ₁₊	Positive terminal for the first charge pump capacitor
2	V+	Doubled voltage terminal
3	C ₁₋	Negative terminal for the first charge pump capacitor
4	C ₂₊	Positive terminal for the second charge pump capacitor
5	C ₂₋	Negative terminal for the second charge pump capacitor
6	V-	Inverted voltage terminal
7	T ₂ OUT	Second transmitter output voltage
8	R ₂ IN	Second receiver input voltage
9	R ₂ OUT	Second receiver output voltage
10	T ₂ IN	Second transmitter input voltage
11	T ₁ IN	First transmitter input voltage
12	R ₁ OUT	First receiver output voltage
13	R ₁ IN	First receiver input voltage
14	T ₁ OUT	First transmitter output voltage
15	GND	Ground
16	V _{CC}	Supply voltage

2 Maximum ratings

Table 3. Absolute maximum ratings

Symbol	Parameter	Value	Unit
V_{CC}	Supply voltage	-0.3 to 6	V
V_+	Extra positive voltage	$(V_{CC} - 0.3)$ to 14	V
V_-	Extra negative voltage	-14 to 0.3	V
T_{IN}	Transmitter input voltage range	-0.3 to $(V_+ + 0.3)$	V
R_{IN}	Receiver input voltage range	± 30	V
T_{OUT}	Transmitter output voltage range	$(V_- - 0.3)$ to $(V_+ + 0.3)$	V
R_{OUT}	Receiver output voltage range	-0.3 to $(V_{CC} + 0.3)$	V
T_{SCTOUT}	Short circuit duration on T_{OUT}	infinite	
T_{STG}	Storage temperature range	-65 to 150	°C

Note: Absolute maximum ratings are those values beyond which damage to the device may occur. Functional operation under these condition is not implied.

3 Electrical characteristics

Table 4. ESD performance: transmitter outputs, receiver inputs

Symbol	Parameter	Test condition	Min.	Typ.	Max.	Unit
ESD	ESD protection voltage	Human Body Model	± 15			kV
ESD	ESD protection voltage	IEC 1000-4-2 (Contact Discharge)	± 6			kV
ESD	ESD protection voltage	IEC 1000-4-2 (Air Discharge)	± 8			kV

Note: All test versus GND.

Table 5. Electrical characteristics

($C_1 - C_4 = 0.1 \mu\text{F}$ for ST202E, $C_1 - C_4 = 0.1 \mu\text{F}$ for ST232E, $V_{\text{CC}} = 5 \text{ V} \pm 10 \%$, $T_A = -40$ to $125 \text{ }^\circ\text{C}$, unless otherwise specified. Typical values are referred to $T_A = 25 \text{ }^\circ\text{C}$).

Symbol	Parameter	Test condition	Min.	Typ.	Max.	Unit
I_{SUPPLY}	V_{CC} power supply current	No Load, $T_A = 25^\circ\text{C}$		5	10	mA

Table 6. Transmitter electrical characteristics

($C_1 - C_4 = 0.1 \mu\text{F}$, $V_{\text{CC}} = 5 \text{ V} \pm 10 \%$, $T_A = -40$ to $85 \text{ }^\circ\text{C}$, unless otherwise specified. Typical values are referred to $T_A = 25 \text{ }^\circ\text{C}$).

Symbol	Parameter	Test condition	Min.	Typ.	Max.	Unit
V_{TOUT}	Output voltage swing	All Transmitter outputs are loaded with $3 \text{ k}\Omega$ to GND	± 5	± 9		V
I_{TIL}	Input leakage current				± 10	μA
V_{TIL}	Input logic threshold low		0.8			V
V_{TIH}	Input logic threshold high				2	V
SR_T	Transition slew rate	$T_A = 25^\circ\text{C}$, $V_{\text{CC}} = 5 \text{ V}$ $R_L = 3$ to $7 \text{ k}\Omega$ $C_L = 50$ to 1000 pF (1)	3	6	30	$\text{V}/\mu\text{s}$
D_R	Data rate	$R_L = 3$ to $7 \text{ k}\Omega$ $C_L = 50$ to 1000 pF one transmitter switching	230	400		kbits/s
R_{TOUT}	Transmitter output resistance	$V_{\text{CC}} = V_+ = V_- = 0\text{V}$ $V_{\text{OUT}} = \pm 2 \text{ V}$	300			Ω
I_{SC}	Transmitter output short circuit current			±10	±60	mA
t_{DT}	Transmitter propagation delay	$R_L = 3$ to $7 \text{ k}\Omega$ $C_L = 50$ to 2500 pF All transmitter loaded		2		μs

1. Measured from 3 V to -3 V or from -3 V to 3 V

2. One transmitter output is loaded with $R_L = 3 \text{ k}\Omega$ to $7 \text{ k}\Omega$ $C_L = 50$ to 1000 pF

Table 7. Receiver electrical characteristics

($C_1 - C_4 = 0.1 \mu\text{F}$, $V_{\text{CC}} = 5 \text{ V} \pm 10 \%$, $T_A = -40$ to $85 \text{ }^\circ\text{C}$, unless otherwise specified. Typical values are referred to $T_A = 25 \text{ }^\circ\text{C}$).

Symbol	Parameter	Test condition	Min.	Typ.	Max.	Unit
V_{RIN}	Receiver input voltage operating range		-30		30	V
R_{RIN}	RS-232 input resistance	$T_A = 25^\circ\text{C}$, $V_{\text{CC}} = 5 \text{ V}$	3	5	7	$\text{k}\Omega$
V_{RIL}	RS-232 input logic threshold low	$T_A = 25^\circ\text{C}$, $V_{\text{CC}} = 5 \text{ V}$	0.8	1.2		V
V_{RIH}	RS-232 input logic threshold high	$T_A = 25^\circ\text{C}$, $V_{\text{CC}} = 5 \text{ V}$		1.7	2.4	V
V_{RIHYS}	RS-232 input hysteresis	$V_{\text{CC}} = 5 \text{ V}$	0.2	0.5	1	V
V_{ROL}	TTL/CMOS output voltage low	$I_{\text{OUT}} = 3.2 \text{ mA}$			0.4	V
V_{ROH}	TTL/CMOS output voltage high	$I_{\text{OUT}} = -1 \text{ mA}$	3.5	$V_{\text{CC}} - 0.4$		V
t_{DR}	Receiver propagation delay	$C_L = 150 \text{ pF}$		0.5	10	μs

EEPW.com.cn 电子产品世界

4 Typical application

Figure 2. Application circuit (1) (2)

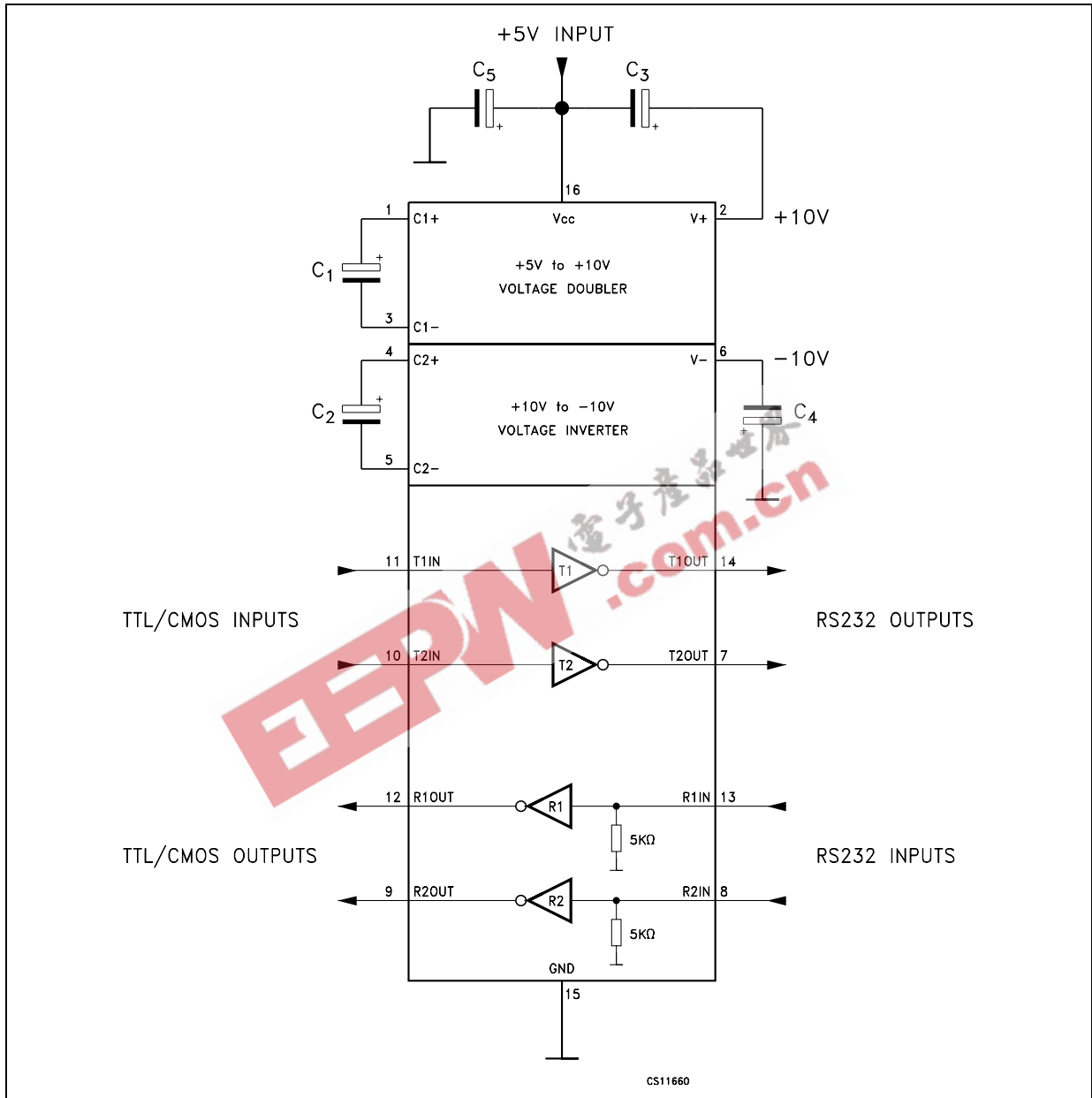

1. C₁₋₄ capacitors can even be 1μF ones
2. C₁₋₄ can be common or biased capacitors

Table 8. Capacitance value (μF)

Devices	C2	C3	C4	C5	C5
ST202E	0.1	0.1	0.1	0.1	0.1
ST232E	1	1	1	1	1

5 Typical performance characteristics

(Unless otherwise specified $T_J = 25\text{ }^\circ\text{C}$)

Figure 3. Supply current vs temperature

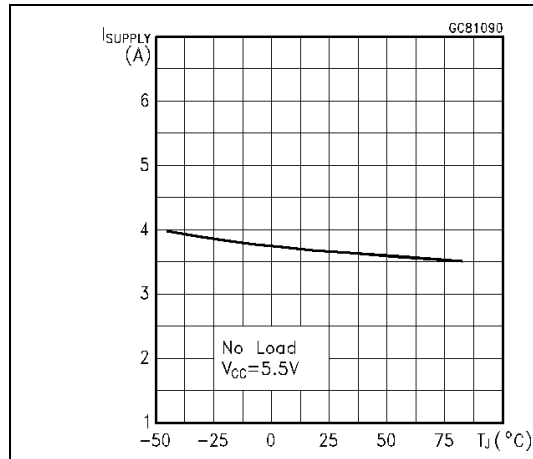

Figure 4. Data rate vs temperature

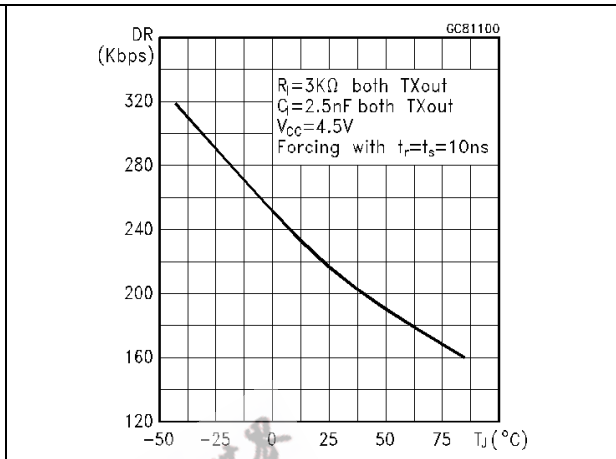

Figure 5. Receiver propagation delay

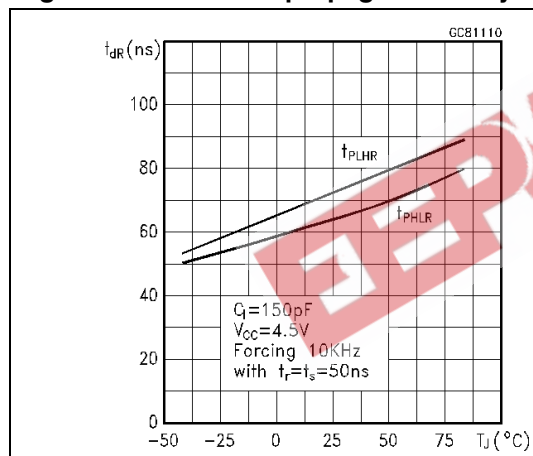

Figure 6. Driver propagation delay

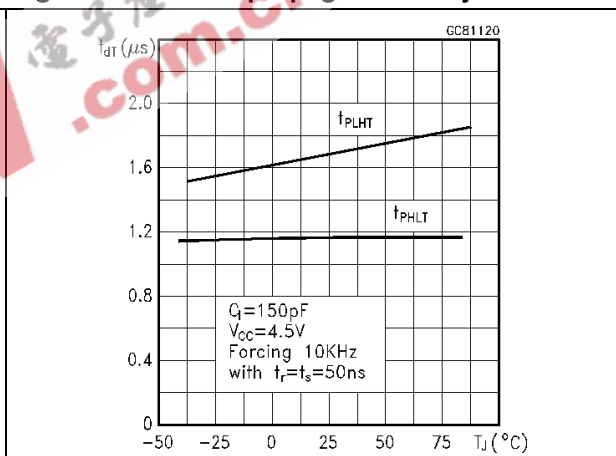

Figure 7. High level output voltage swing vs temperature

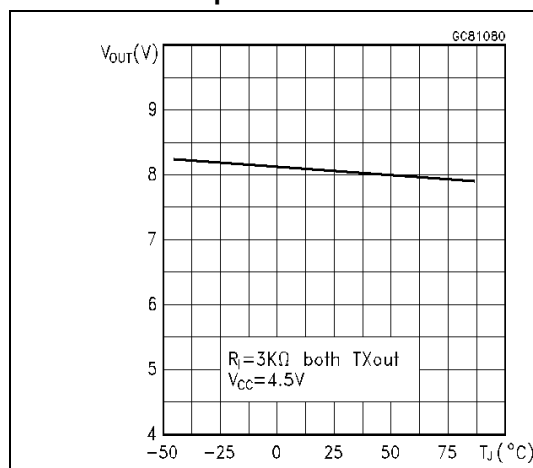

Figure 8. Low level output voltage swing vs temperature

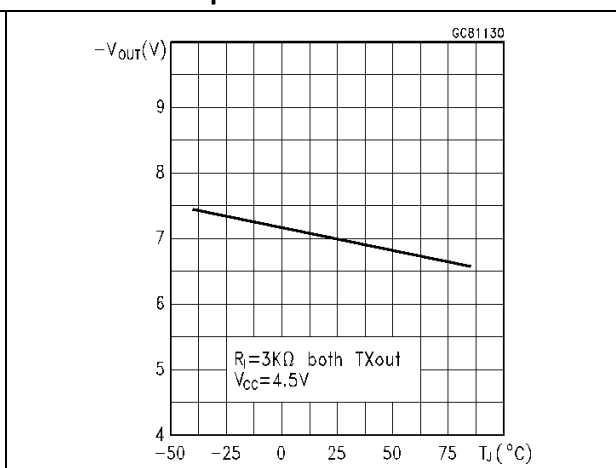

Figure 9. High level transmitter output short circuit current vs temperature

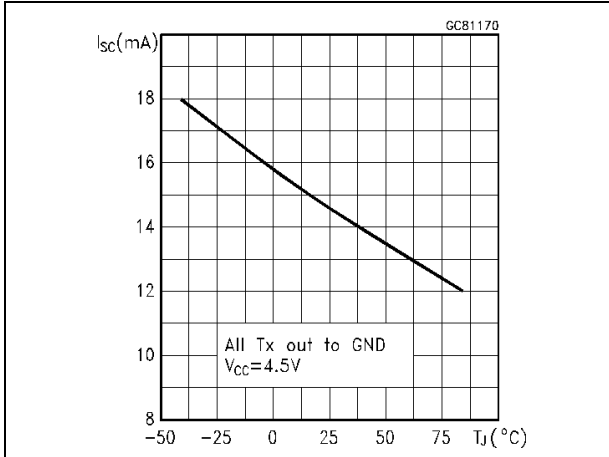

Figure 10. Low level transmitter output short circuit current vs temperature

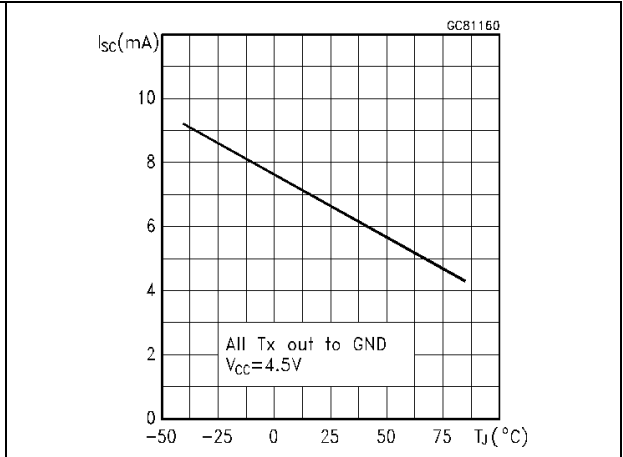

Figure 11. High level receiver output short circuit current vs temperature

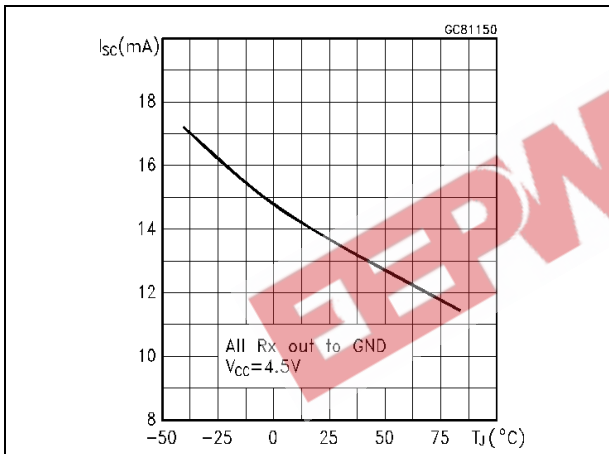
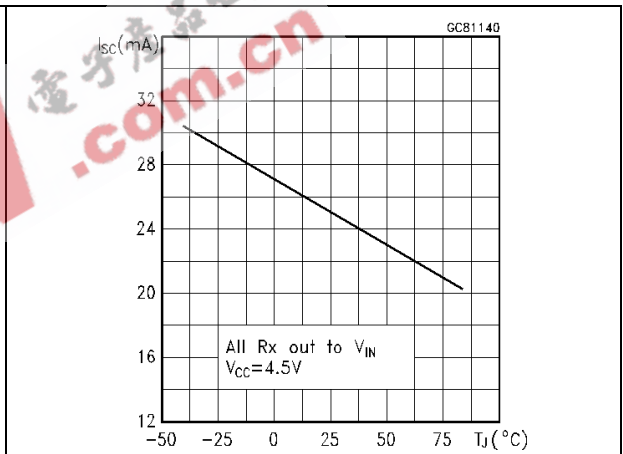

Figure 12. Low level receiver output short circuit current vs temperature



6 Package mechanical data

In order to meet environmental requirements, ST offers these devices in ECOPACK® packages. These packages have a lead-free second level interconnect. The category of second Level Interconnect is marked on the package and on the inner box label, in compliance with JEDEC Standard JESD97. The maximum ratings related to soldering conditions are also marked on the inner box label. ECOPACK is an ST trademark. ECOPACK specifications are available at: www.st.com.

EEPW 电子產品世界
.com.cn

SO-16 mechanical data

Dim.	mm.			inch.		
	Min.	Typ.	Max.	Min.	Typ.	Max.
A			1.75			0.068
a1	0.1		0.25	0.004		0.010
a2			1.64			0.063
b	0.35		0.46	0.013		0.018
b1	0.19		0.25	0.007		0.010
C		0.5			0.019	
c1	45° (typ.)					
D	9.8		10	0.385		0.393
E	5.8		6.2	0.228		0.244
e		1.27			0.050	
e3		8.89			0.350	
F	3.8		4.0	0.149		0.157
G	4.6		5.3	0.181		0.208
L	0.5		1.27	0.019		0.050
M			0.62			0.024
S	8° (max.)					

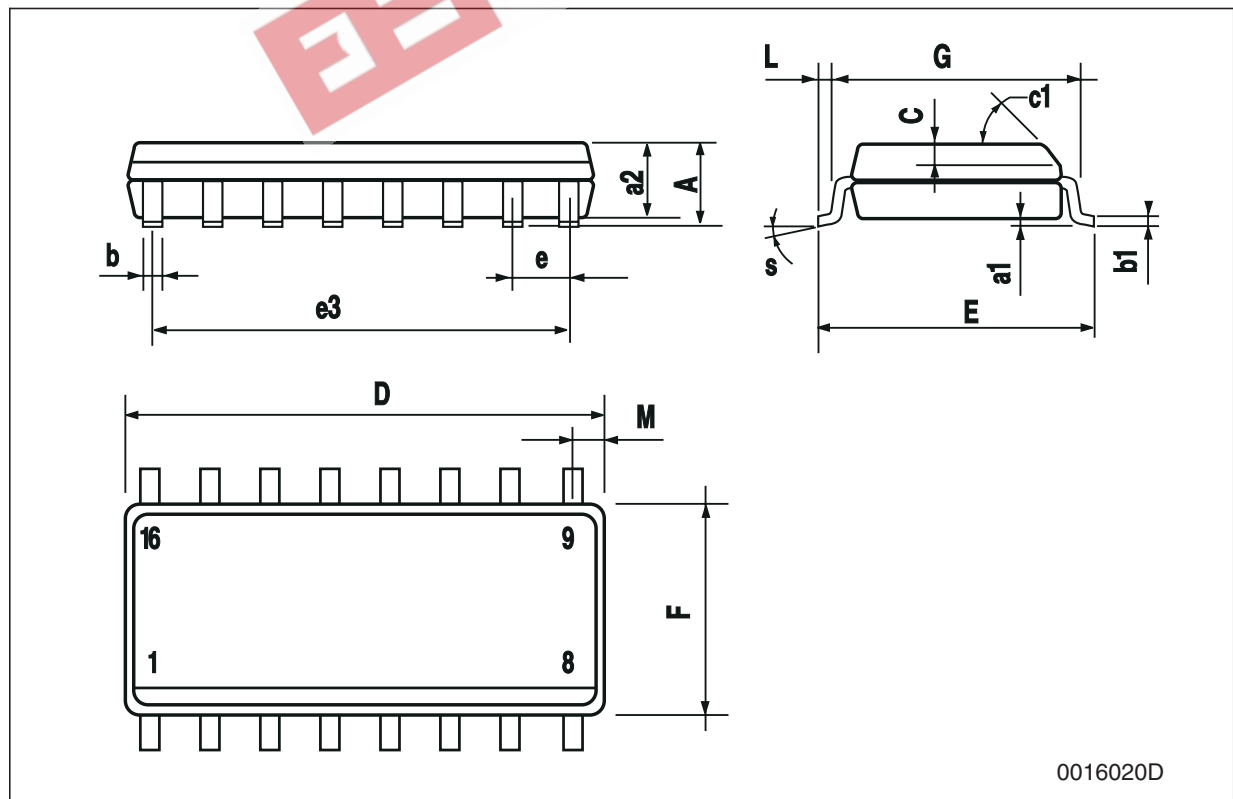

0016020D

SO-16L mechanical data

Dim.	mm.			inch.		
	Min.	Typ.	Max.	Min.	Typ.	Max.
A			2.65			0.104
a1	0.1		0.2	0.004		0.008
a2			2.45			0.096
b	0.35		0.49	0.014		0.019
b1	0.23		0.32	0.009		0.012
C		0.5			0.020	
c1	45° (typ.)					
D	10.1		10.5	0.397		0.413
E	10.0		10.65	0.393		0.419
e		1.27			0.050	
e3		8.89			0.350	
F	7.4		7.6	0.291		0.300
G						
L	0.5		1.27	0.020		0.050
M			0.75			0.029
S	8° (max.)					

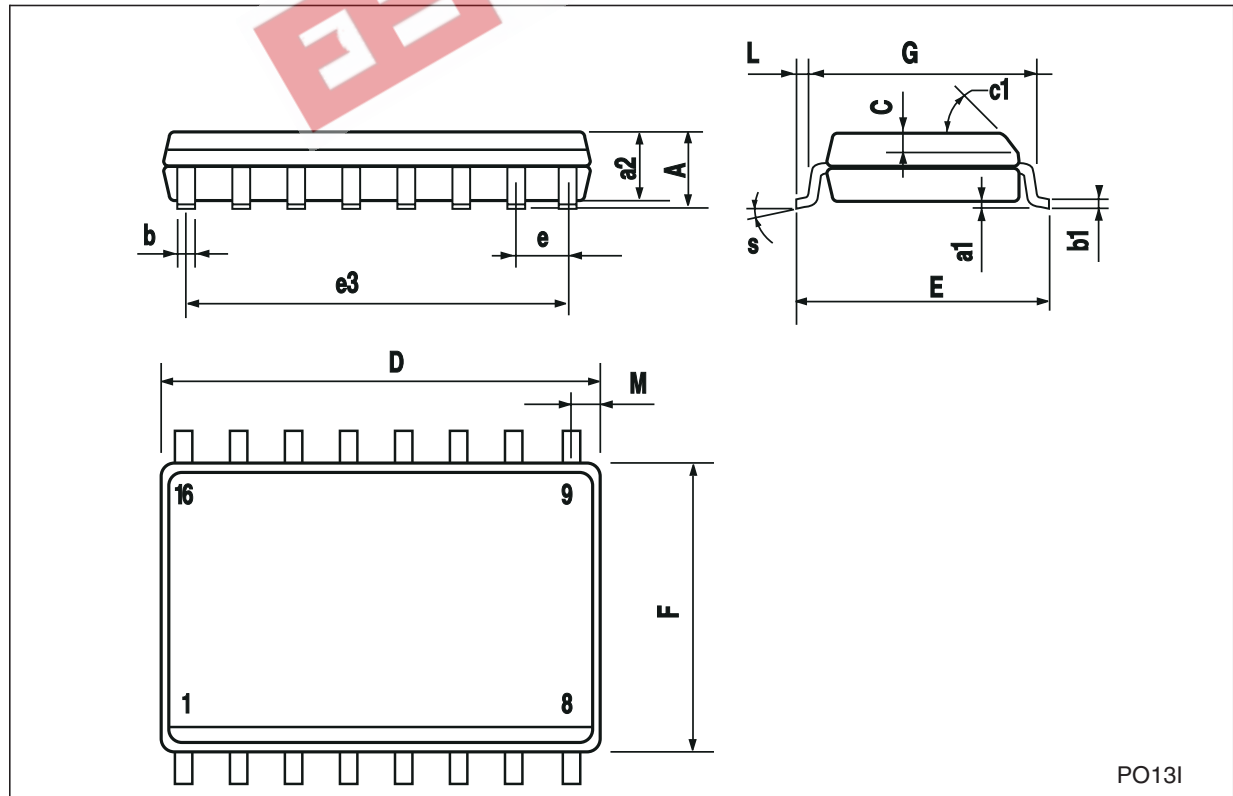

PO13I

TSSOP16 mechanical data

Dim.	mm.			inch.		
	Min.	Typ.	Max.	Min.	Typ.	Max.
A			1.2			0.047
A1	0.05		0.15	0.002	0.004	0.006
A2	0.8	1	1.05	0.031	0.039	0.041
b	0.19		0.30	0.007		0.012
c	0.09		0.20	0.004		0.0079
D	4.9	5	5.1	0.193	0.197	0.201
E	6.2	6.4	6.6	0.244	0.252	0.260
E1	4.3	4.4	4.48	0.169	0.173	0.176
e		0.65 BSC			0.0256 BSC	
K	0°		8°	0°		8°
L	0.45	0.60	0.75	0.018	0.024	0.030

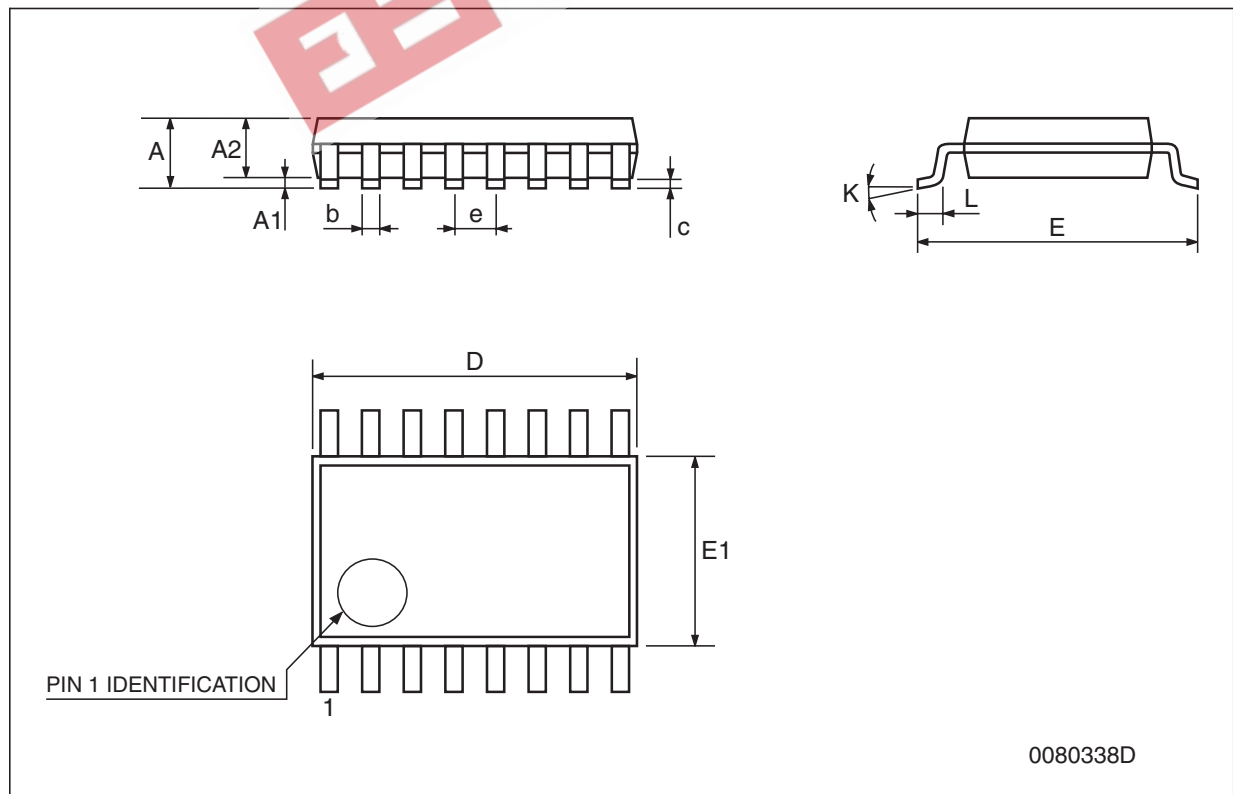

Tape & reel SO-16 mechanical data

Dim.	mm.			inch.		
	Min.	Typ.	Max.	Min.	Typ.	Max.
A			330			12.992
C	12.8		13.2	0.504		0.519
D	20.2			0.795		
N	60			2.362		
T			22.4			0.882
Ao	6.45		6.65	0.254		0.262
Bo	10.3		10.5	0.406		0.414
Ko	2.1		2.3	0.082		0.090
Po	3.9		4.1	0.153		0.161
P	7.9		8.1	0.311		0.319

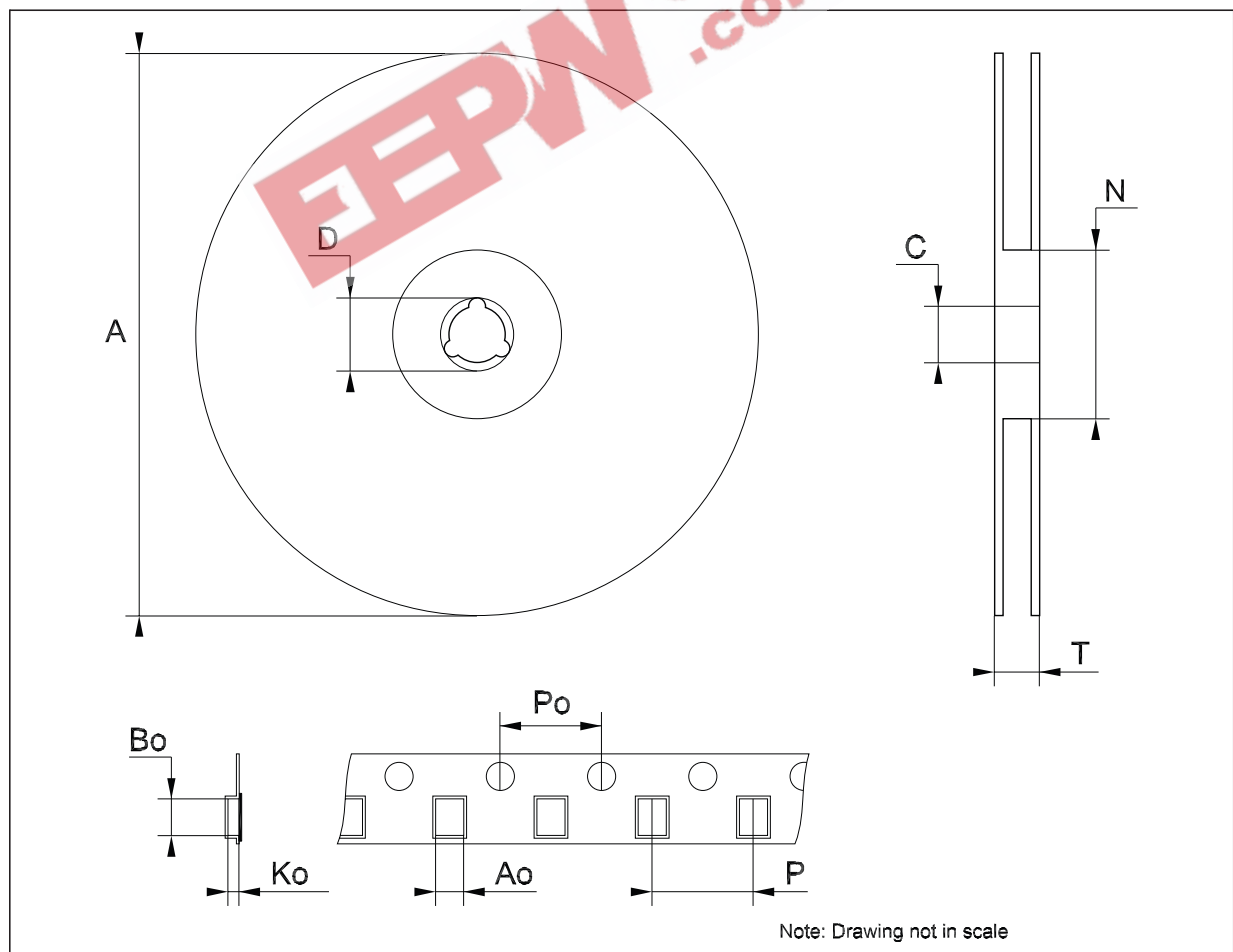

Note: Drawing not in scale

Tape & reel SO-16L mechanical data

Dim.	mm.			inch.		
	Min.	Typ.	Max.	Min.	Typ.	Max.
A			330			12.992
C	12.8		13.2	0.504		0.519
D	20.2			0.795		
N	60			2.362		
T			22.4			0.882
Ao	10.8		11.0	0.425		0.433
Bo	10.7		10.9	0.421		0.429
Ko	2.9		3.1	0.114		0.122
Po	3.9		4.1	0.153		0.161
P	11.9		12.1	0.468		0.476

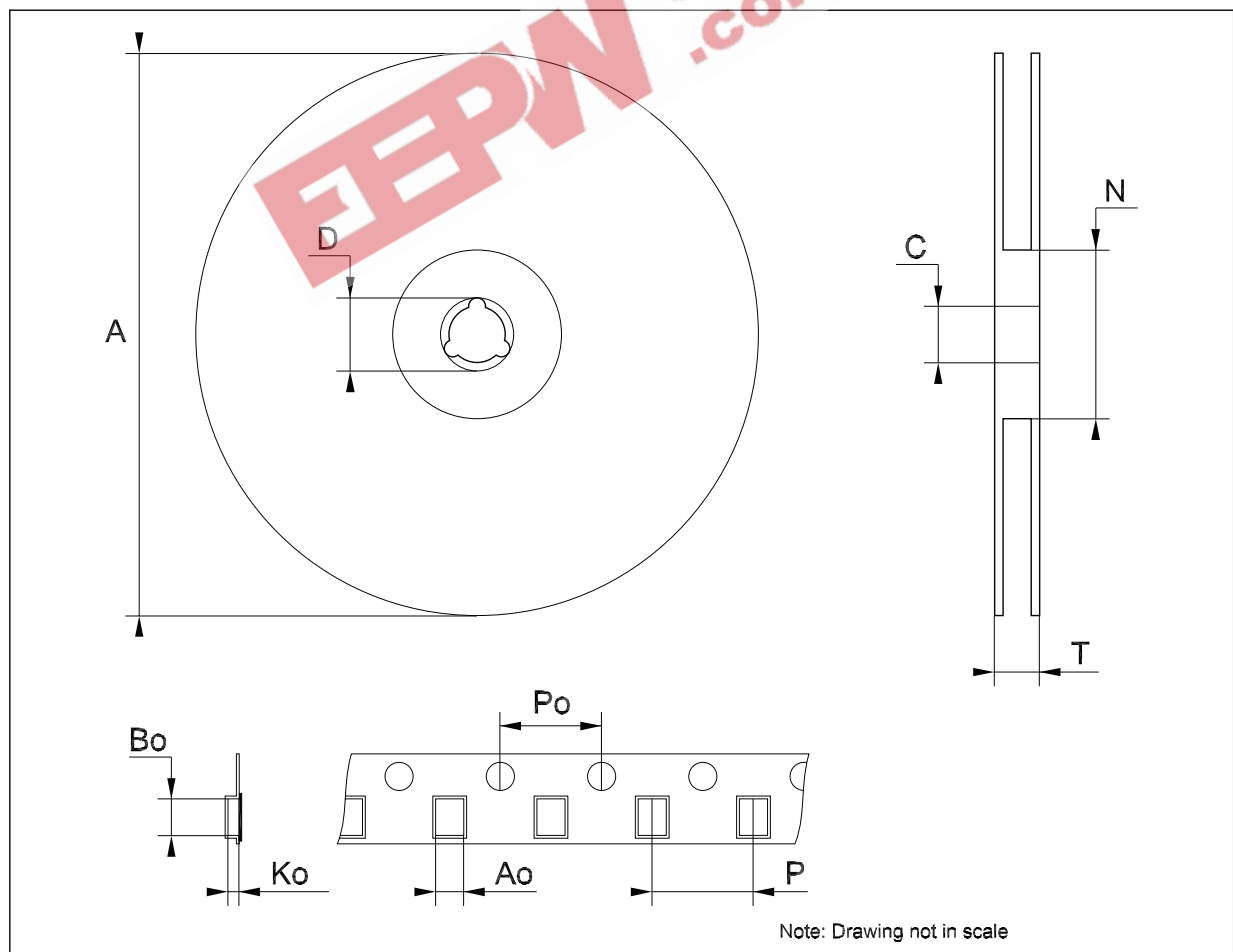

Tape & reel TSSOP16 mechanical data

Dim.	mm.			inch.		
	Min.	Typ.	Max.	Min.	Typ.	Max.
A			330			12.992
C	12.8		13.2	0.504		0.519
D	20.2			0.795		
N	60			2.362		
T			22.4			0.882
Ao	6.7		6.9	0.264		0.272
Bo	5.3		5.5	0.209		0.217
Ko	1.6		1.8	0.063		0.071
Po	3.9		4.1	0.153		0.161
P	7.9		8.1	0.311		0.319

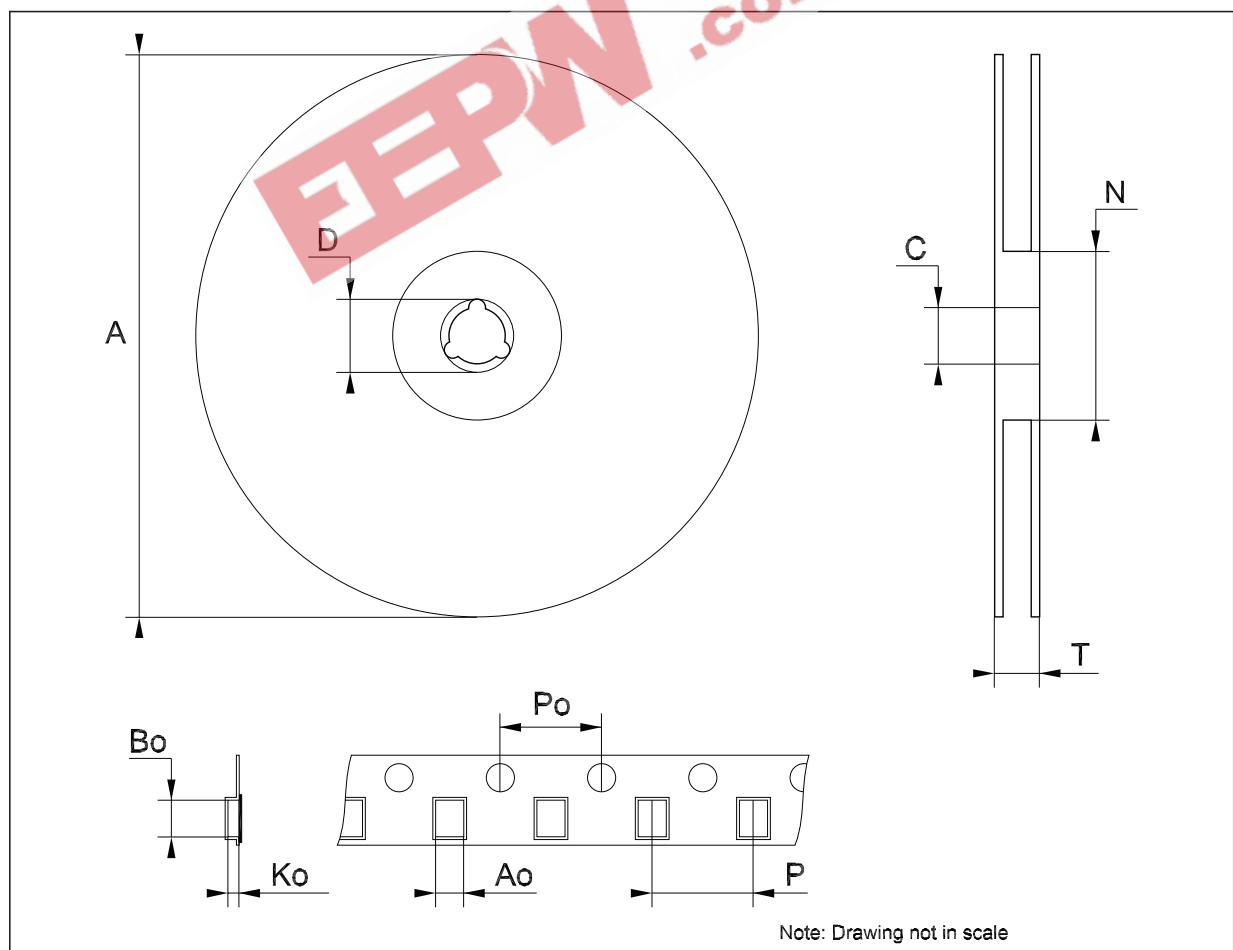

7 Revision history

Table 9. Document revision history

Date	Revision	Changes
21-Feb-2006	12	Change value of I_{TIL} on transmitter characteristics, $\pm 1\mu A \Rightarrow \pm 10\mu A$.
14-Mar-2006	13	Order codes has been updated and new template.
27-Aug-2007	14	Added Table 1 in cover page.
13-Nov-2007	15	Modified: Table 1 .
08-feb-2008	16	Modified: Table 1 on page 1 .

EEPW 电子產品世界
.com.cn

Please Read Carefully:

Information in this document is provided solely in connection with ST products. STMicroelectronics NV and its subsidiaries ("ST") reserve the right to make changes, corrections, modifications or improvements, to this document, and the products and services described herein at any time, without notice.

All ST products are sold pursuant to ST's terms and conditions of sale.

Purchasers are solely responsible for the choice, selection and use of the ST products and services described herein, and ST assumes no liability whatsoever relating to the choice, selection or use of the ST products and services described herein.

No license, express or implied, by estoppel or otherwise, to any intellectual property rights is granted under this document. If any part of this document refers to any third party products or services it shall not be deemed a license grant by ST for the use of such third party products or services, or any intellectual property contained therein or considered as a warranty covering the use in any manner whatsoever of such third party products or services or any intellectual property contained therein.

UNLESS OTHERWISE SET FORTH IN ST'S TERMS AND CONDITIONS OF SALE ST DISCLAIMS ANY EXPRESS OR IMPLIED WARRANTY WITH RESPECT TO THE USE AND/OR SALE OF ST PRODUCTS INCLUDING WITHOUT LIMITATION IMPLIED WARRANTIES OF MERCHANTABILITY, FITNESS FOR A PARTICULAR PURPOSE (AND THEIR EQUIVALENTS UNDER THE LAWS OF ANY JURISDICTION), OR INFRINGEMENT OF ANY PATENT, COPYRIGHT OR OTHER INTELLECTUAL PROPERTY RIGHT.

UNLESS EXPRESSLY APPROVED IN WRITING BY AN AUTHORIZED ST REPRESENTATIVE, ST PRODUCTS ARE NOT RECOMMENDED, AUTHORIZED OR WARRANTED FOR USE IN MILITARY, AIR CRAFT, SPACE, LIFE SAVING, OR LIFE SUSTAINING APPLICATIONS, NOR IN PRODUCTS OR SYSTEMS WHERE FAILURE OR MALFUNCTION MAY RESULT IN PERSONAL INJURY, DEATH, OR SEVERE PROPERTY OR ENVIRONMENTAL DAMAGE. ST PRODUCTS WHICH ARE NOT SPECIFIED AS "AUTOMOTIVE GRADE" MAY ONLY BE USED IN AUTOMOTIVE APPLICATIONS AT USER'S OWN RISK.

Resale of ST products with provisions different from the statements and/or technical features set forth in this document shall immediately void any warranty granted by ST for the ST product or service described herein and shall not create or extend in any manner whatsoever, any liability of ST.

ST and the ST logo are trademarks or registered trademarks of ST in various countries.

Information in this document supersedes and replaces all information previously supplied.

The ST logo is a registered trademark of STMicroelectronics. All other names are the property of their respective owners.

© 2008 STMicroelectronics - All rights reserved

STMicroelectronics group of companies

Australia - Belgium - Brazil - Canada - China - Czech Republic - Finland - France - Germany - Hong Kong - India - Israel - Italy - Japan - Malaysia - Malta - Morocco - Singapore - Spain - Sweden - Switzerland - United Kingdom - United States of America

www.st.com