

54/74156 54LS/74LS156

DUAL 1-OF-4 DECODER/DEMULTIPLEXER
(With Open-Collector Outputs)

CONNECTION DIAGRAM PINOUT A

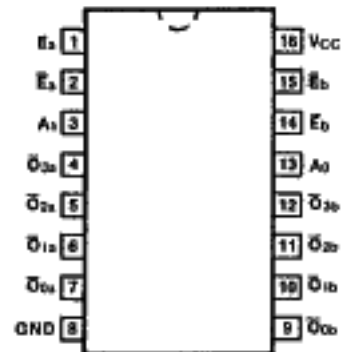

DESCRIPTION — The '156 contains two decoders with common Address (A_0 , A_1) inputs and separate enable gates. Decoder "a" has an enable gate with one active HIGH and one active LOW input, while decoder "b" has two active LOW inputs. If the enable functions are satisfied, one output of each decoder will be LOW, as selected by the Address inputs. For functional description, truth table and logic diagram, please refer to the '155 data sheet.

ORDERING CODE: See Section 9

PKGS	PIN OUT	COMMERCIAL GRADE	MILITARY GRADE	PKG TYPE
		$V_{CC} = +5.0 \text{ V} \pm 5\%$ $T_A = 0^\circ \text{C to } +70^\circ \text{C}$	$V_{CC} = +5.0 \text{ V} \pm 10\%$ $T_A = -55^\circ \text{C to } +125^\circ \text{C}$	
Plastic DIP (P)	A	74156PC, 74LS156PC		9B
Ceramic DIP (D)	A	74156DC, 74LS156DC	54156DM, 54LS156DM	6B
Flatpak (F)	A	74156FC, 74LS156FC	54156FM, 54LS156FM	4L

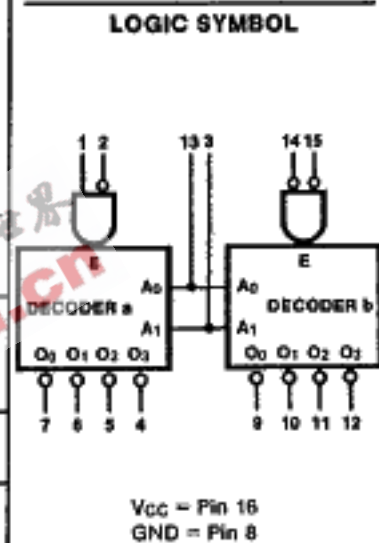

INPUT LOADING/FAN-OUT: See Section 3 for U.L. definitions

PIN NAMES	DESCRIPTION	54/74 (U.L.) HIGH/LOW	54/74LS (U.L.) HIGH/LOW
A_0, A_1	Address Inputs	1.0/1.0	0.5/0.25
\bar{E}_a, \bar{E}_b	Enable Inputs (Active LOW)	1.0/1.0	0.5/0.25
E_a	Enable Input (Active HIGH)	1.0/1.0	0.5/0.25
$\bar{O}_0 - \bar{O}_3$	Outputs (Active LOW)	OC*/10	OC*/5.0 (2.5)

*OC — Open Collector

DC CHARACTERISTICS OVER OPERATING TEMPERATURE RANGE (unless otherwise specified)

SYMBOL	PARAMETER	54/74		54/74LS		UNITS	CONDITIONS
		Min	Max	Min	Max		
I _{OH}	Output HIGH Current, OFF State	250		100		μA	V _{CC} =Min, V _{OH} = 5.5 V
I _{CC}	Power Supply Current	XM	35	10	mA	V _{CC} =Max; E _a , E _b = GND A ₀ , A ₁ , E _a =4.5 V	
		XC	40	10			

AC CHARACTERISTICS: V_{CC} = 5.0 V, T_A = 25°C (See Section 3 for waveforms and load configurations)

SYMBOL	PARAMETER	54/74		54/74LS		UNITS	CONDITIONS
		C _L = 15 pF R _L = 400 Ω		C _L = 15 pF R _L = 2 kΩ			
		Min	Max	Min	Max		
t _{PLH} t _{PHL}	Propagation Delay A _n to \bar{O}_n	34 34	28 33	ns	Figs. 3-2, 3-20		
t _{PLH} t _{PHL}	Propagation Delay \bar{E}_a or \bar{E}_b to \bar{O}_n	23 30	25 30	ns	Figs. 3-2, 3-5		
t _{PLH} t _{PHL}	Propagation Delay E _a to \bar{O}_n	27 33	34 34	ns	Figs. 3-2, 3-4		

4

EEPW 电子产品世界
.com.cn