

IS62LV12816L

ISSI®

128K x 16 CMOS STATIC RAM

ADVANCE INFORMATION
AUGUST 1998

FEATURES

- High-speed access time: 70, 100, and 120 ns
- CMOS low power operation
 - 120 mW (typical) operating
 - 6 μ W (typical) CMOS standby
- TTL compatible interface levels
- Single $3V \pm 10\%$ V_{CC} power supply
- Fully static operation: no clock or refresh required
- Three state outputs
- Data control for upper and lower bytes
- Industrial temperature available
- Available in the 44-pin TSOP (Type II) and 48-pin mini BGA

DESCRIPTION

The *ISSI* IS62LV12816L is a high-speed, 2,097,152-bit static RAM organized as 131,072 words by 16 bits. It is fabricated using *ISSI*'s high-performance CMOS technology. This highly reliable process coupled with innovative circuit design techniques, yields high-performance and low power consumption devices.

When \overline{CE} is HIGH (deselected), the device assumes a standby mode at which the power dissipation can be reduced down with CMOS input levels.

Easy memory expansion is provided by using Chip Enable and Output Enable inputs, \overline{CE} and \overline{OE} . The active LOW Write Enable (\overline{WE}) controls both writing and reading of the memory. A data byte allows Upper Byte (\overline{UB}) and Lower Byte (\overline{LB}) access.

The IS62LV12816L is packaged in the JEDEC standard 44-pin TSOP (Type II) and 48-pin mini BGA.

FUNCTIONAL BLOCK DIAGRAM

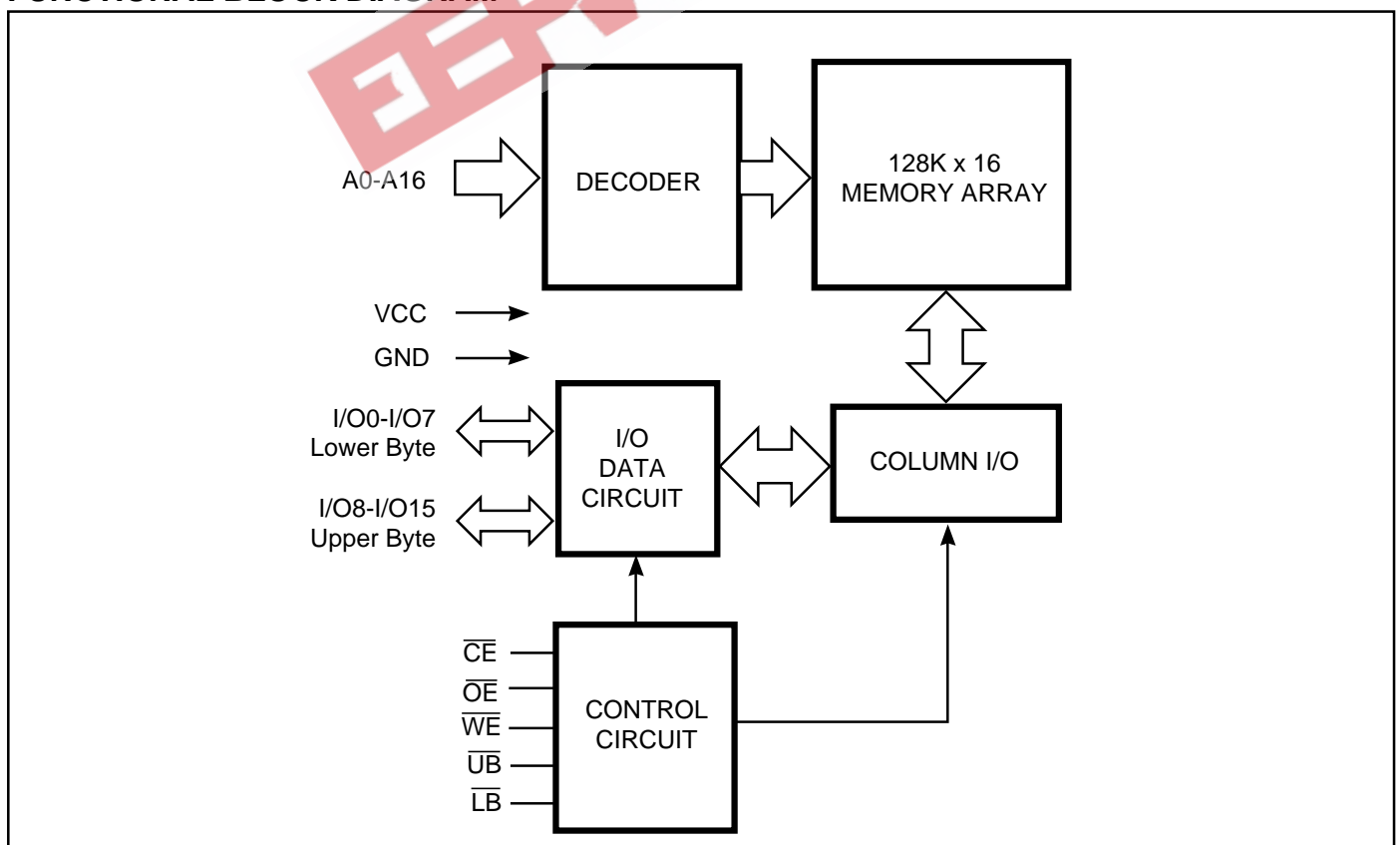

The specification contains ADVANCE INFORMATION. ISSI reserves the right to make changes to its products at any time without notice in order to improve design and supply the best possible product. We assume no responsibility for any errors which may appear in this publication. © Copyright 1998, Integrated Silicon Solution, Inc.

Integrated Silicon Solution, Inc.

ADVANCE INFORMATION SR002-0C

08/20/98

PIN CONFIGURATIONS

44-Pin TSOP (Type II)

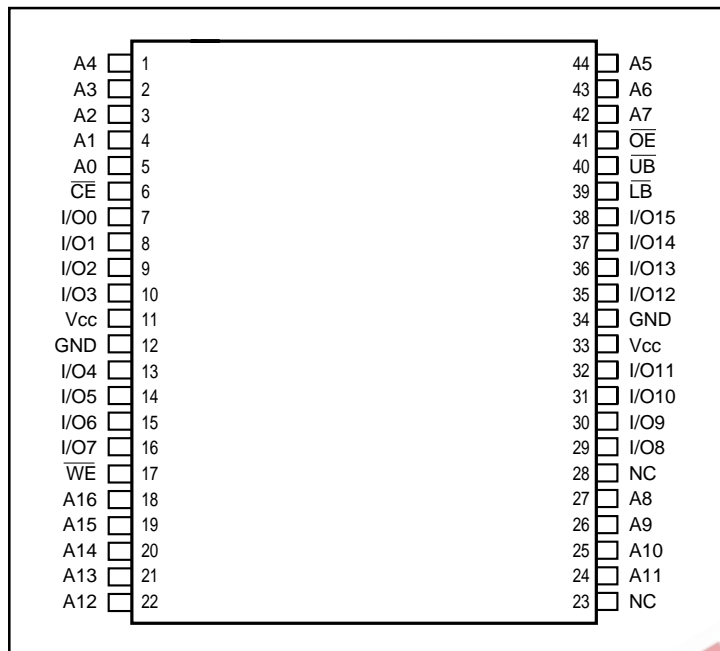

48-Pin mini BGA

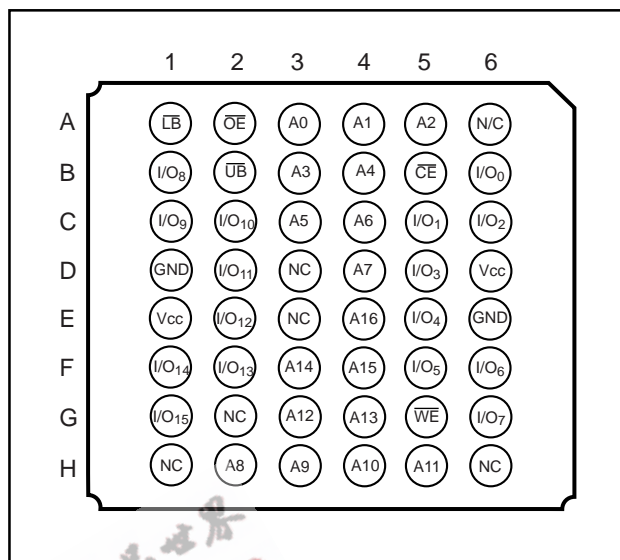

PIN DESCRIPTIONS

A0-A16	Address Inputs
I/O0-I/O15	Data Inputs/Outputs
\overline{CE}	Chip Enable Input
\overline{OE}	Output Enable Input
\overline{WE}	Write Enable Input

\overline{LB}	Lower-byte Control (I/O0-I/O7)
\overline{UB}	Upper-byte Control (I/O8-I/O15)
NC	No Connection
Vcc	Power
GND	Ground

TRUTH TABLE

Mode	\overline{WE}	\overline{CE}	\overline{OE}	\overline{LB}	\overline{UB}	I/O PIN		Vcc Current
						I/O0-I/O7	I/O8-I/O15	
Not Selected	X	H	X	X	X	High-Z	High-Z	I _{sb1} , I _{sb2}
Output Disabled	H	L	H	X	X	High-Z	High-Z	I _{cc}
	X	L	X	H	H	High-Z	High-Z	
Read	H	L	L	L	H	DOUT	High-Z	I _{cc}
	H	L	L	H	L	High-Z	DOUT	
	H	L	L	L	L	DOUT	DOUT	
Write	L	L	X	L	H	DIN	High-Z	I _{cc}
	L	L	X	H	L	High-Z	DIN	
	L	L	X	L	L	DIN	DIN	

OPERATING RANGE

Range	Ambient Temperature	V _{CC}
Commercial	0°C to +70°C	3.0V ± 10%
Industrial	-40°C to +85°C	3.0V ± 10%

ABSOLUTE MAXIMUM RATINGS⁽¹⁾

Symbol	Parameter	Value	Unit
V _{TERM}	Terminal Voltage with Respect to GND	-0.5 to V _{CC} +0.5	V
T _{BIAS}	Temperature Under Bias	-40 to +85	°C
V _{CC}	V _{CC} Related to GND	-0.3 to +4.0	V
T _{STG}	Storage Temperature	-65 to +150	°C
P _T	Power Dissipation	1.0	W

Note:

1. Stress greater than those listed under ABSOLUTE MAXIMUM RATINGS may cause permanent damage to the device. This is a stress rating only and functional operation of the device at these or any other conditions above those indicated in the operational sections of this specification is not implied. Exposure to absolute maximum rating conditions for extended periods may affect reliability.

DC ELECTRICAL CHARACTERISTICS (Over Operating Range)

Symbol	Parameter	Test Conditions	Min.	Max.	Unit
V _{OH}	Output HIGH Voltage	V _{CC} = Min., I _{OH} = -1 mA	2.0	—	V
V _{OL}	Output LOW Voltage	V _{CC} = Min., I _{OL} = 2.1 mA	—	0.4	V
V _{IH}	Input HIGH Voltage		2.2	V _{CC} + 0.2	V
V _{IL} ⁽¹⁾	Input LOW Voltage		-0.2	0.4	V
I _{LI}	Input Leakage	GND ≤ V _{IN} ≤ V _{CC}	-1	1	μA
I _{LO}	Output Leakage	GND ≤ V _{OUT} ≤ V _{CC} , Outputs Disabled	-1	1	μA

Notes:

1. V_{IL} (min.) = -2.0V for pulse width less than 10 ns.

POWER SUPPLY CHARACTERISTICS⁽¹⁾ (Over Operating Range)

Symbol	Parameter	Test Conditions	-70		-100		-120		Unit	
			Min.	Max.	Min.	Max.	Min.	Max.		
I _{CC}	V _{CC} Dynamic Operating Supply Current	V _{CC} = Max., I _{OUT} = 0 mA, f = f _{MAX}	Com.	—	40	—	30	—	20	mA
I _{SB1}	TTL Standby Current (TTL Inputs)	V _{CC} = Max., V _{IN} = V _{IH} or V _{IL} CE ≥ V _{IH} , f = 0	Com.	—	0.4	—	0.4	—	0.4	mA
			Ind.	—	1.0	—	1.0	—	1.0	
I _{SB2}	CMOS Standby Current (CMOS Inputs)	V _{CC} = Max., CE ≥ V _{CC} - 0.2V, V _{IN} ≥ V _{CC} - 0.2V, or V _{IN} ≤ 0.2V, f = 0	Com.	—	15	—	15	—	15	μA
			Ind.	—	25	—	25	—	25	

Note:

1. At f = f_{MAX}, address and data inputs are cycling at the maximum frequency, f = 0 means no input lines change.

CAPACITANCE⁽¹⁾

Symbol	Parameter	Conditions	Max.	Unit
C _{IN}	Input Capacitance	V _{IN} = 0V	6	pF
C _{OUT}	Input/Output Capacitance	V _{OUT} = 0V	8	pF

Note:

1. Tested initially and after any design or process changes that may affect these parameters.

AC TEST CONDITIONS

Parameter	Unit
Input Pulse Level	0.4V to 2.2V
Input Rise and Fall Times	5 ns
Input and Output Timing and Reference Level	1.5V
Output Load	See Figures 1 and 2

AC TEST LOADS

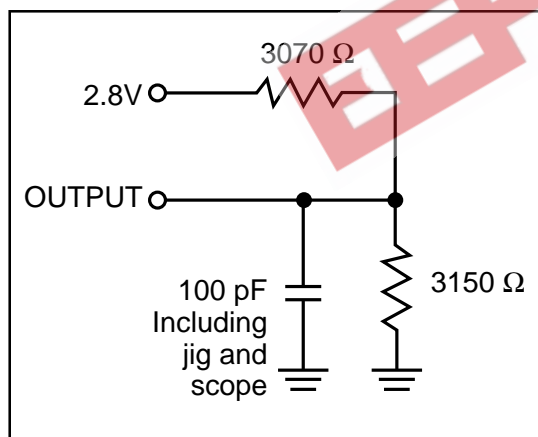

Figure 1

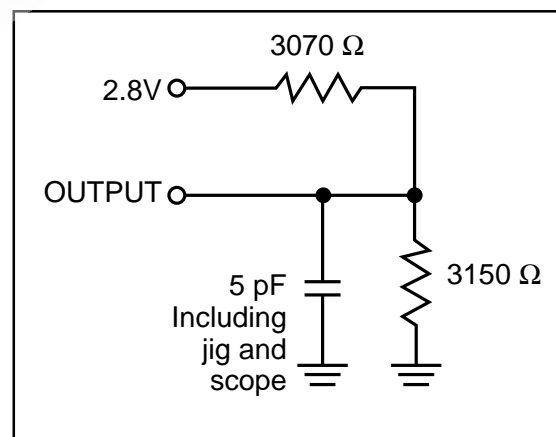

Figure 2

READ CYCLE SWITCHING CHARACTERISTICS⁽¹⁾ (Over Operating Range)

Symbol	Parameter	-70		-100		-120		Unit
		Min.	Max.	Min.	Max.	Min.	Max.	
t _{RC}	Read Cycle Time	70	—	100	—	120	—	ns
t _{AA}	Address Access Time	—	70	—	100	—	120	ns
t _{OHA}	Output Hold Time	10	—	15	—	15	—	ns
t _{ACE}	\overline{CE} Access Time	—	70	—	100	—	120	ns
t _{DOE}	\overline{OE} Access Time	—	35	—	50	—	60	ns
t _{HZOE} ⁽²⁾	\overline{OE} to High-Z Output	—	25	—	30	0	40	ns
t _{LZOE} ⁽²⁾	\overline{OE} to Low-Z Output	5	—	5	—	5	—	ns
t _{HZCE} ⁽²⁾	\overline{CE} to High-Z Output	0	25	0	30	0	40	ns
t _{LZCE} ⁽²⁾	\overline{CE} to Low-Z Output	10	—	10	—	10	—	ns
t _{BA}	\overline{LB} , \overline{UB} Access Time	—	35	—	50	—	60	ns
t _{HZB}	\overline{LB} , \overline{UB} to High-Z Output	0	25	0	35	0	50	ns
t _{LZB}	\overline{LB} , \overline{UB} to Low-Z Output	0	—	0	—	0	—	ns

Notes:

1. Test conditions assume signal transition times of 5 ns or less, timing reference levels of 1.5V, input pulse levels of 0.4 to 2.2V and output loading specified in Figure 1.
2. Tested with the load in Figure 2. Transition is measured ± 500 mV from steady-state voltage. Not 100% tested.

AC WAVEFORMS

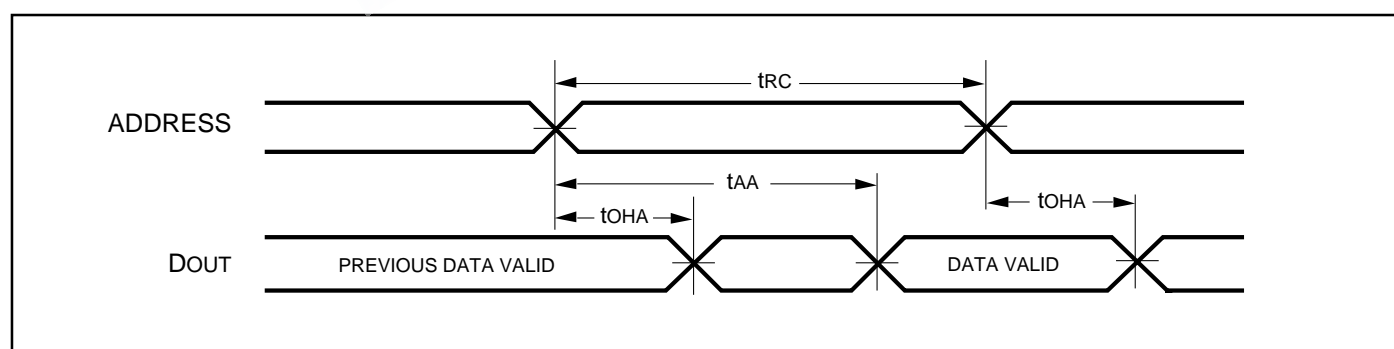
READ CYCLE NO. 1^(1,2) (Address Controlled) ($\overline{CE} = \overline{OE} = V_{IL}$, \overline{UB} or $\overline{LB} = V_{IL}$)

AC WAVEFORMS

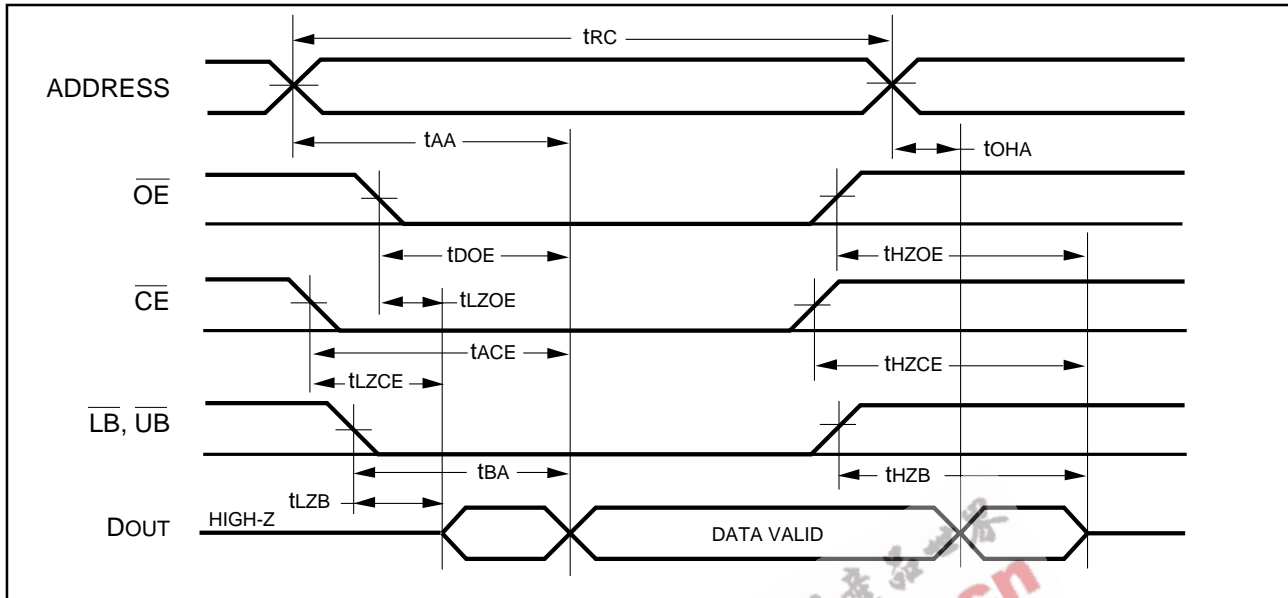
READ CYCLE NO. 2^(1,3)**Notes:**

1. \overline{WE} is HIGH for a Read Cycle.
2. The device is continuously selected. \overline{OE} , \overline{CE} , \overline{UB} , or $\overline{LB} = V_{IL}$.
3. Address is valid prior to or coincident with \overline{CE} LOW transition.

WRITE CYCLE SWITCHING CHARACTERISTICS^(1,2) (Over Operating Range)

Symbol	Parameter	-70		-100		-120		Unit
		Min.	Max.	Min.	Max.	Min.	Max.	
t _{WC}	Write Cycle Time	70	—	100	—	120	—	ns
t _{SCE}	\overline{CE} to Write End	65	—	80	—	100	—	ns
t _{AW}	Address Setup Time to Write End	65	—	80	—	100	—	ns
t _{HA}	Address Hold from Write End	0	—	0	—	0	—	ns
t _{SA}	Address Setup Time	0	—	0	—	0	—	ns
t _{PWB}	\overline{LB} , \overline{UB} Valid to End of Write	60	—	80	—	100	—	ns
t _{PWE}	\overline{WE} Pulse Width	60	—	80	—	100	—	ns
t _{SD}	Data Setup to Write End	30	—	40	—	50	—	ns
t _{HD}	Data Hold from Write End	0	—	0	—	0	—	ns
t _{HZWE} ⁽³⁾	\overline{WE} LOW to High-Z Output	—	30	—	40	—	50	ns
t _{LZWE} ⁽³⁾	\overline{WE} HIGH to Low-Z Output	5	—	5	—	5	—	ns

Notes:

1. Test conditions assume signal transition times of 3 ns or less, timing reference levels of 1.5V, input pulse levels of 0.4V to 2.2V and output loading specified in Figure 1.
2. The internal write time is defined by the overlap of \overline{CE} LOW and \overline{UB} or \overline{LB} , and \overline{WE} LOW. All signals must be in valid states to initiate a Write, but any one can go inactive to terminate the Write. The Data Input Setup and Hold timing are referenced to the rising or falling edge of the signal that terminates the write.
3. Tested with the load in Figure 2. Transition is measured ± 500 mV from steady-state voltage. Not 100% tested.

AC WAVEFORMS

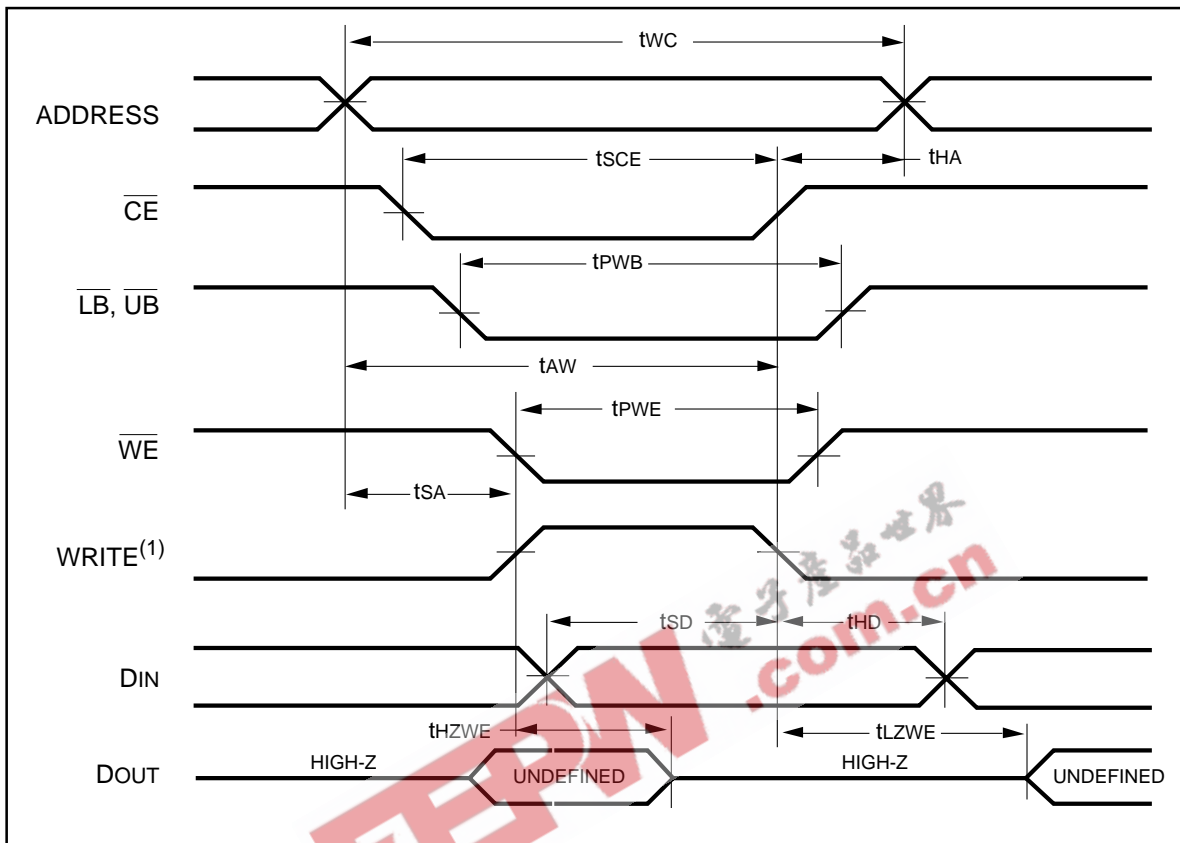
WRITE CYCLE NO. 1^(1,2) (\overline{WE} Controlled)**Notes:**

1. WRITE is an internally generated signal asserted during an overlap of the LOW states on the \overline{CE} and \overline{WE} inputs and at least one of the \overline{LB} and \overline{UB} inputs being in the LOW state.
2. WRITE = $(\overline{CE}) [(\overline{LB}) = (\overline{UB})] (\overline{WE})$.

ORDERING INFORMATION**Commercial Range: 0°C to +70°C**

Speed (ns)	Order Part No.	Package
70	IS62LV12816L-70T	TSOP (Type II)
70	IS62LV12816L-70B	Mini BGA
100	IS62LV12816L-100T	TSOP (Type II)
100	IS62LV12816L-100B	Mini BGA
120	IS62LV12816L-120T	TSOP (Type II)
120	IS62LV12816L-120B	Mini BGA

Industrial Range: -40°C to +85°C

Speed (ns)	Order Part No.	Package
70	IS62LV12816L-70TI	TSOP (Type II)
70	IS62LV12816L-70BI	Mini BGA
100	IS62LV12816L-100TI	TSOP (Type II)
100	IS62LV12816L-100BI	Mini BGA
120	IS62LV12816L-120TI	TSOP (Type II)
120	IS62LV12816L-120BI	Mini BGA

ISSI®

Integrated Silicon Solution, Inc.

2231 Lawson Lane
 Santa Clara, CA 95054
 Fax: (408) 588-0806
 Toll Free: 1-800-379-4774
 email: sales@issi.com
<http://www.issi.com>