

## 24-bit, 192kHz 6-Channel Codec with Volume Control

### DESCRIPTION

The WM8772 is a multi-channel audio codec ideal for DVD and surround sound processing applications for home hi-fi, automotive and other audio visual equipment.

A stereo 24-bit multi-bit sigma delta ADC is used. Digital audio output word lengths from 16-32 bits and sampling rates from 32kHz to 96kHz are supported. The 32-lead version allows separate ADC and DAC samples rates.

Three stereo 24-bit multi-bit sigma delta DACs are used with oversampling digital interpolation filters. Digital audio input word lengths from 16-32 bits and sampling rates from 8kHz to 192kHz are supported. Each DAC channel has independent digital volume and mute control.

The audio data interface supports I<sup>2</sup>S, left justified, right justified and DSP digital audio formats.

The device is controlled via a 3 wire serial interface. The interface provides access to all features including channel selection, volume controls, mutes, de-emphasis and power management facilities. The device is available in a 28-pin SSOP or 32 pin TQFP.

### FEATURES

- Audio Performance
  - 103dB SNR ('A' weighted @ 48kHz) DAC
  - 100dB SNR ('A' weighted @ 48kHz) ADC (TQFP)
- DAC Sampling Frequency: 8kHz – 192kHz
- ADC Sampling Frequency: 32kHz – 96kHz
- ADC and DAC can run at different sample rates (32 pin TQFP version only)
- 3-Wire SPI Serial or Hardware Control Interface
- Programmable Audio Data Interface Modes
  - I<sup>2</sup>S, Left, Right Justified or DSP
  - 16/20/24/32 bit Word Lengths
- Three Independent stereo DAC outputs with independent digital volume controls
- Master or Slave Audio Data Interface
- 2.7V to 5.5V Analogue, 2.7V to 3.6V Digital supply Operation
- 28 pin SSOP or 32 pin TQFP Package

### APPLICATIONS

- DVD Players
- Surround Sound AV Processors and Hi-Fi systems
- Automotive Audio

### BLOCK DIAGRAM - 28 PIN SSOP

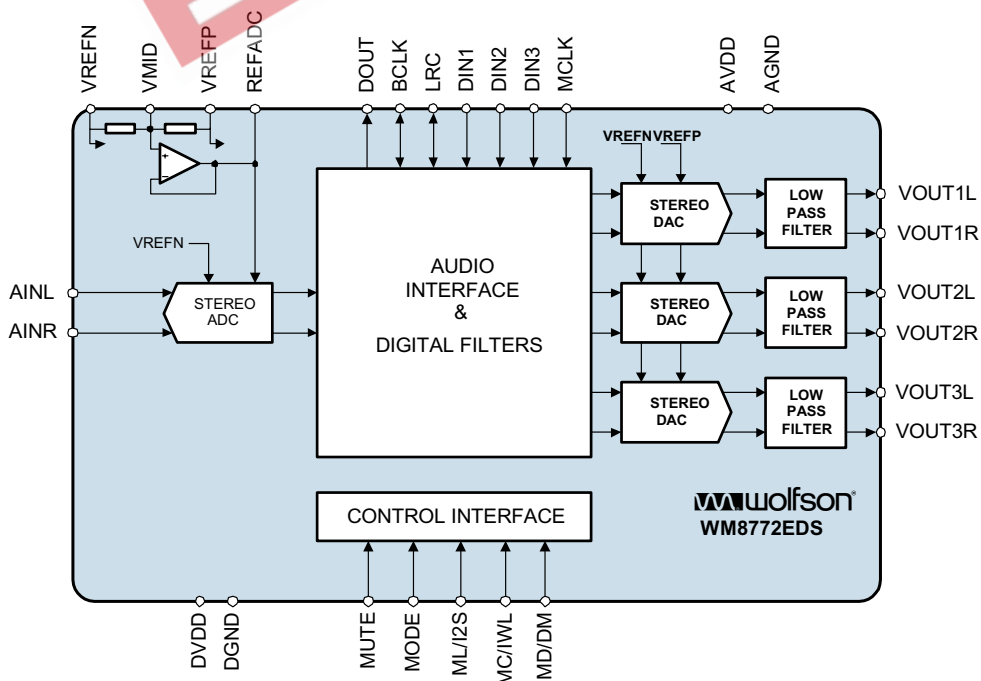

BLOCK DIAGRAM – 32 PIN TQFP

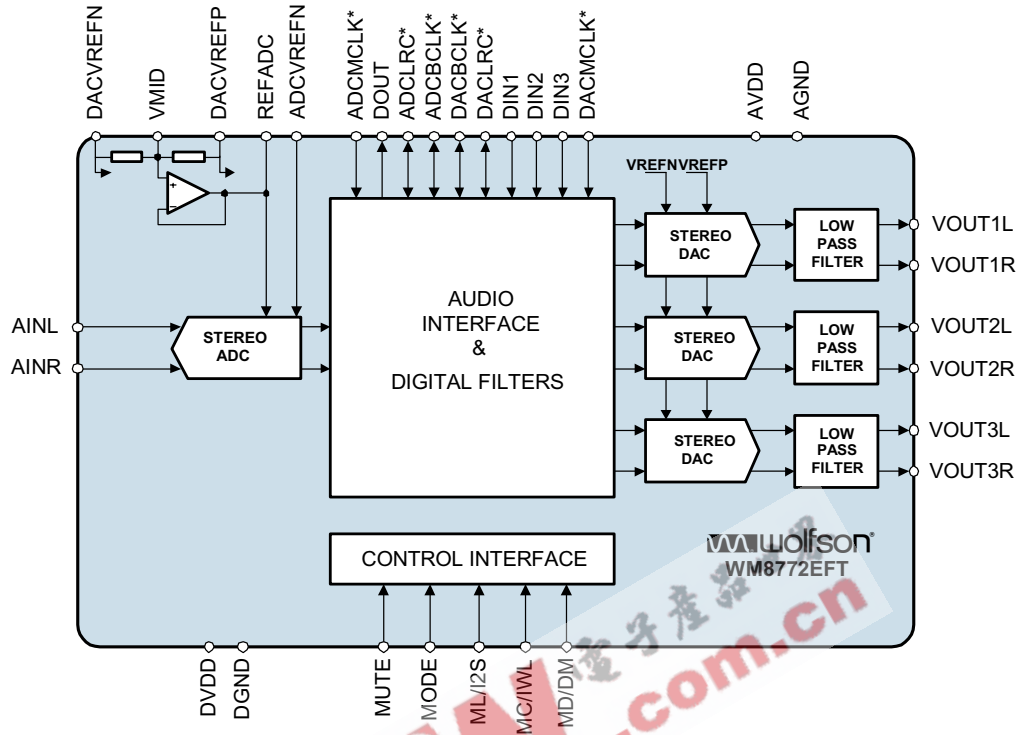

\* extra pins on TQFP allow separate clocking of ADC and DAC

## TABLE OF CONTENTS

<b>DESCRIPTION .....</b>	<b>1</b>
<b>FEATURES.....</b>	<b>1</b>
<b>APPLICATIONS .....</b>	<b>1</b>
<b>BLOCK DIAGRAM - 28 PIN SSOP .....</b>	<b>1</b>
<b>BLOCK DIAGRAM – 32 PIN TQFP.....</b>	<b>2</b>
<b>TABLE OF CONTENTS .....</b>	<b>3</b>
<b>PIN CONFIGURATION - 28 LEAD SSOP .....</b>	<b>5</b>
<b>ORDERING INFORMATION .....</b>	<b>5</b>
<b>PIN CONFIGURATION 32 LEAD TQFP.....</b>	<b>6</b>
<b>ORDERING INFORMATION .....</b>	<b>6</b>
<b>PIN DESCRIPTION – 28 LEAD SSOP .....</b>	<b>7</b>
<b>PIN DESCRIPTION – 32 LEAD TQFP .....</b>	<b>8</b>
<b>ABSOLUTE MAXIMUM RATINGS.....</b>	<b>9</b>
<b>RECOMMENDED OPERATING CONDITIONS .....</b>	<b>10</b>
ADC HIGH PASS FILTER .....	14
DIGITAL DE-EMPHASIS CHARACTERISTICS.....	14
<b>WM8772EDS – 28 PIN SSOP .....</b>	<b>16</b>
MASTER CLOCK TIMING.....	16
DIGITAL AUDIO INTERFACE – MASTER MODE .....	16
MPU INTERFACE TIMING.....	19
INTRODUCTION.....	20
AUDIO DATA SAMPLING RATES.....	20
HARDWARE CONTROL MODES .....	21
DIGITAL AUDIO INTERFACE .....	23
POWERDOWN MODES .....	27
ZERO DETECT .....	27
CONTROL INTERFACE REGISTERS .....	29
RECOMMENDED EXTERNAL COMPONENTS.....	37
SUGGESTED ANALOGUE LOW PASS POST DAC FILTERS .....	38
<b>WM8722EFT - 32 PIN TQFP .....</b>	<b>41</b>
MASTER CLOCK TIMING.....	41
DIGITAL AUDIO INTERFACE – MASTER MODE .....	41
MPU INTERFACE TIMING.....	44
<b>DEVICE DESCRIPTION .....</b>	<b>46</b>
INTRODUCTION.....	46
AUDIO DATA SAMPLING RATES.....	46
HARDWARE CONTROL MODES .....	47
DIGITAL AUDIO INTERFACE .....	49
POWERDOWN MODES .....	54
ZERO DETECT .....	54
<b>SOFTWARE CONTROL INTERFACE OPERATION .....</b>	<b>54</b>
<b>REGISTER MAP – 32 PIN TQFP .....</b>	<b>55</b>
CONTROL INTERFACE REGISTERS .....	56

---

<b>APPLICATIONS INFORMATION .....</b>	<b>66</b>
RECOMMENDED EXTERNAL COMPONENTS .....	66
<b>SUGGESTED ANALOGUE LOW PASS POST DAC FILTERS.....</b>	<b>67</b>
<b>PACKAGE DIMENSIONS .....</b>	<b>69</b>
<b>IMPORTANT NOTICE .....</b>	<b>70</b>
ADDRESS: .....	70



## PIN CONFIGURATION - 28 LEAD SSOP

MODE	<input type="checkbox"/>	1 ●	28	<input type="checkbox"/>	AVDD
MCLK	<input type="checkbox"/>	2	27	<input type="checkbox"/>	AGND
BCLK	<input type="checkbox"/>	3	26	<input type="checkbox"/>	VOUT3R
LRC	<input type="checkbox"/>	4	25	<input type="checkbox"/>	VOUT3L
DVDD	<input type="checkbox"/>	5	24	<input type="checkbox"/>	VOUT2R
DGND	<input type="checkbox"/>	6	23	<input type="checkbox"/>	VOUT2L
DIN1	<input type="checkbox"/>	7	22	<input type="checkbox"/>	VOUT1R
DIN2	<input type="checkbox"/>	8	21	<input type="checkbox"/>	VOUT1L
DIN3	<input type="checkbox"/>	9	20	<input type="checkbox"/>	AINL
DOUT	<input type="checkbox"/>	10	19	<input type="checkbox"/>	AINR
ML/I2S	<input type="checkbox"/>	11	18	<input type="checkbox"/>	VMID
MC/IWL	<input type="checkbox"/>	12	17	<input type="checkbox"/>	VREFP
MD/DM	<input type="checkbox"/>	13	16	<input type="checkbox"/>	VREFN
MUTE	<input type="checkbox"/>	14	15	<input type="checkbox"/>	REFADC

## ORDERING INFORMATION

DEVICE	TEMPERATURE RANGE	PACKAGE	MOISTURE SENSITIVITY LEVEL	PEAK SOLDERING TEMPERATURE
WM8772EDS	-25 to +85°C	28-pin SSOP	MSL1	260°C
WM8772EDS/R	-25 to +85°C	28-pin SSOP (tape and reel)	MSL1	260°C
WM8772SEDS/V	-25 to +85°C	28-pin SSOP (lead free)	MSL2	260°C
WM8772SEDS/RV	-25 to +85°C	28-pin SSOP (lead free, tape and reel)	MSL2	260°C

**Note:**

Reel quantity = 2,000

## PIN CONFIGURATION 32 LEAD TQFP

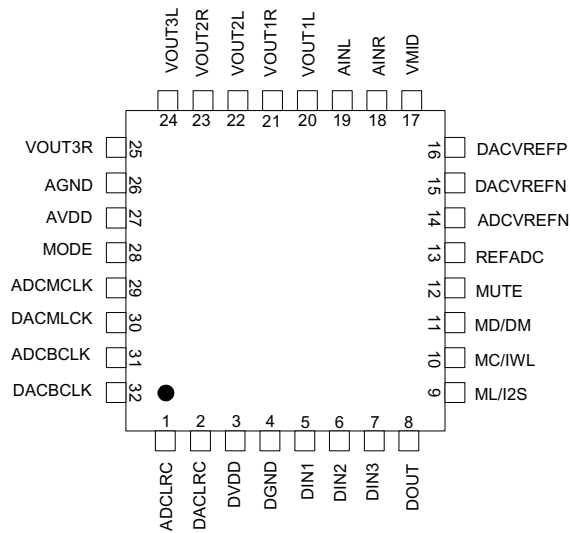

## ORDERING INFORMATION

DEVICE	TEMPERATURE RANGE	PACKAGE	MOISTURE SENSITIVITY LEVEL	PEAK SOLDERING TEMPERATURE
WM8772EFT	-25 to +85°C	32-lead TQFP	MSL1	240°C
WM8772SEFT/V	-25 to +85°C	32-lead TQFP (lead free)	MSL2	260°C
WM8772EFT/R	-25 to +85°C	32-lead TQFP (tape and reel)	MSL1	240°C
WM8772SEFT/RV	-25 to +85°C	32-lead TQFP (lead free, tape and reel)	MSL2	260°C

**Note:**

Reel quantity = 2,200

## PIN DESCRIPTION – 28 LEAD SSOP

PIN	NAME	TYPE	DESCRIPTION
1	MODE	Digital input	Control format selection 0 = Software control 1 = Hardware control
2	MCLK	Digital input	Master clock; 256, 384, 512 or 768fs (fs = word clock frequency) (combined ADCMCLK and DACMCLK)
3	BCLK	Digital input/output	Audio interface bit clock (combined ADCBCLK and DACBCLK)
4	LRC	Digital input/output	Audio left/right word clock (combined ADCLRC and DACLRC)
5	DVDD	Supply	Digital positive supply
6	DGND	Supply	Digital negative supply
7	DIN1	Digital input	DAC channel 1 data input
8	DIN2	Digital input	DAC channel 2 data input
9	DIN3	Digital input	DAC channel 3 data input
10	DOUT	Digital output	ADC data output
11	ML/2S	Digital input	Software Mode: Serial interface Latch signal Hardware Mode: Input Audio Data Format
12	MC/IWL	Digital input	Software Mode: Serial control interface clock Hardware Mode: Audio data input word length
13	MD/DM	Digital input	Software Mode: Serial interface data Hardware Mode: De-emphasis selection
14	MUTE	Digital input/output	DAC Zero Flag output or DAC mute input
15	REFADC	Analogue output	ADC reference buffer decoupling pin; 10uF external decoupling
16	VREFN	Supply	ADC and DAC negative supply
17	VREFP	Supply	DAC positive reference supply
18	VMID	Analogue output	Midrail divider decoupling pin; 10uF external decoupling
19	AINR	Analogue input	ADC right input
20	AINL	Analogue input	ADC left input
21	VOUT1L	Analogue output	DAC channel 1 left output
22	VOUT1R	Analogue output	DAC channel 1 right output
23	VOUT2L	Analogue output	DAC channel 2 left output
24	VOUT2R	Analogue output	DAC channel 2 right output
25	VOUT3L	Analogue output	DAC channel 3 left output
26	VOUT3R	Analogue output	DAC channel 3 right output
27	AGND	Supply	Analogue negative supply and substrate connection
28	AVDD	Supply	Analogue positive supply

**Note:** Digital input pins have Schmitt trigger input buffers.

## PIN DESCRIPTION – 32 LEAD TQFP

PIN	NAME	TYPE	DESCRIPTION
1	ADCLRC	Digital Input/Output	ADC left/right word clock
2	DACLRC	Digital Input/Output	DAC left/right word clock
3	DVDD	Supply	Digital positive supply
4	DGND	Supply	Digital negative supply
5	DIN1	Digital Input	DAC channel 1 data input
6	DIN2	Digital Input	DAC channel 2 data input
7	DIN3	Digital Input	DAC channel 3 data input
8	DOUT	Digital Output	ADC data output
9	ML/I2S	Digital Input	Software Mode: Serial interface Latch signal Hardware Mode: Input Audio Data Format
10	MC/IWL	Digital Input	Software Mode: Serial control interface clock Hardware Mode: Audio data input word length
11	MD/DM	Digital Input	Software Mode: Serial interface data Hardware Mode: De-emphasis selection
12	MUTE	Digital Input/Output	DAC Zero Flag output or DAC Mute Input
13	REFADC	Analogue Output	ADC reference buffer decoupling pin; 10uF external decoupling
14	ADCVREFN	Supply	ADC negative supply
15	DACVREFN	Supply	DAC negative supply
16	DACVREFP	Supply	DAC positive reference supply
17	VMID	Analogue Output	Midrail divider decoupling pin; 10uF external decoupling
18	AINR	Analogue Input	ADC right input
19	AINL	Analogue Input	ADC left input
20	VOUT1L	Analogue Output	DAC channel 1 left output
21	VOUT1R	Analogue Output	DAC channel 1 right output
22	VOUT2L	Analogue Output	DAC channel 2 left output
23	VOUT2R	Analogue Output	DAC channel 2 right output
24	VOUT3L	Analogue Output	DAC channel 3 left output
25	VOUT3R	Analogue Output	DAC channel 3 right output
26	AGND	Supply	Analogue negative supply and substrate connection
27	AVDD	Supply	Analogue positive supply
28	MODE	Digital Input	Control format selection 0 = Software control 1 = Hardware control
29	ADCMCLK	Digital Input	Master ADC clock; 256, 384, 512 or 768fs (fs = word clock frequency)
30	DACMCLK	Digital Input	Master DAC clock; 256, 384, 512 or 768fs (fs = word clock frequency)
31	ADCBCLK	Digital Input/Output	ADC audio interface bit clock
32	DACBCLK	Digital Input/Output	DAC audio interface bit clock

**Note:** Digital input pins have Schmitt trigger input buffers.



## ABSOLUTE MAXIMUM RATINGS

Absolute Maximum Ratings are stress ratings only. Permanent damage to the device may be caused by continuously operating at or beyond these limits. Device functional operating limits and guaranteed performance specifications are given under Electrical Characteristics at the test conditions specified.



ESD Sensitive Device. This device is manufactured on a CMOS process. It is therefore generically susceptible to damage from excessive static voltages. Proper ESD precautions must be taken during handling and storage of this device.

Wolfson tests its package types according to IPC/JEDEC J-STD-020B for Moisture Sensitivity to determine acceptable storage conditions prior to surface mount assembly. These levels are:

MSL1 = unlimited floor life at <30°C / 85% Relative Humidity. Not normally stored in moisture barrier bag.

MSL2 = out of bag storage for 1 year at <30°C / 60% Relative Humidity. Supplied in moisture barrier bag.

MSL3 = out of bag storage for 168 hours at <30°C / 60% Relative Humidity. Supplied in moisture barrier bag.

The Moisture Sensitivity Level for each package type is specified in Ordering Information.

CONDITION	MIN	MAX
Digital supply voltage	-0.3V	+5V
Analogue supply voltage	-0.3V	+7V
Voltage range digital inputs <sup>1</sup>	DGND -0.3V	DVDD +0.3V
Voltage range analogue inputs <sup>1</sup>	AGND -0.3V	AVDD +0.3V
Master Clock Frequency		37MHz
Operating temperature range, T <sub>A</sub>	-25°C	+85°C
Storage temperature after soldering	-65°C	+150°C
Package body temperature (soldering 10 seconds)		Refer to Ordering Information, p5 and p6
Package body temperature (soldering 2 minutes)		+183°C

### Notes:

1. Analogue and digital grounds must always be within 0.3V of each other.

## RECOMMENDED OPERATING CONDITIONS

PARAMETER	SYMBOL	TEST CONDITIONS	MIN	TYP	MAX	UNIT
Digital supply range	DVDD		2.7		3.6	V
Analogue supply range	AVDD, VREFP		2.7		5.5	V
Ground	AGND, VREFN, DGND			0		V
Difference DGND to AGND			-0.3	0	+0.3	V

**Note:** Digital supply DVDD must never be more than 0.3V greater than AVDD.

## ELECTRICAL CHARACTERISTICS

## Test Conditions

AVDD, VREFP = 5V, DVDD = 3.3V, AGND, VREFN = 0V, DGND = 0V,  $T_A = +25^\circ\text{C}$ ,  $f_s = 48\text{kHz}$ , MCLK = 256fs, 32-pin TQFP version unless otherwise stated. ADC/DAC in Slave Mode unless otherwise stated.

PARAMETER	SYMBOL	TEST CONDITIONS	MIN	TYP	MAX	UNIT
<b>DAC Performance (Load = 10k<math>\Omega</math>, 50pF)</b>						
0dBfs Full scale output voltage				1.0 x VREFP/5		V <sub>rms</sub>
SNR (Note 1,2,4)		A-weighted, @ $f_s = 48\text{kHz}$	95	103		dB
SNR (Note 1,2,4)		A-weighted @ $f_s = 96\text{kHz}$		102		dB
SNR (Note 1,2,4)		A-weighted @ $f_s = 192\text{kHz}$		101		dB
SNR (Note 1,2,4)		A-weighted @ $f_s = 48\text{kHz}$ , AVDD = 3.3V		99		dB
SNR (Note 1,2,4)		A-weighted @ $f_s = 96\text{kHz}$ , AVDD = 3.3V		99		dB
Dynamic Range (Note 2,4)	DNR	A-weighted, -60dB full scale input	90	103		dB
Total Harmonic Distortion (THD)		1kHz, 0dB.Fs		-90	-80	dB
Mute Attenuation		1kHz Input, 0dB gain		100		dB
DAC channel separation				100		dB
Power Supply Rejection Ratio	PSRR	1kHz 100mV <sub>p-p</sub>		50		dB
		20Hz to 20kHz 100mV <sub>p-p</sub>		45		dB

**Test Conditions**

AVDD, VREFP = 5V, DVDD = 3.3V, AGND, VREFN = 0V, DGND = 0V, T<sub>A</sub> = +25°C, fs = 48kHz, MCLK = 256fs, 32-pin TQFP version unless otherwise stated. ADC/DAC in Slave Mode unless otherwise stated.

PARAMETER	SYMBOL	TEST CONDITIONS	MIN	TYP	MAX	UNIT
<b>ADC Performance</b>						
Input Signal Level (0dB)				2.0 x REFADC/5		V <sub>rms</sub>
Input resistance				20		kΩ
Input capacitance				10		pF
SNR (Note 1,2,4)		A-weighted, 0dB gain @ fs = 48kHz	80	100		dB
SNR (Note 1,2,4)		A-weighted, 0dB gain @ fs = 96kHz 64 x OSR		100		dB
SNR (Note 1,2,4)		A-weighted, 0dB gain @ fs = 48kHz, AVDD = 3.3V		93		dB
SNR (Note 1,2,4)		A-weighted, 0dB gain @ fs = 96kHz, AVDD = 3.3V 64 x OSR		93		dB
Total Harmonic Distortion (THD)		kHz, 0dBFS		-80		dB
		1kHz, -1dBFS		-82		dB
ADC Channel Separation		1kHz Input		90		dB
Mute Attenuation		1kHz Input, 0dB gain		90		dB
Power Supply Rejection Ratio	PSRR	1kHz 100mVpp		50		dB
		20Hz to 20kHz 100mVpp		45		dB
<b>Digital Logic Levels (CMOS Levels)</b>						
Input LOW level	V <sub>IL</sub>				0.3 x DVDD	V
Input HIGH level	V <sub>IH</sub>		0.7 x DVDD			V
Input leakage current				±0.2	±1	μA
Input capacitance				5		pF
Output LOW	V <sub>OL</sub>	I <sub>OL</sub> =1mA			0.1 x DVDD	V
Output HIGH	V <sub>OH</sub>	I <sub>OH</sub> =-1mA	0.9 x DVDD			V
<b>Analogue Reference Levels</b>						
Reference voltage	V <sub>VMID</sub>		VREFP/2 – 50mV	VREFP/2	VREFP/2 + 50mV	V
Potential divider resistance	R <sub>VMID</sub>	VREFP to VMID and VMID to VREFN		50		kΩ
<b>Supply Current</b>						
Analogue supply current		AVDD, VREFP = 5V		45		mA
Digital supply current		DVDD = 3.3V		16		mA

**Notes:**

- Ratio of output level with 1kHz full scale input, to the output level with all zeros into the digital input, measured 'A' weighted.
- All performance measurements done with 20kHz low pass filter, and where noted an A-weight filter. Failure to use such a filter will result in higher THD+N and lower SNR and Dynamic Range readings than are found in the Electrical Characteristics. The low pass filter removes out of band noise; although it is not audible it may affect dynamic specification values.
- VMID decoupled with 10μF and 0.1μF capacitors (smaller values may result in reduced performance).

## TERMINOLOGY

1. Signal-to-noise ratio (dB) - SNR is a measure of the difference in level between the full scale output and the output with no signal applied. (No Auto-zero or Automute function is employed in achieving these results).
2. Dynamic range (dB) - DNR is a measure of the difference between the highest and lowest portions of a signal. Normally a THD+N measurement at 60dB below full scale. The measured signal is then corrected by adding the 60dB to it. (e.g. THD+N @ -60dB= -32dB, DR= 92dB).
3. THD+N (dB) - THD+N is a ratio, of the rms values, of (Noise + Distortion)/Signal.
4. Stop band attenuation (dB) - Is the degree to which the frequency spectrum is attenuated (outside audio band).
5. Channel Separation (dB) - Also known as Cross-Talk. This is a measure of the amount one channel is isolated from the other. Normally measured by sending a full scale signal down one channel and measuring the other.
6. Pass-Band Ripple - Any variation of the frequency response in the pass-band region.

EEPW 电子產品世界  
.com.cn

### DIGITAL FILTER CHARACTERISTICS

PARAMETER	TEST CONDITIONS	MIN	TYP	MAX	UNIT
ADC Filter					
Passband	$\pm 0.01$ dB	0		0.4535fs	
	-6dB		0.5fs		
Passband ripple				$\pm 0.01$	dB
Stopband		0.5465fs			
Stopband Attenuation	$f > 0.5465fs$	-65			dB
DAC Filter					
Passband	$\pm 0.05$ dB			0.444fs	
	-3dB		0.487fs		
Passband ripple				$\pm 0.05$	dB
Stopband		0.555fs			
Stopband Attenuation	$f > 0.555fs$	-60			dB

Table 1 Digital Filter Characteristics

### DAC FILTER RESPONSES

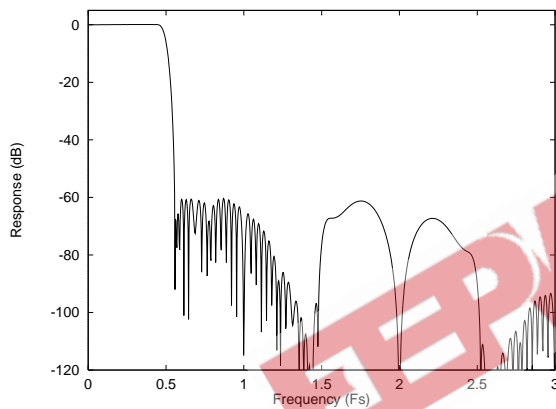

Figure 1 DAC Digital Filter Frequency Response – 44.1, 48 and 96KHz

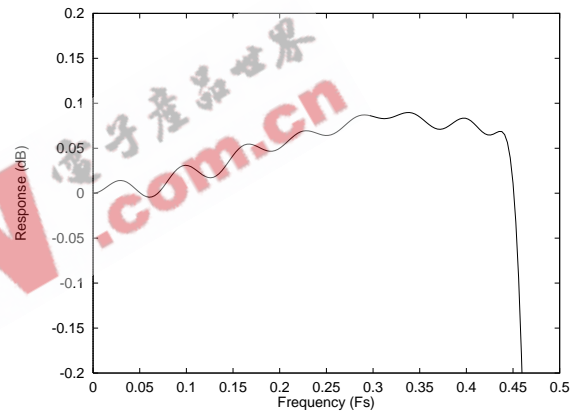

Figure 2 DAC Digital Filter Ripple –44.1, 48 and 96KHz

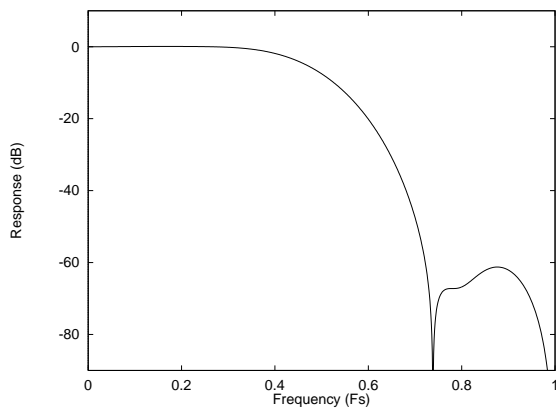

Figure 3 DAC Digital Filter Frequency Response – 192KHz

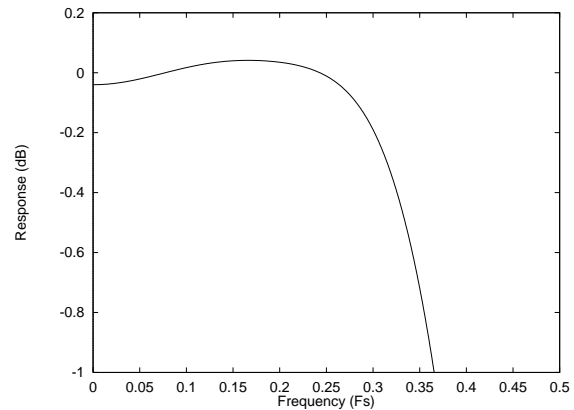

Figure 4 DAC Digital Filter Ripple – 192kHz

**ADC FILTER RESPONSES**

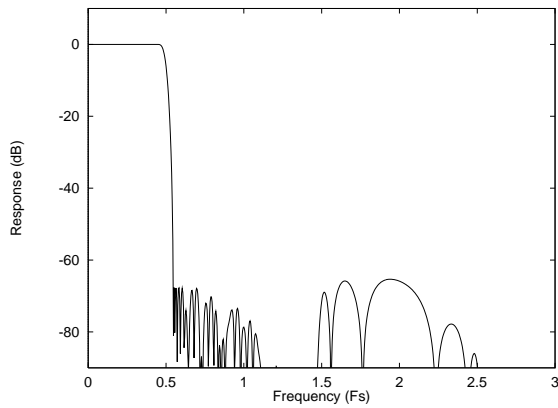

Figure 5 ADC Digital Filter Frequency Response

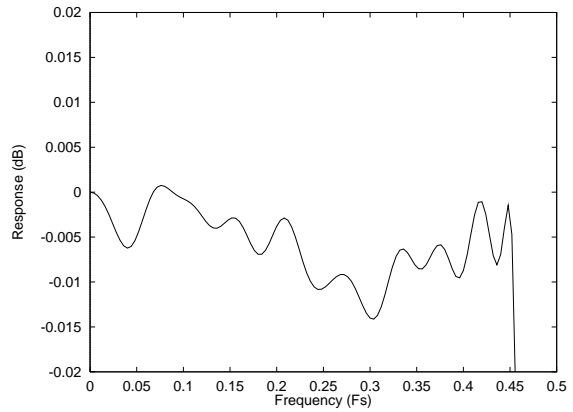

Figure 6 ADC Digital Filter Ripple

**ADC HIGH PASS FILTER**

The WM8772EDS has a selectable digital high pass filter to remove DC offsets. The filter response is characterised by the following polynomial.

$$H(z) = \frac{1 - z^{-1}}{1 - 0.9995z^{-1}}$$

**DIGITAL DE-EMPHASIS CHARACTERISTICS**

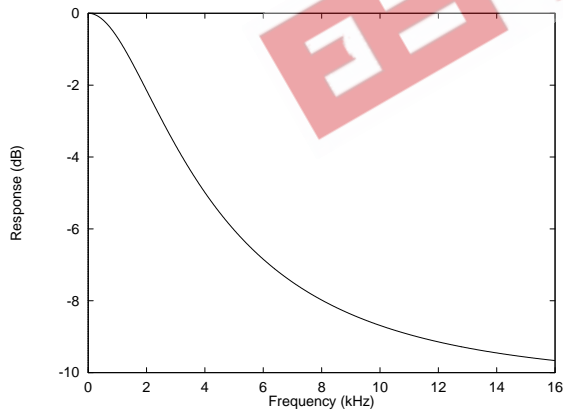

Figure 7 De-Emphasis Frequency Response (32kHz)

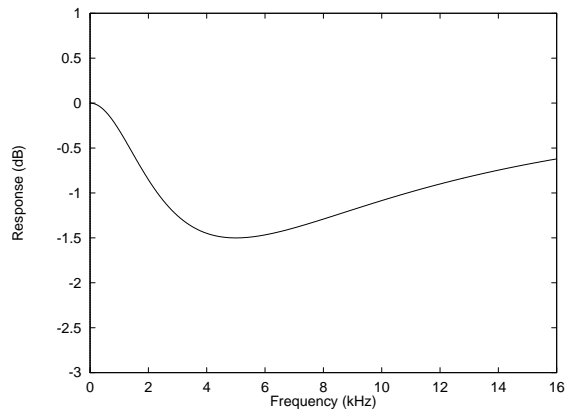

Figure 8 De-Emphasis Error (32kHz)

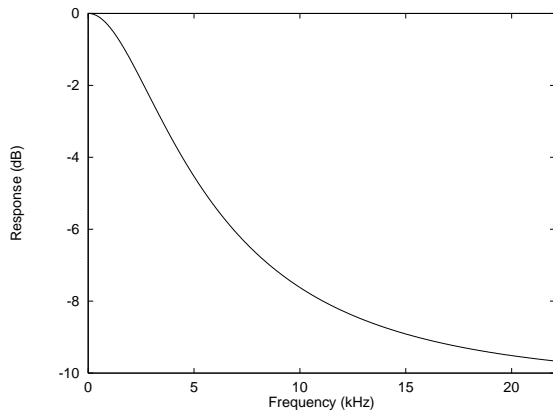

Figure 9 De-Emphasis Frequency Response (44.1KHz)

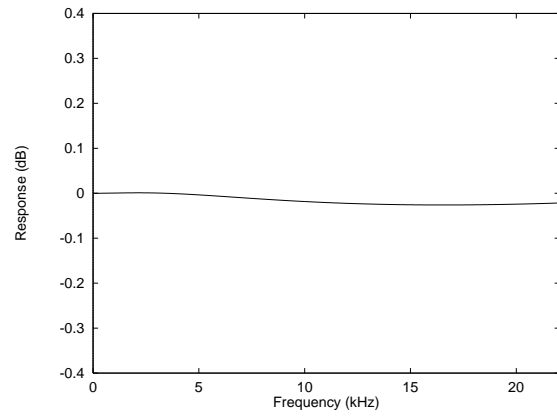

Figure 10 De-Emphasis Error (44.1KHz)

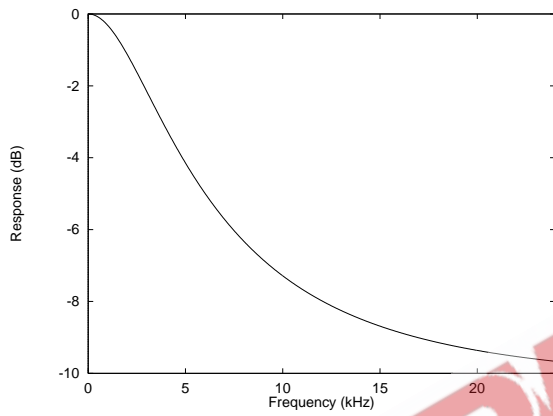

Figure 11 De-Emphasis Frequency Response (48kHz)

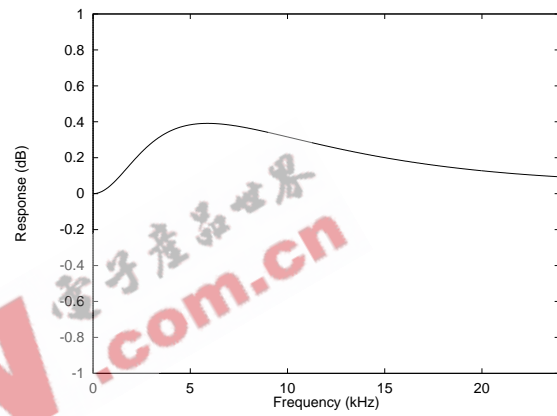

Figure 12 De-Emphasis Error (48kHz)

PAGES 12 TO 36 DESCRIBE THE OPERATION OF THE WM8772EDS 28 PIN SSOP PRODUCT VARIANT.

PAGES 37 TO 66 DESCRIBE THE OPERATION OF THE WM8772EFT 32 PIN TQFP PRODUCT VARIANT.

WM8772EDS – 28 PIN SSOP

MASTER CLOCK TIMING

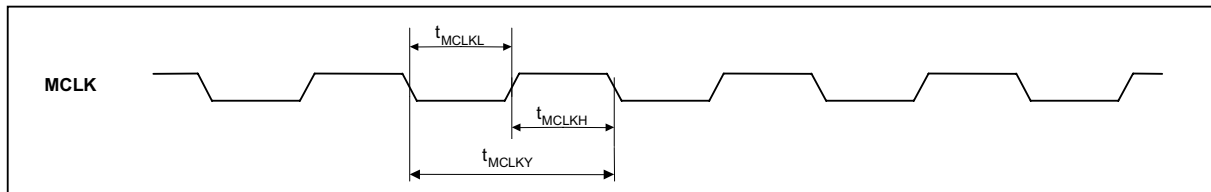

Figure 13 ADC and DAC Master Clock Timing Requirements

Test Conditions

AVDD, VREFP = 5V, DVDD = 3.3V, AGND, VREFN = 0V, AGND, DGND = 0V,  $T_A = +25^\circ\text{C}$ ,  $f_s = 48\text{kHz}$ , DACMCLK and ADCMCLK = 256fs unless otherwise stated.

PARAMETER	SYMBOL	TEST CONDITIONS	MIN	TYP	MAX	UNIT
<b>System Clock Timing Information</b>						
MCLK System clock pulse width high	$t_{MCLKH}$		11			ns
MCLK System clock pulse width low	$t_{MCLKL}$		11			ns
MCLK System clock cycle time	$t_{MCLKY}$		28			ns
MCLK Duty cycle			40:60		60:40	

Table 2 Master Clock Timing Requirements

DIGITAL AUDIO INTERFACE – MASTER MODE

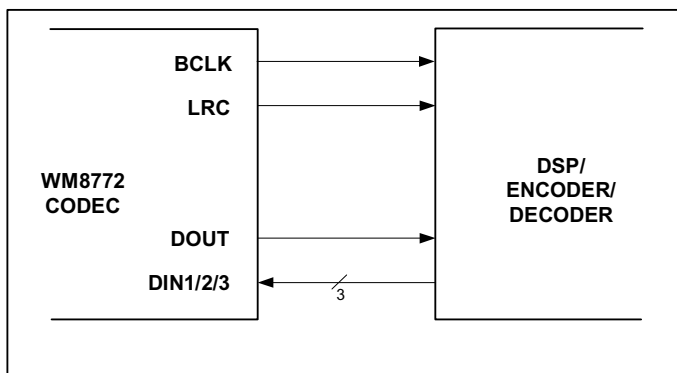

Figure 14 Audio Interface - Master Mode



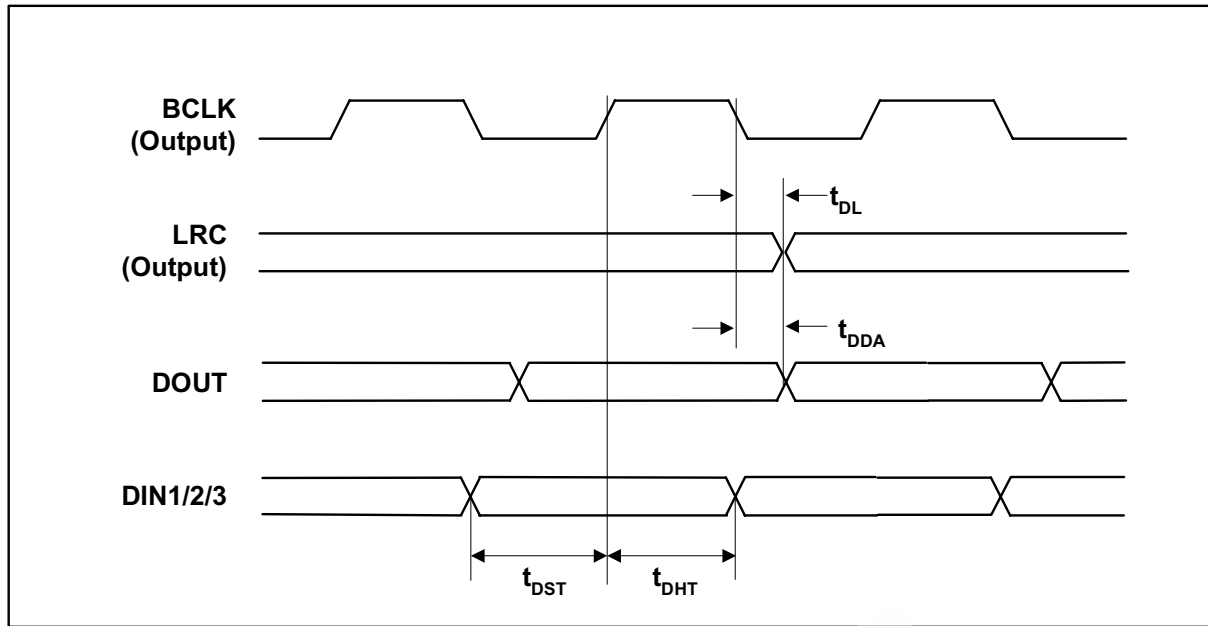

Figure 15 Digital Audio Data Timing – Master Mode

**Test Conditions**

AVDD, VREFP = 5V, DVDD = 3.3V, AGND, VREFN, DGND = 0V, T<sub>A</sub> = +25°C, Master Mode, f<sub>s</sub> = 48kHz, MCLK = 256fs unless otherwise stated.

PARAMETER	SYMBOL	TEST CONDITIONS	MIN	TYP	MAX	UNIT
<b>Audio Data Input Timing Information</b>						
LRC propagation delay from BCLK falling edge	t <sub>DL</sub>		0		10	ns
DOUT propagation delay from BCLK falling edge	t <sub>DDA</sub>		0		10	ns
DIN1/2/3 setup time to BCLK rising edge	t <sub>DST</sub>		10			ns
DIN1/2/3 hold time from BCLK rising edge	t <sub>DHT</sub>		10			ns

Table 3 Digital Audio Data Timing – Master Mode

DIGITAL AUDIO INTERFACE – SLAVE MODE

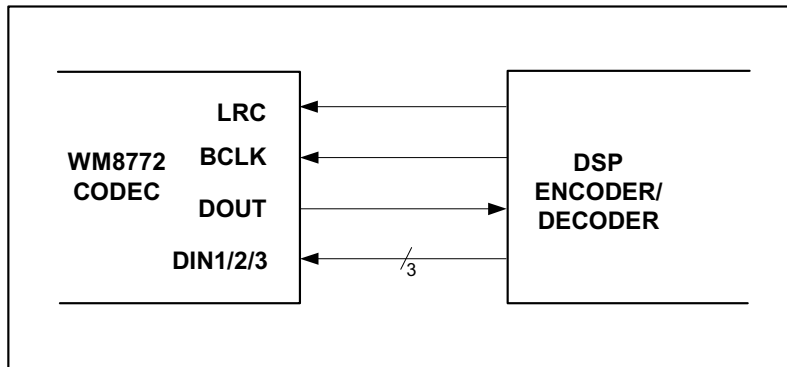

Figure 16 Audio Interface – Slave Mode

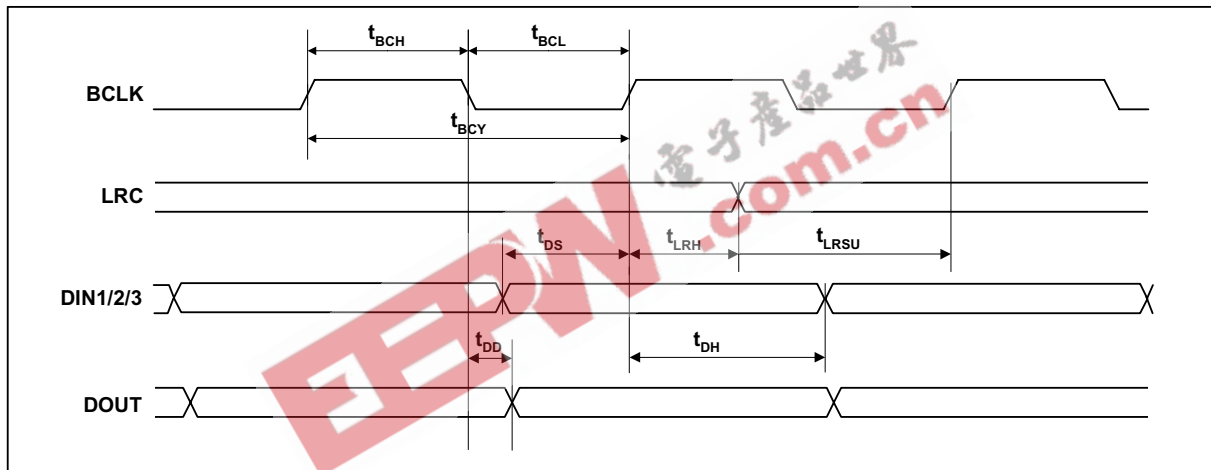

Figure 17 Digital Audio Data Timing – Slave Mode

Test Conditions

AVDD = 5V, DVDD = 3.3V, AGND = 0V, DGND = 0V, T<sub>A</sub> = +25°C, Slave Mode, fs = 48kHz, MCLK = 256fs unless otherwise stated.

PARAMETER	SYMBOL	TEST CONDITIONS	MIN	TYP	MAX	UNIT
<b>Audio Data Input Timing Information</b>						
BCLK cycle time	t <sub>BCY</sub>		50			ns
BCLK pulse width high	t <sub>BCH</sub>		20			ns
BCLK pulse width low	t <sub>BCL</sub>		20			ns
LRC set-up time to BCLK rising edge	t <sub>LRSU</sub>		10			ns
LRC hold time from BCLK rising edge	t <sub>LRH</sub>		10			ns
DIN1/2/3 set-up time to BCLK rising edge	t <sub>DS</sub>		10			ns
DIN1/2/3 hold time from BCLK rising edge	t <sub>DH</sub>		10			ns

**Test Conditions**

AVDD = 5V, DVDD = 3.3V, AGND = 0V, DGND = 0V,  $T_A$  = +25°C, Slave Mode,  $f_s$  = 48kHz, MCLK = 256fs unless otherwise stated.

PARAMETER	SYMBOL	TEST CONDITIONS	MIN	TYP	MAX	UNIT
DOUT propagation delay from BCLK falling edge	$t_{DD}$		0		10	ns

Table 4 Digital Audio Data Timing – Slave Mode

**MPU INTERFACE TIMING**

Figure 18 SPI Compatible Control Interface Input Timing

**Test Conditions**

AVDD = 5V, DVDD = 3.3V, AGND, DGND = 0V,  $T_A$  = +25°C,  $f_s$  = 48kHz, DACMCLK and ADCMCLK = 256fs unless otherwise stated

PARAMETER	SYMBOL	MIN	TYP	MAX	UNIT
MC/IWL rising edge to ML/I2S rising edge	$t_{SCS}$	60			ns
MC/IWL pulse cycle time	$t_{SCY}$	80			ns
MC/IWL pulse width low	$t_{SCL}$	30			ns
MC/IWL pulse width high	$t_{SCH}$	30			ns
MD/DM to MC/IWL set-up time	$t_{DSU}$	20			ns
MC/IWL to MD/DM hold time	$t_{DHO}$	20			ns
ML/I2S pulse width low	$t_{CSL}$	20			ns
ML/I2S pulse width high	$t_{CSH}$	20			ns
ML/I2S rising to MC/IWL rising	$t_{CSS}$	20			ns

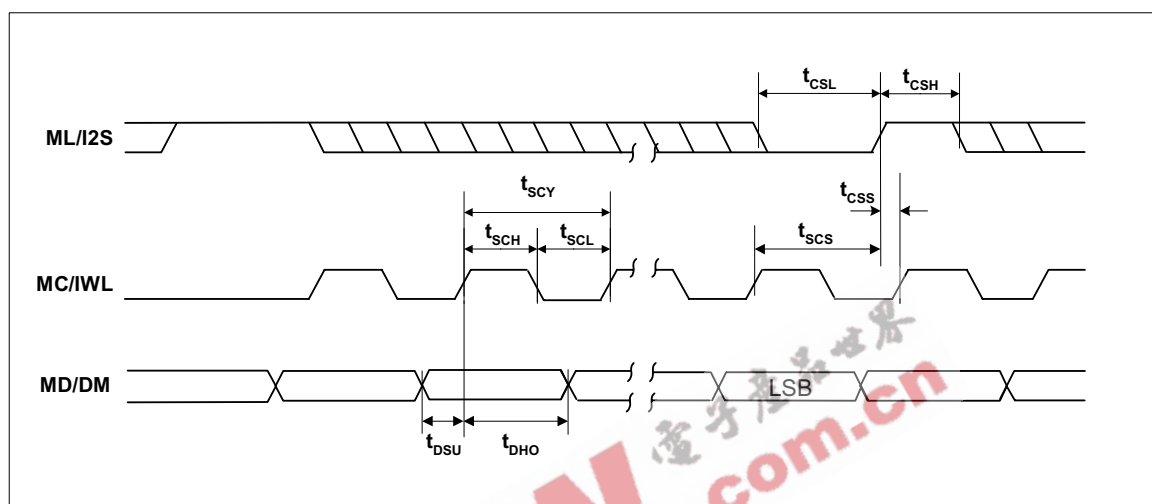
Table 5 3-Wire SPI Compatible Control Interface Input Timing Information

## DEVICE DESCRIPTION

### INTRODUCTION

WM8772EDS is a complete 6-channel DAC, 2-channel ADC audio codec, including digital interpolation and decimation filters, multi-bit sigma delta stereo ADC, and switched capacitor multi-bit sigma delta DACs with digital volume controls on each channel and output smoothing filters.

The device is implemented as three separate stereo DACs and a stereo ADC in a single package and controlled by a single interface.

Each stereo DAC has its own data input DIN1/2/3, the stereo ADC has its own data output DOUT. The word clock LRC, bit clock BCLK and master clock MCLK are shared between them.

The Audio Interface may be configured to operate in either master or slave mode. In Slave mode LRC and BCLK are all inputs. In Master mode LRC and BCLK are all outputs.

Each DAC has its own digital volume control that is adjustable in 0.5dB steps. The digital volume controls may be operated independently. In addition, a zero cross detect circuit is provided for each DAC for the digital volume controls. The digital volume control detects a transition through the zero point before updating the volume. This minimises audible clicks and 'zipper' noise as the gain values change.

Control of internal functionality of the device is by 3-wire serial or pin programmable control interface. The software control interface may be asynchronous to the audio data interface as control data will be re-synchronised to the audio processing internally.

Operation using master clocks of 128fs, 192fs, 256fs, 384fs, 512fs or 768fs is provided for the DAC, for operation of both the ADC and DAC master clocks of 256fs, 384fs, 512fs and 768fs is provided. In Slave mode selection between clock rates is automatically controlled. In master mode, the sample rate is set by control bits RATE. Audio sample rates (fs) from less than 8ks/s up to 192ks/s are allowed for the DAC and from less than 32ks/s up to 96ks/s for the ADC, provided the appropriate master clock is input.

The audio data interface supports right, left and I<sup>2</sup>S interface formats along with a highly flexible DSP serial port interface.

### AUDIO DATA SAMPLING RATES

In a typical digital audio system there is only one central clock source producing a reference clock to which all audio data processing is synchronised. This clock is often referred to as the audio system's Master Clock. The external master system clock can be applied directly through the MCLK input pin with no software configuration necessary. In a system where there are a number of possible sources for the reference clock it is recommended that the clock source with the lowest jitter be used to optimise the performance of the ADC and DAC.

The master clock for WM8772EDS supports audio sampling rates from 128fs to 768fs, where fs is the audio sampling frequency (LRC) typically 32kHz, 44.1kHz, 48kHz, 96kHz or 192kHz (for DAC operation only). For ADC operation sample rates from 256fs to 768fs are supported. The master clock is used to operate the digital filters and the noise shaping circuits.

In Slave mode the WM8772EDS has a master clock detection circuit that automatically determines the relationship between the system clock frequency and the sampling rate (to within +/- 32 master clocks). If there is a greater than 32 clocks error the interface defaults to 768fs mode. The master clocks must be synchronised with LRC, although the WM8772EDS is tolerant of phase variations or jitter on this clock. Table 6 shows the typical master clock frequency inputs for the WM8772EDS.

The signal processing for the WM8772EDS typically operates at an oversampling rate of 128fs for both ADC and DAC. The exception to this for the DAC is for operation with a 128/192fs system clock, e.g. for 192kHz operation, when the oversampling rate is 64fs. For ADC operation at 96kHz it is recommended that the user set the ADCOSR bit. This changes the ADC signal processing oversample rate to 64fs.

SAMPLING RATE (LRC)	System Clock Frequency (MHz)					
	128fs	192fs	256fs	384fs	512fs	768fs
32kHz	4.096	6.144	8.192	12.288	16.384	24.576
44.1kHz	5.6448	8.467	11.2896	16.9340	22.5792	33.8688
48kHz	6.144	9.216	12.288	18.432	24.576	36.864
96kHz	12.288	18.432	24.576	36.864	Unavailable	Unavailable
192kHz	24.576	36.864	Unavailable	Unavailable	Unavailable	Unavailable

**Table 6 System Clock Frequencies Versus Sampling Rate**  
(ADC does not support 128fs and 192fs)

## HARDWARE CONTROL MODES

When the MODE pin is held high, the following hardware modes of operation are available.

**Note:** When in hardware mode the ADC and DAC will only run in slave mode.

### MUTE AND AUTOMUTE OPERATION

In both hardware and software modes, MUTE controls the selection of MUTE directly, and can be used to enable and disable the automute function. This pin becomes an output when left floating and indicates infinite ZERO detect (IZD) has been detected.

	DESCRIPTION
0	Normal Operation
1	Mute DAC channels
Floating	Enable IZD, MUTE becomes an output to indicate when IZD occurs. L=IZD detected, H=IZD not detected.

**Table 7 Mute and Automute Control**

Figure 19 shows the application and release of MUTE whilst a full amplitude sinusoid is being played at 48kHz sampling rate. When MUTE (lower trace) is asserted, the output (upper trace) begins to decay exponentially from the DC level of the last input sample. The output will decay towards  $V_{MID}$  with a time constant of approximately 64 input samples. If MUTE is applied to all channels for 1024 or more input samples the outputs will be connected directly to  $V_{MID}$  if IZD is set. When MUTE is deasserted, the output will restart immediately from the current input sample.

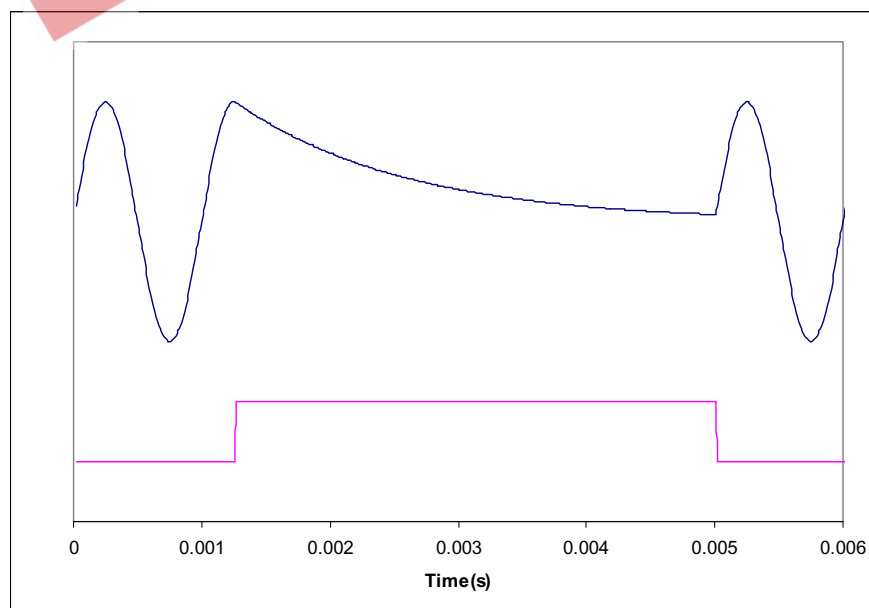

**Figure 19 Application and Release of Soft Mute**

The MUTE pin is an input to select mute or not mute. MUTE is active high; taking the pin high causes the filters to soft mute, ramping down the audio signal over a few milliseconds. Taking MUTE low again allows data into the filter.

The automute function detects a series of ZERO value audio samples of 1024 samples long being applied to both channels. After such an event, a latch is set whose output (AUTOMUTED) is wire OR'ed through a 10kΩ resistor to the MUTE pin. Thus if the MUTE pin is not being driven, the automute function will assert mute.

If MUTE is tied low, AUTOMUTED is overridden and will not mute unless the IZD register bit is set. If MUTE is driven from a bi-directional source, then both MUTE and automute functions are available. If MUTE is not driven, AUTOMUTED appears as a weak output (10kΩ source impedance) and can be used to drive external mute circuits. AUTOMUTED will be removed as soon as any channel receives a non-ZERO input.

A diagram showing how the various Mute modes interact is shown below Figure 20.

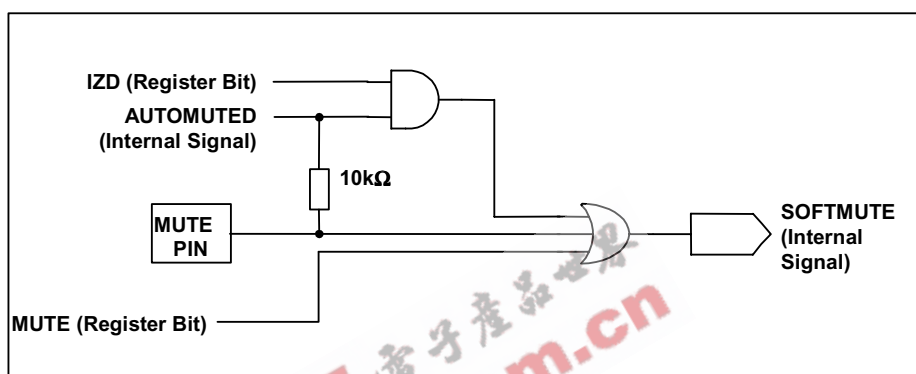

Figure 20 Selection Logic for MUTE Modes

**INPUT FORMAT SELECTION**

In hardware mode, ML/I2S and MC/IWL become input controls for selection of input data format type and input data word length for both the ADC and DAC.

ML/I2S	MC/IWL	INPUT DATA MODE
0	0	24-bit right justified
0	1	20-bit right justified
1	0	16-bit I <sup>2</sup> S
1	1	24-bit I <sup>2</sup> S

Table 8 Input Format Selection

**Note:**

In 24 bit I<sup>2</sup>S mode, any width of 24 bits or less is supported provided that the left/right clocks (LRC) are high for a minimum of 24 bit clocks (BCLK) and low for a minimum of 24 bit clocks.

**DE-EMPHASIS CONTROL**

In hardware mode, the MD/DM pin becomes an input control for selection of de-emphasis filtering to be applied.

MD/DM	DE-EMPHASIS
0	Off
1	On

Table 9 De-emphasis Control

## DIGITAL AUDIO INTERFACE

### MASTER AND SLAVE MODES

The audio interface operates in either Slave or Master mode, selectable using the MS control bit. In both Master and Slave modes DIN1/2/3 are always inputs to the WM8772EDS and DOUT is always an output. The default is Slave mode.

In Slave mode, LRC and BCLK are inputs to the WM8772EDS (Figure 21). DIN1/2/3 and LRC are sampled by the WM8772EDS on the rising edge of BCLK. ADC data is output on DOUT and changes on the falling edge of BCLK.

By setting the control bit BCP the polarity of BCLK may be reversed so that DIN1/2/3 and LRC are sampled on the falling edge of BCLK and DOUT changes on the rising edge of BCLK.

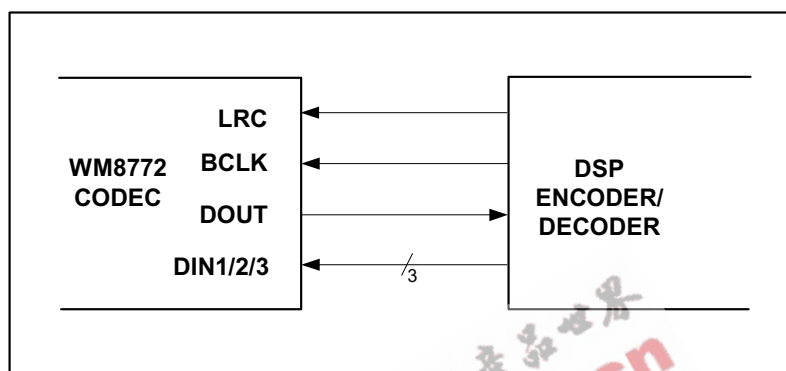

Figure 21 Slave Mode

In Master mode, LRC and BCLK are outputs from the WM8772EDS (Figure 22). LRC and BCLK are generated by the WM8772EDS. DIN1/2/3 are sampled by the WM8772EDS on the rising edge of BCLK so the controller must output DAC data that changes on the falling edge of BCLK. ADC data is output on DOUT and changes on the falling edge of BCLK.

By setting control bit BCP the polarity of BCLK may be reversed so that DIN1/2/3 are sampled on the falling edge of BCLK, and DOUT changes on the rising edge of BCLK.

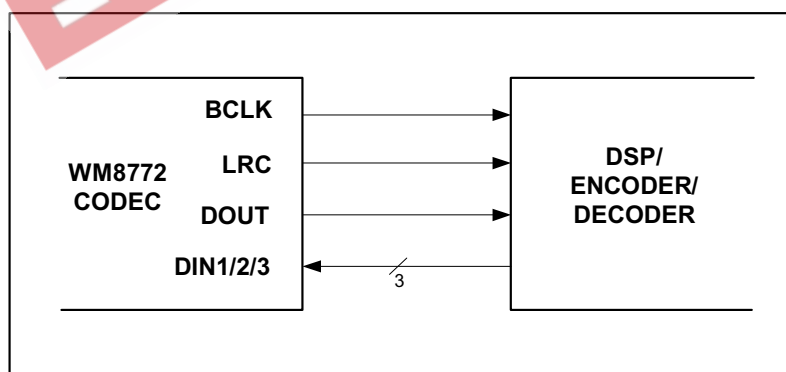

Figure 22 Master Mode

## AUDIO INTERFACE FORMATS

Audio data is applied to the internal DAC filters, or output from the ADC filters, via the Digital Audio Interface. 5 popular interface formats are supported:

- Left Justified mode
- Right Justified mode
- I<sup>2</sup>S mode
- DSP Early mode
- DSP Late mode

All 5 formats send the MSB first and support word lengths of 16, 20, 24 and 32 bits, with the exception of 32 bit right justified mode, which is not supported.

In left justified, right justified and I<sup>2</sup>S modes, the digital audio interface receives DAC data on the DIN1/2/3 inputs and outputs ADC data on DOUT. Audio Data for each stereo channel is time multiplexed with LRC indicating whether the left or right channel is present. LRC is also used as a timing reference to indicate the beginning or end of the data words.

In left justified, right justified and I<sup>2</sup>S modes, the minimum number of BCLKs per LRC period is 2 times the selected word length. LRC must be high for a minimum of word length BCLKs and low for a minimum of word length BCLKs. Any mark to space ratio on LRC is acceptable provided the above requirements are met.

In DSP early or DSP late mode, all 6 DAC channels are time multiplexed onto DIN1. LRC is used as a frame sync signal to identify the MSB of the first word. The minimum number of BCLKs per LRC period is 6 times the selected word length. Any mark to space ratio is acceptable on LRC provided the rising edge is correctly positioned. The ADC data may also be output in DSP early or late modes, with LRC used as a frame sync to identify the MSB of the first word. The minimum number of BCLKs per LRC period is 2 times the selected word length if only the ADC is being operated.

### LEFT JUSTIFIED MODE

In left justified mode, the MSB of DIN1/2/3 is sampled by the WM8772EDS on the first rising edge of BCLK following a LRC transition. The MSB of the ADC data is output on DOUT and changes on the same falling edge of BCLK as LRC and may be sampled on the rising edge of BCLK. LRC is high during the left samples and low during the right samples (Figure 23).

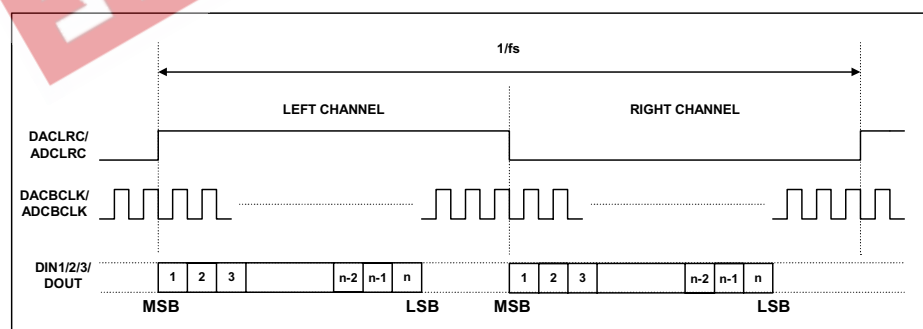

Figure 23 Left Justified Mode Timing Diagram



**RIGHT JUSTIFIED MODE**

In right justified mode, the LSB of DIN1/2/3 is sampled by the WM8772EDS on the rising edge of BCLK preceding a LRC transition. The LSB of the ADC data is output on DOUT and changes on the falling edge of BCLK preceding a LRC transition and may be sampled on the rising edge of BCLK. LRC are high during the left samples and low during the right samples (Figure 24).

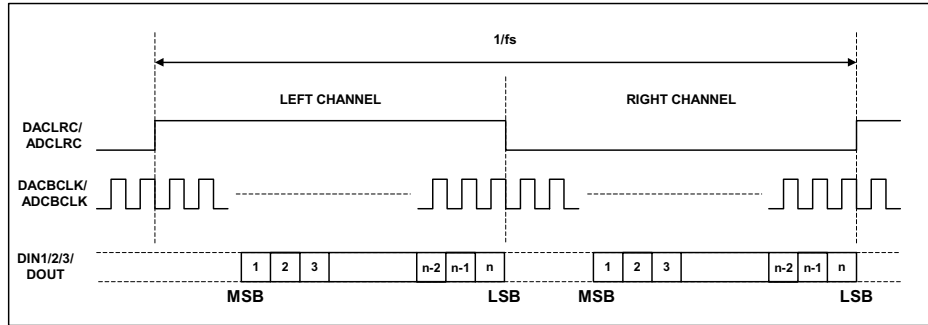

Figure 24 Right Justified Mode Timing Diagram

**I<sup>2</sup>S MODE**

In I<sup>2</sup>S mode, the MSB of DIN1/2/3 is sampled by the WM8772EDS on the second rising edge of BCLK following a LRC transition. The MSB of the ADC data is output on DOUT and changes on the first falling edge of BCLK following an LRC transition and may be sampled on the rising edge of BCLK. LRC are low during the left samples and high during the right samples.

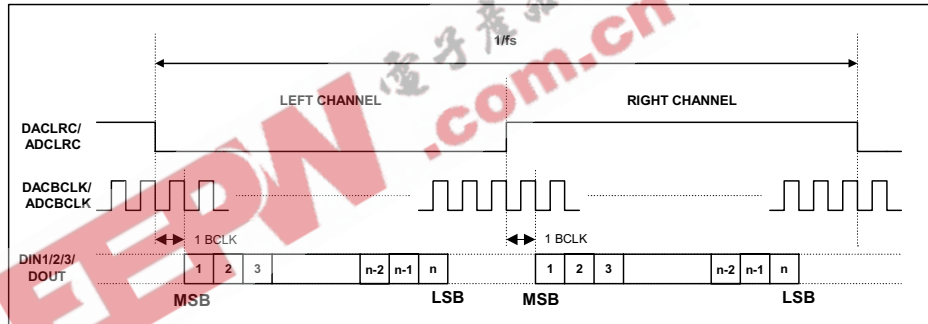

Figure 25 I<sup>2</sup>S Mode Timing Diagram

**DSP EARLY MODE**

In DSP early mode, the MSB of DAC channel 1 left data is sampled by the WM8772EDS on the second rising edge on BCLK following a LRC rising edge. DAC channel 1 right and DAC channels 2 and 3 data follow DAC channel 1 left data (Figure 26).

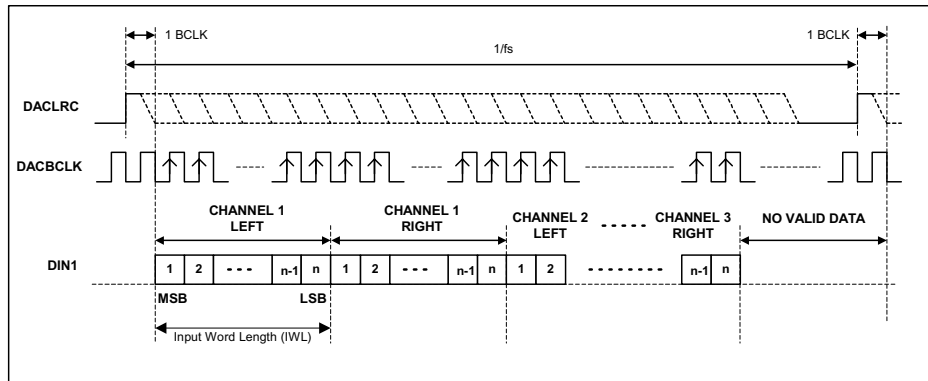

Figure 26 DSP Early Mode Timing Diagram – DAC Data Input

The MSB of the left channel ADC data is output on DOUT and changes on the first falling edge of BCLK following a low to high LRC transition and may be sampled on the rising edge of BCLK. The right channel ADC data is contiguous with the left channel data (Figure 27)

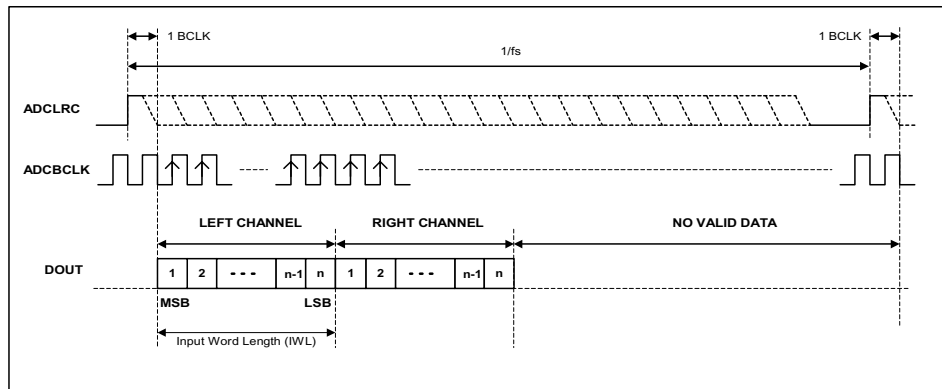

Figure 27 DSP Early Mode Timing Diagram – ADC Data Output

**DSP LATE MODE**

In DSP late mode, the MSB of DAC channel 1 left data is sampled by the WM8772EDS on the first BCLK rising edge following a LRC rising edge. DAC channel 1 right and DAC channels 2 and 3 data follow DAC channel 1 left data (Figure 28).

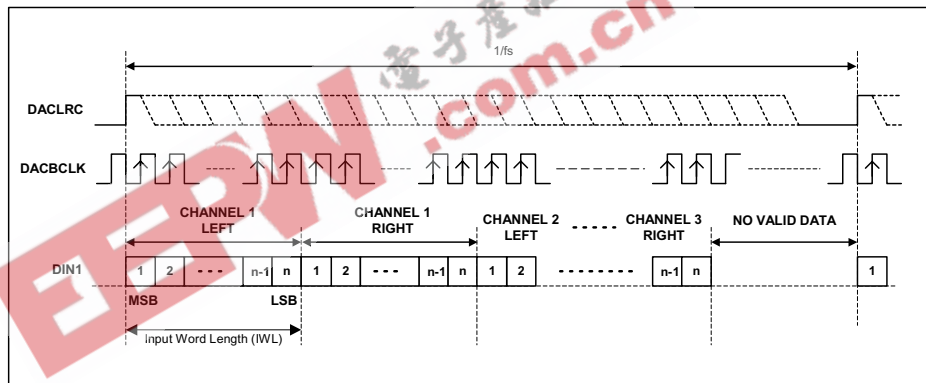

Figure 28 DSP Late Mode Timing Diagram – DAC Data Input

The MSB of the left channel ADC data is output on DOUT and changes on the same falling edge of BCLK as the low to high LRC transition and may be sampled on the rising edge of BCLK. The right channel ADC data is contiguous with the left channel data (Figure 29).

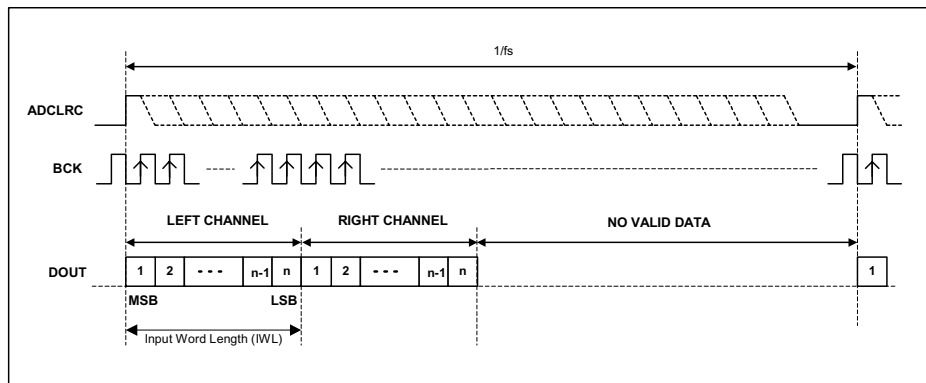

Figure 29 DSP Late Mode Timing Diagram – ADC Data Output

In both early and late DSP modes, DACL1 is always sent first, followed immediately by DACR1 and the data words for the other 6 channels. No BCLK edges are allowed between the data words. The word order is DAC1 left, DAC1 right, DAC2 left, DAC2 right, DAC3 left, DAC3 right.

## POWERDOWN MODES

The WM8772EDS has powerdown control bits allowing specific parts of the WM8772EDS to be powered off when not being used. Control bit ADCPD powers off the ADC. The three stereo DACs each have a separate powerdown control bit, DACPD[2:0] allowing individual stereo DACs to be powered off when not in use. Setting ADCPD and DACPD[2:0] will powerdown everything except the references VMID and REFADC. These may be powered down by setting PDWN. Setting PDWN will override all other powerdown control bits. It is recommended that the ADC and DACs are powered down before setting PDWN.

## ZERO DETECT

The WM8772EDS has a zero detect circuit for each DAC channel that detects when 1024 consecutive zero samples have been input. The MUTE pin output may be programmed to output the zero detect signal (see Table 10) which may then be used to control external muting circuits. A '1' on MUTE indicates a zero detect. The zero detect may also be used to automatically enable DAC mute by setting IZD.

DZFM[1:0]	MUTE
00	All channels zero
01	Channel 1 zero
10	Channel 2 zero
11	Channel 3 zero

Table 10 Zero Flag Output Select

## SOFTWARE CONTROL INTERFACE OPERATION

The WM8772EDS is controlled using a 3-wire serial interface in software mode or pin programmable in hardware mode.

The control mode is selected by the state of the MODE pin.

### 3-WIRE (SPI COMPATIBLE) SERIAL CONTROL MODE

MD/DM is used for the program data, MC/IWL is used to clock in the program data and ML/I2S is used to latch the program data. MD/DM is sampled on the rising edge of MC/IWL. The 3-wire interface protocol is shown in Figure 30.

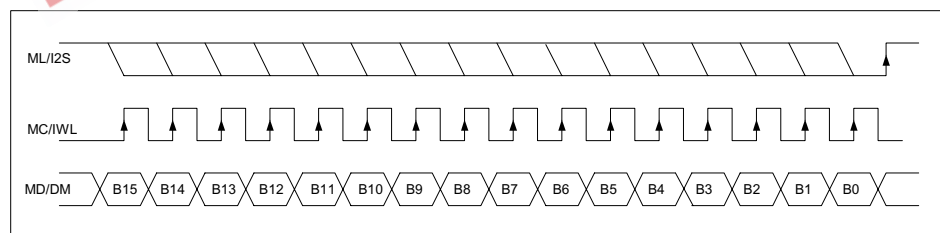

Figure 30 3-Wire SPI Compatible Interface

1. B[15:9] are Control Address Bits
2. B[8:0] are Control Data Bits
3. ML/I2S is edge sensitive – the data is latched on the rising edge of ML/I2S.

## REGISTER MAP - 28 PIN SSOP

The complete register map is shown below. The detailed description can be found in the relevant text of the device description. The WM8772EDS can be configured using the Control Interface. All unused bits should be set to '0'.

REGISTER	B15	B14	B13	B12	B11	B10	B9	B8	B7	B6	B5	B4	B3	B2	B1	B0	DEFAULT
R0(00h)	0	0	0	0	0	0	0	UPDATE	LDA1[7:0]								01111111
R1(01h)	0	0	0	0	0	0	1	UPDATE	RDA1[7:0]								01111111
R2(02h)	0	0	0	0	0	1	0	PL[8:5]			IZD	ATC	PDWN All DAC	DEEMP	MUTE All DAC	10010000	
R3(03h)	0	0	0	0	0	1	1	PHASE[8:6]			IWL[5:4]		BCP	LRP	FMT[1:0]		00000000
R4(04h)	0	0	0	0	1	0	0	UPDATE	LDA2[7:0]								01111111
R5(05h)	0	0	0	0	1	0	1	UPDATE	RDA2[7:0]								01111111
R6(06h)	0	0	0	0	1	1	0	UPDATE	LDA3[7:0]								01111111
R7(07h)	0	0	0	0	1	1	1	UPDATE	RDA3[7:0]								01111111
R8(08h)	0	0	0	1	0	0	0	UPDATE	MASTDA[7:0]								01111111
R9(09h)	0	0	0	1	0	0	1	DEEMP[8:6]			DMUTE[5:3]		DZFM[2:1]		ZCD	00000000	
R10(0Ah)	0	0	0	1	0	1	0	RATE[8:6]			MS	PWRDNL	DACPD[3:1]		ADCPD	01000000	
R11(0Bh)	0	0	0	1	0	1	1	ADC OSR	010			0	00		00		00100000
R12(0Ch)	0	0	0	1	1	0	0	0	0	MPD	0	0	ADCHP	AMUTE ALL	AMUTEL	AMUTER	00000000
R31(1Fh)	0	0	1	1	1	1	1	RESET								00000000	

## CONTROL INTERFACE REGISTERS

### ATTENUATOR CONTROL MODE

Setting the ATC register bit causes the left channel attenuation settings to be applied to both left and right channel DACs from the next audio input sample. No update to the attenuation registers is required for ATC to take effect.

REGISTER ADDRESS	BIT	LABEL	DEFAULT	DESCRIPTION
0000010 DAC Channel Control	3	ATC	0	Attenuator Control Mode: 0: Right channels use right attenuations 1: Right channels use left attenuations

### INFINITE ZERO DETECT ENABLE

Setting the IZD register bit will enable the internal infinite zero detect function:

REGISTER ADDRESS	BIT	LABEL	DEFAULT	DESCRIPTION
0000010 DAC Channel Control	4	IZD	0	Infinite Zero Mute Enable 0 : Disable infinite zero mute 1 : Enable infinite zero mute

With IZD enabled, applying 1024 consecutive zero input samples each stereo channel will cause that stereo channel outputs to be muted to  $V_{MID}$ . Mute will be removed as soon as that stereo channel receives a non-zero input.

### DAC OUTPUT CONTROL

The DAC output control word determines how the left and right inputs to the audio Interface are applied to the left and right DACs:

REGISTER ADDRESS	BIT	LABEL	DEFAULT	DESCRIPTION		
0000010 DAC Control	8:5	PL[3:0]	1001	PL[3:0]	Left Output	Right Output
				0000	Mute	Mute
				0001	Left	Mute
				0010	Right	Mute
				0011	(L+R)/2	Mute
				0100	Mute	Left
				0101	Left	Left
				0110	Right	Left
				0111	(L+R)/2	Left
				1000	Mute	Right
				1001	Left	Right
				1010	Right	Right
				1011	(L+R)/2	Right
				1100	Mute	(L+R)/2
				1101	Left	(L+R)/2
				1110	Right	(L+R)/2
1111	(L+R)/2	(L+R)/2				

**ADC AND DAC DIGITAL AUDIO INTERFACE CONTROL REGISTER**

Interface format is selected via the FMT[1:0] register bits:

REGISTER ADDRESS	BIT	LABEL	DEFAULT	DESCRIPTION
0000011 Interface Control	1:0	FMT [1:0]	00	Interface Format Select: 00 : Right justified mode 01: Left justified mode 10: I <sup>2</sup> S mode 11: DSP (early or late) mode

In left justified, right justified or I<sup>2</sup>S modes, the LRP register bit controls the polarity of LRC. If this bit is set high, the expected polarity of LRC will be the opposite of that shown Figure 23, Figure 24 and Figure 25. Note that if this feature is used as a means of swapping the left and right channels, a 1 sample phase difference will be introduced. In DSP modes, the LRP register bit is used to select between early and late modes.

REGISTER ADDRESS	BIT	LABEL	DEFAULT	DESCRIPTION
0000011 Interface Control	2	LRP	0	In left/right/I <sup>2</sup> S Modes: LRC Polarity (normal) 0 : Normal LRC polarity 1: Inverted LRC polarity In DSP Mode: 0 : Early DSP mode 1: Late DSP mode

By default, LRC and DIN1/2/3 are sampled on the rising edge of BCLK and should ideally change on the falling edge. By default, LRC and DOUT are sampled on the rising edge of BCLK and should ideally change on the falling edge. Data sources that change LRC and DOUT on the rising edge of BCLK can be supported by setting the BCP register bit. Data sources that change LRC and DIN1/2/3 on the rising edge of BCLK can be supported by setting the BCP register bit. Setting BCP to 1 inverts the polarity of BCLK to the inverse of that shown in Figure 23, Figure 24, Figure 25, Figure 26, Figure 27, Figure 28 and Figure 29.

REGISTER ADDRESS	BIT	LABEL	DEFAULT	DESCRIPTION
0000011 Interface Control	3	BCP	0	BCLK Polarity (DSP Modes): 0: Normal BCLK polarity 1: Inverted BCLK polarity

The IWL[1:0] bits are used to control the input word length.

REGISTER ADDRESS	BIT	LABEL	DEFAULT	DESCRIPTION
0000011 Interface Control	5:4	IWL [1:0]	00	Input Word Length: 00 : 16 bit data 01: 20 bit data 10: 24 bit data 11: 32 bit data

**Note:** 32-bit right justified mode is not supported.

In all modes, the data is signed 2's complement. The digital filters always input 24-bit data. If the DAC is programmed to receive 16 or 20 bit data, the WM8772EDS pads the unused LSBs with zeros. If the DAC is programmed into 32 bit mode, the 8 LSBs are ignored.

**Note:** In 24 bit I<sup>2</sup>S mode, any width of 24 bits or less is supported provided that LRC is high for a minimum of 24 BCLKs and low for a minimum of 24 BCLKs.

A number of options are available to control how data from the Digital Audio Interface is applied to the DAC channels.

**DAC OUTPUT PHASE**

The DAC Phase control word determines whether the output of each DAC is non-inverted or inverted

REGISTER ADDRESS	BIT	LABEL	DEFAULT	DESCRIPTION		
0000011 DAC Phase	8:6	PHASE [2:0]	000	Bit	DAC	Phase
				0	DAC1L/R	1 = invert
				1	DAC2L/R	1 = invert
				2	DAC3L/R	1 = invert

**DIGITAL ZERO CROSS-DETECT**

The Digital volume control also incorporates a zero cross detect circuit which detects a transition through the zero point before updating the digital volume control with the new volume. This is enabled by control bit DZCEN.

REGISTER ADDRESS	BIT	LABEL	DEFAULT	DESCRIPTION
0001001 DAC Control	0	ZCD	0	DAC Digital Volume Zero Cross Disable: 0: Zero cross detect enabled 1: Zero cross detect disabled

**MUTE FLAG OUTPUT**

The DZFM control bits allow the selection of the six DAC channel zero flag bits for output on the MUTE pin. A '1' on MUTE indicates 1024 consecutive zero input samples to the DAC channels selected.

REGISTER ADDRESS	BIT	LABEL	DEFAULT	DESCRIPTION
0001001 Zero Flag	2:1	DZFM[1:0]	00	Selects the output MUTE pin (A '1' indicates 1024 consecutive zero input samples on the DAC channels selected. 00: All channels zero 01: Channel 1 zero 10: Channel 2 zero 11: Channel 3 zero

**DAC MUTE MODES**

The WM8772EDS has individual mutes for each of the three DAC channels. Setting MUTE for a channel will apply a 'soft' mute to the input of the digital filters of the channel muted.

REGISTER ADDRESS	BIT	LABEL	DEFAULT	DESCRIPTION
0001001 DAC Mute	5:3	DMUTE [2:0]	000	DAC Soft Mute Select

DMUTE [2:0]	DAC CHANNEL 1	DAC CHANNEL 2	DAC CHANNEL 3
000	Not MUTE	Not MUTE	Not MUTE
001	MUTE	Not MUTE	Not MUTE
010	Not MUTE	MUTE	Not MUTE
011	MUTE	MUTE	Not MUTE
100	Not MUTE	Not MUTE	MUTE
101	MUTE	Not MUTE	MUTE
110	Not MUTE	MUTE	MUTE

Setting the MUTEALL register bit will apply a 'soft' mute to the input of all the DAC digital filters:

REGISTER ADDRESS	BIT	LABEL	DEFAULT	DESCRIPTION
0000010 DAC Mute	0	MUTEALL	0	Soft Mute Select: 0 : Normal operation 1: Soft mute all channels

Refer to Figure 19 for the plot of application and release of soft mute.

Note that all other means of muting the DAC channels: setting the PL[3:0] bits to 0, setting the PDWN bit or setting attenuation to 0 will cause much more abrupt muting of the output.

### ADC MUTE MODES

Each ADC channel also has a mute control bit, which mutes the inputs to the ADC.

REGISTER ADDRESS	BIT	LABEL	DEFAULT	DESCRIPTION
0001100 ADC Mute	0	AMUTER	0	ADC Mute Select: 0 : Normal operation 1: mute ADC right
	1	AMUTEL	0	ADC Mute Select: 0 : Normal operation 1: mute ADC left
	2	AMUTEALL	0	ADC Mute Select: 0 : Normal operation 1: mute both ADC channels

### DE-EMPHASIS MODE

Each stereo DAC channel has an individual de-emphasis control bit:

REGISTER ADDRESS	BIT	LABEL	DEFAULT	DESCRIPTION
0001001 DAC De-Emphasis Control	[8:6]	DEEMPH [1:0]	000	De-emphasis Channel Selection Select:

DEEMPH [1:0]	DAC CHANNEL 1	DAC CHANNEL 2	DAC CHANNEL 3
000	Not DE-EMPHASIS	Not DE-EMPHASIS	Not DE-EMPHASIS
001	DE-EMPHASIS	Not DE-EMPHASIS	Not DE-EMPHASIS
010	Not DE-EMPHASIS	DE-EMPHASIS	Not DE-EMPHASIS
011	DE-EMPHASIS	DE-EMPHASIS	Not DE-EMPHASIS
100	Not DE-EMPHASIS	Not DE-EMPHASIS	DE-EMPHASIS
101	DE-EMPHASIS	Not DE-EMPHASIS	DE-EMPHASIS
110	Not DE-EMPHASIS	DE-EMPHASIS	DE-EMPHASIS

Refer to Figure 7, Figure 8, Figure 9, Figure 10, Figure 11 and Figure 12 for details of the De-Emphasis performance at different sample rates.

REGISTER ADDRESS	BIT	LABEL	DEFAULT	DESCRIPTION
0000010 DAC DEMP	1	DEEMP ALL	0	DEMMP Select: 0 : Normal operation 1: De-emphasis all channels



**POWERDOWN MODE AND ADC/DAC DISABLE**

Setting the PDWN register bit immediately powers down the DAC's on the WM8772EDS, overriding the DACD powerdown bits control bits. All trace of the previous input samples are removed, but all control register settings are preserved. When PDWN is cleared the digital filters will be reinitialised

REGISTER ADDRESS	BIT	LABEL	DEFAULT	DESCRIPTION
0000010 Powerdown Control	2	PDWN	0	Power Down all DAC's Select: 0: All DAC's enabled 1: All DAC's disabled

The ADC and DACs may also be powered down individually by setting the ADCPD and DACPD disable bits. Setting ADCD will disable the ADC and select a low power mode. The ADC digital filters will be reset and will reinitialise when ADCPD is unset. Each Stereo DAC channel has a separate disable DACPD[2:0]. Setting DACPD for a channel will disable the DACs and select a low power mode.

REGISTER ADDRESS	BIT	LABEL	DEFAULT	DESCRIPTION
0001010 Powerdown Control	0	ADCPD	0	ADC Disable: 0: Active 1: Disable
	3:1	DACPD[2:0]	000	DAC Disable

DACPD [2:0]	DAC CHANNEL 1	DAC CHANNEL 2	DAC CHANNEL 3
000	Active	Active	Active
001	DISABLE	Active	Active
010	Active	DISABLE	Active
011	DISABLE	DISABLE	Active
100	Active	Active	DISABLE
101	DISABLE	Active	DISABLE
110	Active	DISABLE	DISABLE
111	DISABLE	DISABLE	DISABLE

**MASTER POWERDOWN**

This control bit powers down the references for the whole chop. Therefore for complete powerdown, both the ADC and DACs should be powered down first before setting this bit.

REGISTER ADDRESS	BIT	LABEL	DEFAULT	DESCRIPTION
0001010 Interface Control	4	PWRDNALL	0	Master Power Down Bit: 0: Not powered down 1: Powered down

**MASTER MODE SELECT**

Control bit MS selects between audio interface Master and Slave Modes. In Master mode LRC and BCLK are outputs and are generated by the WM8772EDS. In Slave mode LRC and BCLK are inputs to WM8772EDS.

REGISTER ADDRESS	BIT	LABEL	DEFAULT	DESCRIPTION
0001010 Interface Control	5	MS	0	DAC Audio Interface Master/Slave Mode Select: 0: Slave mode 1: Master mode

**MASTER MODE LRC FREQUENCY SELECT**

In Master mode the WM8772EDS generates LRC and BCLK. These clocks are derived from the master clock and the ratio of MCLK to LRC is set by RATE.

REGISTER ADDRESS	BIT	LABEL	DEFAULT	DESCRIPTION
0001010 Interface Control	8:6	RATE [2:0]	010	Master Mode MCLK:LRC Ratio Select: 000: 128fs (DAC only) 001: 192fs (DAC only) 010: 256fs 011: 384fs 100: 512fs 101: 768fs

**ADC OVERSAMPLING RATE SELECT**

For ADC operation at 96kHz it is recommended that the user set the ADCOSR bit. This changes the ADC signal processing oversample rate to 64fs. The 64fs oversampling rate is only available in modes where a 96kHz rate is supported, i.e. 256fs or 384fs. In all other modes the ADC will stay in a 128fs oversampling rate irrespective of what this bit is set to.

REGISTER ADDRESS	BIT	LABEL	DEFAULT	DESCRIPTION
0001011 ADC Oversampling Rate	8	ADCOSR	0	ADC Oversampling Rate Select: 0: 128x oversampling 1: 64x oversampling

**ADC HIGHPASS FILTER DISABLE**

The ADC digital filters contain a digital highpass filter. This defaults to enabled and can be disabled using software control bit ADCHPD.

REGISTER ADDRESS	BIT	LABEL	DEFAULT	DESCRIPTION
0001100 ADC Control	3	ADCHPD	0	ADC Highpass Filter Disable: 0: Highpass filter enabled 1: Highpass filter disabled

**MUTE PIN DECODE**

The MUTE pin can either be used as an output or an input. When used as an input the MUTE pins action can be controlled by setting the DZFM bit to select the corresponding DAC for applying the MUTE to. As an output its meaning is selected by the DZFM control bits. By default selecting the MUTE to represent if DAC1 has received more than 1024 midrail samples will cause the MUTE to be asserted a softmute on DAC1. Disabling the decode block will cause any logical high on the MUTE pin to apply a softmute to all DAC's.

REGISTER ADDRESS	BIT	LABEL	DEFAULT	DESCRIPTION
0001100 ADC Control	6	MPD	0	MUTE Pin Decode Disable: 0: MUTE pin decode enable 1: MUTE pin decode disable

**DAC DIGITAL VOLUME CONTROL**

The DAC volume may also be adjusted in the digital domain using independent digital attenuation control registers

REGISTER ADDRESS	BIT	LABEL	DEFAULT	DESCRIPTION
0000000 Digital Attenuation DACL1	7:0	LDA1[7:0]	11111111 (0dB)	Digital Attenuation data for Left channel DACL1 in 0.5dB steps. See Table 11
	8	UPDATE	Not latched	Controls simultaneous update of all Attenuation Latches 0: Store LDA1 in intermediate latch (no change to output) 1: Store LDA1 and update attenuation on all channels
0000001 Digital Attenuation DACR1	7:0	RDA1[6:0]	11111111 (0dB)	Digital Attenuation data for Right channel DACR1 in 0.5dB steps. See Table 11
	8	UPDATE	Not latched	Controls simultaneous update of all Attenuation Latches 0: Store RDA1 in intermediate latch (no change to output) 1: Store RDA1 and update attenuation on all channels.
0000100 Digital Attenuation DACL2	7:0	LDA2[7:0]	11111111 (0dB)	Digital Attenuation data for Left channel DACL2 in 0.5dB steps. See Table 11
	8	UPDATE	Not latched	Controls simultaneous update of all Attenuation Latches 0: Store LDA2 in intermediate latch (no change to output) 1: Store LDA2 and update attenuation on all channels.
0000101 Digital Attenuation DACR2	7:0	RDA2[7:0]	11111111 (0dB)	Digital Attenuation data for Right channel DACR2 in 0.5dB steps. See Table 11
	8	UPDATE	Not latched	Controls simultaneous update of all Attenuation Latches 0: Store RDA2 in intermediate latch (no change to output) 1: Store RDA2 and update attenuation on all channels.
0000110 Digital Attenuation DACL3	7:0	LDA3[7:0]	11111111 (0dB)	Digital Attenuation data for Left channel DACL3 in 0.5dB steps. See Table 11
	8	UPDATE	Not latched	Controls simultaneous update of all Attenuation Latches 0: Store LDA3 in intermediate latch (no change to output) 1: Store LDA3 and update attenuation on all channels.
0000111 Digital Attenuation DACR3	7:0	RDA3[7:0]	11111111 (0dB)	Digital Attenuation data for Right channel DACR3 in 0.5dB steps. See Table 11
	8	UPDATE	Not latched	Controls simultaneous update of all Attenuation Latches 0: Store RDA3 in intermediate latch (no change to output) 1: Store RDA3 and update attenuation on all channels.
0001000 Master Digital Attenuation (all channels)	7:0	MASTDA [7:0]	11111111 (0dB)	Digital Attenuation data for all DAC channels in 0.5dB steps. See Table 11
	8	UPDATE	Not latched	Controls simultaneous update of all Attenuation Latches 0: Store gain in intermediate latch (no change to output) 1: Store gain and update attenuation on all channels.

L/RDAX[7:0]	ATTENUATION LEVEL
00(hex)	-∞ dB (mute)
01(hex)	-127dB
:	:
:	:
:	:
FE(hex)	-0.5dB
FF(hex)	0dB

**Table 11 Digital Volume Control Attenuation Levels**

**SOFTWARE REGISTER RESET**

Writing to register 11111 will cause a register reset, resetting all register bits to their default values. The device will be held in this reset state until a subsequent register write to any address is completed.

EEPW 电子產品世界  
.com.cn

## APPLICATIONS INFORMATION

## RECOMMENDED EXTERNAL COMPONENTS

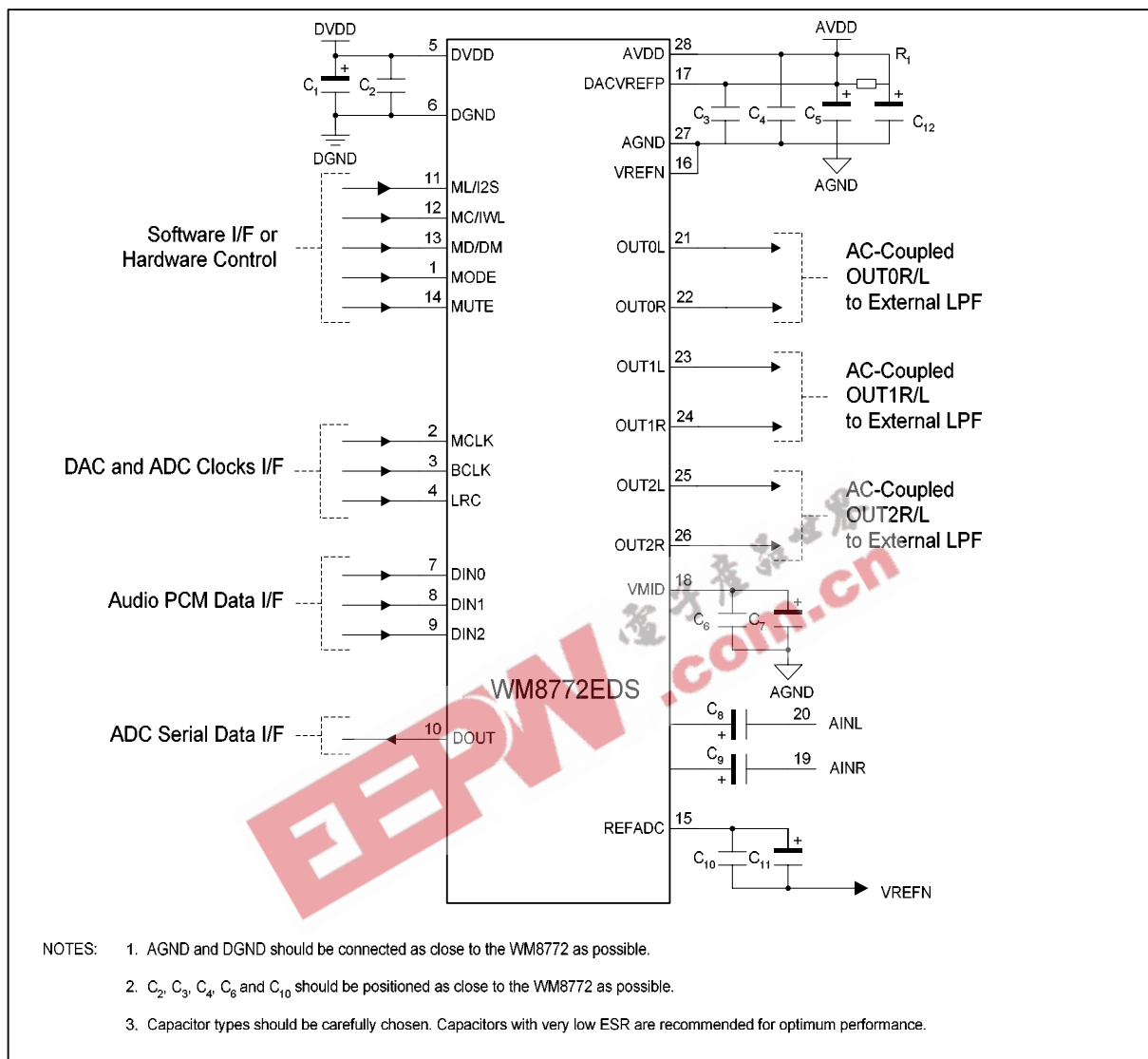

## RECOMMENDED EXTERNAL COMPONENTS VALUES

COMPONENT REFERENCE	SUGGESTED VALUE	DESCRIPTION
C1 and C5	10 $\mu$ F	De-coupling for DVDD and AVDD.
C2 to C4	0.1 $\mu$ F	De-coupling for DVDD and AVDD.
C8 and C9	1 $\mu$ F	Analogue input high pass filter capacitors
C6 and C10	0.1 $\mu$ F	Reference de-coupling capacitors for VMID and ADCREF pin.
C7 and C11	10 $\mu$ F	
C12	10 $\mu$ F	Filtering for VREFP. Omit if AVDD low noise.
R1	330 $\Omega$	Filtering for VREFP. Use 0 $\Omega$ if AVDD low noise.

Table 12 External Components Description

**SUGGESTED ANALOGUE LOW PASS POST DAC FILTERS**

It is recommended that a lowpass filter be applied to the output from each DAC channel for Hi Fi applications. Typically a second order filter is suitable and provides sufficient attenuation of high frequency components (the unique low order, high bit count multi-bit sigma delta DAC structure used in WM8772EDS produces much less high frequency output noise than normal sigma delta DACs. This filter is typically also used to provide the 2x gain needed to provide the standard 2Vrms output level from most consumer equipment.

Figure 31 shows a suitable post DAC filter circuit, with 2x gain. Alternative inverting filter architectures might also be used with as good results.

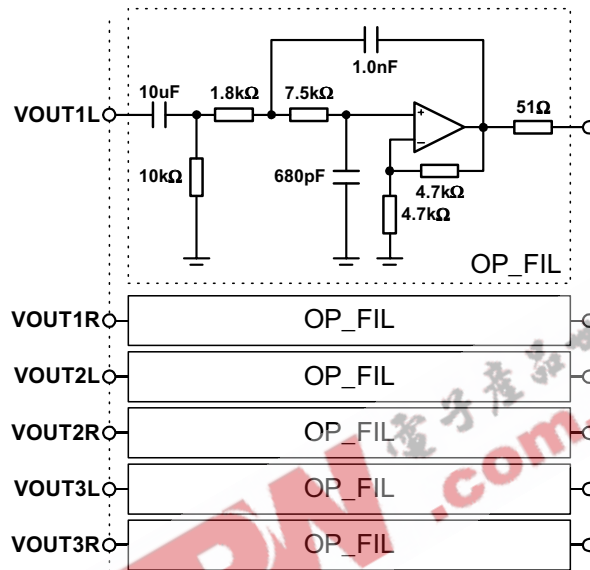
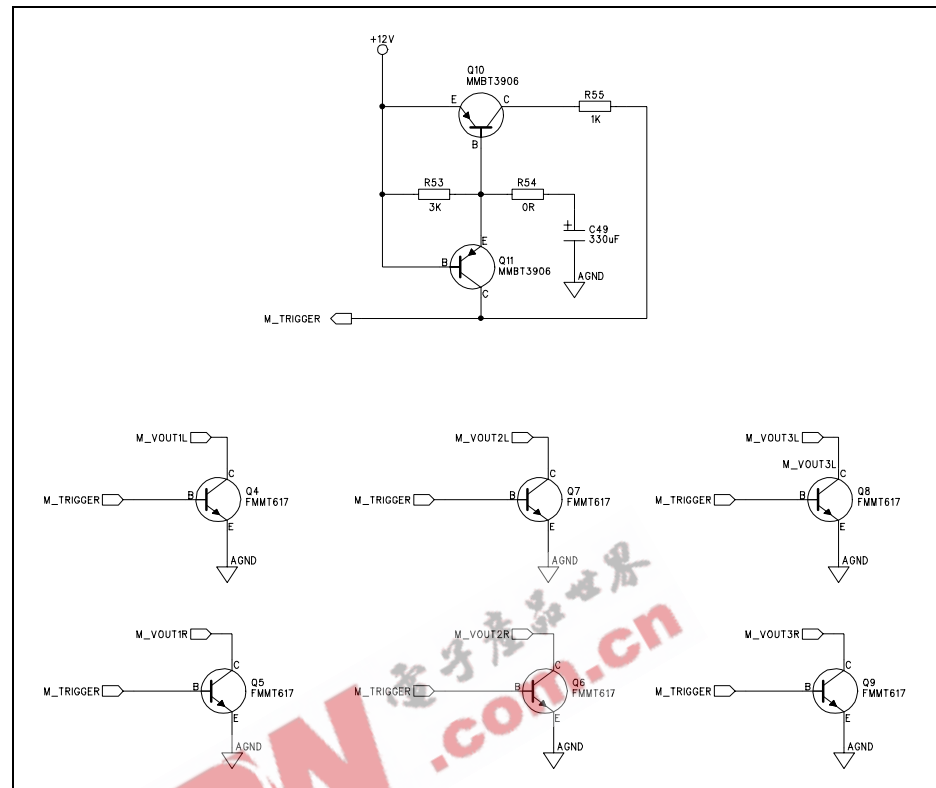

Figure 31 Recommended Post DAC Filter Circuit

To ensure that system 'pop' noise is kept to a minimum when power is applied or removed, a transistor clamp circuit arrangement may be added to the output connectors of the system. A recommended clamp circuit configuration is shown below.



**Figure 32 Output Clamp Circuit**

When the +VS power supply is applied, PNP transistor Q10 of the trigger circuit is held on until capacitor C49 is fully charged. With transistor Q10 held 'on', NPN transistors Q4 to Q9 of the clamp circuits are also switched on holding the system outputs near to GND. When capacitor C49 is fully charged transistors Q10 and Q4 to Q9 are switched off setting the outputs active.

When the +VS power supply is removed, PNP transistor Q11 of the trigger circuit is switched on. In turn, transistors Q4 to Q9 of the clamp circuits are switched on holding the outputs of the evaluation board near to GND until the rest of the circuitry on the board has settled.

**Note:** It is recommended that low  $V_{ce_{sat}}$  switching transistors should be used in this circuit to ensure that the clamp is applied before the rest of the circuitry has time to power down.

**Important:** If a trigger circuit such as the one shown is to be used, it is important that the +VS supply drops quicker than any other supply to ensure that the outputs are clamped during the period when 'pop' noise may occur.

PACKAGE DIMENSIONS

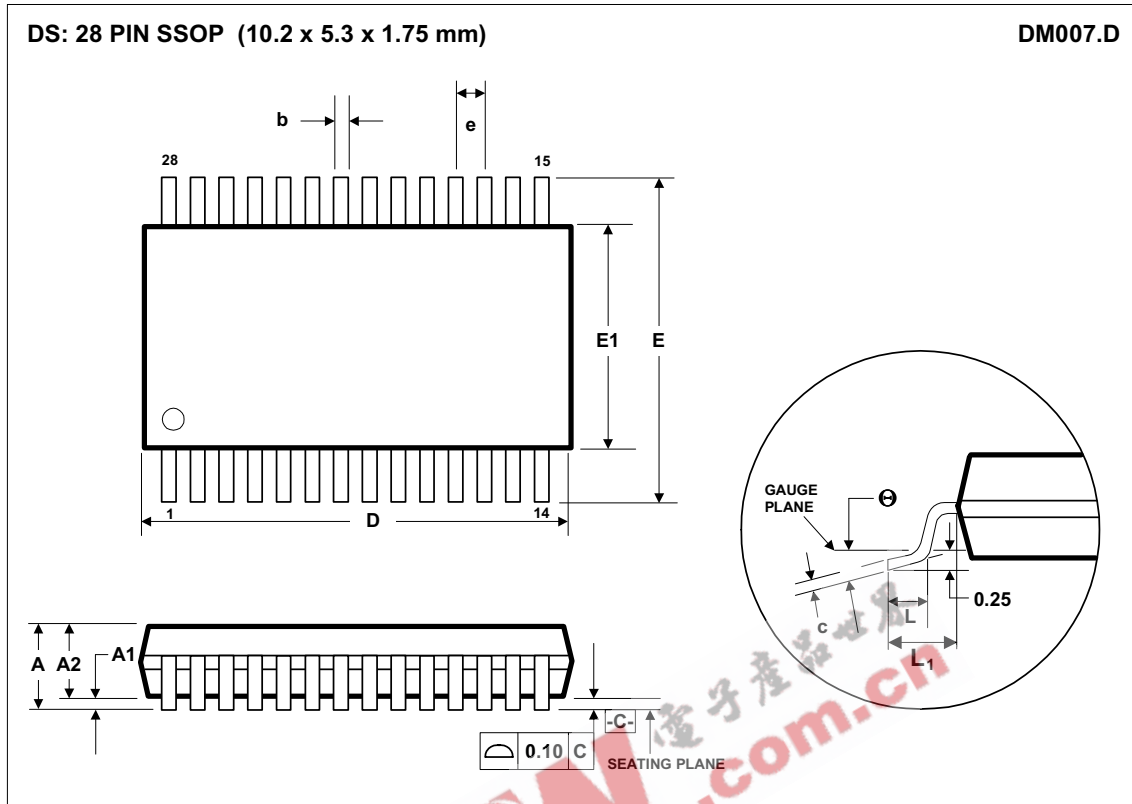

Symbols	Dimensions (mm)		
	MIN	NOM	MAX
A	-----	-----	2.0
A <sub>1</sub>	0.05	-----	0.25
A <sub>2</sub>	1.65	1.75	1.85
b	0.22	0.30	0.38
c	0.09	-----	0.25
D	9.90	10.20	10.50
e	0.65 BSC		
E	7.40	7.80	8.20
E <sub>1</sub>	5.00	5.30	5.60
L	0.55	0.75	0.95
L <sub>1</sub>	0.125 REF		
θ	0°	4°	8°
REF:	JEDEC.95, MO-150		

- NOTES:  
 A. ALL LINEAR DIMENSIONS ARE IN MILLIMETERS.  
 B. THIS DRAWING IS SUBJECT TO CHANGE WITHOUT NOTICE.  
 C. BODY DIMENSIONS DO NOT INCLUDE MOLD FLASH OR PROTRUSION, NOT TO EXCEED 0.20MM.  
 D. MEETS JEDEC.95 MO-150, VARIATION = AH. REFER TO THIS SPECIFICATION FOR FURTHER DETAILS.



WM8722EFT - 32 PIN TQFP

MASTER CLOCK TIMING

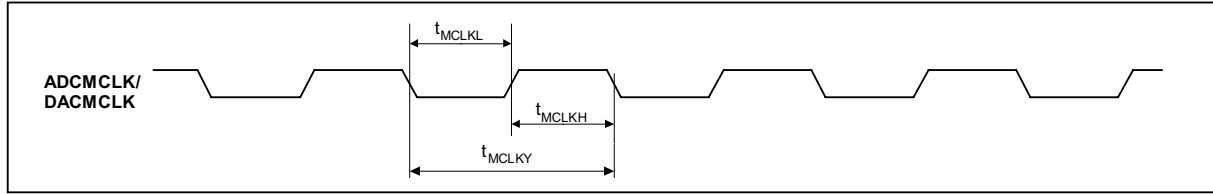

Figure 33 ADC and DAC Master Clock Timing Requirements

Test Conditions

AVDD, VREFP = 5V, DVDD = 3.3V, AGND, VREFN = 0V, AGND, DGND = 0V,  $T_A = +25^\circ\text{C}$ , fs = 48kHz, DACMCLK and ADCMCLK = 256fs unless otherwise stated.

PARAMETER	SYMBOL	TEST CONDITIONS	MIN	TYP	MAX	UNIT
<b>System Clock Timing Information</b>						
ADCMCLK and DACMCLK System clock pulse width high	$t_{MCLKH}$		11			ns
ADCMCLK and DACMCLK System clock pulse width low	$t_{MCLKL}$		11			ns
ADCMCLK and DACMCLK System clock cycle time	$t_{MCLKY}$		28			ns
ADCMCLK and DACMCLK Duty cycle			40:60		60:40	

Table 13 Master Clock Timing Requirements

DIGITAL AUDIO INTERFACE – MASTER MODE

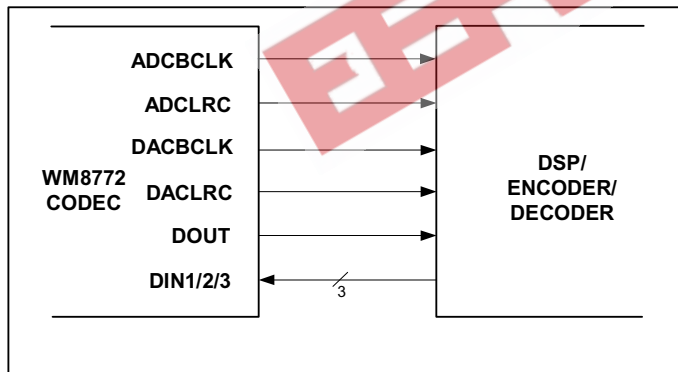

Figure 34 Audio Interface - Master Mode

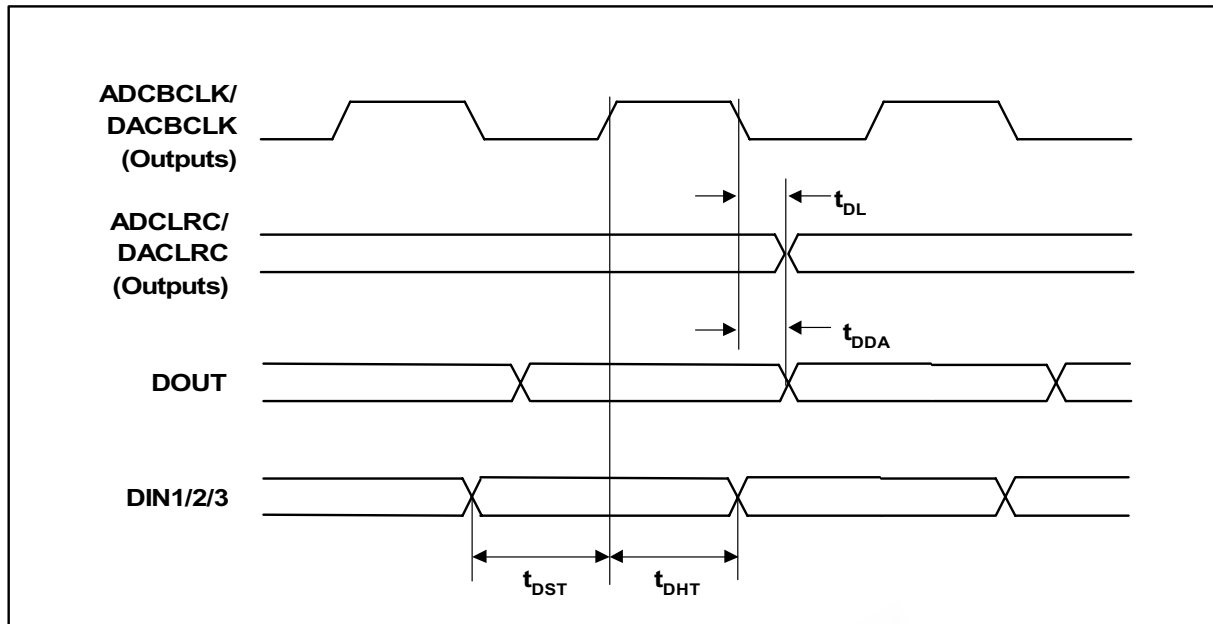

Figure 35 Digital Audio Data Timing – Master Mode

**Test Conditions**

AVDD, VREFP = 5V, DVDD = 3.3V, AGND, VREFN, DGND = 0V, T<sub>A</sub> = +25°C, Master Mode, f<sub>s</sub> = 48kHz, DACMCLK and ADCMCLK = 256fs unless otherwise stated.

PARAMETER	SYMBOL	TEST CONDITIONS	MIN	TYP	MAX	UNIT
<b>Audio Data Input Timing Information</b>						
ADCLRC/DACLRC propagation delay from ADCBCLK/DACBCLK falling edge	t <sub>DL</sub>		0		10	ns
DOUT propagation delay from ADCBCLK falling edge	t <sub>DDA</sub>		0		10	ns
DIN1/2/3 setup time to DACBCLK rising edge	t <sub>DST</sub>		10			ns
DIN1/2/3 hold time from DACBCLK rising edge	t <sub>DHT</sub>		10			ns

Table 14 Digital Audio Data Timing – Master Mode

DIGITAL AUDIO INTERFACE – SLAVE MODE

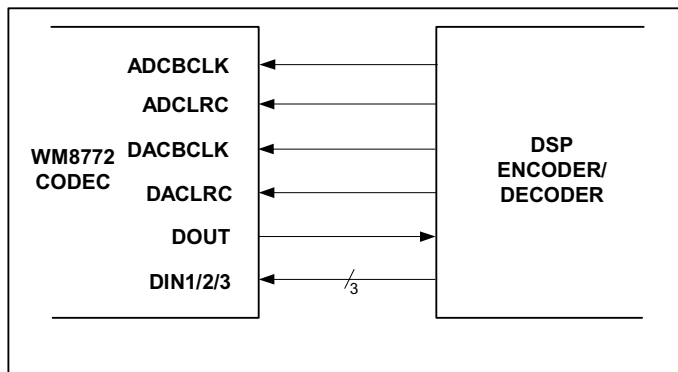

Figure 36 Audio Interface – Slave Mode

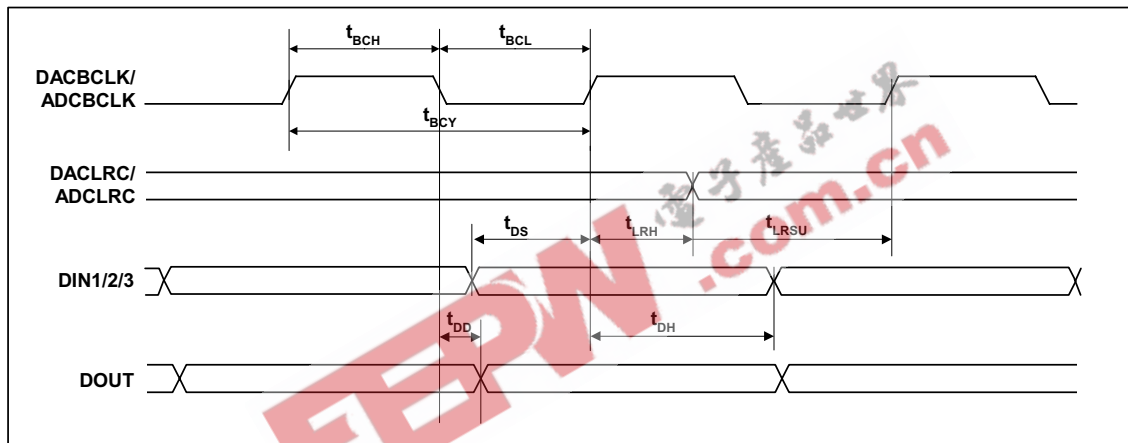

Figure 37 Digital Audio Data Timing – Slave Mode

**Test Conditions**

AVDD = 5V, DVDD = 3.3V, AGND = 0V, DGND = 0V, T<sub>A</sub> = +25°C, Slave Mode, fs = 48kHz, DACMCLK and ADCMCLK = 256fs unless otherwise stated.

PARAMETER	SYMBOL	TEST CONDITIONS	MIN	TYP	MAX	UNIT
<b>Audio Data Input Timing Information</b>						
ADCBCLK/DACBCLK cycle time	t <sub>BCY</sub>		50			ns
ADCBCLK/DACBCLK pulse width high	t <sub>BCH</sub>		20			ns
ADCBCLK/DACBCLK pulse width low	t <sub>BCL</sub>		20			ns
ADCLRC/DACLRC set-up time to ADCBCLK/DACBCLK rising edge	t <sub>LRSU</sub>		10			ns
ADCLRC/DACLRC hold time from ADCBCLK/DACBCLK rising edge	t <sub>LRH</sub>		10			ns
DIN1/2/3 set-up time to DACBCLK rising edge	t <sub>DS</sub>		10			ns
DIN1/2/3 hold time from DACBCLK rising edge	t <sub>DH</sub>		10			ns
DOUT propagation delay from ADCBCLK falling edge	t <sub>DD</sub>		0		10	ns

Table 15 Digital Audio Data Timing – Slave Mode

**MPU INTERFACE TIMING**

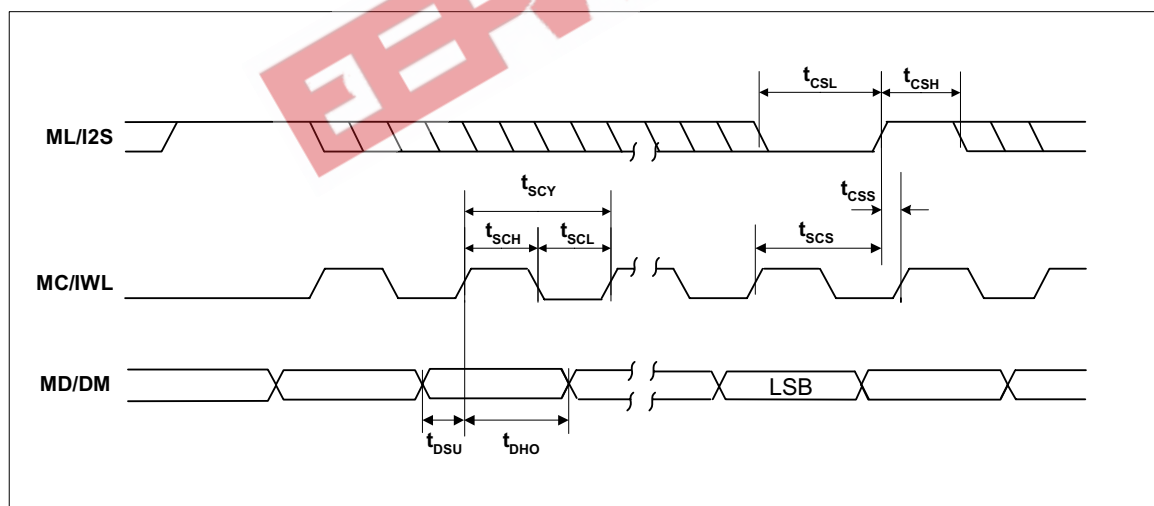

Figure 38 SPI Compatible Control Interface Input Timing

**Test Conditions**

AVDD = 5V, DVDD = 3.3V, AGND, DGND = 0V,  $T_A = +25^\circ\text{C}$ ,  $f_s = 48\text{kHz}$ , DACMCLK and ADCMCLK = 256fs unless otherwise stated

PARAMETER	SYMBOL	MIN	TYP	MAX	UNIT
MC/IWL rising edge to ML/I2S rising edge	$t_{SCS}$	60			ns
MC/IWL pulse cycle time	$t_{SCY}$	80			ns
MC/IWL pulse width low	$t_{SCL}$	30			ns
MC/IWL pulse width high	$t_{SCH}$	30			ns
MD/DM to MC/IWL set-up time	$t_{DSU}$	20			ns
MC/IWL to MD/DM hold time	$t_{DHO}$	20			ns
ML/I2S pulse width low	$t_{CSL}$	20			ns
ML/I2S pulse width high	$t_{CSH}$	20			ns
ML/I2S rising to MC/IWL rising	$t_{CSS}$	20			ns

**Table 16 3-Wire SPI Compatible Control Interface Input Timing Information**

EEPW 电子产品世界 .com.cn

## DEVICE DESCRIPTION

### INTRODUCTION

WM8772EFT is a complete 6-channel DAC, 2-channel ADC audio codec, including digital interpolation and decimation filters, multi-bit sigma delta stereo ADC, and switched capacitor multi-bit sigma delta DACs with digital volume controls on each channel and output smoothing filters.

The device is implemented as three separate stereo DACs and a stereo ADC in a single package and controlled by a single interface.

Each stereo DAC has its own data input DIN1/2/3. DAC word clock DACLRC, DAC bit clock DACBCLK and DAC master clock DACMCLK are shared between them. The stereo ADC has its own data output DOUT, word clock ADCLRC, bit clock ADCBCLK and ADC master clock ADCMCLK. This allows the ADC and DAC to run independently.

The Audio Interface may be configured to operate in either master or slave mode. In Slave mode ADCLRC and ADCBCLK, DACLRC and DACBCLK are all inputs. In Master mode ADCLRC and ADCBCLK, DACLRC and DACBCLK are all outputs. The DAC's and ADC can be in any combination of master or slave mode.

Each DAC has its own digital volume control that is adjustable in 0.5dB steps. The digital volume controls may be operated independently. In addition, a zero cross detect circuit is provided for each DAC for the digital volume controls. The digital volume control detects a transition through the zero point before updating the volume. This minimises audible clicks and 'zipper' noise as the gain values change.

Control of internal functionality of the device is by 3-wire serial or pin programmable control interface. The software control interface may be asynchronous to the audio data interface as control data will be re-synchronised to the audio processing internally.

Operation using master clocks of 128fs, 192fs, 256fs, 384fs, 512fs or 768fs is provided for the DAC, and 256fs, 384fs, 512fs, and 768fs is provided for the ADC. In Slave mode selection between clock rates is automatically controlled. In master mode, the sample rate is set by control bits ADCRATE and DACRATE. Audio sample rates (fs) from less than 8ks/s up to 192ks/s are allowed for the DAC and from less than 32ks/s up to 96ks/s for the ADC, provided the appropriate master clock is input.

The audio data interface supports right, left and I<sup>2</sup>S interface formats along with a highly flexible DSP serial port interface.

### AUDIO DATA SAMPLING RATES

In a typical digital audio system there is only one central clock source producing a reference clock to which all audio data processing is synchronised. This clock is often referred to as the audio system's Master Clock. The external master system clock can be applied directly through the ADC and DAC MCLK input pin(s) with no software configuration necessary. In a system where there are a number of possible sources for the reference clock it is recommended that the clock source with the lowest jitter be used to optimise the performance of the ADC and DAC.

The DAC master clock for WM8772EFT supports audio sampling rates from 128fs to 768fs, where fs is the audio sampling frequency (DACLRC) typically 32kHz, 44.1kHz, 48kHz, 96kHz or 192kHz (for DAC operation only). The ADC master clock for WM8772EFT supports audio sampling rates from 256fs to 768fs, where fs is the audio sampling frequency (ADCLRC) typically 32kHz, 44.1kHz, 48kHz, 96kHz or 192kHz. The master clock is used to operate the digital filters and the noise shaping circuits.

In Slave mode the WM8772EFT has a master clock detection circuit that automatically determines the relationship between the system clock frequency and the sampling rate (to within +/- 32 master clocks). If there is a greater than 32 clocks error the interface defaults to 768fs mode. The master clocks must be synchronised with ADCLRC and DACLRC respectively, although the WM8772EFT is tolerant of phase variations or jitter on this clock. Table 6 shows the typical master clock frequency inputs for the WM8772EFT.

The signal processing for the WM8772EFT typically operates at an oversampling rate of 128fs for both ADC and DAC. The exception to this for the DAC is for operation with a 128/192fs system clock, e.g. for 192kHz operation, when the oversampling rate is 64fs. For ADC operation at 96kHz it is recommended that the user set the ADCOSR bit. This changes the ADC signal processing oversample rate to 64fs.

SAMPLING RATE (DACLRC/ ADCLRC)	System Clock Frequency (MHz)					
	128fs	192fs	256fs	384fs	512fs	768fs
32kHz	4.096	6.144	8.192	12.288	16.384	24.576
44.1kHz	5.6448	8.467	11.2896	16.9340	22.5792	33.8688
48kHz	6.144	9.216	12.288	18.432	24.576	36.864
96kHz	12.288	18.432	24.576	36.864	Unavailable	Unavailable
192kHz	24.576	36.864	Unavailable	Unavailable	Unavailable	Unavailable

**Table 17 System Clock Frequencies Versus Sampling Rate**  
(ADC does not support 128fs and 192fs)

## HARDWARE CONTROL MODES

When the MODE pin is held high, the following hardware modes of operation are available.

**Note:** When in hardware mode the ADC and DAC will only run in slave mode.

### MUTE AND AUTOMUTE OPERATION

In both hardware and software modes, MUTE controls the selection of MUTE directly, and can be used to enable and disable the automute function. This pin becomes an output when left floating and indicates infinite ZERO detect (IZD) has been detected.

	DESCRIPTION
0	Normal Operation
1	Mute DAC channels
Floating	Enable IZD, MUTE becomes an output to indicate when IZD occurs. L=IZD detected, H=IZD not detected.

**Table 18 Mute and Automute Control**

Figure 39 shows the application and release of MUTE whilst a full amplitude sinusoid is being played at 48kHz sampling rate. When MUTE (lower trace) is asserted, the output (upper trace) begins to decay exponentially from the DC level of the last input sample. The output will decay towards  $V_{MID}$  with a time constant of approximately 64 input samples. If MUTE is applied to all channels for 1024 or more input samples the outputs will be connected directly to  $V_{MID}$  if IZD is set. When MUTE is de-asserted, the output will restart immediately from the current input sample.

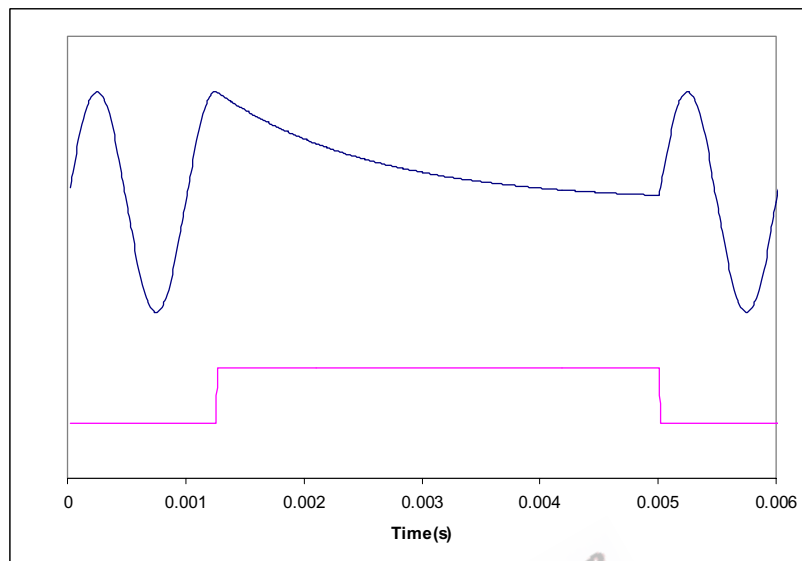

Figure 39 Application and Release of Soft Mute

The MUTE pin is an input to select mute or not mute. MUTE is active high; taking the pin high causes the filters to soft mute, ramping down the audio signal over a few milliseconds. Taking MUTE low again allows data into the filter.

The automute function detects a series of ZERO value audio samples of 1024 samples long being applied to both channels. After such an event, a latch is set whose output (AUTOMUTED) is wire OR'ed through a 10kΩ resistor to the MUTE pin. Thus if the MUTE pin is not being driven, the automute function will assert mute.

If MUTE is tied low, AUTOMUTED is overridden and will not mute unless the IZD register bit is set. If MUTE is driven from a bi-directional source, then both MUTE and automute functions are available. If MUTE is not driven, AUTOMUTED appears as a weak output (10kΩ source impedance) and can be used to drive external mute circuits. AUTOMUTED will be removed as soon as any channel receives a non-ZERO input.

A diagram showing how the various Mute modes interact is shown below Figure 20.

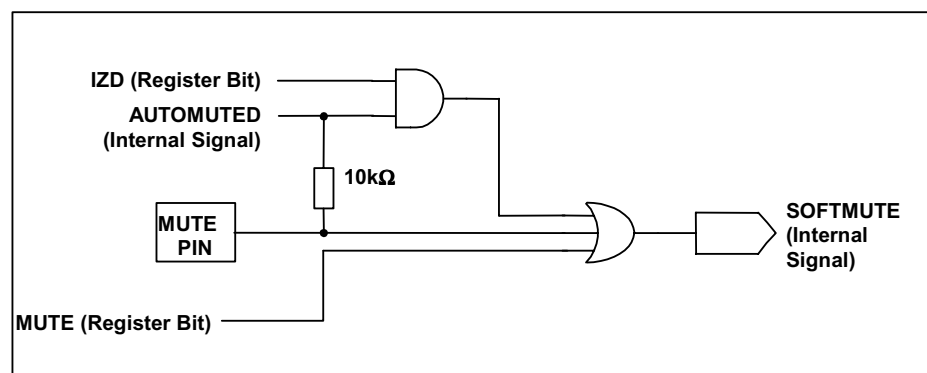

Figure 40 Selection Logic for MUTE Modes



### INPUT FORMAT SELECTION

In hardware mode, ML/I2S and MC/IWL become input controls for selection of input data format type and input data word length for both the ADC and DAC.

ML/I2S	MC/IWL	INPUT DATA MODE
0	0	24-bit right justified
0	1	20-bit right justified
1	0	16-bit I <sup>2</sup> S
1	1	24-bit I <sup>2</sup> S

Table 19 Input Format Selection

#### Note:

In 24 bit I<sup>2</sup>S mode, any width of 24 bits or less is supported provided that the left/right clocks (ADCLRC and DACLRC) are high for a minimum of 24 bit clocks (ADCBCLK and DACBCLK) and low for a minimum of 24 bit clocks.

### DE-EMPHASIS CONTROL

In hardware mode, the MD/DM pin becomes an input control for selection of de-emphasis filtering to be applied.

MD/DM	DE-EMPHASIS
0	Off
1	On

Table 20 De-emphasis Control

## DIGITAL AUDIO INTERFACE

### MASTER AND SLAVE MODES

The audio interface operates in either Slave or Master mode, selectable using the DACMS and ADCMS control bits. In both Master and Slave modes DIN1/2/3 are always inputs to the WM8772EFT and DOUT is always an output. The default is Slave mode for ADC and DAC.

In Slave mode, ADCLRC, DACLRC and ADCBCLK, DACBCLK are inputs to the WM8772EFT (Figure 21). DIN1/2/3, ADCLRC and DACLRC are sampled by the WM8772EFT on the rising edge of ADCBCLK and DACBCLK respectively. ADC data is output on DOUT and changes on the falling edge of ADCBCLK.

By setting the control bit DACBCP the polarity of DACBCLK may be reversed so that DIN1/2/3 and DACLRC are sampled on the falling edge of DACBCLK.

By setting the control bit ADCBCP the polarity of ADCBCLK may be reversed so that ADCLRC is sampled on the falling edge of ADCBCLK and DOUT changes on the rising edge of ADCBCLK.

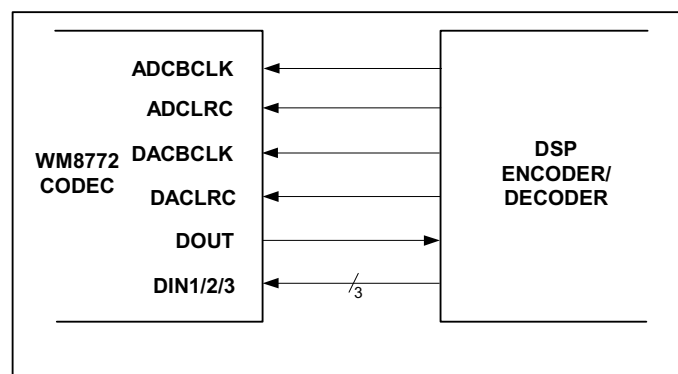

Figure 41 Slave Mode

In Master mode, ADCLRC, DACLRC, ADCBCLK and DACBCLK are outputs from the WM8772EFT (Figure 22). ADCLRC, DACLRC, ADCBCLK and DACBCLK are generated by the WM8772EFT.

DIN1/2/3 are sampled by the WM8772EFT on the rising edge of DACBCLK so the controller must output DAC data that changes on the falling edge of DACBCLK. ADC data is output on DOUT and changes on the falling edge of ADCBCLK.

By setting control bit DACBCP the polarity of DACBCLK may be reversed so that DIN1/2/3 are sampled on the falling edge of DACBCLK.

By setting control bit ADCBCP the polarity of ADCBCLK may be reversed so that DOUT changes on the rising edge of ADCBCLK.

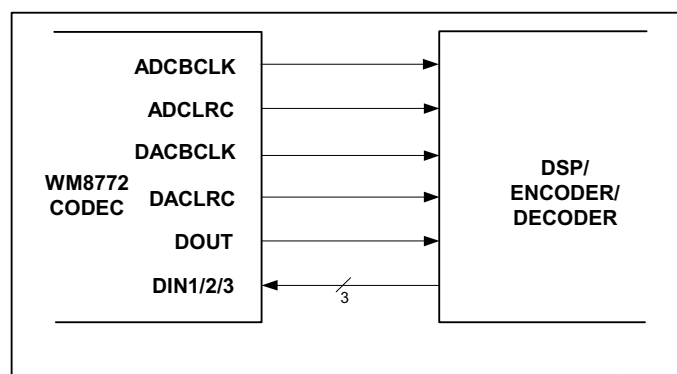

Figure 42 Master Mode

### AUDIO INTERFACE FORMATS

Audio data is applied to the internal DAC filters, or output from the ADC filters, via the Digital Audio Interface. 5 popular interface formats are supported:

- Left Justified mode
- Right Justified mode
- I<sup>2</sup>S mode
- DSP Early mode
- DSP Late mode

All 5 formats send the MSB first and support word lengths of 16, 20, 24 and 32 bits, with the exception of 32 bit right justified mode, which is not supported.

In left justified, right justified and I<sup>2</sup>S modes, the digital audio interface receives DAC data on the DIN1/2/3 inputs and outputs ADC data on DOUT. Audio Data for each stereo channel is time multiplexed with ADCLRC or DACLRC indicating whether the left or right channel is present. ADCLRC or DACLRC is also used as a timing reference to indicate the beginning or end of the data words.

In left justified, right justified and I<sup>2</sup>S modes, the minimum number of DACBCLK/ADCBCLK's per DACLRC/ADCLRC period is 2 times the selected word length. ADCLRC/DACLRC must be high for a minimum of word length DACBCLK/ADCBCLK's and low for a minimum of word length DACBCLK/ADCBCLK's. Any mark to space ratio on ADCLRC/DACLRC is acceptable provided the above requirements are met.

In DSP early or DSP late mode, all 6 DAC channels are time multiplexed onto DIN1. DACLRC is used as a frame sync signal to identify the MSB of the first word. The minimum number of DACBCLK's per DACLRC period is 6 times the selected word length. Any mark to space ratio is acceptable on DACLRC provided the rising edge is correctly positioned. The ADC data may also be output in DSP early or late modes, with ADCLRC used as a frame sync to identify the MSB of the first word. The minimum number of ADCBCLK's per ADCLRC period is 2 times the selected word length.

**LEFT JUSTIFIED MODE**

In left justified mode, the MSB of DIN1/2/3 is sampled by the WM8772EFT on the first rising edge of DACBCLK following a DACLRC transition. The MSB of the ADC data is output on DOUT and changes on the same falling edge of ADCBCLK as ADCLRC and may be sampled on the rising edge of ADCBCLK. ADCLRC and DACLRC are high during the left samples and low during the right samples (Figure 43).

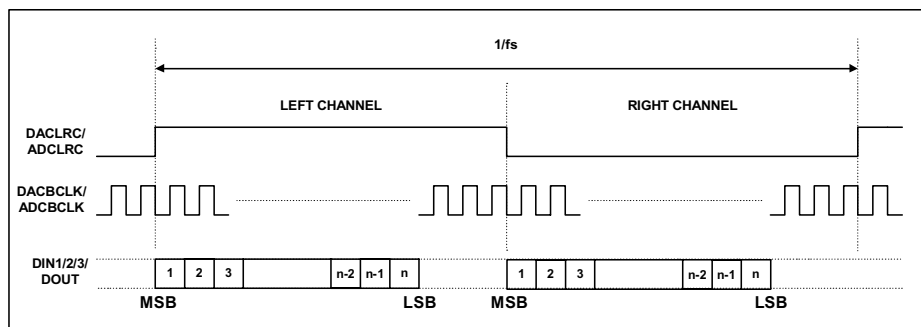

**Figure 43 Left Justified Mode Timing Diagram**

**RIGHT JUSTIFIED MODE**

In right justified mode, the LSB of DIN1/2/3 is sampled by the WM8772EFT on the rising edge of DACBCLK preceding a DACLRC transition. The LSB of the ADC data is output on DOUT and changes on the falling edge of ADCBCLK preceding a ADCLRC transition and may be sampled on the rising edge of ADCBCLK. ADCLRC and DACLRC are high during the left samples and low during the right samples (Figure 44).

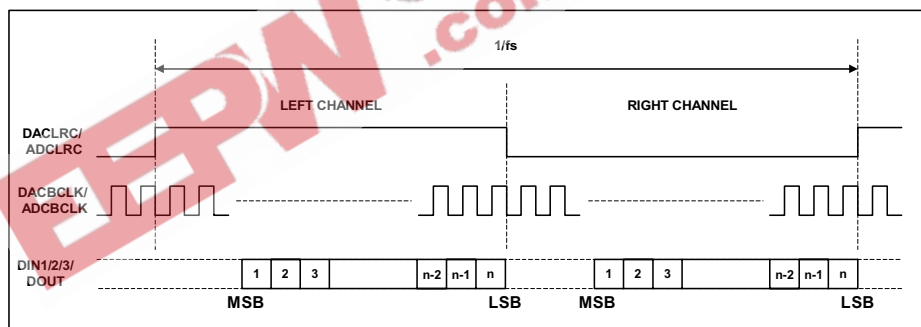

**Figure 44 Right Justified Mode Timing Diagram**

**I<sup>2</sup>S MODE**

In I<sup>2</sup>S mode, the MSB of DIN1/2/3 is sampled by the WM8772EFT on the second rising edge of BCLK following a DACLRC transition. The MSB of the ADC data is output on DOUT and changes on the first falling edge of BCLK following an ADCLRC transition and may be sampled on the rising edge of BCLK. ADCLRC and DACLRC are low during the left samples and high during the right samples.

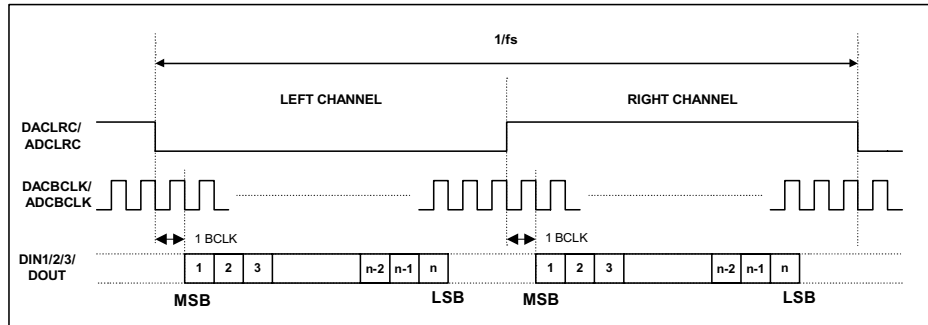

Figure 45 I<sup>2</sup>S Mode Timing Diagram

**DSP EARLY MODE**

In DSP early mode, the MSB of DAC channel 1 left data is sampled by the WM8772EFT on the second rising edge on DACBCLK following a DACLRC rising edge. DAC channel 1 right and DAC channels 2 and 3 data follow DAC channel 1 left data (Figure 46).

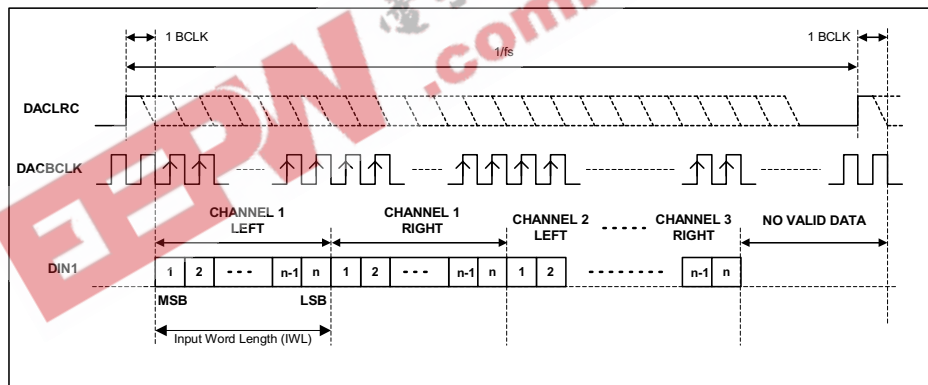

Figure 46 DSP Early Mode Timing Diagram – DAC Data Input

The MSB of the left channel ADC data is output on DOUT and changes on the first falling edge of ADCBCLK following a low to high ADCLRC transition and may be sampled on the rising edge of ADCBCLK. The right channel ADC data is contiguous with the left channel data (Figure 47)

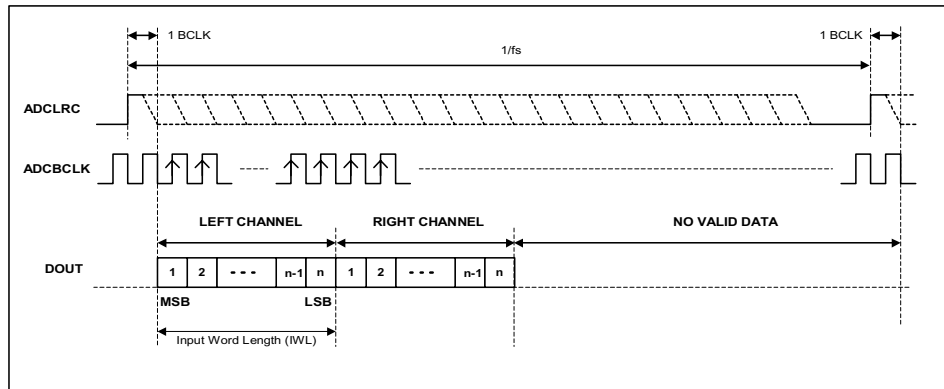

Figure 47 DSP Early Mode Timing Diagram – ADC Data Output

**DSP LATE MODE**

In DSP late mode, the MSB of DAC channel 1 left data is sampled by the WM8772EFT on the first DACBCLK rising edge following a DACLRC rising edge. DAC channel 1 right and DAC channels 2 and 3 data follow DAC channel 1 left data (Figure 48).

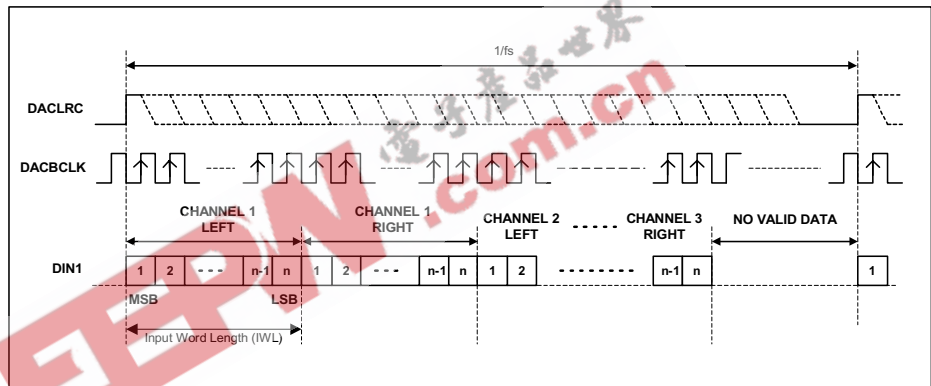

Figure 48 DSP Late Mode Timing Diagram – DAC Data Input

The MSB of the left channel ADC data is output on DOUT and changes on the same falling edge of ADCBCLK as the low to high ADCLRC transition and may be sampled on the rising edge of ADCBCLK. The right channel ADC data is contiguous with the left channel data (Figure 49).

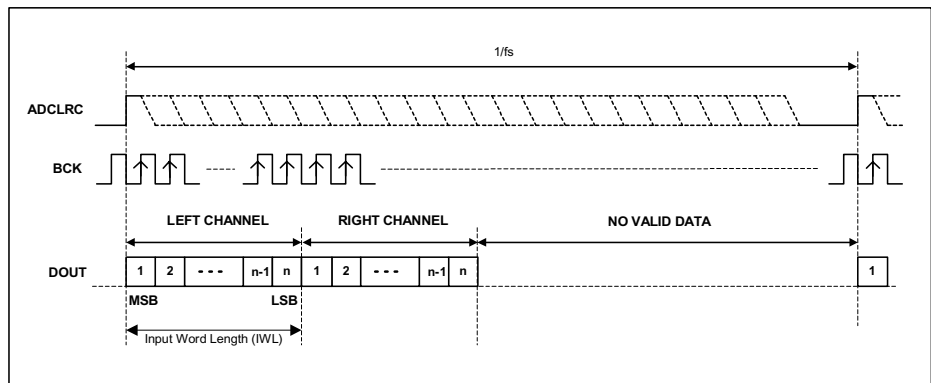

Figure 49 DSP Late Mode Timing Diagram – ADC Data Output

In both early and late DSP modes, DACL1 is always sent first, followed immediately by DACR1 and the data words for the other 6 channels. No BCLK edges are allowed between the data words. The word order is DAC1 left, DAC1 right, DAC2 left, DAC2 right, DAC3 left, DAC3 right.

## POWERDOWN MODES

The WM8772EFT has powerdown control bits allowing specific parts of the WM8772EFT to be powered off when not being used. Control bit ADCPD powers off the ADC. The three stereo DACs each have a separate powerdown control bit, DACPD[2:0] allowing individual stereo DACs to be powered off when not in use. Setting ADCPD and DACPD[2:0] will powerdown everything except the references VMID and REFADC. These may be powered down by setting PDWN. Setting PDWN will override all other powerdown control bits. It is recommended that the ADC and DACs are powered down before setting PDWN.

## ZERO DETECT

The WM8772EFT has a zero detect circuit for each DAC channel that detects when 1024 consecutive zero samples have been input. The MUTE pin output may be programmed to output the zero detect signal (see Table 10) which may then be used to control external muting circuits. A '1' on MUTE indicates a zero detect. The zero detect may also be used to automatically enable DAC mute by setting IZD.

DZFM[1:0]	MUTE
00	All channels zero
01	Channel 1 zero
10	Channel 2 zero
11	Channel 3 zero

Table 21 Zero Flag Output Select

## SOFTWARE CONTROL INTERFACE OPERATION

The WM8772EFT is controlled using a 3-wire serial interface in software mode or pin programmable in hardware mode.

The control mode is selected by the state of the MODE pin.

The control interfaces are 5V tolerant; meaning that the control interface input signals ML/I2S, MC/IWL and MD/DM may have an input high level of 5V while DVDD is 3V. Input thresholds are determined by DVDD. MUTE and MODE are also 5V tolerant.

### 3-WIRE (SPI COMPATIBLE) SERIAL CONTROL MODE

MD/DM is used for the program data, MC/IWL is used to clock in the program data and ML/I2S is used to latch the program data. MD/DM is sampled on the rising edge of MC/IWL. The 3-wire interface protocol is shown in Figure 30.

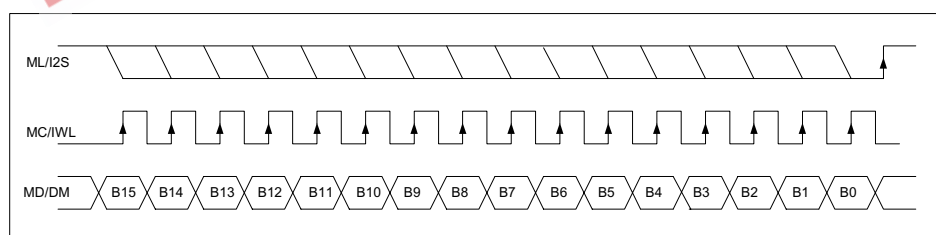

Figure 50 3-Wire SPI Compatible Interface

- B[15:9] are Control Address Bits
- B[8:0] are Control Data Bits
- ML/I2S is edge-sensitive – the data is latched on the rising edge of ML/I2S.

## REGISTER MAP – 32 PIN TQFP

The complete register map is shown below. The detailed description can be found in the relevant text of the device description. The WM8772EFT can be configured using the Control Interface. All unused bits should be set to '0'.

REGISTER	B15	B14	B13	B12	B11	B10	B9	B8	B7	B6	B5	B4	B3	B2	B1	B0	DEFAULT
R0(00h)	0	0	0	0	0	0	0	UPDATE	LDA1[7:0]								01111111
R1(01h)	0	0	0	0	0	0	1	UPDATE	RDA1[7:0]								01111111
R2(02h)	0	0	0	0	0	1	0	PL[8:5]			IZD	ATC	PDWN All DAC	DEEMP	MUTE All DAC	10010000	
R3(03h)	0	0	0	0	0	1	1	PHASE[8:6]		DACIWL[5:4]		DACBOP	DACLRP	DACFMT[1:0]		00000000	
R4(04h)	0	0	0	0	1	0	0	UPDATE	LDA2[7:0]								01111111
R5(05h)	0	0	0	0	1	0	1	UPDATE	RDA2[7:0]								01111111
R6(06h)	0	0	0	0	1	1	0	UPDATE	LDA3[7:0]								01111111
R7(07h)	0	0	0	0	1	1	1	UPDATE	RDA3[7:0]								01111111
R8(08h)	0	0	0	1	0	0	0	UPDATE	MASTDA[7:0]								01111111
R9(09h)	0	0	0	1	0	0	1	DEEMP[8:6]			DMUTE[5:3]		DZFM[2:1]		ZCD	00000000	
R10(0Ah)	0	0	0	1	0	1	0	DACRATE[8:6]			DACMS	PWRDN ALL	DACPD[3:1]		ADCPD	01000000	
R11(0Bh)	0	0	0	1	0	1	1	ADC OSR	ADCRATE[7:5]			ADCMS	ADCIWL[3:2]		ADCFMT[1:0]		00100000
R12(0Ch)	0	0	0	1	1	0	0	0	SYNC	MPD	ADCBOP	DACLRP	ADCHP	AMUTE ALL	AMUTEL	AMUTER	00000000
R31(1Fh)	0	0	1	1	1	1	1	RESET								00000000	

## CONTROL INTERFACE REGISTERS

## ATTENUATOR CONTROL MODE

Setting the ATC register bit causes the left channel attenuation settings to be applied to both left and right channel DACs from the next audio input sample. No update to the attenuation registers is required for ATC to take effect.

REGISTER ADDRESS	BIT	LABEL	DEFAULT	DESCRIPTION
0000010 DAC Channel Control	3	ATC	0	Attenuator Control Mode: 0: Right channels use right attenuations 1: Right channels use left attenuations

## INFINITE ZERO DETECT ENABLE

Setting the IZD register bit will enable the internal infinite zero detect function:

REGISTER ADDRESS	BIT	LABEL	DEFAULT	DESCRIPTION
0000010 DAC Channel Control	4	IZD	0	Infinite zero mute enable 0: Disable infinite zero mute 1: Enable infinite zero mute

With IZD enabled, applying 1024 consecutive zero input samples to each input will cause the relevant DAC to be muted to  $V_{MID}$ . Mute will be removed as soon as that channel receives a non-zero input.

## DAC OUTPUT CONTROL

The DAC output control word determines how the left and right inputs to the audio Interface are applied to the left and right DACs:

REGISTER ADDRESS	BIT	LABEL	DEFAULT	DESCRIPTION		
0000010 DAC Control	8:5	PL[3:0]	1001	PL[3:0]	Left Output	Right Output
				0000	Mute	Mute
				0001	Left	Mute
				0010	Right	Mute
				0011	(L+R)/2	Mute
				0100	Mute	Left
				0101	Left	Left
				0110	Right	Left
				0111	(L+R)/2	Left
				1000	Mute	Right
				1001	Left	Right
				1010	Right	Right
				1011	(L+R)/2	Right
				1100	Mute	(L+R)/2
				1101	Left	(L+R)/2
				1110	Right	(L+R)/2
1111	(L+R)/2	(L+R)/2				



## DAC DIGITAL AUDIO INTERFACE CONTROL REGISTER

Interface format is selected via the DACFMT[1:0] register bits:

REGISTER ADDRESS	BIT	LABEL	DEFAULT	DESCRIPTION
0000011 Interface Control	1:0	DACFMT [1:0]	00	Interface Format Select: 00 : Right justified mode 01: Left justified mode 10: I <sup>2</sup> S mode 11: DSP (early or late) mode

In left justified, right justified or I<sup>2</sup>S modes, the DACLRP register bit controls the polarity of DACLRC. If this bit is set high, the expected polarity of DACLRC will be the opposite of that shown Figure 23, Figure 24 and Figure 25. Note that if this feature is used as a means of swapping the left and right channels, a 1 sample phase difference will be introduced. In DSP modes, the DACLRP register bit is used to select between early and late modes.

REGISTER ADDRESS	BIT	LABEL	DEFAULT	DESCRIPTION
0000011 Interface Control	2	DACLRP	0	In Left/Right/I <sup>2</sup> S Modes: DACLRC Polarity (normal) 0 : Normal DACLRC polarity 1: Inverted DACLRC polarity  In DSP Mode: 0 : Early DSP mode 1: Late DSP mode

By default, DACLRC and DIN1/2/3 are sampled on the rising edge of DACBCLK and should ideally change on the falling edge. Data sources that change DACLRC and DIN1/2/3 on the rising edge of DACBCLK can be supported by setting the BCP register bit. Setting DACBCP to 1 inverts the polarity of DACBCLK to the inverse of that shown in Figure 23, Figure 24, Figure 25, Figure 26, Figure 27, Figure 28 and Figure 29.

REGISTER ADDRESS	BIT	LABEL	DEFAULT	DESCRIPTION
0000011 Interface Control	3	DACBCP	0	DACBCLK Polarity (DSP Modes) 0 : Normal BCLK polarity 1: Inverted BCLK polarity

The DACIWL[1:0] bits are used to control the input word length.

REGISTER ADDRESS	BIT	LABEL	DEFAULT	DESCRIPTION
0000011 Interface Control	5:4	DACIWL [1:0]	00	Input Word Length: 00 : 16 bit data 01: 20 bit data 10: 24 bit data 11: 32 bit data

**Note:** If 32-bit mode is selected in right justified mode, the WM8772EFT defaults to 24 bits.

In all modes, the data is signed 2's complement. The digital filters always input 24-bit data. If the DAC is programmed to receive 16 or 20 bit data, the WM8772EFT pads the unused LSBs with zeros. If the DAC is programmed into 32 bit mode, the 8 LSBs are ignored.

**Note:** In 24 bit I<sup>2</sup>S mode, any width of 24 bits or less is supported provided that DACLRC is high for a minimum of 24 BCLKs and low for a minimum of 24 BCLKs.

A number of options are available to control how data from the Digital Audio Interface is applied to the DAC channels.

**DAC OUTPUT PHASE**

The DAC Phase control word determines whether the output of each DAC is non-inverted or inverted

REGISTER ADDRESS	BIT	LABEL	DEFAULT	DESCRIPTION		
0000011 DAC Phase	8:6	PHASE [2:0]	000	Bit	DAC	Phase
				0	DAC1L/R	1 = invert
				1	DAC2L/R	1 = invert
				2	DAC3L/R	1 = invert

**DIGITAL ZERO CROSS-DETECT**

The Digital volume control also incorporates a zero cross detect circuit which detects a transition through the zero point before updating the digital volume control with the new volume. This is enabled by control bit DZCEN.

REGISTER ADDRESS	BIT	LABEL	DEFAULT	DESCRIPTION
0001001 DAC Control	0	ZCD	0	DAC Digital Volume Zero Cross Disable: 0: Zero cross detect enabled 1: Zero cross detect disabled

**MUTE FLAG OUTPUT**

The DZFM control bits allow the selection of the six DAC channel zero flag bits for output on the MUTE pin. A '1' on MUTE indicates 1024 consecutive zero input samples to the DAC channels selected.

REGISTER ADDRESS	BIT	LABEL	DEFAULT	DESCRIPTION
0001001 Zero Flag	2:1	DZFM[1:0]	00	Selects the output MUTE pin (A '1' indicates 1024 consecutive zero input samples on the DAC channels selected. 00: All channels zero 01: Channel 1 zero 10: Channel 2 zero 11: Channel 3 zero

**DAC MUTE MODES**

The WM8772EFT has individual mutes for each of the three DAC channels. Setting MUTE for a channel will apply a 'soft' mute to the input of the digital filters of the channel muted.

REGISTER ADDRESS	BIT	LABEL	DEFAULT	DESCRIPTION
0001001 DAC Mute	5:3	DMUTE [2:0]	000	DAC Soft Mute Select

DMUTE [2:0]	DAC CHANNEL 1	DAC CHANNEL 2	DAC CHANNEL 3
000	Not MUTE	Not MUTE	Not MUTE
001	MUTE	Not MUTE	Not MUTE
010	Not MUTE	MUTE	Not MUTE
011	MUTE	MUTE	Not MUTE
100	Not MUTE	Not MUTE	MUTE
101	MUTE	Not MUTE	MUTE
110	Not MUTE	MUTE	MUTE

Setting the MUTEALL register bit will apply a 'soft' mute to the input of all the DAC digital filters:

REGISTER ADDRESS	BIT	LABEL	DEFAULT	DESCRIPTION
0000010 DAC Mute	0	MUTEALL	0	Soft Mute Select: 0 : Normal operation 1: Soft mute all channels

Refer to Figure 39 for the plot of application and release of soft mute.

Note that all other means of muting the DAC channels: setting the PL[3:0] bits to 0, setting the PDWN bit or setting attenuation to 0 will cause much more abrupt muting of the output.

### ADC MUTE MODES

Each ADC channel also has a mute control bit, which mutes the inputs to the ADC.

REGISTER ADDRESS	BIT	LABEL	DEFAULT	DESCRIPTION
0001100 ADC Mute	0	AMUTER	0	ADC Mute Select: 0 : Normal operation 1: mute ADC right
	1	AMUTEL	0	ADC Mute Select: 0 : Normal operation 1: mute ADC left
	2	AMUTEALL	0	ADC Mute Select: 0 : Normal operation 1: mute both ADC channels

### DE-EMPHASIS MODE

Each stereo DAC channel has an individual de-emphasis control bit:

REGISTER ADDRESS	BIT	LABEL	DEFAULT	DESCRIPTION
0001001 DAC De-emphasis Control	[8:6]	DEEMPH [1:0]	000	De-emphasis Channel Selection Select:

DEEMPH [1:0]	DAC CHANNEL 1	DAC CHANNEL 2	DAC CHANNEL 3
000	Not DE-EMPHASIS	Not DE-EMPHASIS	Not DE-EMPHASIS
001	DE-EMPHASIS	Not DE-EMPHASIS	Not DE-EMPHASIS
010	Not DE-EMPHASIS	DE-EMPHASIS	Not DE-EMPHASIS
011	DE-EMPHASIS	DE-EMPHASIS	Not DE-EMPHASIS
100	Not DE-EMPHASIS	Not DE-EMPHASIS	DE-EMPHASIS
101	DE-EMPHASIS	Not DE-EMPHASIS	DE-EMPHASIS
110	Not DE-EMPHASIS	DE-EMPHASIS	DE-EMPHASIS

Refer to Figure 7, Figure 8, Figure 9, Figure 10, Figure 11 and Figure 12 for details of the De-Emphasis performance at different sample rates.

REGISTER ADDRESS	BIT	LABEL	DEFAULT	DESCRIPTION
0000010 DAC DEMP	1	DEEMP ALL	0	DEMMP Select: 0 : Normal operation 1: De-emphasis all channels

**POWERDOWN MODE AND ADC/DAC DISABLE**

Setting the PDWN register bit immediately powers down the DAC's on the WM8772EFT, overriding the DACD powerdown bits control bits. All trace of the previous input samples are removed, but all control register settings are preserved. When PDWN is cleared the digital filters will be reinitialised

REGISTER ADDRESS	BIT	LABEL	DEFAULT	DESCRIPTION
0000010 Powerdown Control	2	PDWN	0	Power Down all DAC's Select: 0: All DAC's enabled 1: All DAC's disabled

The ADC and DACs may also be powered down individually by setting the ADCPD and DACPD disable bits. Setting ADCD will disable the ADC and select a low power mode. The ADC digital filters will be reset and will reinitialise when ADCPD is unset. Each Stereo DAC channel has a separate disable DACPD[2:0]. Setting DACPD for a channel will disable the DACs and select a low power mode. Resetting DACD will reinitialise the digital filters.

REGISTER ADDRESS	BIT	LABEL	DEFAULT	DESCRIPTION
0001010 Powerdown Control	0	ADCPD	0	ADC Disable: 0: Active 1: Disable
	3:1	DACPD [2:0]	000	DAC Disable

DACPD [2:0]	DAC CHANNEL 1	DAC CHANNEL 2	DAC CHANNEL 3
000	Active	Active	Active
001	DISABLE	Active	Active
010	Active	DISABLE	Active
011	DISABLE	DISABLE	Active
100	Active	Active	DISABLE
101	DISABLE	Active	DISABLE
110	Active	DISABLE	DISABLE
111	DISABLE	DISABLE	DISABLE

**MASTER POWERDOWN**

This control bit powers down the references for the whole chop. Therefore for complete powerdown, both the ADC and DACs should be powered down first before setting this bit.

REGISTER ADDRESS	BIT	LABEL	DEFAULT	DESCRIPTION
0001010 Interface Control	4	PWRDNALL	0	Master Power Down Bit: 0: Not powered down 1: Powered down

**DAC MASTER MODE SELECT**

Control bit DACMS selects between audio interface Master and Slave Modes. In Master mode DACLRC and DACBCLK are outputs and are generated by the WM8772EFT. In Slave mode DACCLRC, DACLRC and DACBCLK are inputs to WM8772EFT.

REGISTER ADDRESS	BIT	LABEL	DEFAULT	DESCRIPTION
0001010 Interface Control	5	DACMS	0	DAC Audio Interface Master/Slave Mode Select: 0: Slave Mode 1: Master Mode

**MASTER MODE DACLRC FREQUENCY SELECT**

In Master mode the WM8772EFT generates DACLRC and DACBCLK. These clocks are derived from the master clock and the ratio of DACMCLK to DACLRC is set by DACRATE.

REGISTER ADDRESS	BIT	LABEL	DEFAULT	DESCRIPTION
0001010 Interface Control	8:6	DACRATE [2:0]	010	Master Mode DACMCLK:DACLRC Ratio Select: 000: 128fs 001: 192fs 010: 256fs 011: 384fs 100: 512fs 101: 768fs

**ADC DIGITAL AUDIO INTERFACE CONTROL REGISTER**

Interface format is selected via the ADCFMT[1:0] register bits:

REGISTER ADDRESS	BIT	LABEL	DEFAULT	DESCRIPTION
0001011 Interface Control	1:0	ADCFMT[1:0]	00	Interface Format Select 00: Right justified mode 01: Left justified mode 10: I <sup>2</sup> S mode 11: DSP (early or late) mode

The ADCIWL[1:0] bits are used to control the input word length.

REGISTER ADDRESS	BIT	LABEL	DEFAULT	DESCRIPTION
0001011 Interface Control	3:2	ADCIWL[1:0]	00	Input Word Length 00: 16 bit data 01: 20 bit data 10: 24 bit data 11: 32 bit data

**Note:** 32-bit right justified mode is not supported.

In all modes, the data is signed 2's complement.

**ADC MASTER MODE SELECT**

Control bit ADCMS selects between audio interface Master and Slave Modes. In Master mode ADCLRC and ADCBCLK are outputs and are generated by the WM8772EFT. In Slave mode ADCLRC and ADCBCLK are inputs to WM8772EFT.

REGISTER ADDRESS	BIT	LABEL	DEFAULT	DESCRIPTION
0001011 Interface Control	4	ADCMS	0	ADC Audio Interface Master/Slave Mode Select: 0: Slave mode 1: Master mode

**MASTER MODE ADCLRC FREQUENCY SELECT**

In Master mode the WM8772EFT generates ADCLRC and ADCBCLK. These clocks are derived from the master clock and the ratio of ADCMCLK to ADCLRC is set by ADCRATE.

REGISTER ADDRESS	BIT	LABEL	DEFAULT	DESCRIPTION
0001011 ADCLRC and ADCBCLK Frequency Select	7:5	ADCRATE [2:0]	010	Master Mode ADCMCLK:ADCLRC Ratio Select: 010: 256fs 011: 384fs 100: 512fs 101: 768fs

**ADC OVERSAMPLING RATE SELECT**

For ADC operation at 96kHz it is recommended that the user set the ADCOSR bit. This changes the ADC signal processing oversample rate to 64fs. The 64fs oversampling rate is only available in modes where a 96kHz rate is supported, i.e. 256fs or 384fs. In all other modes the ADC will stay in a 128fs oversampling rate irrespective of what this bit is set to.

REGISTER ADDRESS	BIT	LABEL	DEFAULT	DESCRIPTION
0001011 ADC Oversampling Rate	8	ADCOSR	0	ADC Oversampling Rate Select 0: 128x oversampling 1: 64x oversampling

**ADC HIGHPASS FILTER DISABLE**

The ADC digital filters contain a digital highpass filter. This defaults to enabled and can be disabled using software control bit ADCHPD.

REGISTER ADDRESS	BIT	LABEL	DEFAULT	DESCRIPTION
0001100 ADC Control	3	ADCHPD	0	ADC Highpass Filter Disable: 0: Highpass filter enabled 1: Highpass filter disabled

In left justified, right justified or I<sup>2</sup>S modes, the ADCLRP register bit controls the polarity of ADCLRC. If this bit is set high, the expected polarity of ADCLRC will be the opposite of that shown Figure 23, Figure 24 and Figure 25. Note that if this feature is used as a means of swapping the left and right channels, a 1 sample phase difference will be introduced. In DSP modes, the ADCLRP register bit is used to select between early and late modes.

REGISTER ADDRESS	BIT	LABEL	DEFAULT	DESCRIPTION
0001100 Interface Control	4	ADCLRP	0	In Left/Right/I <sup>2</sup> S Modes: ADCLRC Polarity (normal) 0: normal DACLRC polarity 1: inverted DACLRC polarity In DSP Mode: 0: Early DSP mode 1: Late DSP mode

By default, DACLRC and DOUT are sampled on the rising edge of ADCBCLK and should ideally change on the falling edge. Data sources that change ADCLRC and DOUT on the rising edge of ADCBCLK can be supported by setting the ADCBCP register bit. Setting ADCBCP to 1 inverts the polarity of ADCBCLK to the inverse of that shown in Figure 23, Figure 24, Figure 25, Figure 26, Figure 27, Figure 28 and Figure 29.

REGISTER ADDRESS	BIT	LABEL	DEFAULT	DESCRIPTION
0001100 Interface Control	5	ADCBCP	0	ADCCLK Polarity (DSP Modes): 0: normal BCLK polarity 1: inverted BCLK polarity

#### MUTE PIN DECODE

The MUTE pin can either be used an output or an input. When used as an input the MUTE pins action can controlled by setting the DZFM bit to select the corresponding DAC for applying the MUTE to. As an output its meaning is selected by the DZFM control bits. By default selecting the MUTE to represent if DAC1 has received more than 1024 midrail samples will cause the MUTE to be asserted a softmute on DAC1. Disabling the decode block will cause any logical high on the MUTE pin to apply a softmute to all DACs.

REGISTER ADDRESS	BIT	LABEL	DEFAULT	DESCRIPTION
0001100 ADC Control	6	MPD	0	MUTE Pin Decode Disable: 0: MUTE pin decode enable 1: MUTE pin decode disable

#### DAC TO ADC SYNC

If the DAC and ADC use the same MCLK, and they are operating in the same fs mode setting the SYNC bit will improve performance by synchronising the internal clock between the two blocks. Setting this at any other time may or may not improve or degrade the performance of the device.

REGISTER ADDRESS	BIT	LABEL	DEFAULT	DESCRIPTION
0001100 SYNC Control	7	SYNC	0	SYNC Function: 0: Disable 1: Enable

**DAC DIGITAL VOLUME CONTROL**

The DAC volume may also be adjusted in the digital domain using independent digital attenuation control registers

REGISTER ADDRESS	BIT	LABEL	DEFAULT	DESCRIPTION
0000000 Digital Attenuation DACL1	7:0	LDA1[7:0]	11111111 (0dB)	Digital Attenuation data for Left channel DACL1 in 0.5dB steps. See Table 11
	8	UPDATE	Not latched	Controls simultaneous update of all Attenuation Latches 0: Store LDA1 in intermediate latch (no change to output) 1: Store LDA1 and update attenuation on all channels
0000001 Digital Attenuation DACR1	7:0	RDA1[6:0]	11111111 (0dB)	Digital Attenuation data for Right channel DACR1 in 0.5dB steps. See Table 11
	8	UPDATE	Not latched	Controls simultaneous update of all Attenuation Latches 0: Store RDA1 in intermediate latch (no change to output) 1: Store RDA1 and update attenuation on all channels.
0000100 Digital Attenuation DACL2	7:0	LDA2[7:0]	11111111 (0dB)	Digital Attenuation data for Left channel DACL2 in 0.5dB steps. See Table 11
	8	UPDATE	Not latched	Controls simultaneous update of all Attenuation Latches 0: Store LDA2 in intermediate latch (no change to output) 1: Store LDA2 and update attenuation on all channels.
0000101 Digital Attenuation DACR2	7:0	RDA2[7:0]	11111111 (0dB)	Digital Attenuation data for Right channel DACR2 in 0.5dB steps. See Table 11
	8	UPDATE	Not latched	Controls simultaneous update of all Attenuation Latches 0: Store RDA2 in intermediate latch (no change to output) 1: Store RDA2 and update attenuation on all channels.
0000110 Digital Attenuation DACL3	7:0	LDA3[7:0]	11111111 (0dB)	Digital Attenuation data for Left channel DACL3 in 0.5dB steps. See Table 11
	8	UPDATE	Not latched	Controls simultaneous update of all Attenuation Latches 0: Store LDA3 in intermediate latch (no change to output) 1: Store LDA3 and update attenuation on all channels.
0000111 Digital Attenuation DACR3	7:0	RDA3[7:0]	11111111 (0dB)	Digital Attenuation data for Right channel DACR3 in 0.5dB steps. See Table 11
	8	UPDATE	Not latched	Controls simultaneous update of all Attenuation Latches 0: Store RDA3 in intermediate latch (no change to output) 1: Store RDA3 and update attenuation on all channels.
0001000 Master Digital Attenuation (all channels)	7:0	MASTDA [7:0]	11111111 (0dB)	Digital Attenuation data for all DAC channels in 0.5dB steps. See Table 11
	8	UPDATE	Not latched	Controls simultaneous update of all Attenuation Latches 0: Store gain in intermediate latch (no change to output) 1: Store gain and update attenuation on all channels.

L/RDAX[7:0]	ATTENUATION LEVEL
00(hex)	-∞ dB (mute)
01(hex)	-127dB
:	:
:	:
:	:
FE(hex)	-0.5dB
FF(hex)	0dB

Table 22 Digital Volume Control Attenuation Levels



**SOFTWARE REGISTER RESET**

Writing to register 11111 will cause a register reset, resetting all register bits to their default values. The device will be held in this reset state until a subsequent register write to any address is completed.

EEPW 电子產品世界  
.com.cn

## APPLICATIONS INFORMATION

## RECOMMENDED EXTERNAL COMPONENTS

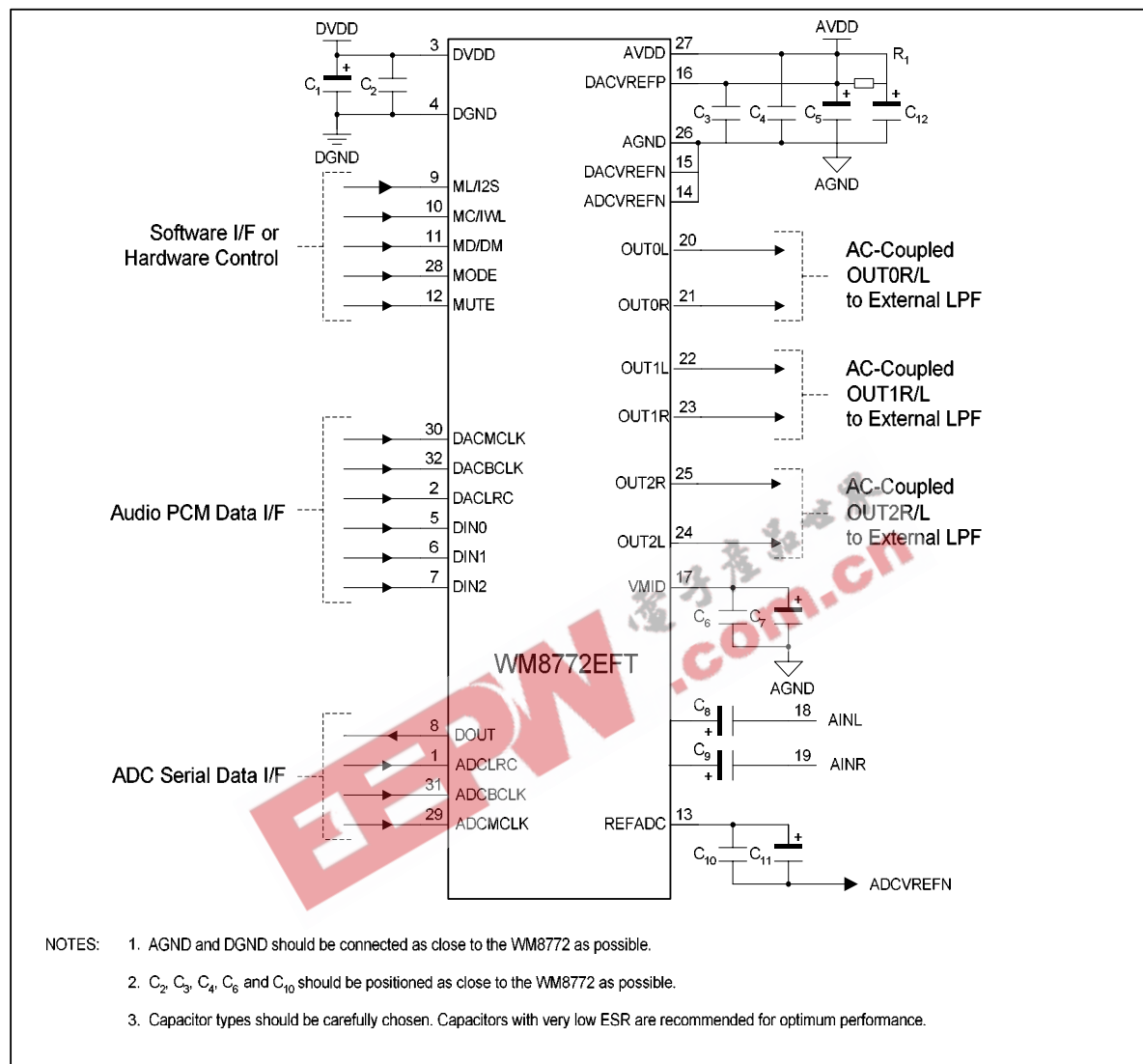

## RECOMMENDED EXTERNAL COMPONENTS VALUES

COMPONENT REFERENCE	SUGGESTED VALUE	DESCRIPTION
C1 and C5	10 $\mu$ F	De-coupling for DVDD and AVDD.
C2 to C4	0.1 $\mu$ F	De-coupling for DVDD and AVDD.
C8 and C9	1 $\mu$ F	Analogue input high pass filter capacitors
C6 and C10	0.1 $\mu$ F	Reference de-coupling capacitors for VMID and ADCREF pin.
C7 and C11	10 $\mu$ F	
C12	10 $\mu$ F	Filtering for VREFP. Omit if AVDD low noise.
R1	330 $\Omega$	Filtering for VREFP. Use 0 $\Omega$ if AVDD low noise.

Table 23 External Components Description

## SUGGESTED ANALOGUE LOW PASS POST DAC FILTERS

It is recommended that a lowpass filter be applied to the output from each DAC channel for Hi Fi applications. Typically a second order filter is suitable and provides sufficient attenuation of high frequency components (the unique low order, high bit count multi-bit sigma delta DAC structure used in WM8772EFT produces much less high frequency output noise than normal sigma delta DACs. This filter is typically also used to provide the 2x gain needed to provide the standard 2V<sub>rms</sub> output level from most consumer equipment.

Figure 51 shows a suitable post DAC filter circuit, with 2x gain. Alternative inverting filter architectures might also be used with as good results.

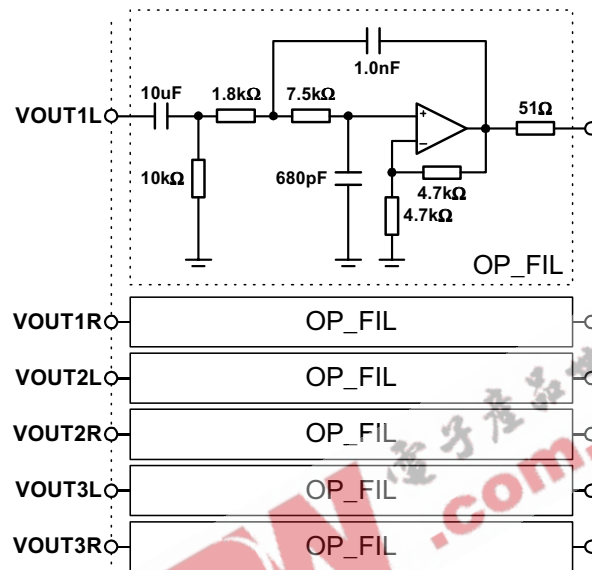

Figure 51 Recommended Post DAC Filter Circuit

To ensure that system 'pop' noise is kept to a minimum when power is applied or removed, a transistor clamp circuit arrangement may be added to the output connectors of the system. A recommended clamp circuit configuration is shown below.

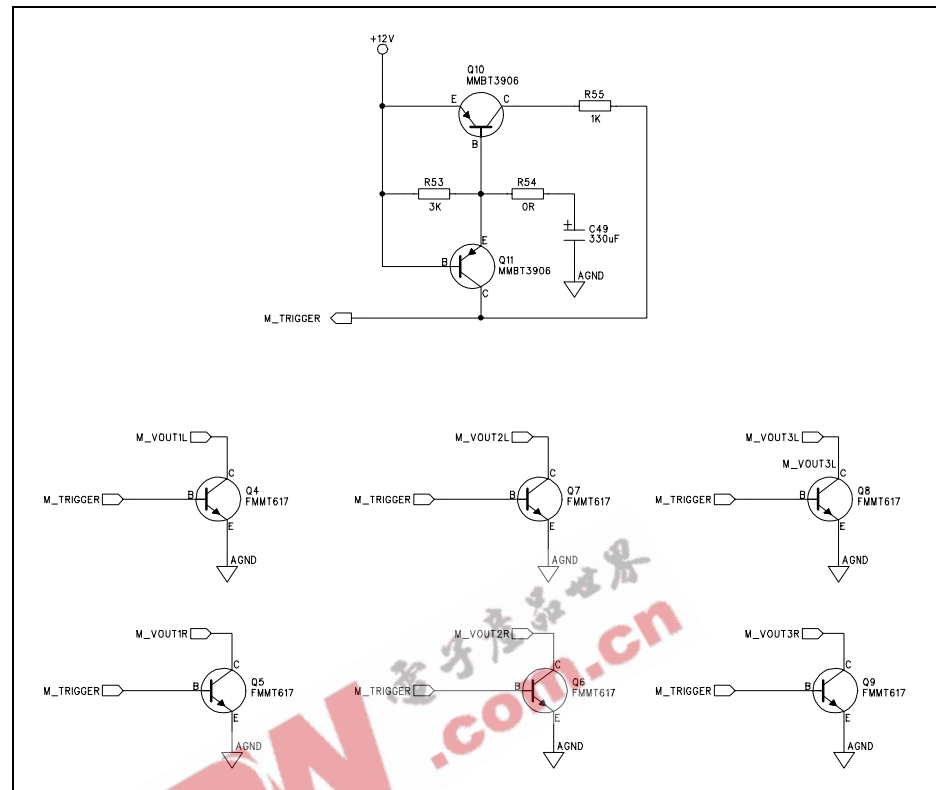

Figure 52 Output Clamp Circuit

When the +VS power supply is applied, PNP transistor Q10 of the trigger circuit is held on until capacitor C49 is fully charged. With transistor Q10 held 'on', NPN transistors Q4 to Q9 of the clamp circuits are also switched on holding the system outputs near to GND. When capacitor C49 is fully charged transistors Q10 and Q4 to Q9 are switched off setting the outputs active.

When the +VS power supply is removed, PNP transistor Q11 of the trigger circuit is switched on. In turn, transistors Q4 to Q9 of the clamp circuits are switched on holding the outputs of the evaluation board near to GND until the rest of the circuitry on the board has settled.

**Note:** It is recommended that low  $V_{ce_{sat}}$  switching transistors should be used in this circuit to ensure that the clamp is applied before the rest of the circuitry has time to power down.

**Important:** If a trigger circuit such as the one shown is to be used, it is important that the +VS supply drops quicker than any other supply to ensure that the outputs are clamped during the period when 'pop' noise may occur.

PACKAGE DIMENSIONS

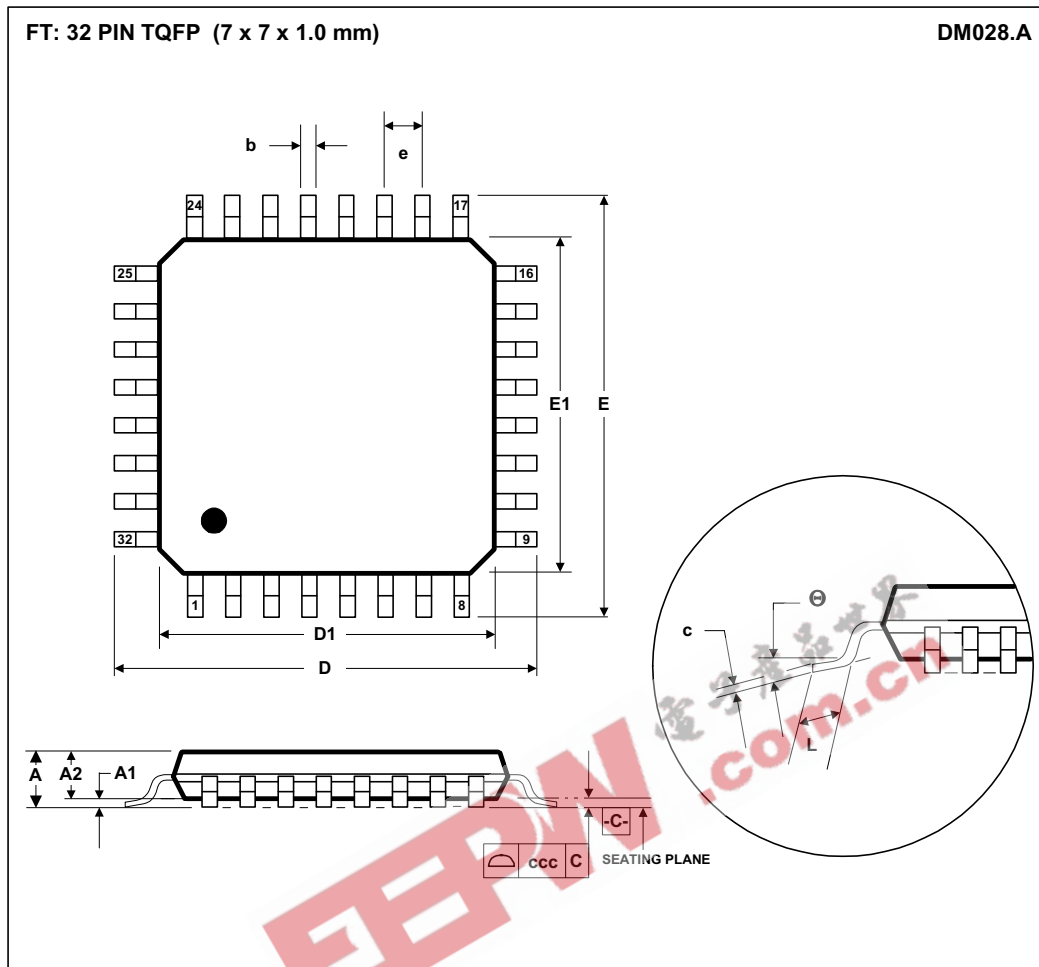

Symbols	Dimensions (mm)		
	MIN	NOM	MAX
A	----	----	1.20
A <sub>1</sub>	0.05	----	0.15
A <sub>2</sub>	0.95	1.00	1.05
b	0.30	0.37	0.45
c	0.09	----	0.20
D	9.00 BSC		
D <sub>1</sub>	7.00 BSC		
E	9.00 BSC		
E <sub>1</sub>	7.00 BSC		
e	0.80 BSC		
L	0.45	0.60	0.75
$\theta$	0°	3.5°	7°
Tolerances of Form and Position			
ccc	0.10		
REF:	JEDEC.95, MS-026		

- NOTES:  
 A. ALL LINEAR DIMENSIONS ARE IN MILLIMETERS.  
 B. THIS DRAWING IS SUBJECT TO CHANGE WITHOUT NOTICE.  
 C. BODY DIMENSIONS DO NOT INCLUDE MOLD FLASH OR PROTRUSION, NOT TO EXCEED 0.25MM.  
 D. MEETS JEDEC.95 MS-026, VARIATION = ABA. REFER TO THIS SPECIFICATION FOR FURTHER DETAILS.

## IMPORTANT NOTICE

Wolfson Microelectronics plc (WM) reserve the right to make changes to their products or to discontinue any product or service without notice, and advise customers to obtain the latest version of relevant information to verify, before placing orders, that information being relied on is current. All products are sold subject to the WM terms and conditions of sale supplied at the time of order acknowledgement, including those pertaining to warranty, patent infringement, and limitation of liability.

WM warrants performance of its products to the specifications applicable at the time of sale in accordance with WM's standard warranty. Testing and other quality control techniques are utilised to the extent WM deems necessary to support this warranty. Specific testing of all parameters of each device is not necessarily performed, except those mandated by government requirements.

In order to minimise risks associated with customer applications, adequate design and operating safeguards must be used by the customer to minimise inherent or procedural hazards. Wolfson products are not authorised for use as critical components in life support devices or systems without the express written approval of an officer of the company. Life support devices or systems are devices or systems that are intended for surgical implant into the body, or support or sustain life, and whose failure to perform when properly used in accordance with instructions for use provided, can be reasonably expected to result in a significant injury to the user. A critical component is any component of a life support device or system whose failure to perform can be reasonably expected to cause the failure of the life support device or system, or to affect its safety or effectiveness.

WM assumes no liability for applications assistance or customer product design. WM does not warrant or represent that any license, either express or implied, is granted under any patent right, copyright, mask work right, or other intellectual property right of WM covering or relating to any combination, machine, or process in which such products or services might be or are used. WM's publication of information regarding any third party's products or services does not constitute WM's approval, license, warranty or endorsement thereof.

Reproduction of information from the WM web site or datasheets is permissible only if reproduction is without alteration and is accompanied by all associated warranties, conditions, limitations and notices. Representation or reproduction of this information with alteration voids all warranties provided for an associated WM product or service, is an unfair and deceptive business practice, and WM is not responsible nor liable for any such use.

Resale of WM's products or services with statements different from or beyond the parameters stated by WM for that product or service voids all express and any implied warranties for the associated WM product or service, is an unfair and deceptive business practice, and WM is not responsible nor liable for any such use.

## ADDRESS:

Wolfson Microelectronics plc  
26 Westfield Road  
Edinburgh  
EH11 2QB  
United Kingdom

Tel :: +44 (0)131 272 7000

Fax :: +44 (0)131 272 7001

Email :: [sales@wolfsonmicro.com](mailto:sales@wolfsonmicro.com)