

FCX705

120V PNP SILICON HIGH VOLTAGE DARLINGTON TRANSISTOR

SUMMARY

$V_{CEO}=120V$; $V_{CE(sat)}= 1.3V$; $I_C= -1A$

DESCRIPTION

This new PNP Darlington transistor provides users with very efficient performance combining low $V_{CE(sat)}$ and very high H_{FE} to give extremely low on state losses at 120V operation. This makes it deal for use in a variety of efficient driving functions including motors, lamps relays and solenoids and will also benefit circuits requiring high output current switching.

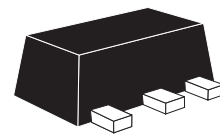

SOT89

FEATURES

- Low Saturation Voltage
- H_{FE} min 3K @ -1A
- $I_C= -2A$ Continuous
- SOT89 package with $P_{tot} - 1W$
- Specification is also available in Eline and SOT223 package outlines

APPLICATIONS

- Various driving functions
 - Lamps
 - Motors
 - Relays and solenoids
- High output current switches

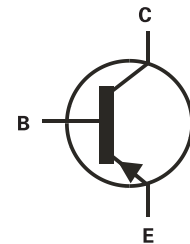

ORDERING INFORMATION

DEVICE	REEL SIZE	TAPE WIDTH	QUANTITY PER REEL
FCX705TA	7"	12mm	1000 units

DEVICE MARKING

705

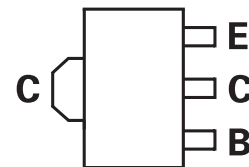

Top View

FCX705

ABSOLUTE MAXIMUM RATINGS.

PARAMETER	SYMBOL	LIMIT PNP	UNIT
Collector-Base Voltage	V_{CBO}	-140	V
Collector-Emitter Voltage	V_{CEO}	-120	V
Emitter-Base Voltage	V_{EBO}	-10	V
Peak Pulse Current	I_{CM}	-4	A
Continuous Collector Current	I_C	-1	A
Power Dissipation at $T_A=25^\circ\text{C}$ (a) Linear Derating Factor	P_D	1 8	W mW/ $^\circ\text{C}$
Power Dissipation at $T_A=25^\circ\text{C}$ (b) Linear Derating Factor	P_D	2.8 22	W mW/ $^\circ\text{C}$
Operating and Storage Temperature Range	$T_j:T_{stg}$	-55 to +150	$^\circ\text{C}$

THERMAL RESISTANCE

PARAMETER	SYMBOL	VALUE	UNIT
Junction to Ambient (a)	$R_{\theta JA}$	125	$^\circ\text{C}/\text{W}$
Junction to Ambient (b)	$R_{\theta JA}$	45	$^\circ\text{C}/\text{W}$

NOTES

- (a) For a device surface mounted on 25mm x 25mm FR4 PCB with high coverage of single sided 1oz copper, in still air conditions
(b) For a device surface mounted on FR4 PCB measured at $t \leq 5$ secs.

FCX705

ELECTRICAL CHARACTERISTICS (at $T_{amb} = 25^{\circ}\text{C}$ unless otherwise stated).

PARAMETER	SYMBOL	MIN.	TYP.	MAX.	UNIT	CONDITIONS.
Collector-Base Breakdown Voltage	$V_{(BR)CBO}$	-140			V	$I_C = -100\mu\text{A}$
Collector-Emitter Breakdown Voltage	$V_{(BR)CEO}$	-120			V	$I_C = -10\text{mA}^*$
Emitter-Base Breakdown Voltage	$V_{(BR)EBO}$	-10			V	$I_E = -100\mu\text{A}$
Collector Cut-Off Current	I_{CBO}			-100 -10	nA μA	$V_{CB} = -10\text{V}$ $V_{CB} = -120\text{V}$ $T_{amb} = 100^{\circ}\text{C}$
Emitter Cut-Off Current	I_{EBO}			-0.1	μA	$V_{EB} = -8\text{V}$
Collector Emitter Cut-Off Current	I_{CES}			-10	μA	$V_{CES} = -120\text{V}$
Collector-Emitter Saturation Voltage	$V_{CE(sat)}$			-1.3 -2.5	V V	$I_C = -1\text{A}, I_B = -1\text{mA}^*$ $I_C = -2\text{A}, I_B = -2\text{mA}^*$
Base-Emitter Saturation Voltage	$V_{BE(sat)}$			-1.8	V	$I_C = -1\text{A}, I_B = -1\text{mA}^*$
Base-Emitter Turn-On Voltage	$V_{BE(on)}$			-1.7	V	$I_C = -1\text{A}, V_{CE} = -5\text{V}^*$
Static Forward Current Transfer Ratio	h_{FE}	3K 3K 3K 2K		30K		$I_C = -10\text{mA}, V_{CE} = -5\text{V}^*$ $I_C = -100\text{mA}, V_{CE} = -5\text{V}^*$ $I_C = -1\text{A}, V_{CE} = -5\text{V}^*$ $I_C = -2\text{A}, V_{CE} = -5\text{V}^*$
Transition Frequency	f_T		160		MHz	$I_C = -100\text{mA}, V_{CE} = -10\text{V}$ $f = 20\text{MHz}$
Input Capacitance	C_{ibo}		90		pF	$V_{CB} = -500\text{mV}, f = 1\text{MHz}$
Output Capacitance	C_{obo}		15		pF	$V_{CB} = -10\text{V}, f = 1\text{MHz}$
Turn-On Time	$t_{(on)}$		0.6		μs	$I_C = -500\text{mA}, V_{CE} = -10\text{V}$ $I_{B1} = I_{B2} = -0.5\text{mA}$
Turn-Off Time	$t_{(off)}$		0.8		μs	$I_C = -500\text{mA}, V_{CE} = -10\text{V}$ $I_{B1} = I_{B2} = -0.5\text{mA}$

*Measured under pulsed conditions. Pulse width=300 μs . Duty cycle $\leq 2\%$
Nb. Spice parameter data is available upon request for this device.

FCX705

PNP CHARACTERISTICS

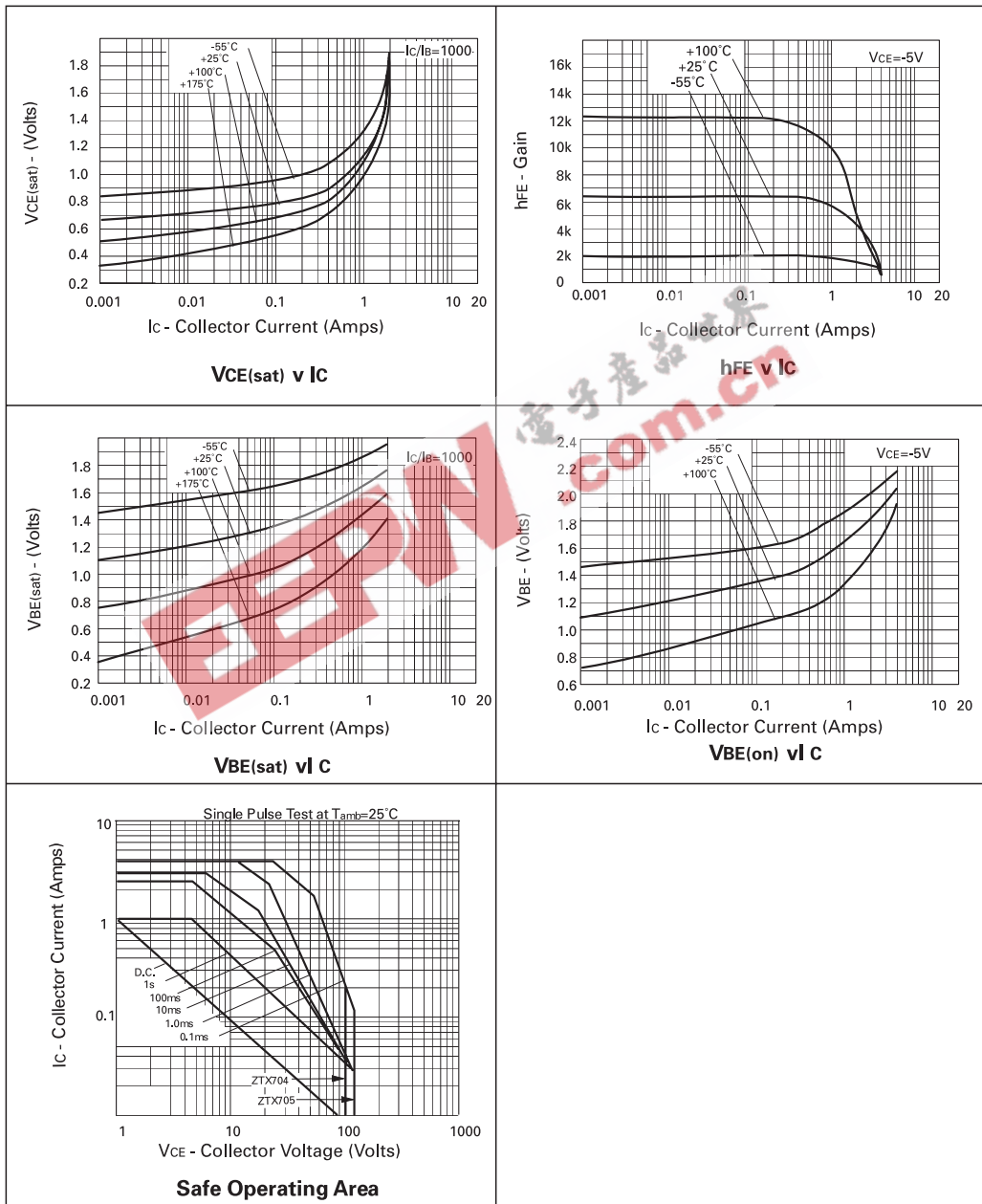

FCX705

PACKAGE DIMENSIONS

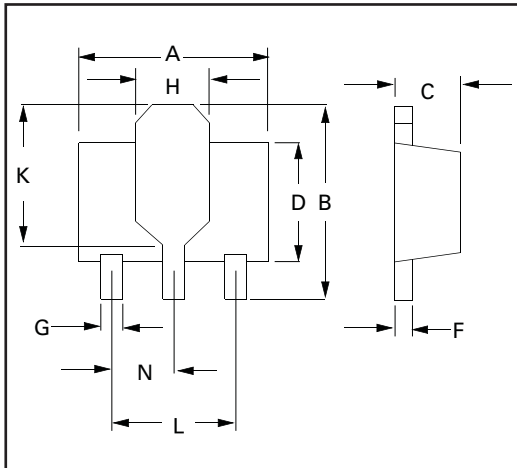

PAD LAYOUT DETAILS

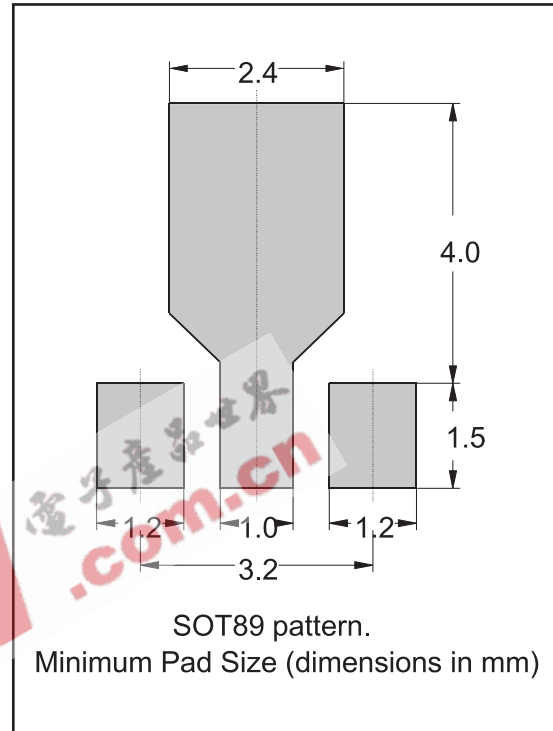

DIM	Millimetres		Inches	
	Min	Max	Min	Max
A	4.40	4.60	0.173	0.181
B	3.75	4.25	.150	0.167
C	1.40	1.60	0.550	0.630
D	-	2.60	-	0.102
F	0.28	0.45	0.011	0.018
G	0.38	0.55	0.015	0.022
H	1.50	1.80	0.060	0.072
K	2.60	2.85	0.102	0.112
L	2.90	3.10	0.114	0.112
N	1.4	1.60	0.055	0.063

© Zetex plc 2003

Europe

Zetex plc
Fields New Road
Chadderton
Oldham, OL9 8NP
United Kingdom
Telephone (44) 161 622 4444
Fax: (44) 161 622 4446
hq@zetex.com

Zetex GmbH
Streitfeldstraße 19
D-81673 München

Germany
Telefon: (49) 89 45 49 49 0
Fax: (49) 89 45 49 49 49
europe.sales@zetex.com

Americas

Zetex Inc
700 Veterans Memorial Hwy
Hauppauge, NY 11788

USA
Telephone: (1) 631 360 2222
Fax: (1) 631 360 8222
usa.sales@zetex.com

Asia Pacific

Zetex (Asia) Ltd
3701-04 Metroplaza Tower 1
Hing Fong Road
Kwai Fong
Hong Kong
Telephone: (852) 26100 611
Fax: (852) 24250 494
asia.sales@zetex.com

These offices are supported by agents and distributors in major countries world-wide.

This publication is issued to provide outline information only which (unless agreed by the Company in writing) may not be used, applied or reproduced for any purpose or form part of any order or contract or be regarded as a representation relating to the products or services concerned. The Company reserves the right to alter without notice the specification, design, price or conditions of supply of any product or service.

For the latest product information, log on to www.zetex.com

ISSUE 4 - DECEMBER 2002