



9-Line SCSI Bus Terminators

FEATURES

- Auto Selection of S/E or LVD SCSI Termination
- 2.7-V to 5.25-V TERMPWR Range
- Meets SCSI-1, SCSI-2, SPI-2 (ULTRA-2), SPI-3 (ULTRA-160) and SPI-4 (ULTRA-320) Standards
- Differential Failsafe Bias
- Thermal Package
- On-Chip Thermal Shutdown Circuit
- Master/Slave Input
- Active Negation
- Hot Swap Compatible

- Pin Compatible with UCC5630 and UCC5670
- Lead (Pb)-Free QSOP-36 Package

APPLICATIONS

- Disk Array (RAID)
- Storage Area Networks (SAN)
- Network Attached Storage (NAS)
- SCSI Cable
- Server and Workstation
- Industrial Computers
- High-End Personal Computers

DESCRIPTION

The SiP5630 provides active bus termination suitable for all SCSI bus operational modes from SCSI-1 through SPI-4 (Ultra 320). The termination includes impedance matching of the SCSI bus to minimize signal reflections from the end of the bus, as well as required SCSI bus biasing for either S/E (Single Ended) or LVD (Low Voltage Differential) operation.

The SiP5630 senses the operational state of the SCSI bus via the DIFFSENS bus signal, and automatically switches to S/E or LVD operation as required. It cannot be used on an HPD (High Power Differential) SCSI bus, and goes into high impedance mode when the voltage on the DIFFSENS line indicates HPD operation. The SiP5630 also presents high impedance to the SCSI bus if the DISABLE pin is asserted, or if TERMPWR is removed from the IC.

The SiP5630 has nine (9) output channels (T1-T9). Each output channel provides termination for one SCSI data signal, parity signal or control signal. Two SiP5630 ICs provide complete termination for a narrow SCSI Bus; three ICs provide complete termination for a wide SCSI bus.

The SiP5630 is available in a lead (Pb)-free QSOP-36 package for operation over the temperature range of 0 to 70°C.

FUNCTIONAL BLOCK DIAGRAM

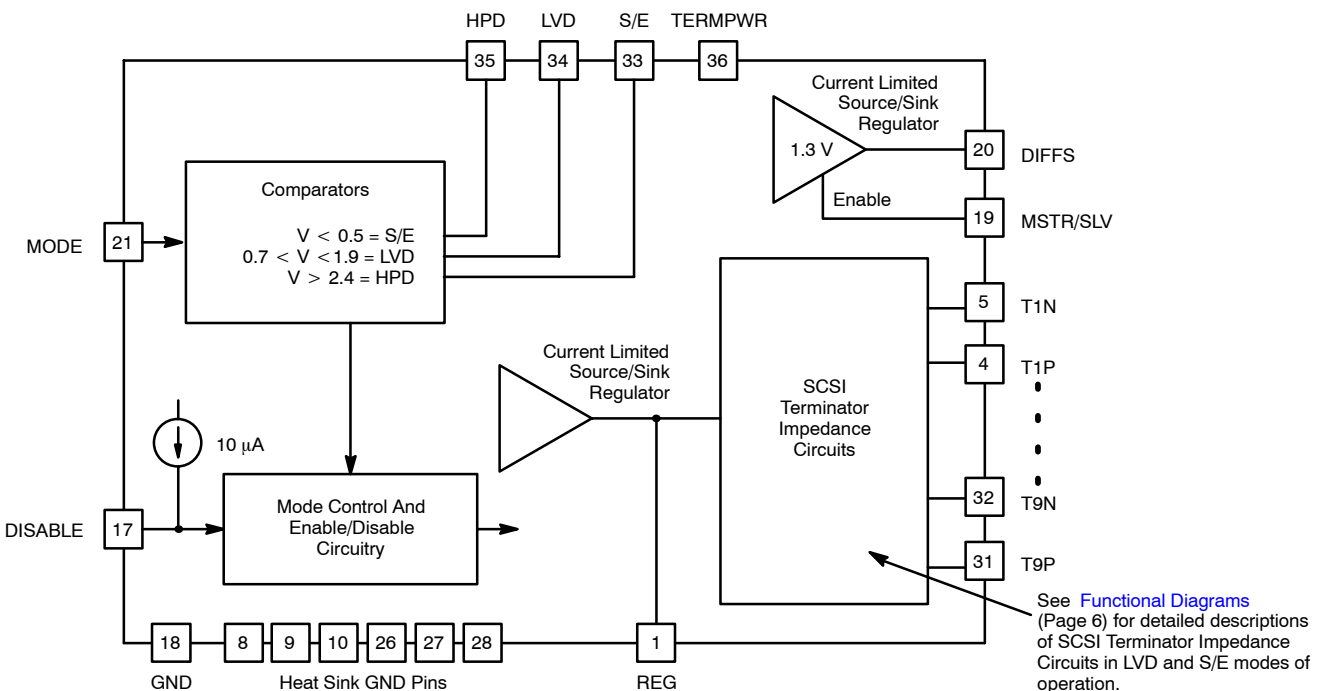

TYPICAL APPLICATION DIAGRAM

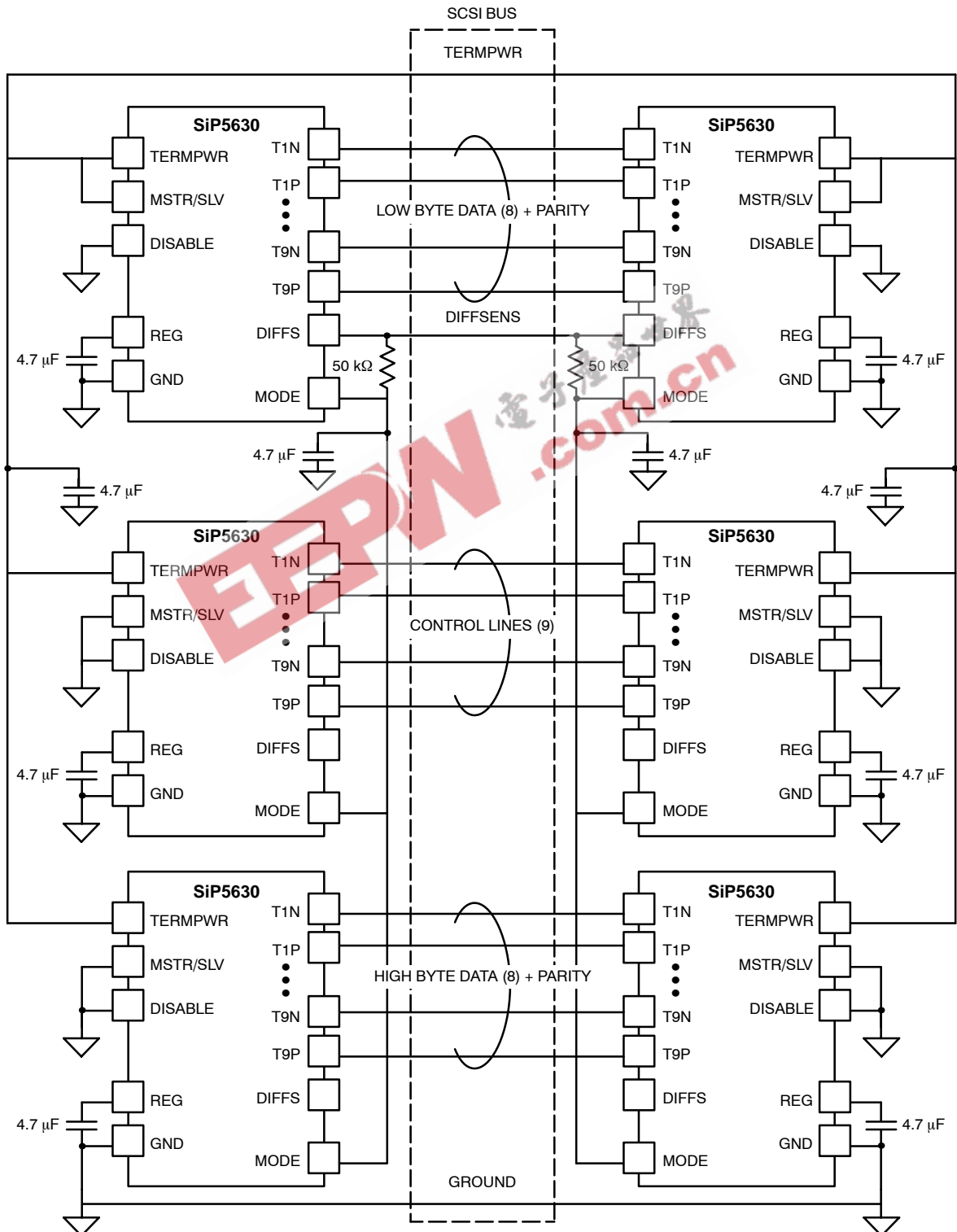



ABSOLUTE MAXIMUM RATINGS (ALL VOLTAGES REFERENCED TO GND = 0 V)

TERMPWR	6 V	Storage Temperature	-65 to 125 °C
TXN, TXP	-0.3 to 6 V	Junction Temperature	150 °C
MODE, DISABLE, M/S, STATUS	-0.3 to 6 V		

Stresses beyond those listed under "Absolute Maximum Ratings" may cause permanent damage to the device. These are stress ratings only, and functional operation of the device at these or any other conditions beyond those indicated in the operational sections of the specifications is not implied. Exposure to absolute maximum rating conditions for extended periods may affect device reliability.

RECOMMENDED OPERATING RANGE (ALL VOLTAGES REFERENCED TO GND = 0 V)

TERMPWR	2.7 V to 5.25 V	Operating Temperature Range (T _A)	0 to 70 °C
---------------	-----------------	---	------------

SPECIFICATIONS							
Parameter	Symbol	Test Conditions Unless Specified TERMPWR = 2.7 to 5.25 V, DISABLE = 0 V T _A = T _J = 0 to 70 °C	Limits			Unit	
			Min ^a	Typ ^b	Max ^a		
SCSI Channels (T1 to T9), LVD Operation							
Differential Impedance	Z _{DIFF}	MODE = 1.3 V	100	105	110	Ω	
Common Mode Impedance	Z _{CM}		120	140	160		
Differential Failsafe Bias	V _{DIFF}		100	112	125	mV	
Common Mode Bias	V _{CM}		1.15	1.25	1.35	V	
SCSI Channels (T1 to T9), S/E Operation							
Impedance	Z _{S/E}	MODE = 0 V	100	108	116	Ω	
Bias Voltage	V _{S/E}		2.5	2.7	3.0	V	
Output Current	I _{S/E}	MODE = 0 V	Channel Voltage = 0.2 V	-25.4	-23	-20.5	mA
			Channel Voltage = 0.5 V	-22.4			
GND Driver Impedance	Z _{GS}	MODE = 0 V, I _{TEST} = 10 mA		30	60	Ω	
SCSI Channels (T1 to T9), Termination Disabled							
Channel Leakage ^c	I _L	Channel Voltage = 0 to 5 V	-500	0	500	nA	
Channel Capacitance ^{c, d}	C _T	Referenced to GND		3		pF	
SCSI Regulator, LVD Mode							
Output Voltage	REG _(LVD)	0.5 V ≤ V _{CM} ≤ 2.0 V ^e	1.15	1.25	1.35	V	
Source Current	I _{SO(LVD)}	REG = 0 V	-800	-450	-250	mA	
Sink Current	I _{SI(LVD)}	REG = 4 V	200	300	800		
SCSI Regulator, S/E Mode							
Output Voltage	REG _(S/E)	0.2 V ≤ V _{CM} ≤ 4.0 V ^f	2.5	2.7	3.0	V	
Source Current	I _{SO(S/E)}	REG = 0 V	-800	-450	-250	mA	
Sink Current	I _{SI(S/E)}	REG = 4 V	200	300	800		
DIFFSENS Regulator							
Output Voltage	V _{DIFFS}	-5 mA ≤ I _{DIFFS} ≤ 50 μA	1.2	1.3	1.4	V	
Source Current	I _{SO(DIFFS)}	V _{DIFFS} = 0 V	-15	-8	-5	mA	
Sink Current	I _{SI(DIFFS)}	V _{DIFFS} = 2.75 V	50	100	200	μA	
DISABLE Input							
Input Threshold	V _{TH(DIS)}		0.8	1.0	1.2	V	
Input Current	I _{IN(DIS)}	0 V ≤ V _{DISABLE} ≤ 1.2 V	-30	-10	-3	μA	
		V _{DISABLE} > 1.2 V	-30	0	10		



SPECIFICATIONS						
Parameter	Symbol	Test Conditions Unless Specified TERMPWR = 2.7 to 5.25 V, DISABLE = 0 V $T_A = T_J = 0 \text{ to } 70 \text{ }^\circ\text{C}$	Limits			Unit
			Min ^a	Typ ^b	Max ^a	
MODE Input						
S/E to LVD Threshold	$V_{TH(S/E)}$		0.5	0.6	0.7	V
LVD to HPD Threshold	$V_{TH(HPD)}$		1.9	2.1	2.4	
Input Current	$I_{IN(MODE)}$	$0 \text{ V} \leq V_{MODE} \leq 5.25 \text{ V}$	-1	0	1	μA
MASTER/SLAVE Input						
Input Threshold	$V_{TH(M/S)}$	TERMPWR = 2.7 V	0.8	1.4	1.9	V
		TERMPWR = 3.3 V	1	1.7	2.3	
		TERMPWR = 5.25 V	1.5	2.6	3.7	
Input Current	$I_{IN(M/S)}$	$0 \text{ V} \leq V_{M/S} \leq \text{TERMPWR}$	-1	0	1	μA
STATUS Output Pins (LVD, S/E and HPD)						
Source Current	$I_{SO(STAT)}$	TERMPWR = 2.7 V, $V_{PIN} = 2.4 \text{ V}$		-10	-5	mA
Sink Current	$I_{SI(STAT)}$	$V_{PIN} = 0.4 \text{ V}$	3	6		
THERMAL Shutdown						
Shutdown Temperature ^d	T_{OFF}	Rising Temperature		160		$^\circ\text{C}$
Hysteresis ^d	T_{HYS}			10		
TERMPWR Supply						
LVD Mode	$I_{DD(LVD)}$	MODE = 1.3 V, Channels Unloaded		20	30	mA
S/E Mode	$I_{DD(S/E)}$	MODE = 0 V, Channels Unloaded		10	20	
HPD Mode	$I_{DD(HPD)}$	MODE = 3 V		10	20	
Disabled Mode	$I_{DD(DIS)}$	DISABLE = 3 V		500	1000	μA

Notes

- The algebraic convention whereby the most negative value is a minimum and the most positive a maximum is used in this data sheet.
- Typical values are for DESIGN AID ONLY, not guaranteed nor subject to production testing.
- MODE = 3 V and/or DISABLE = 3 V and/or TERMPWR = 0 V.
- Guaranteed by design, not subject to production test.
- V_{CM} applied simultaneously to Line PLUS and Line MINUS pins of all SCSI channels T1-T9.
- V_{CM} applied simultaneously to Line MINUS pins of all SCSI channels T1-T9.



PIN CONFIGURATION AND ORDERING INFORMATION

SiP5630 (QSOP-36)

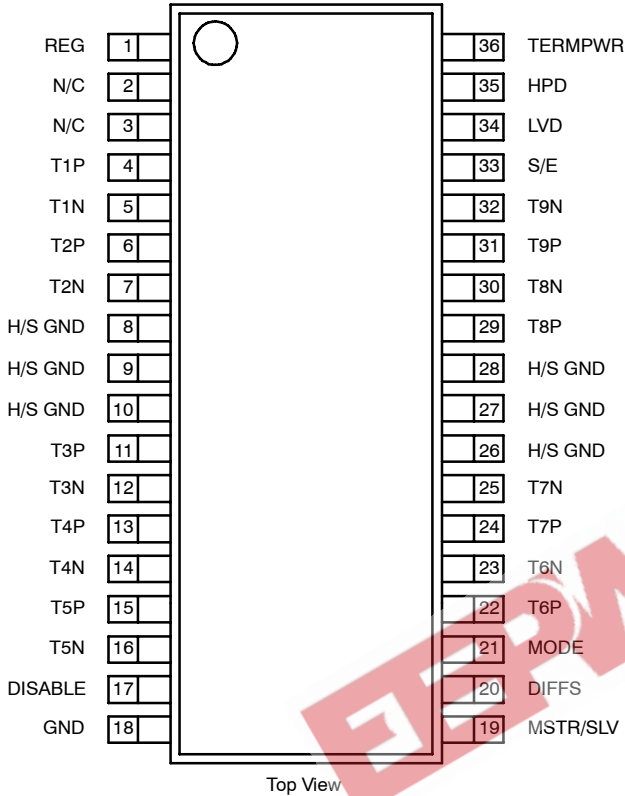

ORDERING INFORMATION

Part Number	Temperature Range	Marking
SiP5630CG-T1—E3	0 to 70°C	SiP5630CG

PIN DESCRIPTION		
Pin	Name	Function
1	REG	SCSI Regulator Output. Connect a 4.7- μ F bypass capacitor from this pin to GND.
2, 3	N/C	No Connect.
4, 6, 11, 13, 15, 22, 24, 29, 31	TXP; X = 1...9	Positive Terminator Channel Pins. Provide positive signal line termination in LVD operation, and are connected to GND through low impedance in S/E operation. In HPD, DISABLE, or Power Off condition these pins present high impedance to the SCSI Bus.
5, 7, 12, 14, 16, 23, 25, 30, 32	TXN; X = 1...9	Negative Terminator Channel Pins. Provide negative signal line termination in LVD operation, and line termination for S/E operation. In HPD, DISABLE, or Power Off condition these pins present high impedance to the SCSI Bus.
8, 9, 10, 26, 27, 28	H/S GND	Heat Sink Ground. Should be connected to as large a grounded heat sink area on the PC board as is practical.
17	DISABLE	Chip Disable. There is a small (nominal 10 μ A) pull up current on this pin. Pull this pin to GND to enable Bus Termination. When this pin is left floating or pulled high all SCSI channel pins present high impedance to the SCSI Bus, and the SCSI Regulator and DIFFSENS regulator are both disabled.
18	GND	Electrical ground connection for the terminator IC. Connect to the ground lines of the SCSI Bus
19	MSTR/SLV	Master/Slave. If this pin is tied to TERMPWR the output of the 1.3-V regulator for DIFFSENS is enabled. If this pin is tied to GND the output of the 1.3-V regulator for DIFFSENS is inhibited.
20	DIFFS	DIFFSENS Regulator Output. Connect to the DIFFSENS line of the SCSI Bus to bias the mode selection function.
21	MODE	SCSI MODE Select Pin. Connect to the DIFFSENS line of the SCSI Bus to sense the present mode of operation on the Bus. Decouple MODE from the DIFFSENS signal with a 50-k Ω /4.7 μ F low pass filter to meet SPI-3 mode change requirements.
33, 34, 35	S/E, LVD, HPD	Status Output Pins. Respective pins are high when the terminator detects the corresponding mode of operation on the SCSI Bus, and low otherwise.
36	TERMPWR	Power for the Terminator IC. Connect to the TERMPWR lines on the SCSI Bus and decouple with a 4.7- μ F capacitor to GND at the IC.



FUNCTIONAL BLOCK DIAGRAM—LVD OPERATION

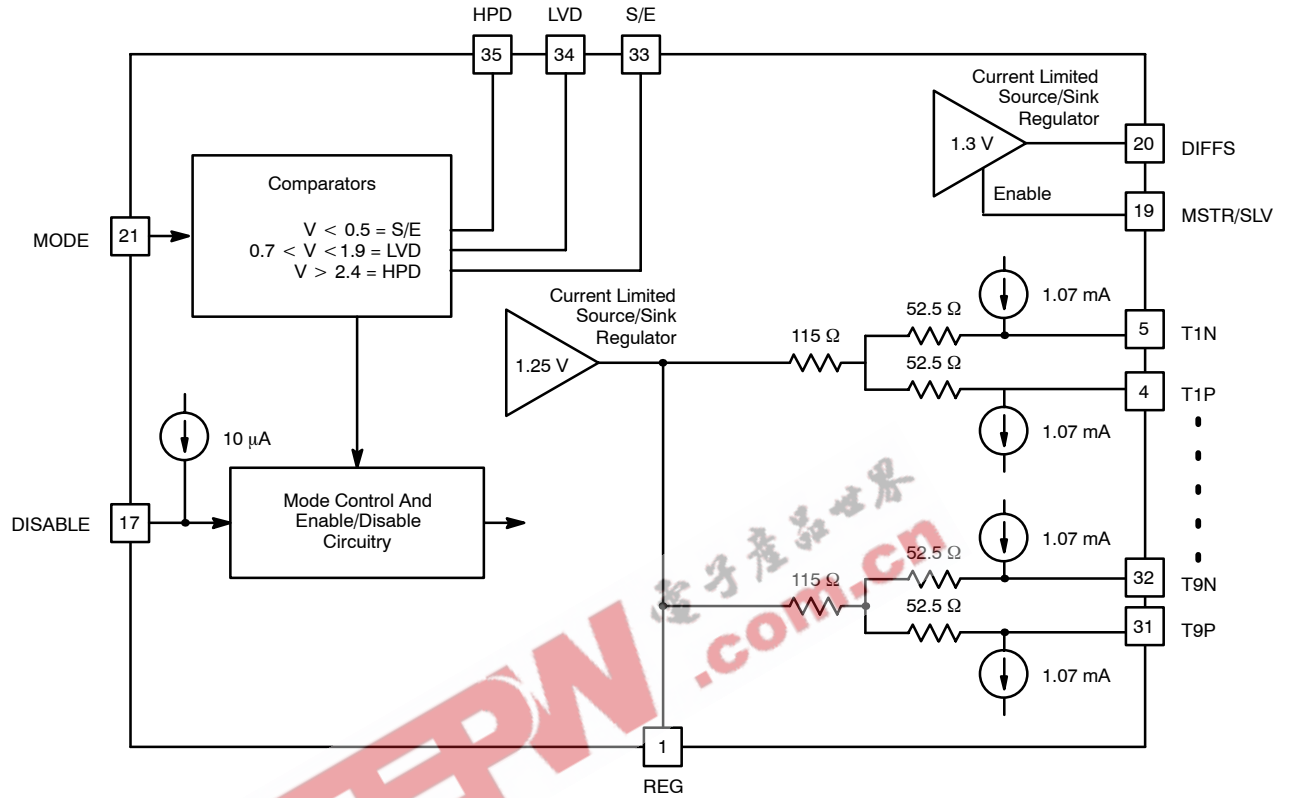

FUNCTIONAL BLOCK DIAGRAM—S/E OPERATION

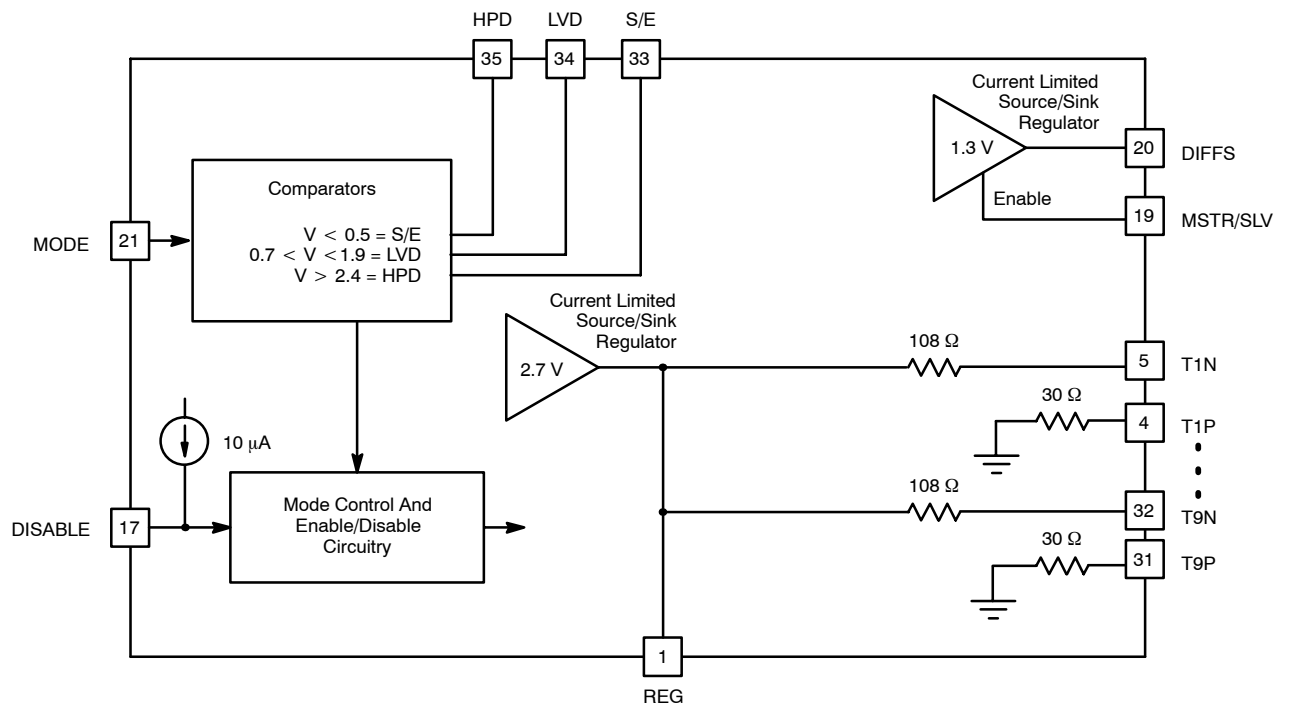



LVD WAVEFORMS

160 Mbyte/sec data transfer. Top panel DB10 T- and T+ signals. Bottom panel DB9 T- and T+ signals. All bits except DB9 toggling at maximum data rate.

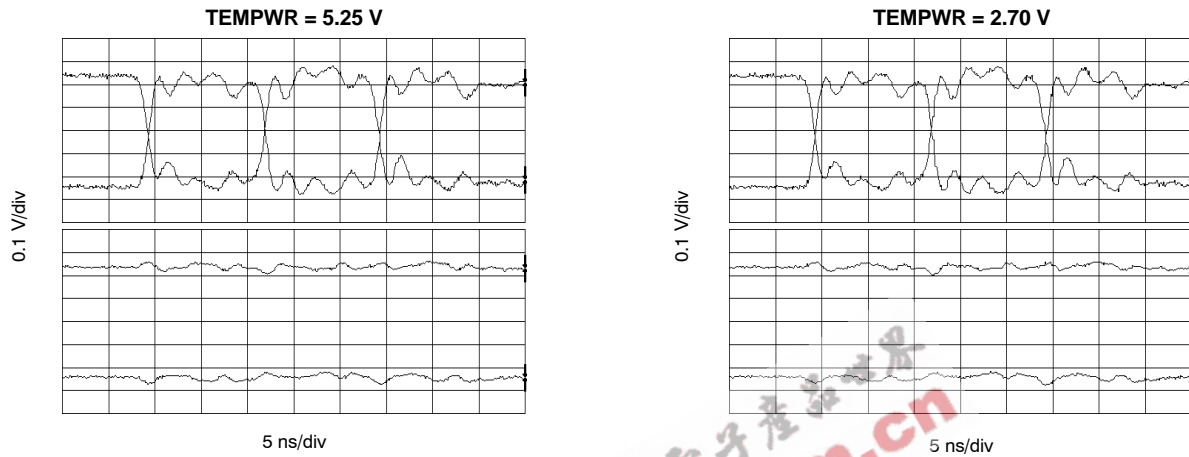

S/E WAVEFORMS

40 Mbyte/sec data transfer. Top panel DB10 T- signals. Bottom panel DB9 T- signals.

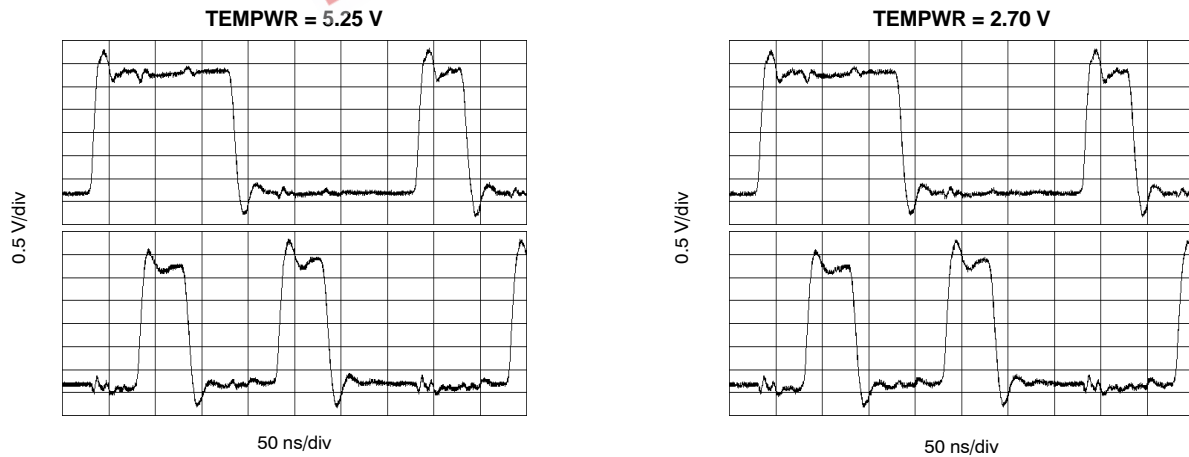



LVD TYPICAL CHARACTERISTICS

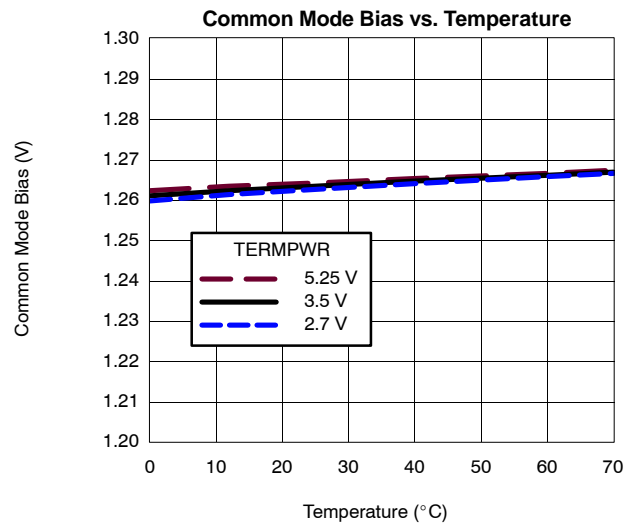
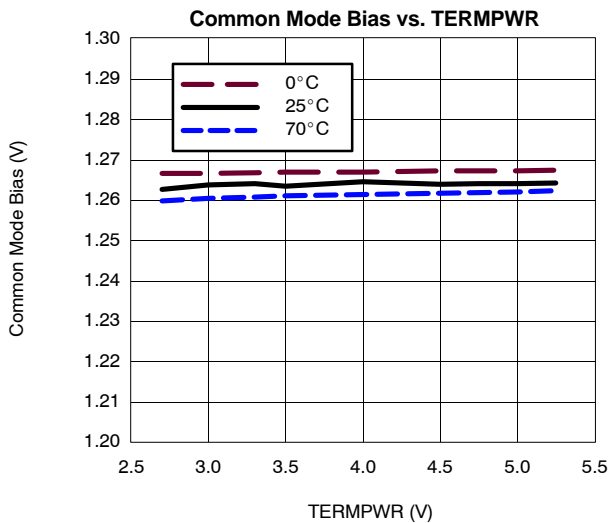
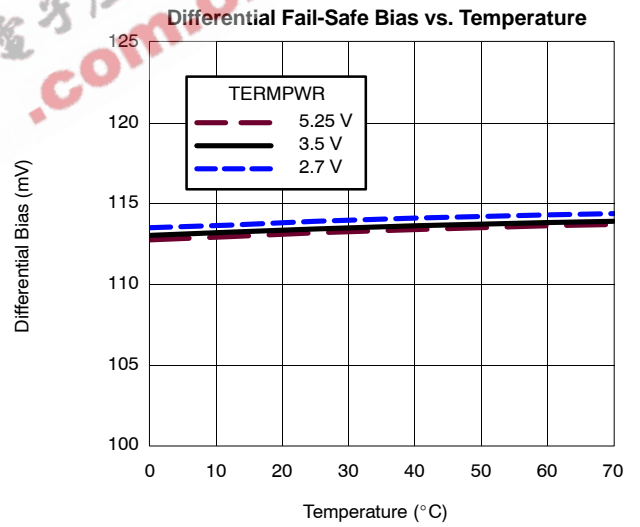
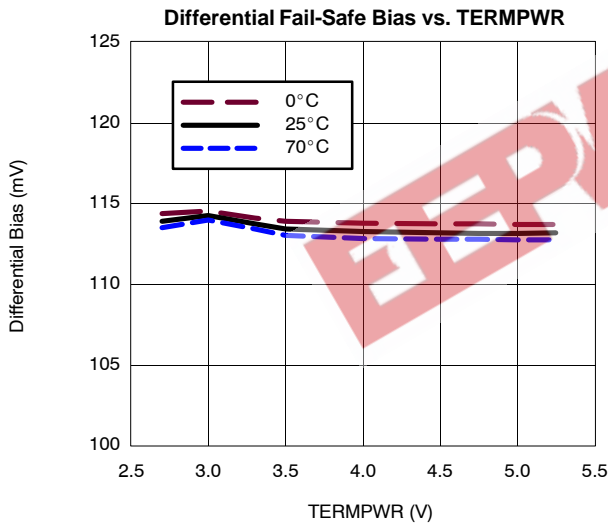
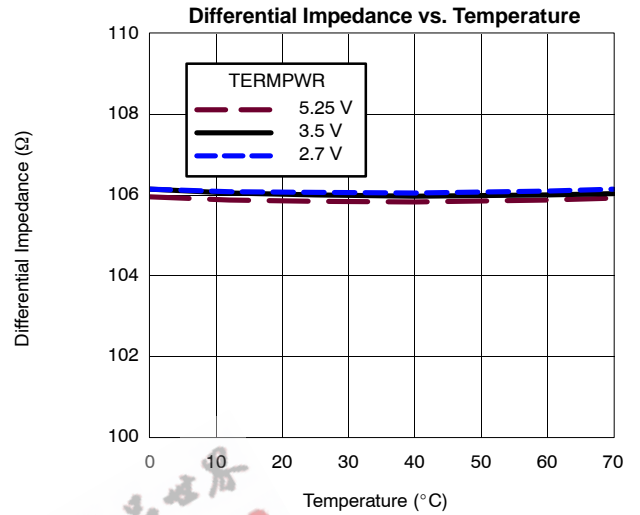
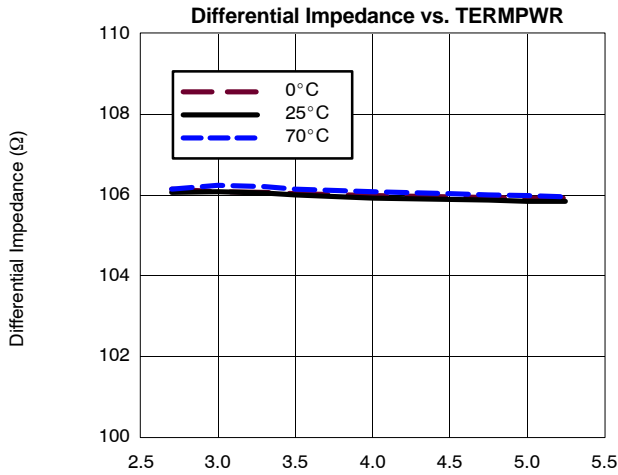



SE TYPICAL CHARACTERISTICS

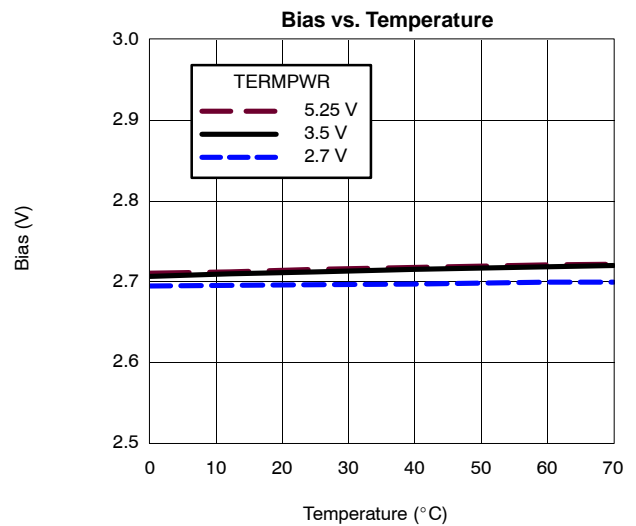
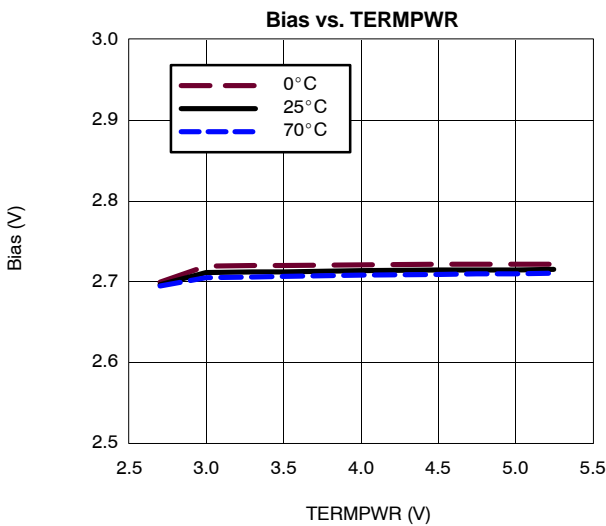
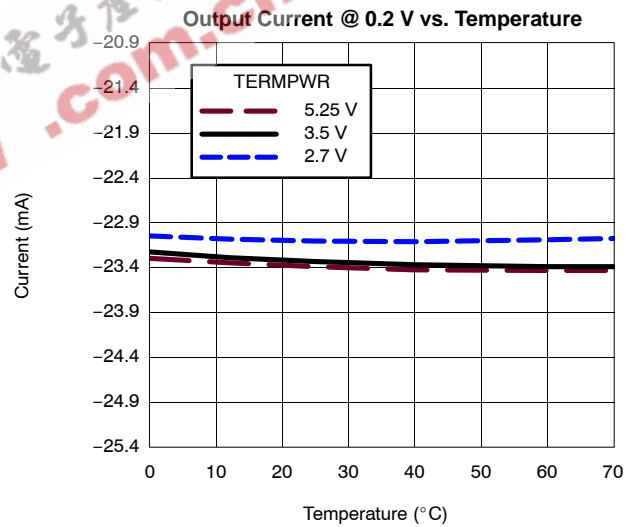
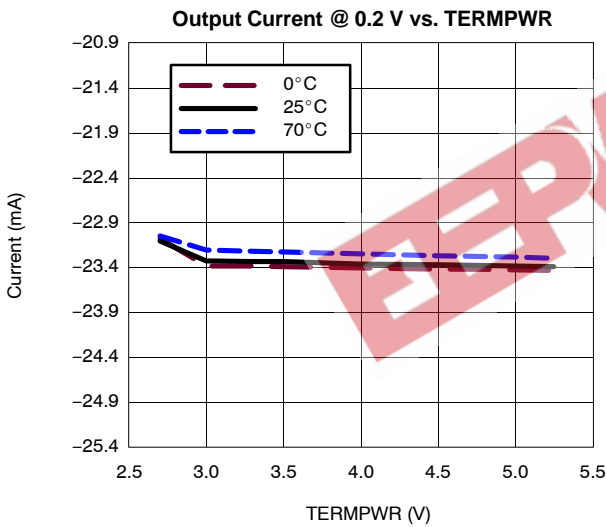
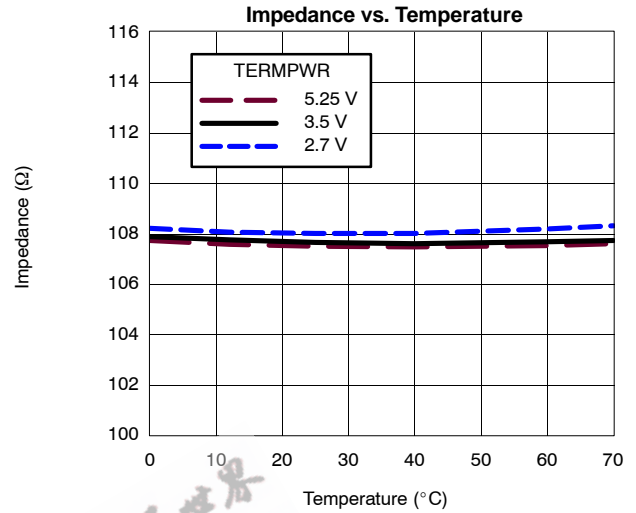
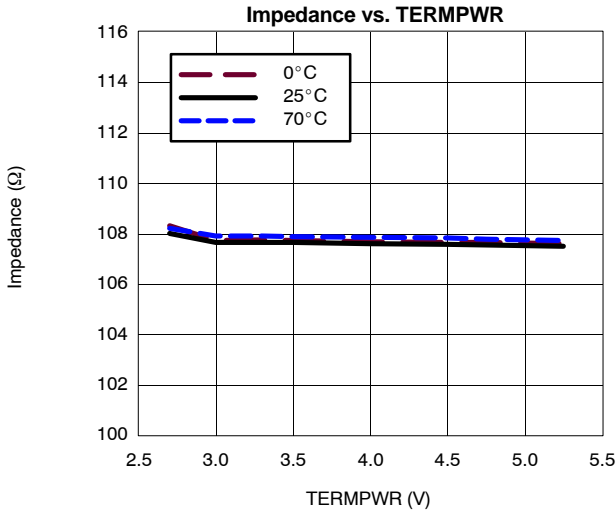



DETAILED OPERATION

The SiP5630 is a multimode active terminator IC, which detects the operating mode of the SCSI bus, and switches to the appropriate termination configuration accordingly.

Three SiP5630 terminators are required at each end of a wide SCSI bus to terminate 27 lines (18 data, 9 control). In LVD mode the SiP5630 provides 105- Ω differential impedance and 112-mV differential bias between each T⁻/T⁺ pair of terminator lines. In S/E mode the SiP5630 provides 108 Ω - impedance and 2.7-V pull-up on each T⁻ pin, and low impedance to ground on each T⁺ pin. In HPD mode the SiP5630 disconnects from the bus and presents high impedance to all T⁻/T⁺ lines.

Each SiP5630 IC has a 1.3-V DIFFSENS Regulator output that can be used to drive the DIFFSENS line of a SCSI bus. Since only one DIFFSENS regulator is required at each end of the SCSI bus each SiP5630 includes a MASTER/SLAVE pin to enable or disable its DIFFSENS regulator. The DIFFSENS regulator attempts to drive the DIFFSENS control signal to 1.3 V, but is current limited so that S/E or HPD devices on the SCSI bus can override the DIFFSENS regulator and put the bus into S/E or HPD mode of operation.

The MODE pin senses the operational state of the SCSI bus by detecting the voltage on the DIFFSENS control line through

an external R/C low pass filter. 50 k Ω /4.7 μ F are recommended component values for the filter to meet SPI-3 mode change requirements.

Three status lines (S/E, LVD, and HPD) are provided by the SiP5630. One and only one status line is asserted high when its corresponding mode has been detected; the other two status lines are driven low. The mode detection function continues to work even when the SiP5630 is in disconnect mode.

The DISABLE pin is used to connect/disconnect the SiP5630. If it is pulled to GROUND the SiP5630 is in connect mode, and operates as a terminator. If it is pulled to TERMPWR or left open the device is in disconnect mode and presents high impedance to the SCSI bus. In disconnect mode the DIFFSENS regulator is disabled but the mode detection circuitry continues to function and the status lines continue to indicate which mode is detected.

The SiP5630 operates within SCSI specifications with the TERMPWR voltage between 2.7 V and 5.25 V, which enables it to operate in both 5-V and 3.3-V systems. The 2.7-V lower limit guarantees correct performance in a 3.3-V system.