

74VHC541 Octal Buffer/Line Driver with TRI-STATE® Outputs

General Description

The VHC541 is an advanced high-speed CMOS device fabricated with silicon gate CMOS technology. It achieves the high-speed operation similar to equivalent Bipolar Schottky TTL while maintaining the CMOS low power dissipation.

The VHC541 is an octal buffer/line driver designed to be employed as memory and address drivers, clock drivers and bus oriented transmitter/receivers.

This device is similar in function to the VHC244 while providing flow-through architecture (inputs on opposite side from outputs). This pinout arrangement makes this device especially useful as an output port for microprocessors, allowing ease of layout and greater PC board density.

An input protection circuit insures that 0V to 7V can be applied to the input pins without regard to the supply voltage. This device can be used to interface 5V to 3V systems and two supply systems such as battery backup. This circuit prevents device destruction due to mismatched supply and input voltages.

Features

- Low power dissipation:
 $I_{CC} = 4 \mu A$ (max) at $T_A = 25^\circ C$
- High noise immunity: $V_{NIH} = V_{NIL} = 28\% V_{CC}$ (min)
- All inputs are equipped with a power down protection function
- Balanced propagation delays: $t_{PLH} \cong t_{PHL}$
- Low noise: $V_{OLP} = 0.9V$ (typ)
- Pin and function compatible with 74HC541

Commercial	Package Number	Package Description
74VHC541M	M20B	20-Lead Molded JEDEC SOIC
74VHC541SJ	M20D	20-Lead Molded EIAJ SOIC
74VHC541MTC	MTC20	20-Lead Molded JEDEC Type 1 TSSOP
74VHC541N	N20A	20-Lead Molded DIP

Note: Surface mount packages are also available on Tape and Reel. Specify by appending the suffix letter "X" to the ordering code.

Logic Symbol

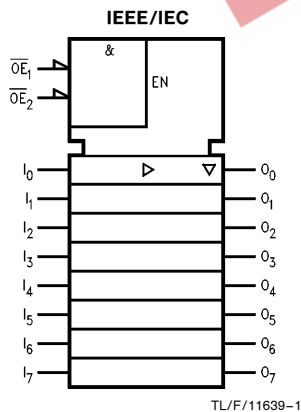

Connection Diagram

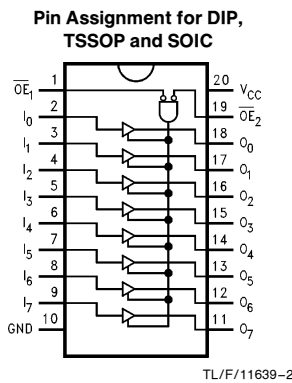

Truth Table

Inputs			Outputs
\overline{OE}_1	\overline{OE}_2	I	
L	L	H	H
H	X	X	Z
X	H	X	Z
L	L	L	L

H = HIGH Voltage Level
L = LOW Voltage Level
X = Immaterial
Z = High Impedance

TRI-STATE® is a registered trademark of National Semiconductor Corporation.

Absolute Maximum Ratings (Note 1)

Supply Voltage (V_{CC})	-0.5V to +7.0V
DC Input Voltage (V_{IN})	-0.5V to +7.0V
DC Output Voltage (V_{OUT})	-0.5V to $V_{CC} + 0.5V$
Input Diode Current (I_{IK})	-20 mA
Output Diode Current (I_{OK})	±20 mA
DC Output Current (I_{OUT})	±25 mA
DC V_{CC} /GND Current (I_{CC})	±75 mA
Storage Temperature (T_{STG})	-65°C to +150°C
Lead Temperature (T_L) (Soldering, 10 seconds)	260°C

Note 1: *Absolute Maximum Ratings are values beyond which the device may be damaged or have its useful life impaired. The databook specifications should be met, without exception, to ensure that the system design is reliable over its power supply, temperature, and output/input loading variables. National does not recommend operation outside databook specifications.*

Recommended Operating Conditions

Supply Voltage (V_{CC})	2.0V to +5.5V
Input Voltage (V_{IN})	0V to +5.5V
Output Voltage (V_{OUT})	0V to V_{CC}
Operating Temperature (T_{OPR})	-40°C to +85°C
Input Rise and Fall Time (t_r, t_f)	0 ~ 100 ns/V
	$V_{CC} = 3.3V \pm 0.3V$
	0 ~ 20 ns/V
	$V_{CC} = 5.0V \pm 0.5V$

DC Characteristics for 'VHC Family Devices

Symbol	Parameter	V_{CC} (V)	74VHC				Units	Conditions	
			$T_A = 25^\circ C$			$T_A = -40^\circ C$ to $+85^\circ C$			
			Min	Typ	Max	Min			Max
V_{IH}	High Level Input Voltage	2.0 3.0-5.5	1.50 0.7 V_{CC}			1.50 0.7 V_{CC}	V		
V_{IL}	Low Level Input Voltage	2.0 3.0-5.5		0.50 0.3 V_{CC}		0.50 0.3 V_{CC}	V		
V_{OH}	High Level Output Voltage	2.0	1.9	2.0		1.9	V	$V_{IN} = V_{IH}$ or V_{IL}	$I_{OH} = -50 \mu A$
		3.0	2.9	3.0		2.9			
		4.5	4.4	4.5		4.4	V		$I_{OH} = -4 mA$ $I_{OH} = -8 mA$
		3.0	2.58			2.48			
		4.5	3.94			3.80	V		
V_{OL}	Low Level Output Voltage	2.0		0.0	0.1		V	$V_{IN} = V_{IH}$ or V_{IL}	$I_{OL} = 50 \mu A$
		3.0		0.0	0.1				
		4.5		0.0	0.1		V		$I_{OL} = 4 mA$ $I_{OL} = 8 mA$
		3.0			0.36				
		4.5			0.36				0.44
I_{OZ}	TRI-STATE Output Off-State Current	5.5		±0.25		±2.5	μA	$V_{IN} = V_{IH}$ or V_{IL} $V_{OUT} = V_{CC}$ or GND	
I_{IN}	Input Leakage Current	0-5.5		±0.1		±1.0	μA	$V_{IN} = 5.5V$ or GND	
I_{CC}	Quiescent Supply Current	5.5		4.0		40.0	μA	$V_{IN} = V_{CC}$ or GND	

DC Characteristics for 'VHC Family Devices

Symbol	Parameter	V _{CC} (V)	74VHC		Units	Conditions
			T _A = 25°C			
			Typ	Limits		
V _{OLP} **	Quiet Output Maximum Dynamic V _{OL}	5.0	0.9	1.2	V	C _L = 50 pF
V _{OLV} **	Quiet Output Minimum Dynamic V _{OL}	5.0	-0.8	-1.0	V	C _L = 50 pF
V _{IHD} **	Minimum High Level Dynamic Input Voltage	5.0		3.5	V	C _L = 50 pF
V _{ILD} **	Maximum High Level Dynamic Input Voltage	5.0		1.5	V	C _L = 50 pF

**Parameter guaranteed by design.

EEPW 电子产品世界
.com.cn

AC Electrical Characteristics for 'VHC Family Devices:

Symbol	Parameter	V _{CC} (V)	74VHC		74VHC		Units	Conditions		
			T _A = 25°C			T _A = -40°C to +85°C				
			Min	Typ	Max	Min				Max
t _{PLH} , t _{PHL}	Propagation Delay Time	3.3 ± 0.3	5.0	7.0	1.0	8.5	ns	C _L = 15 pF C _L = 50 pF		
			7.5	10.5	1.0	12.0				
		5.0 ± 0.5	3.5	5.0	1.0	6.0	ns			
			5.0	7.0	1.0	8.0				
t _{PZL} , t _{PZH}	TRI-STATE Output Enable Time	3.3 ± 0.3	6.8	10.5	1.0	12.5	ns	R _L = 1 kΩ C _L = 15 pF C _L = 50 pF		
			9.3	14.0	1.0	16.0				
		5.0 ± 0.5	4.7	7.2	1.0	8.5	ns			
			6.2	9.2	1.0	10.5				
t _{PLZ} , t _{PHZ}	TRI-STATE Output Disable Time	3.3 ± 0.3	11.2	15.4	1.0	17.5	ns	R _L = 1 kΩ C _L = 50 pF		
		5.0 ± 0.5	6.0	8.8	1.0	10.0				
t _{OSLH} , t _{OSSL}	Output to Output Skew	3.3 ± 0.3	1.5		1.5		ns	(Note 1) C _L = 50 pF		
		5.0 ± 0.5	1.0		1.0					
C _{IN}	Input Capacitance		4	10	10		pF	V _{CC} = Open		
C _{OUT}	Output Capacitance		6				pF	V _{CC} = 5.0V		
C _{PD}	Power Dissipation Capacitance		18				pF	(Note 2)		

Note 1: Parameter guaranteed by design. t_{OSLH} = |t_{PLHmax} - t_{PLHmin}|; t_{OSSL} = |t_{PHLmax} - t_{PHLmin}|.

Note 2: C_{PD} is defined as the value of the internal equivalent capacitance which is calculated from the operating current consumption without load. Average operating current can be obtained by the equation: I_{CC} (OPR.) = C_{PD} * V_{CC} * f_{IN} + I_{CC}/8 (per bit).

Ordering Information

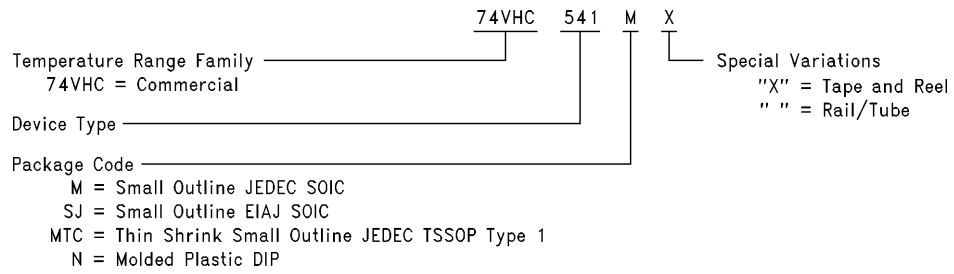

TL/F/11639-3

EEPW 电子产品世界
.com.cn

Physical Dimensions inches (millimeters)

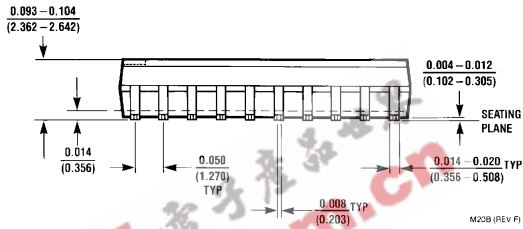
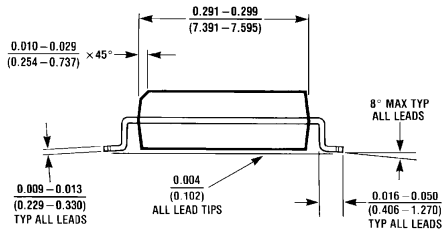
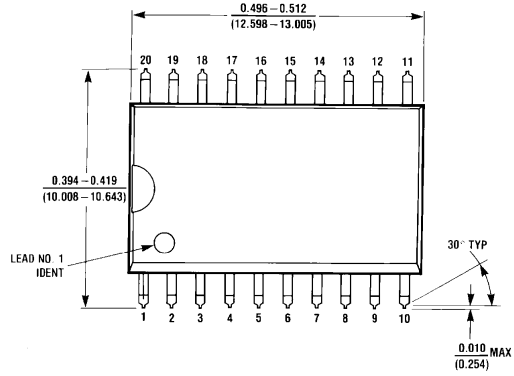

20-Lead Small Outline Integrated Circuit—JEDEC SOIC (M)
NS Package Number M20B

M20B (REV F)

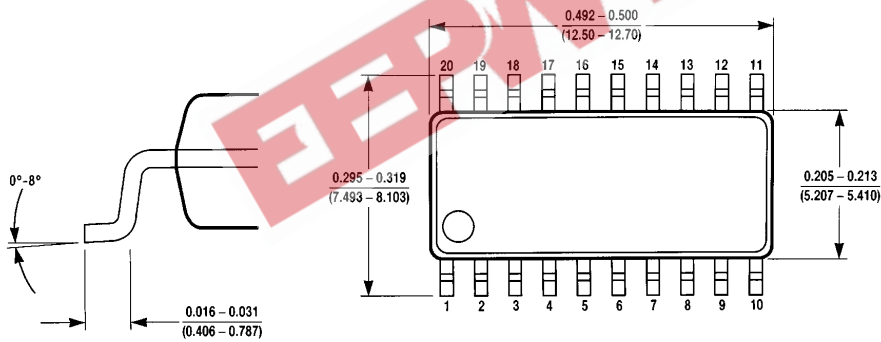

DETAIL F

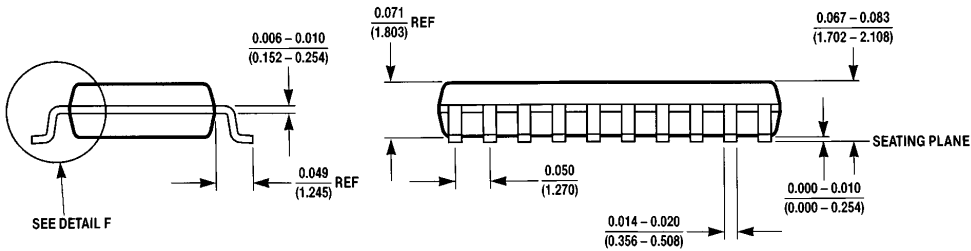

SEE DETAIL F

20-Lead Plastic EIAJ SOIC (SJ)
NS Package Number M20D

M20D (REV A)

Physical Dimensions inches (millimeters) (Continued)

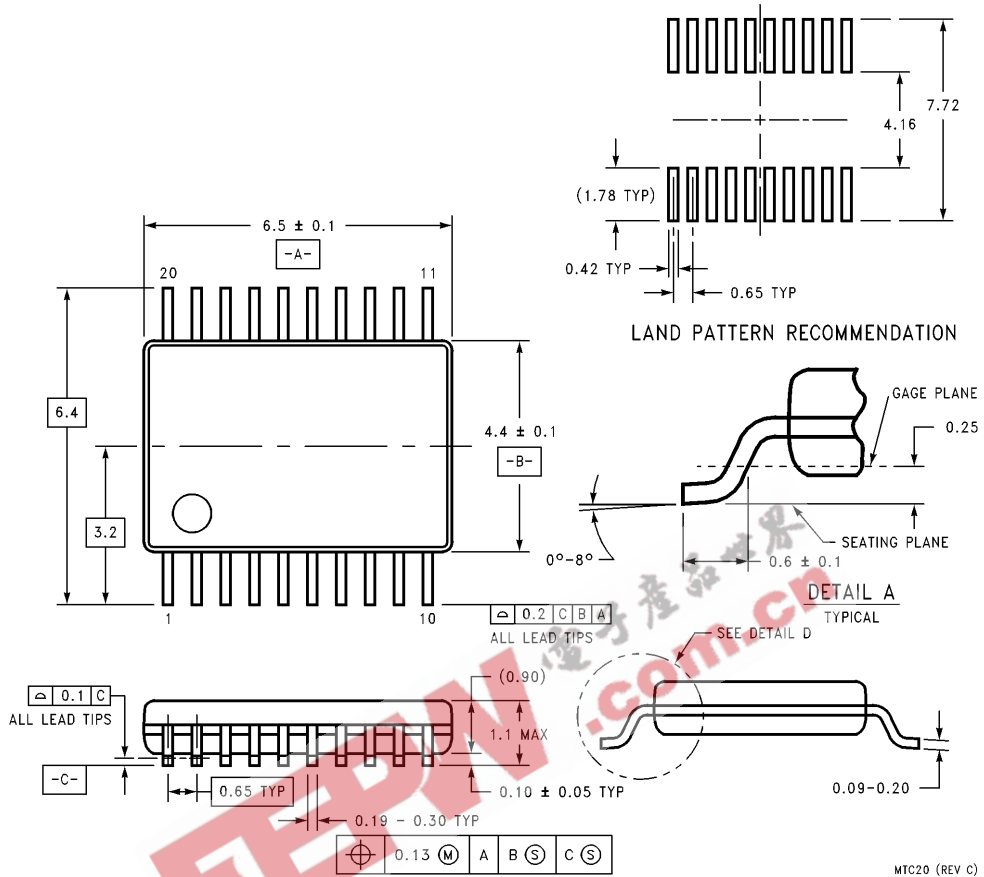

20-Lead Molded Thin Shrink Small Outline JEDEC Type 1 TSSOP
Order Number 74VHC541MTC
NS Package Number MTC20

Physical Dimensions millimeters (Continued)

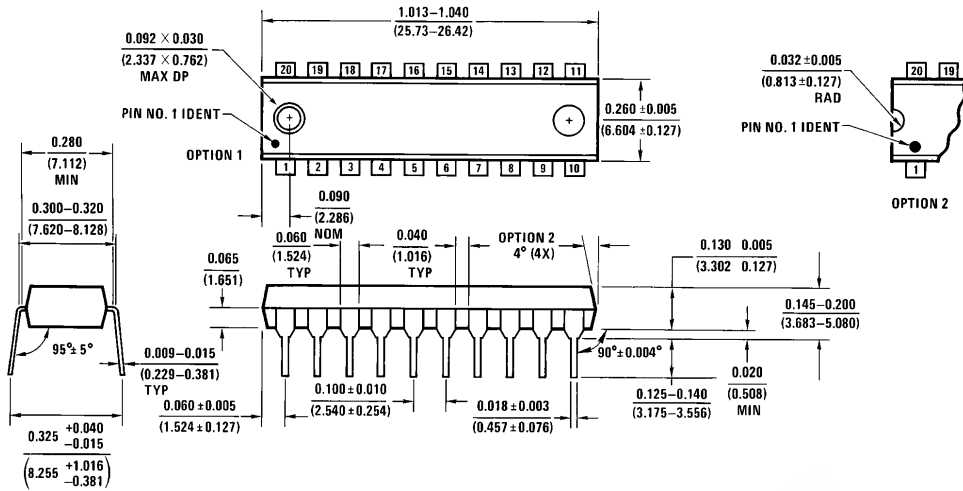

20-Lead (0.300" Wide) Molded Dual-In-Line Package
 Order Number 74VHC541N
 NS Package Number N20A



LIFE SUPPORT POLICY

NATIONAL'S PRODUCTS ARE NOT AUTHORIZED FOR USE AS CRITICAL COMPONENTS IN LIFE SUPPORT DEVICES OR SYSTEMS WITHOUT THE EXPRESS WRITTEN APPROVAL OF THE PRESIDENT OF NATIONAL SEMICONDUCTOR CORPORATION. As used herein:

1. Life support devices or systems are devices or systems which, (a) are intended for surgical implant into the body, or (b) support or sustain life, and whose failure to perform, when properly used in accordance with instructions for use provided in the labeling, can be reasonably expected to result in a significant injury to the user.
2. A critical component is any component of a life support device or system whose failure to perform can be reasonably expected to cause the failure of the life support device or system, or to affect its safety or effectiveness.



National Semiconductor Corporation
 1111 West Bardin Road
 Arlington, TX 76017
 Tel: 1(800) 272-9959
 Fax: 1(800) 737-7018

National Semiconductor Europe
 Fax: (+49) 0-180-530 85 86
 Email: cnjwge@levm2.nsc.com
 Deutsch Tel: (+49) 0-180-530 85 85
 English Tel: (+49) 0-180-532 78 32
 Français Tel: (+49) 0-180-532 93 58
 Italiano Tel: (+49) 0-180-534 16 80

National Semiconductor Hong Kong Ltd.
 13th Floor, Straight Block,
 Ocean Centre, 5 Canton Rd.
 Tsimshatsui, Kowloon
 Hong Kong
 Tel: (852) 2737-1600
 Fax: (852) 2736-9960

National Semiconductor Japan Ltd.
 Tel: 81-043-299-2309
 Fax: 81-043-299-2408

National does not assume any responsibility for use of any circuitry described, no circuit patent licenses are implied and National reserves the right at any time without notice to change said circuitry and specifications.