

# DATA SHEET

EEPW 电子产品世界  
.com.cn

**74ABT16273**  
**74ABTH16273**  
16-bit D-type flip-flop

Product specification  
Supersedes data of 1995 Sep 28  
IC23 Data Handbook

1998 Feb 27

# 16-bit D-type flip-flop

## 74ABT16273 74ABTH16273

### FEATURES

- 16-bit D-type edge triggered flip-flops
- Output capability: +64mA/-32mA
- TTL input and output switching levels
- Live insertion/extraction permitted
- Power-up reset
- 74ABTH16273 incorporates bus-hold data inputs which eliminate the need for external pull-up resistors to hold unused inputs
- Latch-up protection exceeds 500mA per JEDEC Std 17
- ESD protection exceeds 2000V per MIL STD 883 Method 3015 and 200V per Machine Model

### DESCRIPTION

The 74ABT16273 high-performance BiCMOS device combines low static and dynamic power dissipation with high speed and high output drive.

This part is a 16-bit edge triggered D-type flip-flop with non-inverting high drive outputs. This device can be used as two 8-bit flip-flops or one 16-bit flip-flop. When the clock (CP) goes High, the data on the D inputs is stored and the Q outputs display the stored data.

This device also features a master reset ( $\overline{MR}$ ) that resets all flip-flops to the Low state when  $\overline{MR}$  is set to the Low state.

Two options are available, 74ABT16273 which does not have the bus-hold feature and 74ABTH16273 which incorporates the bus-hold feature.

### QUICK REFERENCE DATA

SYMBOL	PARAMETER	CONDITIONS $T_{amb} = 25^{\circ}\text{C}; \text{GND} = 0\text{V}$	TYPICAL	UNIT
$t_{PLH}$ $t_{PHL}$	Propagation delay An to Bn or Bn to An	$C_L = 50\text{pF};$ $V_{CC} = 5.0\text{V}$	2.5 2.0	ns
$C_{IN}$	Input capacitance	$V_I = 0\text{V}$ or $V_{CC}$	4	pF
$I_{CCH}$	Quiescent supply current	Outputs High; $V_{CC} = 5.5\text{V}$	200	$\mu\text{A}$
$I_{CCL}$		Outputs low; $V_{CC} = 5.5\text{V}$	8	mA

### ORDERING INFORMATION

PACKAGES	TEMPERATURE RANGE	OUTSIDE NORTH AMERICA	NORTH AMERICA	DWG NUMBER
48-Pin Plastic SSOP Type III	-40°C to +85°C	74ABT16273 DL	BT16273 DL	SOT370-1
48-Pin Plastic TSSOP Type II	-40°C to +85°C	74ABT16273 DGG	BT16273 DGG	SOT362-1
48-Pin Plastic SSOP Type III	-40°C to +85°C	74ABTH16273 DL	BH16273 DL	SOT370-1
48-Pin Plastic TSSOP Type II	-40°C to +85°C	74ABTH16273 DGG	BH16273 DGG	SOT362-1

### LOGIC SYMBOL

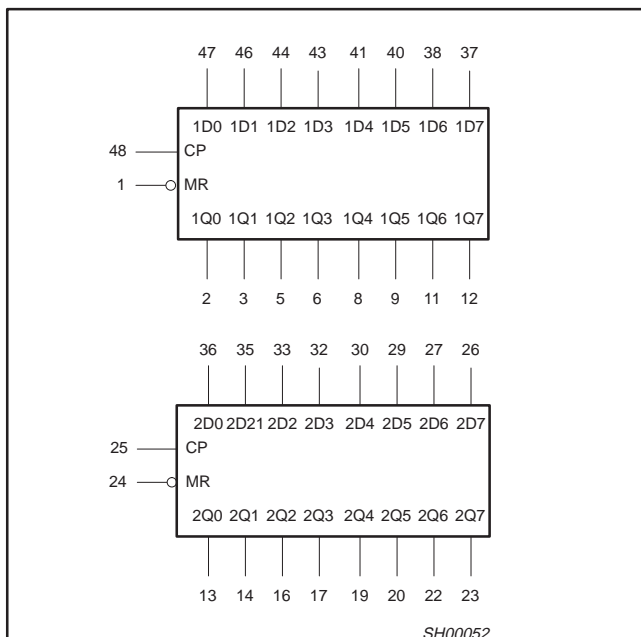

### PIN DESCRIPTION

PIN NUMBER	SYMBOL	NAME AND FUNCTION
1, 24	1MR, 2MR	Master reset input (active-Low)
2, 3, 5, 6, 8, 9, 11, 12, 13, 14, 16, 17, 19, 20, 22, 23	1Q0-1Q7 2Q0-2Q7	Data outputs
47, 46, 44, 43, 41, 40, 38, 37, 36, 35, 33, 32, 30, 29, 27, 26	1D0-1D7 2D0-2D7	Data inputs
25, 48	1CP, 2CP	Clock pulse input (active rising edge)
4, 10, 15, 21, 28, 34, 39, 45	GND	Ground (0V)
7, 18, 31, 42	$V_{CC}$	Positive supply voltage

# 16-bit D-type flip-flop

74ABT16273  
74ABTH16273

## LOGIC SYMBOL (IEEE/IEC)

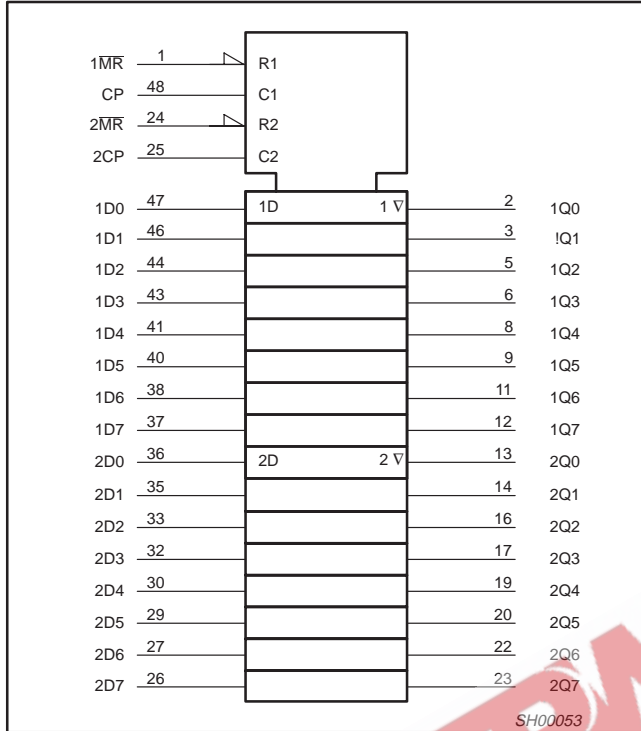

## PIN CONFIGURATION

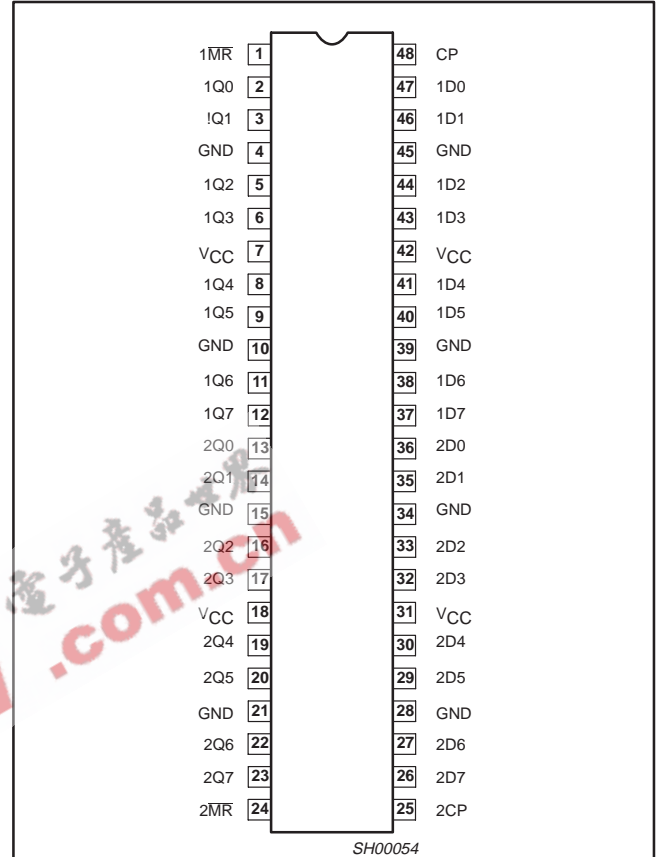

## FUNCTION TABLE

Inputs			Output	operating mode
nMR	nCP	nDX	nQ0-nQ7	
L	X	X	L	Reset (clear)
H	↑	h	H	Load "1"
H	↑	l	L	Load "0"
H	L	X	Q <sub>0</sub>	Retain state

H = High voltage level  
h = high voltage level one set-up time prior to the Low-to-High clock transition  
L = Low voltage level  
l = Low voltage level one set-up time prior to the Low-to-High clock transition  
X = Don't care  
↑ = Low-to-High clock transition  
Q<sub>0</sub> = Output as it was

## 16-bit D-type flip-flop

74ABT16273  
74ABTH16273

## LOGIC DIAGRAM

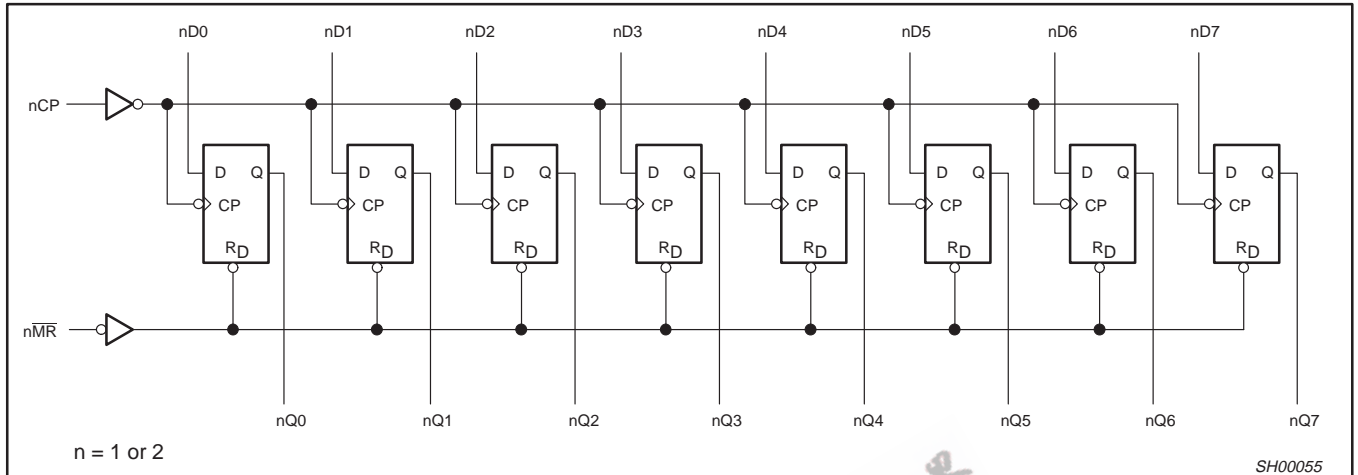
ABSOLUTE MAXIMUM RATINGS<sup>1, 2</sup>

SYMBOL	PARAMETER	CONDITIONS	RATING	UNIT
$V_{CC}$	DC supply voltage		-0.5 to -7.0	V
$I_{IK}$	DC input diode current	$V_I < 0$	-18	mA
$V_I$	DC input voltage <sup>3</sup>		-1.2 to +7.0	V
$I_{OK}$	DC output diode current	$V_O < 0$	-50	mA
$V_{OUT}$	DC output voltage <sup>3</sup>	Output in Off or High state	-0.5 to +5.5	V
$I_{OUT}$	DC output current	Output in Low state	128	mA
		Output in High state	-64	
$T_{stg}$	Storage temperature range		-65 to +150	°C

## NOTES:

- Stresses beyond those listed may cause permanent damage to the device. These are stress ratings only and functional operation of the device at these or any other conditions beyond those indicated under "recommended operating conditions" is not implied. Exposure to absolute-maximum-rated conditions for extended periods may affect device reliability.
- The performance capability of a high-performance integrated circuit in conjunction with its thermal environment can create junction temperatures which are detrimental to reliability. The maximum junction temperature of this integrated circuit should not exceed 150°C.
- The input and output negative voltage ratings may be exceeded if the input and output clamp current ratings are observed.

## RECOMMENDED OPERATING CONDITIONS

SYMBOL	PARAMETER	LIMITS		UNIT
		MIN	MAX	
$V_{CC}$	DC supply voltage	4.5	5.5	V
$V_I$	Input voltage	0	$V_{CC}$	V
$V_{IH}$	High-level input voltage	2.0		V
$V_{IL}$	Input voltage		0.8	V
$I_{OH}$	High-level output current		-32	mA
$I_{OL}$	Low-level output current		64	mA
$\Delta t/\Delta v$	Input transition rise or fall rate; Outputs enabled	0	10	ns/V
$T_{amb}$	Operating free-air temperature range	-40	+85	°C

## 16-bit D-type flip-flop

74ABT16273  
74ABTH16273

## DC ELECTRICAL CHARACTERISTICS

SYMBOL	PARAMETER	TEST CONDITIONS	LIMITS					UNIT
			Temp = +25°C			Temp = -40°C to +85°C		
			MIN	TYP	MAX	MIN	MAX	
$V_{IK}$	Input clamp voltage	$V_{CC} = 4.5V; I_{IK} = -18mA$		0.9	-1.2		-1.2	V
$V_{OH}$	High-level output voltage	$V_{CC} = 4.5V; I_{OH} = -3mA; V_I = V_{IL} \text{ or } V_{IH}$	2.5	2.9		2.5		V
		$V_{CC} = 5.0V; I_{OH} = -3mA; V_I = V_{IL} \text{ or } V_{IH}$	3.0	3.4		3.0		
		$V_{CC} = 4.5V; I_{OH} = -32mA; V_I = V_{IL} \text{ or } V_{IH}$	2.0	2.4		2.0		
$V_{OL}$	Low-level output voltage	$V_{CC} = 4.5V; I_{OL} = 64mA; V_I = V_{IL} \text{ or } V_{IH}$		0.42	0.55		0.55	
$V_{RST}$	Power-up output voltage <sup>3</sup>	$V_{CC} = 5.5V; I_O = 1mA; V_I = GND \text{ or } V_{CC}$		0.13	0.55		0.55	V
$I_I$	Input leakage current 74ABT16273	$V_{CC} = 5.5V; V_I = V_{CC} \text{ or } GND$		±0.1	±1		±1	µA
$I_I$	Input leakage current 74ABTH16273	$V_{CC} = 5.5V; V_I = V_{CC} \text{ or } GND$		±0.01	±1		±1	µA
		$V_{CC} = 5.5V; V_I = V_{CC}$		0.01	1		1	µA
		$V_{CC} = 5.5V; V_I = 0$		-2	-3		-5	µA
$I_{HOLD}$	Bus Hold current inputs <sup>4</sup> 74ABTH16273	$V_{CC} = 4.5V; V_I = 0.8V$	35			35		µA
		$V_{CC} = 4.5V; V_I = 2.0V$	-75			-75		
		$V_{CC} = 5.5V; V_I = 0 \text{ to } 5.5V$	±800					
$I_{OFF}$	Power-off leakage current	$V_{CC} = 0.0V; V_O \text{ or } V_I < 4.5V$		±5.0	±100		±100	µA
$I_O$	output current <sup>1</sup>	$V_{CC} = 5.5V; V_O = 2.5V$	-50	-70	-180	-50	-180	mA
$I_{CEX}$	Output High leakage current	$V_{CC} = 5.5V; V_O = 5.5V; V_I = GND \text{ or } V_{CC}$		5.0	50		50	µA
$I_{CCH}$	Quiescent supply current	$V_{CC} = 5.5V; \text{Outputs High, } V_I = GND \text{ or } V_{CC}$		0.2	1		1	mA
$I_{CCL}$		$V_{CC} = 5.5V; \text{Outputs Low, } V_I = GND \text{ or } V_{CC}$		8	19		19	
$\Delta I_{CC}$	Additional supply current per input pin <sup>2</sup> 74ABT16273	$V_{CC} = 5.5V; \text{One input at } 3.4V. \text{ Other inputs at } V_{CC} \text{ or } GND$		5	100		100	µA
$\Delta I_{CC}$	Additional supply current per input pin <sup>2</sup> 74ABTH16273	$V_{CC} = 5.5V; \text{One input at } 3.4V. \text{ Other inputs at } V_{CC} \text{ or } GND$		0.2	1		1	mA

## NOTES:

- Not more than one output should be tested at a time, and the duration of the test should not exceed one second.
- This is the increase in supply current for each input at 3.4V.
- For valid test results, data must not be loaded into the flip-flops (or latches) after applying the power.
- This is the bus hold overdrive current required to force the input to the opposite logic state.

## AC CHARACTERISTICS

GND = 0V;  $t_R = t_F = 2.5ns$ ;  $C_L = 50pF$ ;  $R_L = 500\Omega$ ;

SYMBOL	PARAMETER	WAVEFORM	LIMITS					UNIT
			$T_{amb} = +25^\circ C$ $V_{CC} = +5.0V$			$T_{amb} = -40 \text{ to } +85^\circ C$ $V_{CC} = +5.0V \pm 0.5V$		
			MIN	TYP	MAX	MIN	MAX	
$t_{PLH}$ $t_{PHL}$	Propagation delay nCP to nQx	1	1.5 1.2	2.5 2.0	3.4 2.7	1.5 1.2	4.0 3.0	ns
$t_{PHL}$	Propagation delay nMR to nQx	2	1.9	3.7	4.3	1.9	5.3	ns
$f_{MAX}$	Maximum clock frequency	1	150	240		150		MHz

# 16-bit D-type flip-flop

74ABT16273  
74ABTH16273

## AC SETUP REQUIREMENTS

GND = 0V;  $t_R = t_F = 2.5\text{ns}$ ;  $C_L = 50\text{pF}$ ;  $R_L = 500\Omega$

SYMBOL	PARAMETER	WAVEFORM	LIMITS			UNIT
			$T_{\text{amb}} = +25^\circ\text{C}$ $V_{\text{CC}} = +5.0\text{V}$		$T_{\text{amb}} = -40 \text{ to } +85^\circ\text{C}$ $V_{\text{CC}} = +5.0\text{V} \pm 0.5\text{V}$	
			MIN	TYP	MIN	
$t_{\text{S}}(\text{H})$ $t_{\text{S}}(\text{L})$	Setup time, High or Low nDx to nCP	3	2.0 2.0	1.0 1.0	2.0 2.0	ns
$t_{\text{H}}(\text{H})$ $t_{\text{H}}(\text{L})$	Hold time, High or Low nDx to nCP	3	0 0	-0.6 -0.6	0 0	ns
$t_{\text{W}}(\text{H})$ $t_{\text{W}}(\text{L})$	Clock pulse width High or Low	1	3.3 3.3	1.2 1.0	3.3 3.3	ns
$t_{\text{W}}(\text{L})$	Master Reset pulse width, Low	2	3.3	1.1	3.3	ns
$t_{\text{REC}}$	Recovery time nMR + nCP	2	2.0	0.0	2.0	ns

## AC WAVEFORMS

$V_M = 1.5\text{V}$ ,  $V_{\text{IN}} = \text{GND to } 2.7\text{V}$

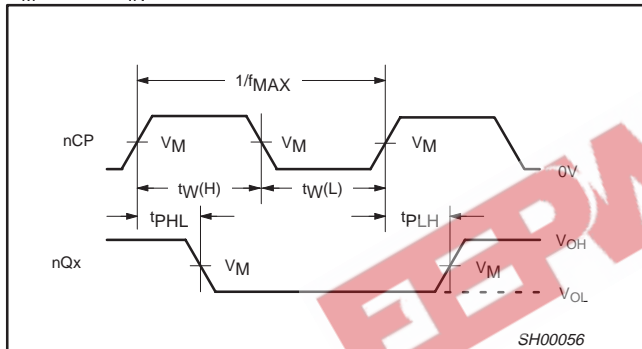

**Waveform 1. Propagation Delay, Clock Input to Output, Clock Pulse Width, and Maximum Clock Frequency**

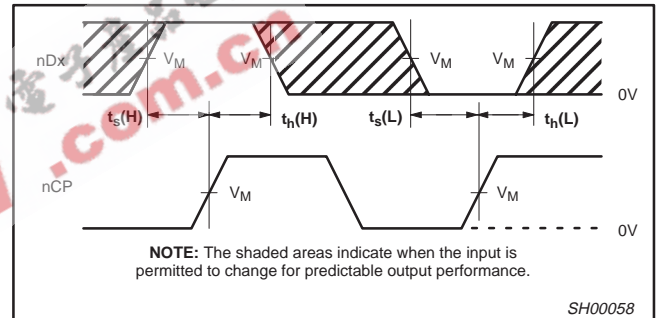

**Waveform 3. Data Setup and Hold Times**

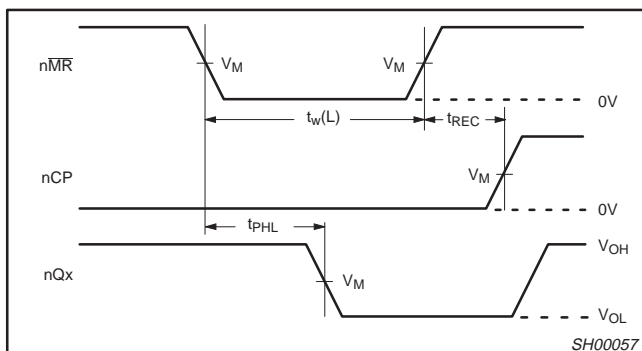

**Waveform 2. Master Reset Pulse Width, Master Reset to Output Delay and Master Reset to Clock Recovery Time**

# 16-bit D-type flip-flop

74ABT16273  
74ABTH16273

## TEST CIRCUIT AND WAVEFORM

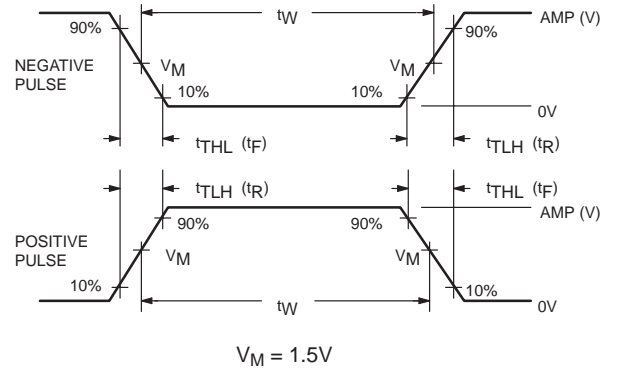
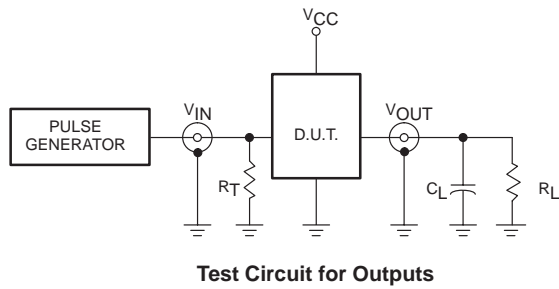

### DEFINITIONS

- $R_L$  = Load resistor; see AC CHARACTERISTICS for value.
- $C_L$  = Load capacitance includes jig and probe capacitance; see AC CHARACTERISTICS for value.
- $R_T$  = Termination resistance should be equal to  $Z_{OUT}$  of pulse generators.

FAMILY	INPUT PULSE REQUIREMENTS				
	Amplitude	Rep. Rate	$t_W$	$t_R$	$t_F$
74ABT16	3.0V	1MHz	500ns	2.5ns	2.5ns

SH00059

16-bit D-type flip-flop

74ABT16273  
74ABTH16273

SSOP48: plastic shrink small outline package; 48 leads; body width 7.5 mm

SOT370-1

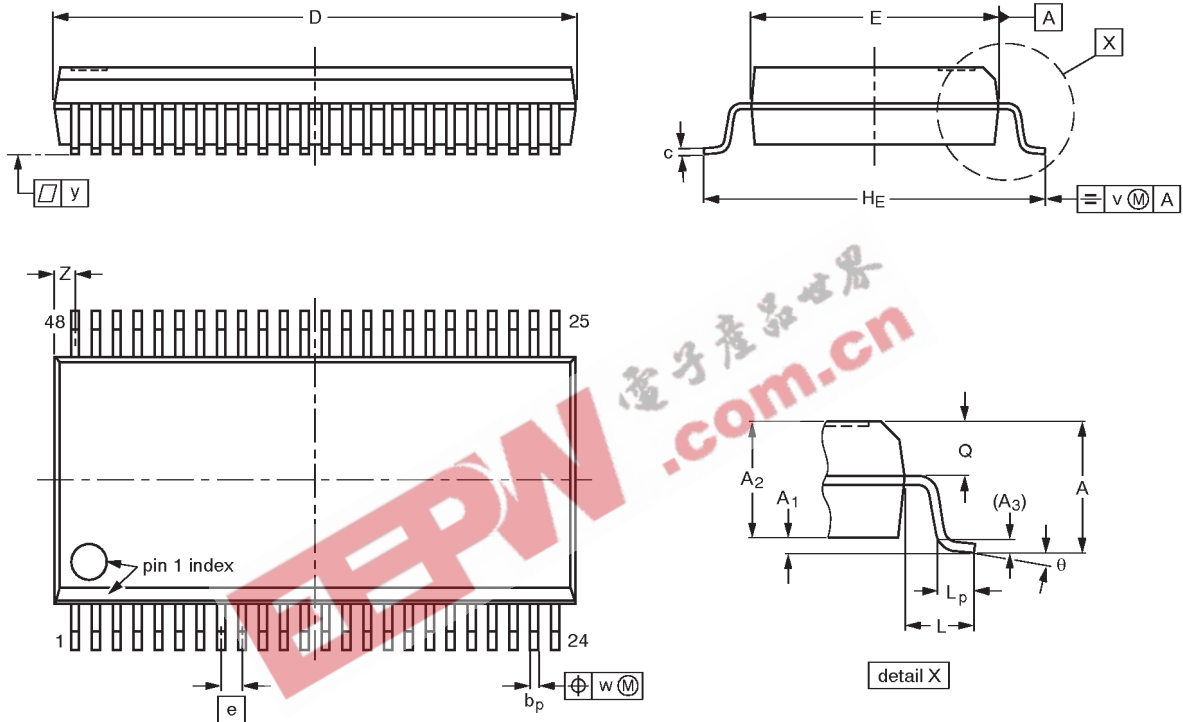

DIMENSIONS (mm are the original dimensions)

UNIT	A max.	A <sub>1</sub>	A <sub>2</sub>	A <sub>3</sub>	b <sub>p</sub>	c	D <sup>(1)</sup>	E <sup>(1)</sup>	e	H <sub>E</sub>	L	L <sub>p</sub>	Q	v	w	y	z <sup>(1)</sup>	θ
mm	2.8	0.4 0.2	2.35 2.20	0.25	0.3 0.2	0.22 0.13	16.00 15.75	7.6 7.4	0.635	10.4 10.1	1.4	1.0 0.6	1.2 1.0	0.25	0.18	0.1	0.85 0.40	8° 0°

Note

1. Plastic or metal protrusions of 0.25 mm maximum per side are not included.

OUTLINE VERSION	REFERENCES				EUROPEAN PROJECTION	ISSUE DATE
	IEC	JEDEC	EIAJ			
SOT370-1		MO-118AA				93-11-02 95-02-04



16-bit D-type flip-flop

74ABT16273  
74ABTH16273

TSSOP48: plastic thin shrink small outline package; 48 leads; body width 6.1mm

SOT362-1

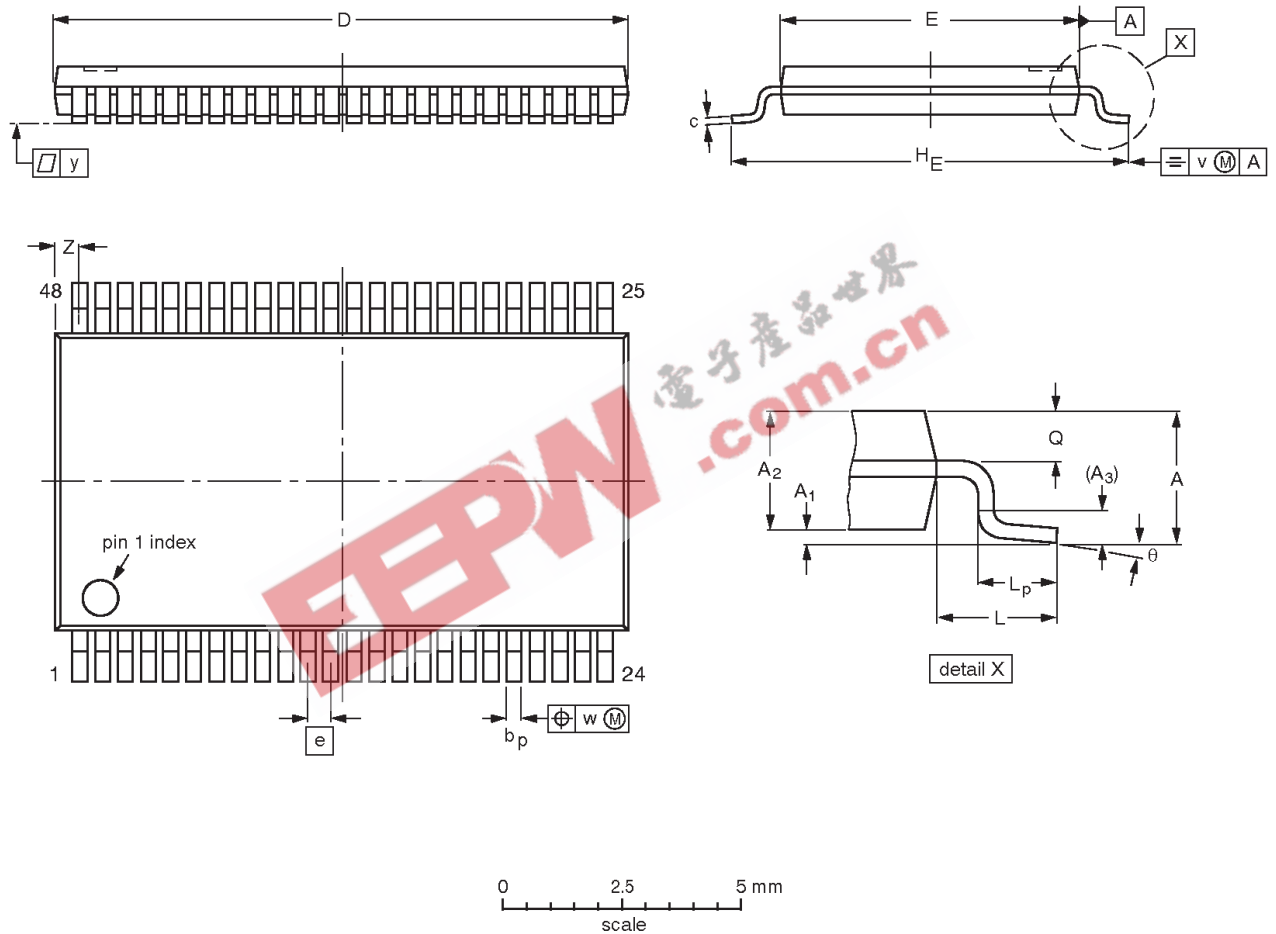

**DIMENSIONS (mm are the original dimensions).**

UNIT	A max.	A <sub>1</sub>	A <sub>2</sub>	A <sub>3</sub>	b <sub>p</sub>	c	D <sup>(1)</sup>	E <sup>(2)</sup>	e	H <sub>E</sub>	L	L <sub>p</sub>	Q	v	w	y	Z	θ
mm	1.2	0.15 0.05	1.05 0.85	0.25	0.28 0.17	0.2 0.1	12.6 12.4	6.2 6.0	0.5	8.3 7.9	1	0.8 0.4	0.50 0.35	0.25	0.08	0.1	0.8 0.4	8° 0°

**Notes**

1. Plastic or metal protrusions of 0.15 mm maximum per side are not included.
2. Plastic interlead protrusions of 0.25 mm maximum per side are not included.

OUTLINE VERSION	REFERENCES				EUROPEAN PROJECTION	ISSUE DATE
	IEC	JEDEC	EIAJ			
SOT362-1		MO-153ED				93-02-03 95-02-10

74ABT16273  
74ABTH16273

### Data sheet status

Data sheet status	Product status	Definition [1]
Objective specification	Development	This data sheet contains the design target or goal specifications for product development. Specification may change in any manner without notice.
Preliminary specification	Qualification	This data sheet contains preliminary data, and supplementary data will be published at a later date. Philips Semiconductors reserves the right to make changes at any time without notice in order to improve design and supply the best possible product.
Product specification	Production	This data sheet contains final specifications. Philips Semiconductors reserves the right to make changes at any time without notice in order to improve design and supply the best possible product.

[1] Please consult the most recently issued datasheet before initiating or completing a design.

### Definitions

**Short-form specification** — The data in a short-form specification is extracted from a full data sheet with the same type number and title. For detailed information see the relevant data sheet or data handbook.

**Limiting values definition** — Limiting values given are in accordance with the Absolute Maximum Rating System (IEC 134). Stress above one or more of the limiting values may cause permanent damage to the device. These are stress ratings only and operation of the device at these or at any other conditions above those given in the Characteristics sections of the specification is not implied. Exposure to limiting values for extended periods may affect device reliability.

**Application information** — Applications that are described herein for any of these products are for illustrative purposes only. Philips Semiconductors make no representation or warranty that such applications will be suitable for the specified use without further testing or modification.

### Disclaimers

**Life support** — These products are not designed for use in life support appliances, devices or systems where malfunction of these products can reasonably be expected to result in personal injury. Philips Semiconductors customers using or selling these products for use in such applications do so at their own risk and agree to fully indemnify Philips Semiconductors for any damages resulting from such application.

**Right to make changes** — Philips Semiconductors reserves the right to make changes, without notice, in the products, including circuits, standard cells, and/or software, described or contained herein in order to improve design and/or performance. Philips Semiconductors assumes no responsibility or liability for the use of any of these products, conveys no license or title under any patent, copyright, or mask work right to these products, and makes no representations or warranties that these products are free from patent, copyright, or mask work right infringement, unless otherwise specified.

Philips Semiconductors  
811 East Arques Avenue  
P.O. Box 3409  
Sunnyvale, California 94088-3409  
Telephone 800-234-7381

© Copyright Philips Electronics North America Corporation 1998  
All rights reserved. Printed in U.S.A.

print code

Date of release: 05-96

Document order number:

9397-750-03489

*Let's make things better.*