

## 74LVX161284A Low Voltage IEEE 161284 Translating Transceiver

### General Description

The LVX161284A contains eight bidirectional data buffers and eleven control/status buffers to implement a full IEEE 1284 compliant interface. The device supports the IEEE 1284 standard, with the exception of output slew rate, and is intended to be used in an Extended Capabilities Port mode (ECP). The pinout allows for easy connection from the Peripheral (A-side) to the Host (cable side).

Outputs on the cable side can be configured to be either open drain or high drive ( $\pm 14$  mA) and are connected to a separate power supply pin ( $V_{CC\_cable}$ ) to allow these outputs to be driven by a higher supply voltage than the A-side. The pull-up and pull-down series termination resistance of these outputs on the cable side is optimized to drive an external cable. In addition, all inputs (except HLH) and outputs on the cable side contain internal pull-up resistors connected to the  $V_{CC\_cable}$  supply to provide proper termination and pull-ups for open drain mode.

Outputs on the Peripheral side are standard low-drive CMOS outputs designed to interface with 3V logic. The DIR input controls data flow on the  $A_1$ - $A_8/B_1$ - $B_8$  transceiver pins.

### Features

- Supports IEEE 1284 Level 1 and Level 2 signaling standards for bidirectional parallel communications between personal computers and printing peripherals with the exception of output slew rate
- Translation capability allows outputs on the cable side to interface with 5V signals
- All inputs have hysteresis to provide noise margin
- B and Y output resistance optimized to drive external cable
- B and Y outputs in high impedance mode during power down
- Inputs and outputs on cable side have internal pull-up resistors
- Flow-through pin configuration allows easy interface between the "Peripheral and Host"
- Replaces the function of two (2) 74ACT1284 devices

### Ordering Code

Order Number	Package Number	Package Description
74LVX161284AMTD	MTD48	48-Lead Thin Shrink Small Outline Package (TSSOP), JEDEC MO-153, 6.1mm Wide [TUBE]
74LVX161284AMTX	MTD48	48-Lead Thin Shrink Small Outline Package (TSSOP), JEDEC MO-153, 6.1mm Wide [TAPE and REEL]

### Connection Diagram

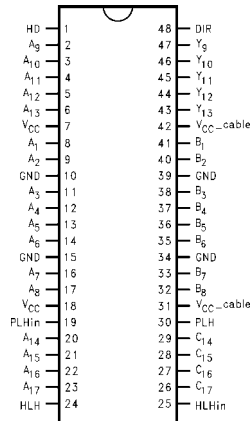

### Pin Descriptions

Pin Names	Description
HD	High Drive Enable Input (Active HIGH)
DIR	Direction Control Input
A <sub>1</sub> -A <sub>8</sub>	Inputs or Outputs
B <sub>1</sub> -B <sub>8</sub>	Inputs or Outputs
A <sub>9</sub> -A <sub>13</sub>	Inputs
Y <sub>9</sub> -Y <sub>13</sub>	Outputs
A <sub>14</sub> -A <sub>17</sub>	Outputs
C <sub>14</sub> -C <sub>17</sub>	Inputs
PLH <sub>IN</sub>	Peripheral Logic HIGH Input
PLH	Peripheral Logic HIGH Output
HLH <sub>IN</sub>	Host Logic HIGH Input
HLH	Host Logic HIGH Output

### Logic Symbol

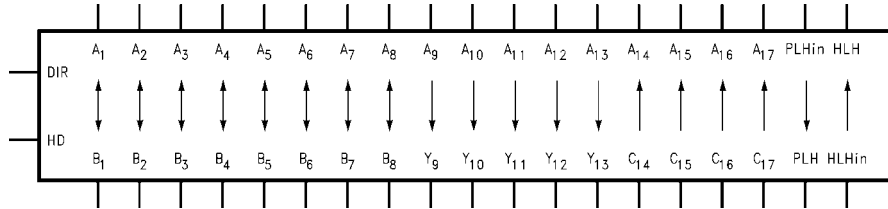

### Truth Table

Inputs		Outputs
DIR	HD	
L	L	B <sub>1</sub> -B <sub>8</sub> Data to A <sub>1</sub> -A <sub>8</sub> , and A <sub>9</sub> -A <sub>13</sub> Data to Y <sub>9</sub> -Y <sub>13</sub> (Note 1) C <sub>14</sub> -C <sub>17</sub> Data to A <sub>14</sub> -A <sub>17</sub> PLH Open Drain Mode
L	H	B <sub>1</sub> -B <sub>8</sub> Data to A <sub>1</sub> -A <sub>8</sub> , and A <sub>9</sub> -A <sub>13</sub> Data to Y <sub>9</sub> -Y <sub>13</sub> C <sub>14</sub> -C <sub>17</sub> Data to A <sub>14</sub> -A <sub>17</sub>
H	L	A <sub>1</sub> -A <sub>8</sub> Data to B <sub>1</sub> -B <sub>8</sub> (Note 2) A <sub>9</sub> -A <sub>13</sub> Data to Y <sub>9</sub> -Y <sub>13</sub> (Note 1) C <sub>14</sub> -C <sub>17</sub> Data to A <sub>14</sub> -A <sub>17</sub> PLH Open Drain Mode
H	H	A <sub>1</sub> -A <sub>8</sub> Data to B <sub>1</sub> -B <sub>8</sub> A <sub>9</sub> -A <sub>13</sub> Data to Y <sub>9</sub> -Y <sub>13</sub> C <sub>14</sub> -C <sub>17</sub> Data to A <sub>14</sub> -A <sub>17</sub>

Note 1: Y<sub>9</sub>-Y<sub>13</sub> Open Drain Outputs

Note 2: B<sub>1</sub>-B<sub>8</sub> Open Drain Outputs

### Logic Diagram

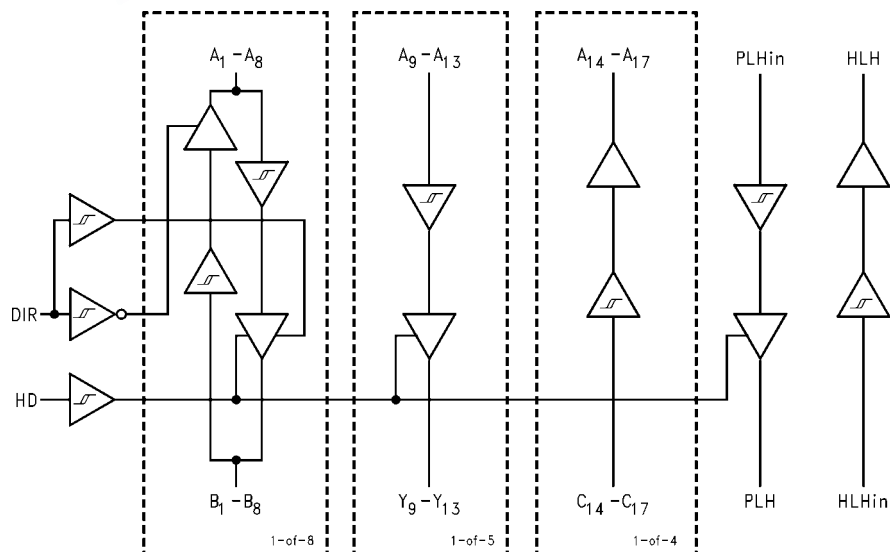

Absolute Maximum Ratings (Note 3)		Recommended Operating Conditions	
Supply Voltage		Supply Voltage	
$V_{CC}$	-0.5V to +4.6V	$V_{CC}$	3.0V to 3.6V
$V_{CC-Cable}$	-0.5V to +7.0V	$V_{CC-Cable}$	3.0V to 5.5V
$V_{CC-Cable}$ Must Be $\geq V_{CC}$		DC Input Voltage ( $V_I$ )	0V to $V_{CC}$
Input Voltage ( $V_I$ )—(Note 4)		Open Drain Voltage ( $V_O$ )	0V to 5.5V
$A_1-A_{13}, PLH_{IN}, DIR, HD$	-0.5V to $V_{CC} + 0.5V$	Operating Temperature ( $T_A$ )	-40°C to +85°C
$B_1-B_8, C_{14}-C_{17}, HLH_{IN}$	-0.5V to +5.5V (DC)		
$B_1-B_8, C_{14}-C_{17}, HLH_{IN}$	-2.0V to +7.0V*		
	*40 ns Transient		
Output Voltage ( $V_O$ )			
$A_1-A_8, A_{14}-A_{17}, HLH$	-0.5V to $V_{CC} + 0.5V$		
$B_1-B_8, Y_9-Y_{13}, PLH$	-0.5V to +5.5V (DC)		
$B_1-B_8, Y_9-Y_{13}, PLH$	-2.0V to +7.0V*		
	*40 ns Transient		
DC Output Current ( $I_O$ )			
$A_1-A_8, HLH$	$\pm 25$ mA		
$B_1-B_8, Y_9-Y_{13}$	$\pm 50$ mA		
PLH (Output LOW)	84 mA		
PLH (Output HIGH)	-50 mA		
Input Diode Current ( $I_{IK}$ )—(Note 4)			
$DIR, HD, A_9-A_{13}, PLH, HLH, C_{14}-C_{17}$	-20 mA		
Output Diode Current ( $I_{OK}$ )			
$A_1-A_8, A_{14}-A_{17}, HLH$	$\pm 50$ mA		
$B_1-B_8, Y_9-Y_{13}, PLH$	-50 mA		
DC Continuous $V_{CC}$ or Ground Current			
	$\pm 200$ mA		
Storage Temperature			
	-65°C to +150°C		
ESD (HBM) Last Passing Voltage			
	2000V		

Note 3: Absolute Maximum continuous ratings are those values beyond which damage to the device may occur. Exposure to these conditions or conditions beyond those indicated may adversely affect device reliability. Functional operation under absolute maximum rated conditions is not implied.

Note 4: Either voltage limit or current limit is sufficient to protect inputs.

## DC Electrical Characteristics

Symbol	Parameter	$V_{CC}$ (V)	$V_{CC-Cable}$ (V)	$T_A = -40^\circ\text{C to } +85^\circ\text{C}$		Units	Conditions	
				Guaranteed Limits				
$V_{IK}$	Input Clamp Diode Voltage	3.0	3.0	-1.2		V	$I_I = -18$ mA	
$V_{IH}$	Minimum HIGH Level Input Voltage	$A_n, B_n, PLH_{IN}, DIR, HD$	3.0-3.6	3.0-5.5	2.0		V	
		$C_n$	3.0-3.6	3.0-5.5	2.3			
		$HLH_{IN}$	3.0-3.6	3.0-5.5	2.6			
$V_{IL}$	Maximum LOW Level Input Voltage	$A_n, B_n, PLH_{IN}, DIR, HD$	3.0-3.6	3.0-5.5	0.8		V	
		$C_n$	3.0-3.6	3.0-5.5	0.8			
		$HLH_{IN}$	3.0-3.6	3.0-5.5	1.6			
$\Delta V_T$	Minimum Input Hysteresis	$A_n, B_n, PLH_{IN}, DIR, HD$	3.3	5.0	0.4		V	$V_T^+ - V_T^-$ $V_T^+ - V_T^-$ $V_T^+ - V_T^-$
		$C_n$	3.3	5.0	0.8			
		$HLH_{IN}$	3.3	5.0	0.2			
$V_{OH}$	Minimum HIGH Level Output Voltage	$A_n, HLH$	3.0	3.0	2.8		V	$I_{OH} = -50$ $\mu$ A $I_{OH} = -4$ mA $I_{OH} = -14$ mA $I_{OH} = -14$ mA $I_{OH} = -500$ $\mu$ A
		$B_n, Y_n$	3.0	3.0	2.4			
		$B_n, Y_n$	3.0	3.0	2.0			
		$B_n, Y_n$	3.0	4.5	2.23			
		PLH	3.15	3.15	3.1			

## DC Electrical Characteristics (Continued)

Symbol	Parameter		V <sub>CC</sub> (V)	V <sub>CC—Cable</sub> (V)	T <sub>A</sub> = -40°C to +85°C	Units	Conditions	
					Guaranteed Limits			
V <sub>OL</sub>	Maximum LOW Level Output Voltage	A <sub>n</sub> , HLH	3.0	3.0	0.2	V	I <sub>OL</sub> = 50 μA	
			3.0	3.0	0.4		I <sub>OL</sub> = 4 mA	
		B <sub>n</sub> , Y <sub>n</sub>	3.0	3.0	0.8		I <sub>OL</sub> = 14 mA	
		B <sub>n</sub> , Y <sub>n</sub>	3.0	4.5	0.77		I <sub>OL</sub> = 14 mA	
		PLH	3.0	3.0	0.95		I <sub>OL</sub> = 84 mA	
		PLH	3.0	4.5	0.9		I <sub>OL</sub> = 84 mA	
R <sub>D</sub>	Maximum Output Impedance	B <sub>1</sub> –B <sub>8</sub> , Y <sub>9</sub> –Y <sub>13</sub>	3.3	3.3	60	Ω	(Note 5)(Note 7)	
			3.3	5.0	55			
	Minimum Output Impedance	B <sub>1</sub> –B <sub>8</sub> , Y <sub>9</sub> –Y <sub>13</sub>	3.3	3.3	30		(Note 5)(Note 7)	
			3.3	5.0	35			
R <sub>P</sub>	Maximum Pull-Up Resistance	B <sub>1</sub> –B <sub>8</sub> , Y <sub>9</sub> –Y <sub>13</sub> , C <sub>14</sub> –C <sub>17</sub>	3.3	3.3	1650	Ω		
			3.3	5.0	1650			
	Minimum Pull-Up Resistance	B <sub>1</sub> –B <sub>8</sub> , Y <sub>9</sub> –Y <sub>13</sub>	3.3	3.3	1150			
		C <sub>14</sub> –C <sub>17</sub>	3.3	5.0	1150			
I <sub>IH</sub>	Maximum Input Current in HIGH State	A <sub>9</sub> –A <sub>13</sub> , PLH <sub>IN</sub> , HD, DIR, HLH <sub>IN</sub>	3.6	3.6	1.0	μA	V <sub>I</sub> = 3.6V	
		C <sub>14</sub> –C <sub>17</sub>	3.6	3.6	50.0		V <sub>I</sub> = 3.6V	
		C <sub>14</sub> –C <sub>17</sub>	3.6	5.5	100		V <sub>I</sub> = 5.5V	
I <sub>IL</sub>	Maximum Input Current in LOW State	A <sub>9</sub> –A <sub>13</sub> , PLH <sub>IN</sub> , HD, DIR, HLH <sub>IN</sub>	3.6	3.6	-1.0	μA	V <sub>I</sub> = 0.0V	
		C <sub>14</sub> –C <sub>17</sub>	3.6	3.6	-3.5		mA	V <sub>I</sub> = 0.0V
		C <sub>14</sub> –C <sub>17</sub>	3.6	5.5	-5.0		mA	V <sub>I</sub> = 0.0V
I <sub>OZH</sub>	Maximum Output Disable Current (HIGH)	A <sub>1</sub> –A <sub>8</sub>	3.6	3.6	20	μA	V <sub>O</sub> = 3.6V	
		B <sub>1</sub> –B <sub>8</sub>	3.6	3.6	50		V <sub>O</sub> = 3.6V	
		B <sub>1</sub> –B <sub>8</sub>	3.6	5.5	100		V <sub>O</sub> = 5.5V	
I <sub>OZL</sub>	Maximum Output Disable Current (LOW)	A <sub>1</sub> –A <sub>8</sub>	3.6	3.6	-20	μA	V <sub>O</sub> = 0.0V	
		B <sub>1</sub> –B <sub>8</sub>	3.6	3.6	-3.5		mA	
		B <sub>1</sub> –B <sub>8</sub>	3.6	5.5	-5.0		mA	
I <sub>OFF</sub>	Power Down Output Leakage	B <sub>1</sub> –B <sub>8</sub> , Y <sub>9</sub> –Y <sub>13</sub> , PLH	0.0	0.0	100	μA	V <sub>O</sub> = 5.5V	
I <sub>OFF</sub>	Power Down Input Leakage	C <sub>14</sub> –C <sub>17</sub> , HLH <sub>IN</sub>	0.0	0.0	100	μA	V <sub>I</sub> = 5.5V	
I <sub>OFF—ICC</sub>	PowerDown Leakage to V <sub>CC</sub>		0.0	0.0	250	μA	(Note 6)	
I <sub>OFF—ICC2</sub>	Power Down Leakage to V <sub>CC—Cable</sub>		0.0	0.0	250	μA	(Note 6)	
I <sub>CC</sub>	Maximum Supply Current		3.6	3.6	45	mA	V <sub>I</sub> = V <sub>CC</sub> or GND	
			3.6	5.5	70		V <sub>I</sub> = V <sub>CC</sub> or GND	

**Note 5:** Output impedance is measured with the output active LOW and active HIGH (HD = HIGH).

**Note 6:** Power-down leakage to V<sub>CC</sub> or V<sub>CC—Cable</sub> is tested by simultaneously forcing all pins on the cable-side (B<sub>1</sub>–B<sub>8</sub>, Y<sub>9</sub>–Y<sub>13</sub>, PLH, C<sub>14</sub>–C<sub>17</sub> and HLH<sub>IN</sub>) to 5.5V and measuring the resulting I<sub>CC</sub> or I<sub>CC—Cable</sub>.

**Note 7:** This parameter is guaranteed but not tested, characterized only.

## AC Electrical Characteristics

Symbol	Parameter	$T_A = -40^\circ\text{C to } +85^\circ\text{C}$ $V_{CC} = 3.0\text{V}-3.6\text{V}$ $V_{CC-Cable} = 4.5\text{V}-5.5\text{V}$		Units	Figure Number
		Min	Max		
$t_{PHL}$	A <sub>1</sub> -A <sub>8</sub> to B <sub>1</sub> -B <sub>8</sub>	1.0	8.5	ns	Figure 1
$t_{PLH}$	A <sub>1</sub> -A <sub>8</sub> to B <sub>1</sub> -B <sub>8</sub>	1.0	8.5	ns	Figure 2
$t_{PHL}$	B <sub>1</sub> -B <sub>8</sub> to A <sub>1</sub> -A <sub>8</sub>	1.0	14.0	ns	Figure 3
$t_{PLH}$	B <sub>1</sub> -B <sub>8</sub> to A <sub>1</sub> -A <sub>8</sub>	1.0	14.0	ns	Figure 3
$t_{PHL}$	A <sub>9</sub> -A <sub>13</sub> to Y <sub>9</sub> -Y <sub>13</sub>	1.0	8.5	ns	Figure 1
$t_{PLH}$	A <sub>9</sub> -A <sub>13</sub> to Y <sub>9</sub> -Y <sub>13</sub>	1.0	8.5	ns	Figure 2
$t_{PHL}$	C <sub>14</sub> -C <sub>17</sub> to A <sub>14</sub> -A <sub>17</sub>	1.0	10.0	ns	Figure 3
$t_{PLH}$	C <sub>14</sub> -C <sub>17</sub> to A <sub>14</sub> -A <sub>17</sub>	1.0	10.0	ns	Figure 3
$t_{SKEW}$	LH-LH or HL-HL		2.0	ns	(Note 8)
$t_{PHL}$	PLH <sub>IN</sub> to PLH	1.0	8.5	ns	Figure 1
$t_{PLH}$	PLH <sub>IN</sub> to PLH	1.0	8.5	ns	Figure 2
$t_{PHL}$	HLH <sub>IN</sub> to HLH	1.0	10.0	ns	Figure 3
$t_{PLH}$	HLH <sub>IN</sub> to HLH	1.0	12.0	ns	Figure 3
$t_{PHZ}$	Output Disable Time	1.0	10.0	ns	Figure 4
$t_{PLZ}$	DIR to A <sub>1</sub> -A <sub>8</sub>	1.0	10.0	ns	Figure 4
$t_{PZH}$	Output Enable Time	1.0	10.0	ns	Figure 5
$t_{PZL}$	DIR to A <sub>1</sub> -A <sub>8</sub>	1.0	10.0	ns	Figure 5
$t_{PHZ}$	Output Disable Time	1.0	13.0	ns	Figure 6
$t_{PLZ}$	DIR to B <sub>1</sub> -B <sub>8</sub>	1.0	10.0	ns	Figure 6
$t_{pEN}$	Output Enable Time HD to B <sub>1</sub> -B <sub>8</sub> , Y <sub>9</sub> -Y <sub>13</sub>	1.0	8.0	ns	Figure 2
$t_{pDIS}$	Output Disable Time HD to B <sub>1</sub> -B <sub>8</sub> , Y <sub>9</sub> -Y <sub>13</sub>	1.0	12.0	ns	Figure 2

**Note 8:**  $t_{SKEW}$  is measured for common edge output transitions and compares the measured propagation delay for a given path type:

- (i) A<sub>1</sub>-A<sub>8</sub> to B<sub>1</sub>-B<sub>8</sub>, A<sub>9</sub>-A<sub>13</sub> to Y<sub>9</sub>-Y<sub>13</sub>
- (ii) B<sub>1</sub>-B<sub>8</sub> to A<sub>1</sub>-A<sub>8</sub>
- (iii) C<sub>14</sub>-C<sub>17</sub> to A<sub>14</sub>-A<sub>17</sub>

## Capacitance

Symbol	Parameter	Typ	Units	Conditions
$C_{IN}$	Input Capacitance	3	pF	$V_{CC} = 0.0\text{V}$ (HD, DIR, A <sub>9</sub> -A <sub>13</sub> , C <sub>14</sub> -C <sub>17</sub> , PLH <sub>IN</sub> and HLH <sub>IN</sub> )
$C_{I/O}$ (Note 9)	I/O Pin Capacitance	5	pF	$V_{CC} = 3.3\text{V}$

**Note 9:**  $C_{I/O}$  is measured at frequency = 1 MHz, per MIL-STD-883B, Method 3012

### AC Loading and Waveforms

Pulse Generator for all pulses: Rate  $\leq 1.0$  MHz;  $Z_O \leq 50\Omega$ ;  $t_r \leq 2.5$  ns,  $t_f \leq 2.5$  ns.

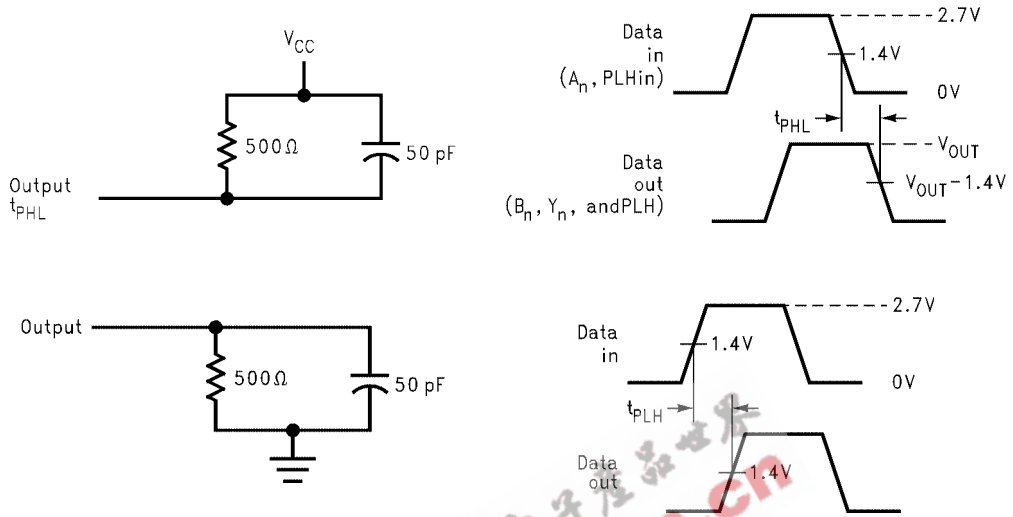

FIGURE 1. Port A to B and A to Y Propagation Delay Waveforms

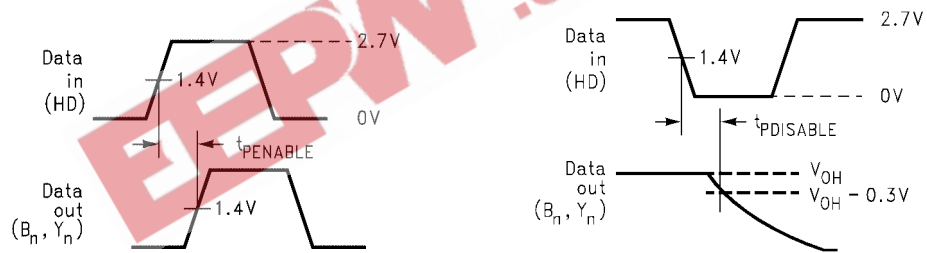

FIGURE 2. Port A to B and A to Y Output Waveforms

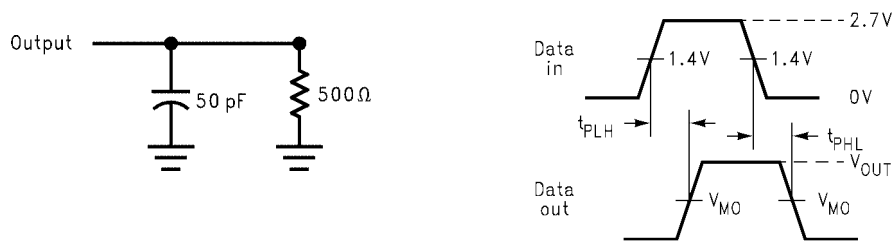

FIGURE 3. Port B to A, C to A and HLH in to HLH Propagation Delay Waveforms

AC Loading and Waveforms (Continued)

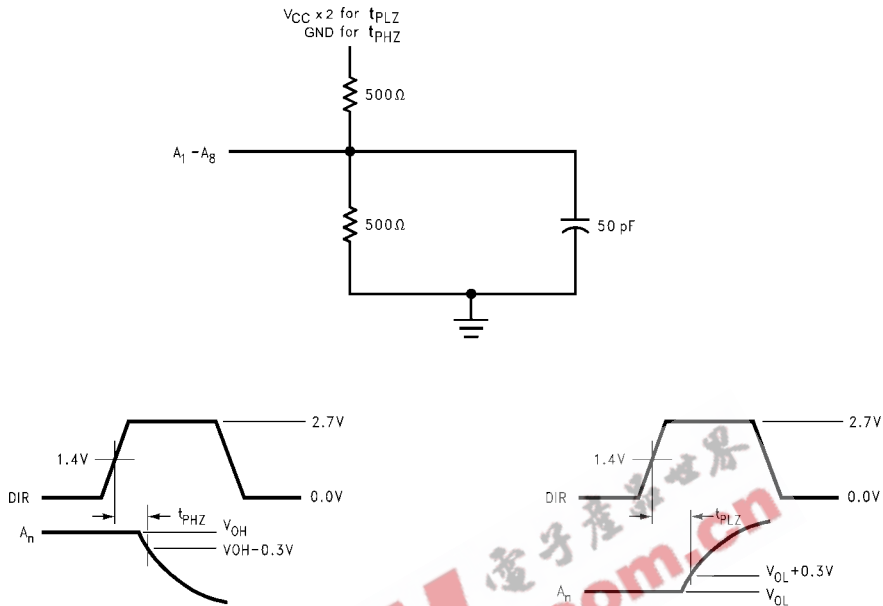

FIGURE 4.  $t_{PHZ}$  and  $t_{PLZ}$  Test Load and Waveforms, DIR to A<sub>1</sub> - A<sub>8</sub>

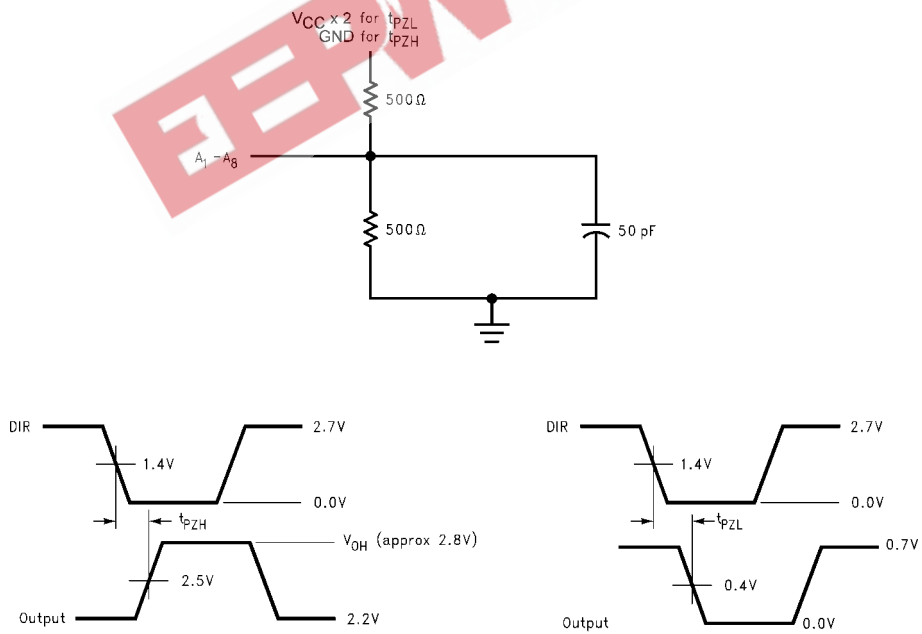

FIGURE 5.  $t_{PZH}$  and  $t_{PZL}$  Test Load and Waveforms, DIR to A<sub>1</sub> - A<sub>8</sub>

AC Loading and Waveforms (Continued)

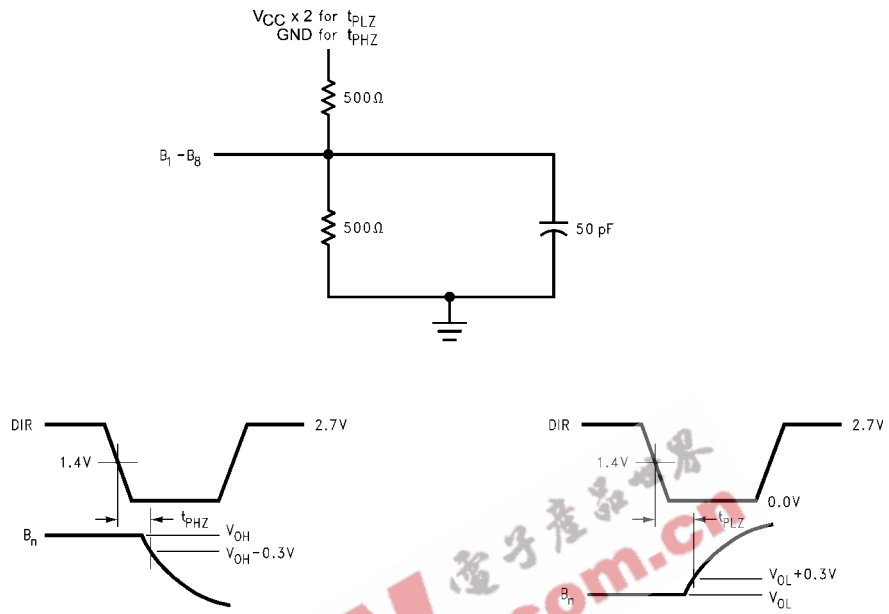
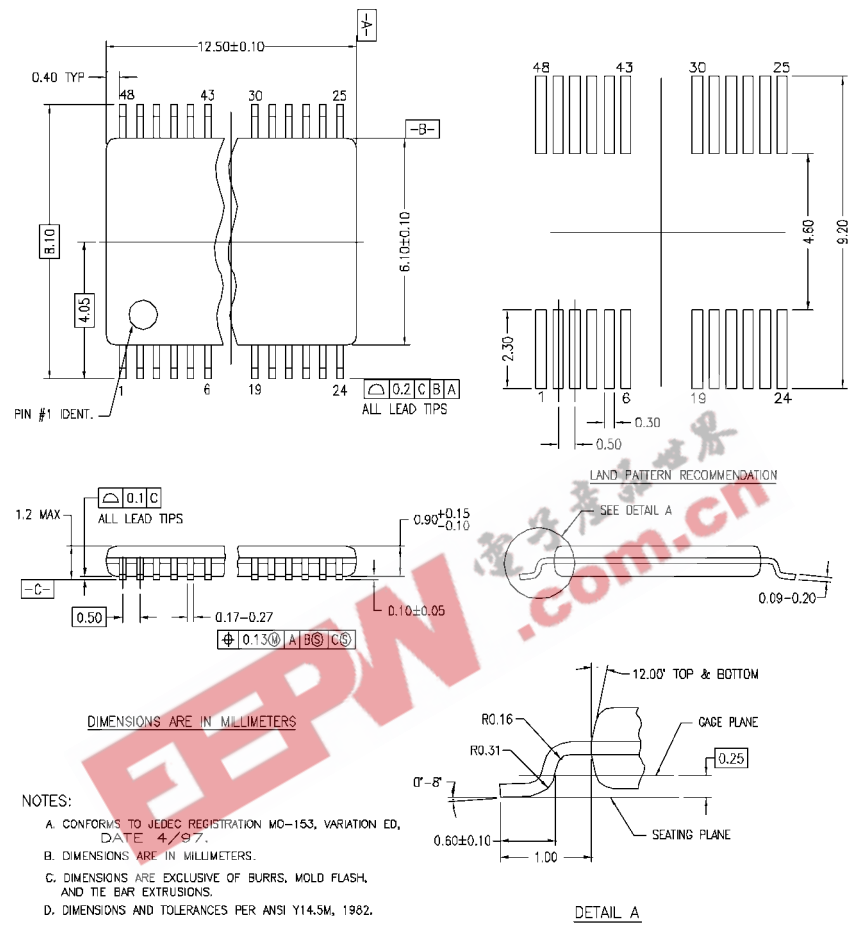

FIGURE 6.  $t_{PHZ}$  and  $t_{PLZ}$  Test Load and Waveforms, DIR to  $B_1-B_8$



**Physical Dimensions** inches (millimeters) unless otherwise noted



MTD48REV C

**48-Lead Thin Shrink Small Outline Package (TSSOP), JEDEC MO-153, 6.1mm Wide Package Number MTD48**

Fairchild does not assume any responsibility for use of any circuitry described, no circuit patent licenses are implied and Fairchild reserves the right at any time without notice to change said circuitry and specifications.

**LIFE SUPPORT POLICY**

FAIRCHILD'S PRODUCTS ARE NOT AUTHORIZED FOR USE AS CRITICAL COMPONENTS IN LIFE SUPPORT DEVICES OR SYSTEMS WITHOUT THE EXPRESS WRITTEN APPROVAL OF THE PRESIDENT OF FAIRCHILD SEMICONDUCTOR CORPORATION. As used herein:

1. Life support devices or systems are devices or systems which, (a) are intended for surgical implant into the body, or (b) support or sustain life, and (c) whose failure to perform when properly used in accordance with instructions for use provided in the labeling, can be reasonably expected to result in a significant injury to the user.
2. A critical component in any component of a life support device or system whose failure to perform can be reasonably expected to cause the failure of the life support device or system, or to affect its safety or effectiveness.

[www.fairchildsemi.com](http://www.fairchildsemi.com)