

## 54ACT/74ACT534 Octal D Flip-Flop with TRI-STATE® Outputs

### General Description

The 'ACT534 is a high-speed, low-power octal D-type flip-flop featuring separate D-type inputs for each flip-flop and TRI-STATE outputs for bus-oriented applications. A buffered Clock (CP) and Output Enable ( $\overline{OE}$ ) are common to all flip-flops. The 'ACT534 is the same as the 'ACT374 except that the outputs are inverted.

### Features

- $I_{CC}$  and  $I_{OZ}$  reduced by 50%
- Edge-triggered D-type inputs
- Buffered positive edge-triggered clock
- TRI-STATE outputs for bus-oriented applications
- Outputs source/sink 24 mA
- 'ACT534 has TTL-compatible inputs
- Inverted output version of 'ACT374

### Logic Symbols

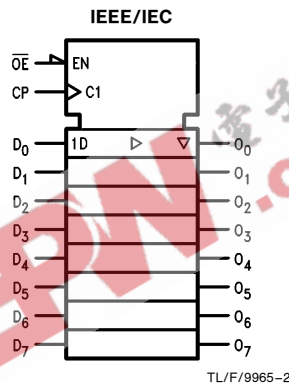
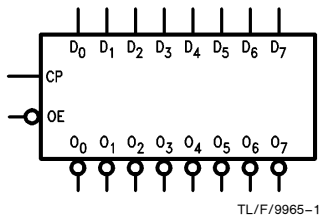

### Connection Diagrams

Pin Assignment  
for DIP, Flatpak and SOIC

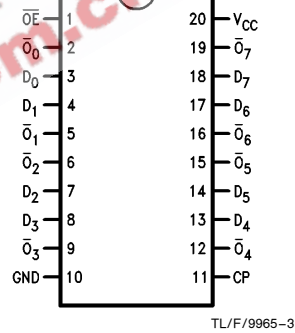

Pin Names	Description
D <sub>0</sub> -D <sub>7</sub>	Data Inputs
CP	Clock Pulse Input
$\overline{OE}$	TRI-STATE Output Enable Input
$\overline{O}_0$ - $\overline{O}_7$	Complementary TRI-STATE Outputs

Pin Assignment  
for LCC

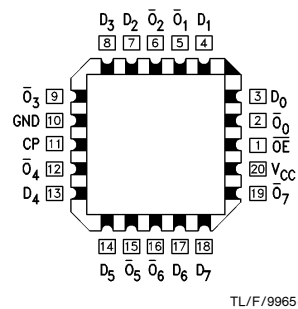

TRI-STATE® is a registered trademark of National Semiconductor Corporation.  
FACT™ is a trademark of National Semiconductor Corporation.

## Functional Description

The 'ACT534 consists of eight edge-triggered flip-flops with individual D-type inputs and TRI-STATE complementary outputs. The buffered clock and buffered Output Enable are common to all flip-flops. The eight flip-flops will store the state of their individual D inputs that meet the setup and hold times requirements on the LOW-to-HIGH Clock (CP)

transition. With the Output Enable ( $\overline{OE}$ ) LOW, the contents of the eight flip-flops are available at the outputs. When the  $\overline{OE}$  is HIGH, the outputs go to the high impedance state. Operation of the  $\overline{OE}$  input does not affect the state of the flip-flops.

## Logic Diagram

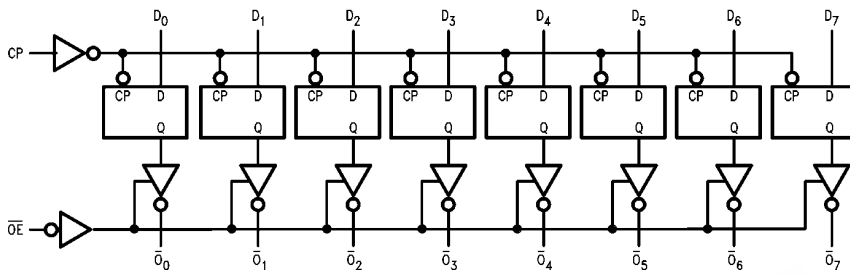

TL/F/9965-5

Please note that this diagram is provided only for the understanding of logic operations and should not be used to estimate propagation delays.

Function Table

Inputs			Output
CP	OE	D	$\overline{O}$
—	L	H	L
—	L	L	H
L	L	X	$\overline{O}_0$
X	H	X	Z

H = HIGH Voltage Level

L = LOW Voltage Level

X = Immaterial

— = LOW-to-HIGH Clock Transition

Z = High Impedance

$\overline{O}_0$  = Value stored from previous clock cycle

### Absolute Maximum Ratings (Note 1)

If Military/Aerospace specified devices are required, please contact the National Semiconductor Sales Office/Distributors for availability and specifications.

Supply Voltage ( $V_{CC}$ )	-0.5V to +7.0V
DC Input Diode Current ( $I_{IK}$ )	
$V_I = -0.5V$	-20 mA
$V_I = V_{CC} + 0.5V$	+20 mA
DC Input Voltage ( $V_I$ )	-0.5V to $V_{CC} + 0.5V$
DC Output Diode Current ( $I_{OK}$ )	
$V_O = -0.5V$	-20 mA
$V_O = V_{CC} + 0.5V$	+20 mA
DC Output Voltage ( $V_O$ )	-0.5V to $V_{CC} + 0.5V$
DC Output Source or Sink Current ( $I_O$ )	$\pm 50$ mA
DC $V_{CC}$ or Ground Current per Output Pin ( $I_{CC}$ or $I_{GND}$ )	$\pm 50$ mA
Storage Temperature ( $T_{STG}$ )	-65°C to +150°C
Junction Temperature ( $T_J$ )	
CDIP	175°C
PDIP	140°C

**Note 1:** Absolute maximum ratings are those values beyond which damage to the device may occur. The databook specifications should be met, without exception, to ensure that the system design is reliable over its power supply, temperature, and output/input loading variables. National does not recommend operation of FACT™ circuits outside databook specifications.

### Recommended Operating Conditions

Supply Voltage ( $V_{CC}$ )	4.5V to 5.5V
'ACT	
Input Voltage ( $V_I$ )	0V to $V_{CC}$
Output Voltage ( $V_O$ )	0V to $V_{CC}$
Operating Temperature ( $T_A$ )	
74ACT	-40°C to +85°C
54ACT	-55°C to +125°C
Minimum Input Edge Rate ( $\Delta V/\Delta t$ )	
'ACT Devices	
$V_{IN}$ from 0.8V to 2.0V	
$V_{CC}$ @ 4.5V, 5.5V	125 mV/ns

### DC Characteristics for 'ACT Family Devices

Symbol	Parameter	$V_{CC}$ (V)	74ACT			54ACT		74ACT		Units	Conditions
			$T_A = \pm 25^\circ C$			$T_A = -55^\circ C$ to $+125^\circ C$		$T_A = -40^\circ C$ to $+85^\circ C$			
			Typ	Guaranteed Limits							
$V_{IH}$	Minimum High Level Input Voltage	4.5	1.5	2.0	2.0	2.0	2.0	2.0	V	$V_{OUT} = 0.1V$ or $V_{CC} - 0.1V$	
		5.5	1.5	2.0	2.0	2.0	2.0	2.0			
$V_{IL}$	Maximum Low Level Input Voltage	4.5	1.5	0.8	0.8	0.8	0.8	0.8	V	$V_{OUT} = 0.1V$ or $V_{CC} - 0.1V$	
		5.5	1.5	0.8	0.8	0.8	0.8	0.8			
$V_{OH}$	Minimum High Level Output Voltage	4.5	4.49	4.4	4.4	4.4	4.4	4.4	V	$I_{OUT} = -50 \mu A$	
		5.5	5.49	5.4	5.4	5.4	5.4	5.4			
		4.5		3.86	3.70	3.76			V	$^*V_{IN} = V_{IL}$ or $V_{IH}$ $I_{OH} = -24 mA$	
		5.5		4.86	4.70	4.76					
$V_{OL}$	Maximum Low Level Output Voltage	4.5	0.001	0.1	0.1	0.1	0.1	0.1	V	$I_{OUT} = 50 \mu A$	
		5.5	0.001	0.1	0.1	0.1	0.1	0.1			
		4.5		0.36	0.50	0.44			V	$^*V_{IN} = V_{IL}$ or $V_{IH}$ $I_{OL} = 24 mA$	
		5.5		0.36	0.50	0.44					
$I_{IN}$	Maximum Input Leakage Current	5.5		$\pm 0.1$	$\pm 1.0$	$\pm 1.0$	$\pm 1.0$	$\pm 1.0$	$\mu A$	$V_I = V_{CC}, GND$	
$I_{OZ}$	Maximum TRI-STATE® Current	5.5		$\pm 0.25$	$\pm 5.0$	$\pm 5.0$	$\pm 2.5$	$\pm 2.5$	$\mu A$	$V_I = V_{IL}, V_{IH}$ $V_O = V_{CC}, GND$	
$I_{CCT}$	Maximum $I_{CC}/Input$	5.5	0.6		1.6	1.5	1.5	1.5	mA	$V_I = V_{CC} - 2.1V$	

\*All outputs loaded; thresholds on input associated with output under test.

## DC Characteristics for 'ACT Family Devices (Continued)

Symbol	Parameter	V <sub>CC</sub> (V)	74ACT		54ACT		74ACT		Units	Conditions
			T <sub>A</sub> = +25°C		T <sub>A</sub> = -55°C to +125°C		T <sub>A</sub> = -40°C to +85°C			
			Typ	Guaranteed Limits						
I <sub>OLD</sub>	† Minimum Dynamic Output Current	5.5			50		75		mA	V <sub>OLD</sub> = 1.65V Max
I <sub>OHD</sub>		5.5			-50		-75		mA	V <sub>OHD</sub> = 3.85V Min
I <sub>CC</sub>	Maximum Quiescent Supply Current	5.5		4.0	80.0		40.0		μA	V <sub>IN</sub> = V <sub>CC</sub> or GND

† Maximum test duration 2.0 ms, one output loaded at a time.

Note: I<sub>CC</sub> for 54ACT @ 25°C is identical to 74ACT @ 25°C.

## AC Electrical Characteristics

Symbol	Parameter	V <sub>CC</sub> * (V)	74ACT			54ACT		74ACT		Units
			T <sub>A</sub> = +25°C C <sub>L</sub> = 50 pF			T <sub>A</sub> = -55°C to +125°C C <sub>L</sub> = 50 pF		T <sub>A</sub> = -40°C to +85°C C <sub>L</sub> = 50 pF		
			Min	Typ	Max	Min	Max	Min	Max	
f <sub>max</sub>	Maximum Clock Frequency	5.0		100		85		120	MHz	
t <sub>PLH</sub>	Propagation Delay CP to Q <sub>n</sub>	5.0	2.5	6.5	11.5	1.5	14.0	2.0	12.5	ns
t <sub>PHL</sub>	Propagation Delay CP to Q <sub>n</sub>	5.0	2.0	6.0	10.5	1.5	13.0	2.0	12.0	ns
t <sub>PZH</sub>	Output Enable Time	5.0	2.5	6.5	12.0	1.5	14.0	2.0	12.5	ns
t <sub>PZL</sub>	Output Enable Time	5.0	2.0	6.0	11.0	1.5	13.0	2.0	11.5	ns
t <sub>PHZ</sub>	Output Disable Time	5.0	1.5	7.0	12.5	1.5	14.5	1.0	13.5	ns
t <sub>PLZ</sub>	Output Disable Time	5.0	1.5	5.5	10.5	1.5	11.5	1.0	10.5	ns

\*Voltage Range 5.0 is 5.0V ±0.5V

## AC Operating Requirements

Symbol	Parameter	V <sub>CC</sub> * (V)	74ACT		54ACT		74ACT		Units
			T <sub>A</sub> = +25°C C <sub>L</sub> = 50 pF		T <sub>A</sub> = -55°C to +125°C C <sub>L</sub> = 50 pF		T <sub>A</sub> = -40°C to +85°C C <sub>L</sub> = 50 pF		
			Typ	Guaranteed Minimum					
t <sub>s</sub>	Setup Time, HIGH or LOW D <sub>n</sub> to CP	5.0	1.0	3.5	5.0	4.0			ns
t <sub>h</sub>	Hold Time, HIGH or LOW D <sub>n</sub> to CP	5.0	-1.0	1.0	3.0	1.5			ns
t <sub>w</sub>	CP Pulse Width HIGH or LOW	5.0	2.0	3.5	5.0	3.5			ns

\*Voltage Range 5.0 is 5.0V ±0.5V

## Capacitance

Symbol	Parameter	Typ	Units	Conditions
$C_{IN}$	Input Capacitance	4.5	pF	$V_{CC} = OPEN$
$C_{PD}$	Power Dissipation Capacitance	40.0	pF	$V_{CC} = 5.0V$

## Ordering Information

The device number is used to form part of a simplified purchasing code where the package type and temperature range are defined as follows:

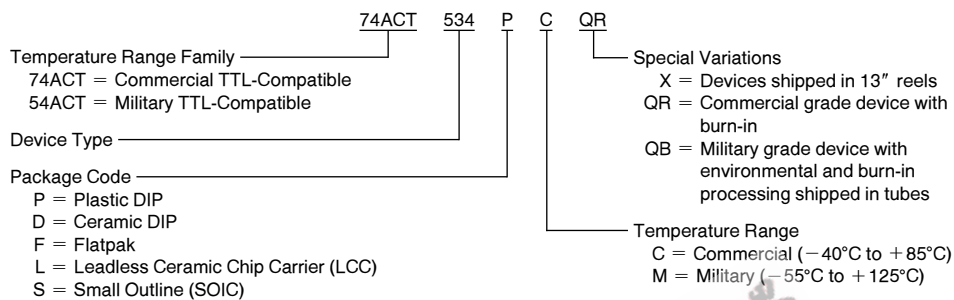

## Physical Dimensions inches (millimeters)

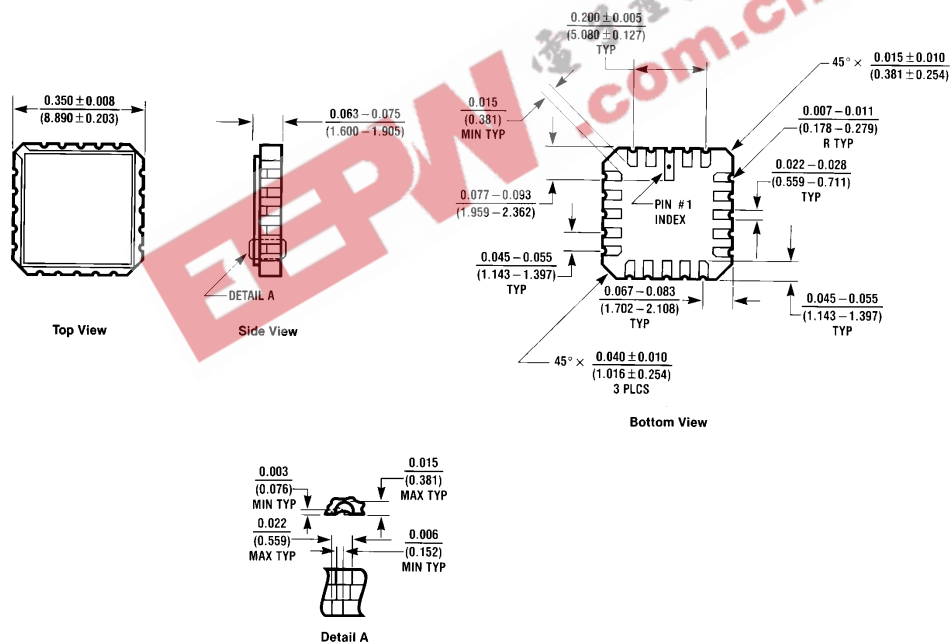

20 Terminal Ceramic Leadless Chip Carrier (L)  
 NS Package Number E20A

E20A (REV D)



**Physical Dimensions** inches (millimeters) (Continued)

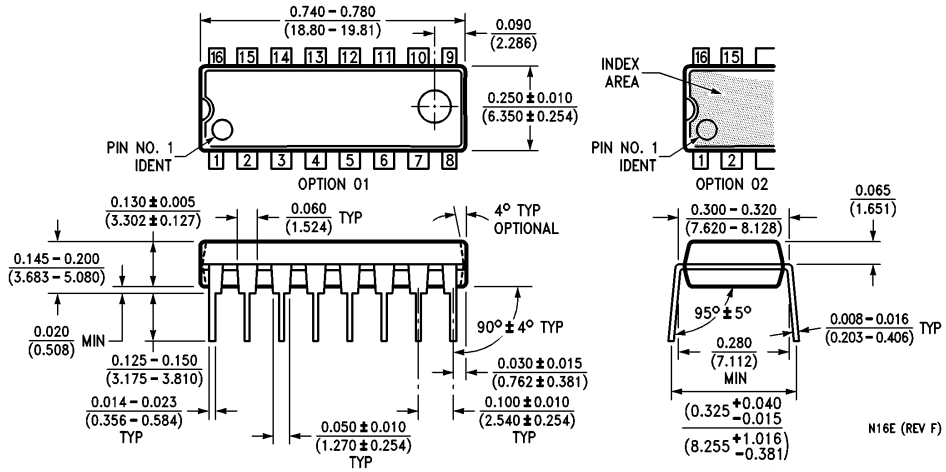

**16 Lead Plastic Dual-In-Line Package (P)**  
NS Package Number N16E

N16E (REV F)

EEPW.com.cn 电子产品世界

**Physical Dimensions** inches (millimeters) (Continued)

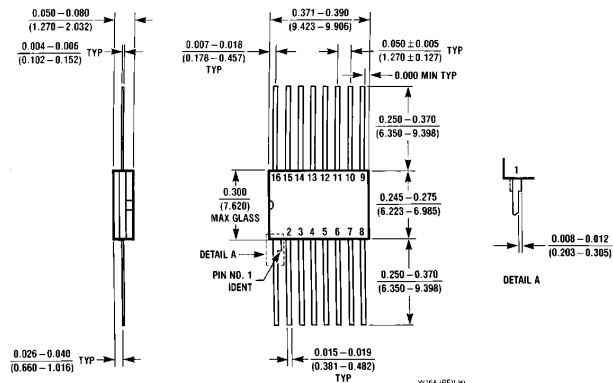

**16 Lead Ceramic Flatpak (F)  
NS Package Number W16A**



**LIFE SUPPORT POLICY**

NATIONAL'S PRODUCTS ARE NOT AUTHORIZED FOR USE AS CRITICAL COMPONENTS IN LIFE SUPPORT DEVICES OR SYSTEMS WITHOUT THE EXPRESS WRITTEN APPROVAL OF THE PRESIDENT OF NATIONAL SEMICONDUCTOR CORPORATION. As used herein:

1. Life support devices or systems are devices or systems which, (a) are intended for surgical implant into the body, or (b) support or sustain life, and whose failure to perform, when properly used in accordance with instructions for use provided in the labeling, can be reasonably expected to result in a significant injury to the user.
2. A critical component is any component of a life support device or system whose failure to perform can be reasonably expected to cause the failure of the life support device or system, or to affect its safety or effectiveness.

 <p><b>National Semiconductor Corporation</b> 2900 Semiconductor Drive P.O. Box 58090 Santa Clara, CA 95052-8090 Tel: 1 (800) 272-9959 TWX: (910) 339-9240</p>	<p><b>National Semiconductor GmbH</b> Livry-Gargan-Str. 10 D-82256 Fürstenfeldbruck Germany Tel: (81-41) 35-0 Telex: 527649 Fax: (81-41) 35-1</p>	<p><b>National Semiconductor Japan Ltd.</b> Sumitomo Chemical Engineering Center Bldg. 7F 1-7-1, Nakase, Mihama-Ku Chiba-City, Chiba Prefecture 261 Tel: (043) 299-2300 Fax: (043) 299-2500</p>	<p><b>National Semiconductor Hong Kong Ltd.</b> 13th Floor, Straight Block, Ocean Centre, 5 Canton Rd. Tsimshatsui, Kowloon Hong Kong Tel: (852) 2737-1600 Fax: (852) 2736-8960</p>	<p><b>National Semiconductores Do Brazil Ltda.</b> Rua Deputado Lacorda Franco 120-3A Sao Paulo-SP Brazil 05418-000 Tel: (55-11) 212-5066 Telex: 391-1131931 NSBR BR Fax: (55-11) 212-1181</p>	<p><b>National Semiconductor (Australia) Pty, Ltd.</b> Building 16 Business Park Drive Monash Business Park Nottingham, Melbourne Victoria 3168 Australia Tel: (3) 558-9889 Fax: (3) 558-9998</p>
---	---	---	---	--	---

National does not assume any responsibility for use of any circuitry described, no circuit patent licenses are implied and National reserves the right at any time without notice to change said circuitry and specifications.