

8-Bit Transceiver

Features

- Function, pinout, and drive compatible with FCT, and F logic
- FCT-D speed at 3.8 ns max. (Com'l), FCT-C speed at 4.1 ns max. (Com'l), FCT-A speed at 4.6 ns max. (Com'l)
- Reduced V_{OH} (typically = 3.3V) versions of equivalent FCT functions
- Edge-rate control circuitry for significantly improved noise characteristics
- Power-off disable feature
- ESD > 2000V
- Matched rise and fall times
- Fully compatible with TTL input and output logic levels
- Extended commercial range of -40°C to $+85^{\circ}\text{C}$
- Sink current 64 mA (Com'l), 48 mA (Mil)
- Source current 32 mA (Com'l), 12 mA (Mil)

Functional Description

The FCT245T contains eight non-inverting bidirectional buffers with three-state outputs and is intended for bus oriented applications. For the FCT245T, current sinking capability is 64 mA at the A and B ports.

The Transmit/Receiver (T/\bar{R}) input determines the direction of data flow through bidirectional transceiver. Transmit (Active HIGH) enables data from A ports to B ports. The output enable (\overline{OE}), when HIGH, disables both the A and B ports by putting them in a High Z condition.

The outputs are designed with a power-off disable feature to allow for live insertion of boards.

Logic Block Diagram

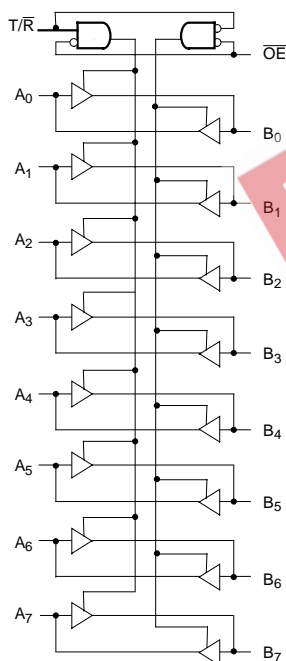

Pin Configurations

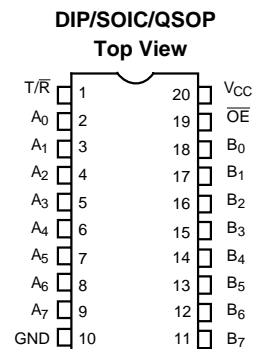
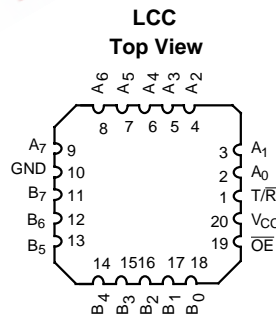

Function Table^[1]

\overline{OE}	T/\bar{R}	Operation
L	L	B Data to Bus A
L	H	A Data to Bus B
H	X	High Z State

Note:

1. H = HIGH Voltage Level. L = LOW Voltage Level. X = Don't Care.

Maximum Ratings^[2,3]

(Above which the useful life may be impaired. For user guidelines, not tested.)

Storage Temperature	-65°C to +150°C
Ambient Temperature with Power Applied	-65°C to +135°C
Supply Voltage to Ground Potential.....	-0.5V to +7.0V
DC Input Voltage	-0.5V to +7.0V
DC Output Voltage	-0.5V to +7.0V
DC Output Current (Maximum Sink Current/Pin).....	120 mA

Power Dissipation	0.5W
Static Discharge Voltage.....	>2001V (per MIL-STD-883, Method 3015)

Operating Range

Range	Range	Ambient Temperature	V _{CC}
Commercial	DT	0°C to +70°C	5V ± 5%
Commercial	T, AT, CT	-40°C to +85°C	5V ± 5%
Military ^[4]	All	-55°C to +125°C	5V ± 10%

Electrical Characteristics Over the Operating Range

Parameter	Description	Test Conditions	Min.	Typ. ^[5]	Max.	Unit	
V _{OH}	Output HIGH Voltage	V _{CC} =Min., I _{OH} =-32 mA	Com'l	2.0		V	
		V _{CC} =Min., I _{OH} =-15 mA	Com'l	2.4	3.3	V	
		V _{CC} =Min., I _{OH} =-12 mA	Mil	2.4	3.3	V	
V _{OL}	Output LOW Voltage	V _{CC} =Min., I _{OL} =64 mA	Com'l		0.3	0.55	V
		V _{CC} =Min., I _{OL} =48mA	Mil		0.3	0.55	V
V _{IH}	Input HIGH Voltage		2.0			V	
V _{IL}	Input LOW Voltage				0.8	V	
V _H	Hysteresis ^[6]	All inputs		0.2		V	
V _{IK}	Input Clamp Diode Voltage	V _{CC} =Min., I _{IN} =-18 mA		-0.7	-1.2	V	
I _I	Input HIGH Current	V _{CC} =Max., V _{IN} =V _{CC}			5	μA	
I _{IH}	Input HIGH Current	V _{CC} =Max., V _{IN} =2.7V			±1	μA	
I _{IL}	Input LOW Current	V _{CC} =Max., V _{IN} =0.5V			±1	μA	
I _{OS}	Output Short Circuit Current ^[7]	V _{CC} =Max., V _{OUT} =0.0V	-60	-120	-225	mA	
I _{OFF}	Power-Off Disable	V _{CC} =0V, V _{OUT} =4.5V			±1	μA	

Capacitance^[6]

Parameter	Description	Typ. ^[5]	Max.	Unit
C _{IN}	Input Capacitance	5	10	pF
C _{OUT}	Output Capacitance	9	12	pF

Notes:

- Unless otherwise noted, these limits are over the operating free-air temperature range.
- Unused inputs must always be connected to an appropriate logic voltage level, preferably either V_{CC} or ground.
- T_A is the "instant on" case temperature.
- Typical values are at V_{CC}=5.0V, T_A=+25°C ambient.
- This parameter is specified but not tested.
- Not more than one output should be shorted at a time. Duration of short should not exceed one second. The use of high-speed test apparatus and/or sample and hold techniques are preferable in order to minimize internal chip heating and more accurately reflect operational values. Otherwise prolonged shorting of a high output may raise the chip temperature well above normal and thereby cause invalid readings in other parametric tests. In any sequence of parameter tests, I_{OS} tests should be performed last.

Power Supply Characteristics

Parameter	Description	Test Conditions	Typ. ^[5]	Max.	Unit
I_{CC}	Quiescent Power Supply Current	$V_{CC}=\text{Max.}, V_{IN}\leq 0.2\text{V}, V_{IN}\geq V_{CC}-0.2\text{V}$	0.1	0.2	mA
ΔI_{CC}	Quiescent Power Supply Current (TTL inputs HIGH)	$V_{CC}=\text{Max.}, V_{IN}=3.4\text{V},^{[8]}$ $f_1=0, \text{Outputs Open}$	0.5	2.0	mA
I_{CCD}	Dynamic Power Supply Current ^[9]	$V_{CC}=\text{Max.}, \text{One Input Toggling,}$ $50\% \text{ Duty Cycle, Outputs Open,}$ $\text{T/R or } \overline{\text{OE}}=\text{GND and}$ $V_{IN}\leq 0.2\text{V or } V_{IN}\geq V_{CC}-0.2\text{V}$	0.06	0.12	mA/MHz
I_C	Total Power Supply Current ^[10]	$V_{CC}=\text{Max.}, 50\% \text{ Duty Cycle, Outputs Open,}$ $\text{One Bit Toggling at } f_1=10 \text{ MHz,}$ $\text{T/R or } \overline{\text{OE}}=\text{GND and}$ $V_{IN}\leq 0.2\text{V or } V_{IN}\geq V_{CC}-0.2\text{V}$	0.7	1.4	mA
		$V_{CC}=\text{Max.}, 50\% \text{ Duty Cycle, Outputs Open,}$ $\text{One Bit Toggling at } f_1=10 \text{ MHz,}$ $\text{T/R or } \overline{\text{OE}}=\text{GND and } V_{IN}=3.4\text{V or } V_{IN}=\text{GND}$	1.2	3.4	mA
		$V_{CC}=\text{Max.}, 50\% \text{ Duty Cycle, Outputs Open,}$ $\text{Eight Bits Toggling at } f_1=2.5 \text{ MHz,}$ $\text{T/R or } \overline{\text{OE}}=\text{GND and}$ $V_{IN}\leq 0.2\text{V or } V_{IN}\geq V_{CC}-0.2\text{V}$	1.3	2.6 ^[11]	mA
		$V_{CC}=\text{Max.}, 50\% \text{ Duty Cycle, Outputs Open,}$ $\text{Eight Bits Toggling at } f_1=2.5 \text{ MHz,}$ $\text{T/R or } \overline{\text{OE}}=\text{GND and } V_{IN}=3.4\text{V or } V_{IN}=\text{GND}$	3.3	10.6 ^[11]	mA

Notes:

8. Per TTL driven input ($V_{IN}=3.4\text{V}$); all other inputs at V_{CC} or GND.
9. This parameter is not directly testable, but is derived for use in Total Power Supply calculations.
10. $I_C = I_{\text{QUIESCENT}} + I_{\text{INPUTS}} + I_{\text{DYNAMIC}}$
 $I_C = I_{CC} + \Delta I_{CC} D_H N_T + I_{CCD} (f_0/2 + f_1 N_1)$
 I_{CC} = Quiescent Current with CMOS input levels
 ΔI_{CC} = Power Supply Current for a TTL HIGH input ($V_{IN}=3.4\text{V}$)
 D_H = Duty Cycle for TTL inputs HIGH
 N_T = Number of TTL inputs at D_H
 I_{CCD} = Dynamic Current caused by an input transition pair (HLH or LHL)
 f_0 = Clock frequency for registered devices, otherwise zero
 f_1 = Input signal frequency
 N_1 = Number of inputs changing at f_1
 All currents are in milliamps and all frequencies are in megahertz.
11. Values for these conditions are examples of the I_{CC} formula. These limits are specified but not tested.

Switching Characteristics Over the Operating Range

Parameter	Description	FCT245T				FCT245AT				Unit	Fig. No. ^[13]
		Military		Commercial		Military		Commercial			
		Min. ^[12]	Max.	Min. ^[12]	Max.	Min. ^[12]	Max.	Min. ^[12]	Max.		
t _{PLH} t _{PHL}	Propagation Delay A to B or B to A	1.5	7.5	1.5	7.0	1.5	4.9	1.5	4.6	ns	1, 3
t _{PZH} t _{PZL}	Output Enable Time OE or T/R to A or B	1.5	10.0	1.5	9.5	1.5	6.5	1.5	6.2	ns	1, 7, 8
t _{PHZ} t _{PLZ}	Output Disable Time OE or T/R to A or B	1.5	10.0	1.5	7.5	1.5	6.0	1.5	5.0	ns	1, 7, 8

Switching Characteristics Over the Operating Range (continued)

Parameter	Description	FCT245CT				FCT245DT		Unit	Fig. No. ^[13]
		Military		Commercial		Commercial			
		Min. ^[12]	Max.	Min. ^[12]	Max.	Min. ^[12]	Max.		
t _{PLH} t _{PHL}	Propagation Delay A to B or B to A	1.5	4.5	1.5	4.1	1.5	3.8	ns	1, 3
t _{PZH} t _{PZL}	Output Enable Time OE or T/R to A or B	1.5	6.2	1.5	5.8	1.5	5.0	ns	1, 7, 8
t _{PHZ} t _{PLZ}	Output Disable Time OE or T/R to A or B	1.5	5.2	1.5	4.8	1.5	4.3	ns	1, 7, 8

Ordering Information

Speed (ns)	Ordering Code	Package Name	Package Type	Operating Range
3.8	CY74FCT245DTQCT	Q5	20-Lead (150-Mil) QSOP	Commercial
	CY74FCT245DTSOC/SOCT	S5	20-Lead (300-Mil) Molded SOIC	
4.1	CY74FCT245CTQCT	Q5	20-Lead (150-Mil) QSOP	Commercial
	CY74FCT245CTSOC/SOCT	S5	20-Lead (300-Mil) Molded SOIC	
4.5	CY54FCT245CTDMB	D6	20-Lead (300-Mil) CerDIP	Military
	CY54FCT245CTLMB	L61	20-Square Leadless Chip Carrier	
4.6	CY74FCT245ATPC	P5	20-Lead (300-Mil) Molded DIP	Commercial
	CY74FCT245ATQCT	Q5	20-Lead (150-Mil) QSOP	
	CY74FCT245ATSOC/SOCT	S5	20-Lead (300-Mil) Molded SOIC	
4.9	CY54FCT245ATDMB	D6	20-Lead (300-Mil) CerDIP	Military
	CY54FCT245ATLMB	L61	20-Square Leadless Chip Carrier	
7.0	CY74FCT245TQCT	Q5	20-Lead (150-Mil) QSOP	Commercial
	CY74FCT245TSOC/SOCT	S5	20-Lead (300-Mil) Molded SOIC	
7.5	CY54FCT245TDMB	D6	20-Lead (300-Mil) CerDIP	Military
	CY54FCT245TLMB	L61	20-Square Leadless Chip Carrier	

Notes:

12. Minimum limits are specified but not tested on Propagation Delays.
13. See "Parameter Measurement Information" in the General Information section.

Package Diagrams

20-Lead (300-Mil) CerDIP D6
MIL-STD-1835 D-8 Config.A

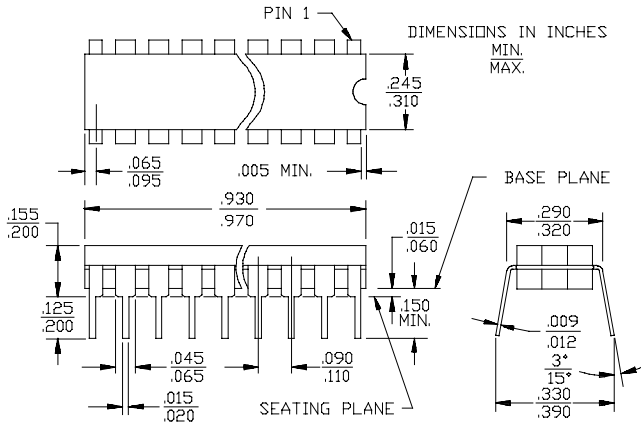

20-Pin Square Leadless Chip Carrier L61
MIL-STD-1835 C-2A

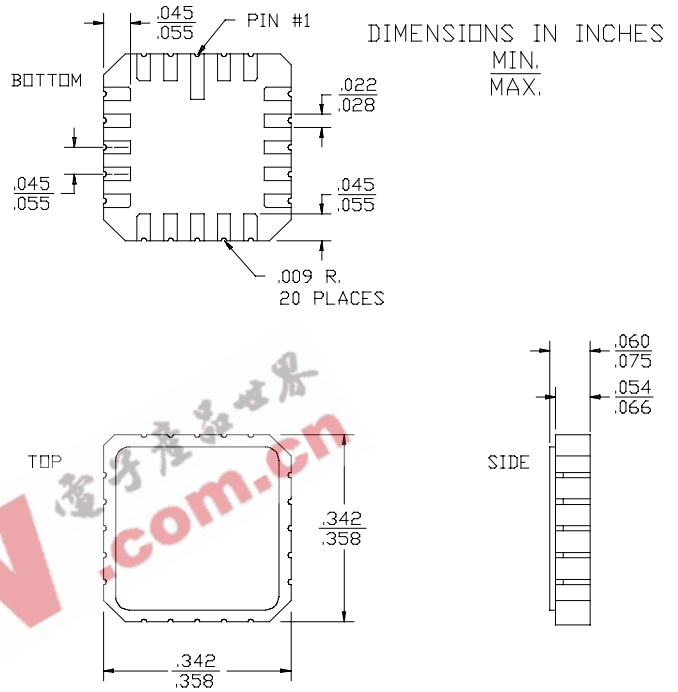

20-Lead (300-Mil) Molded DIP P5

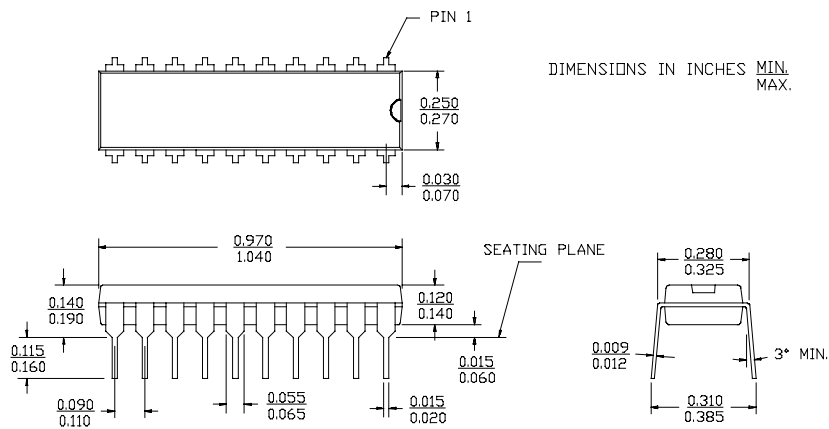

Package Diagrams (continued)

20-Lead Quarter Size Outline Q5

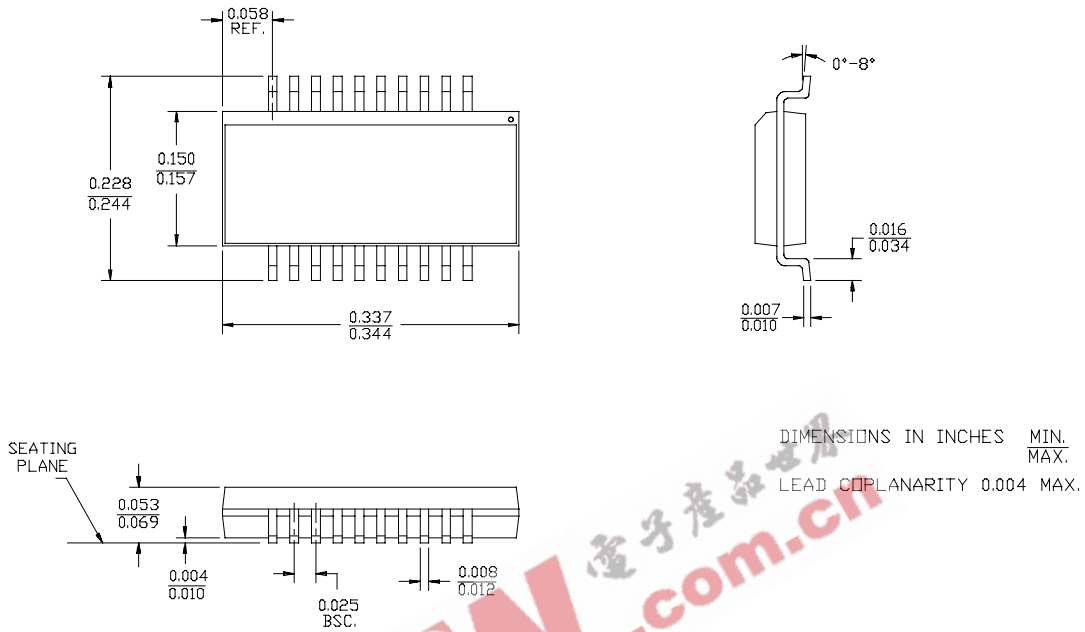

20-Lead (300-Mil) Molded SOIC S5

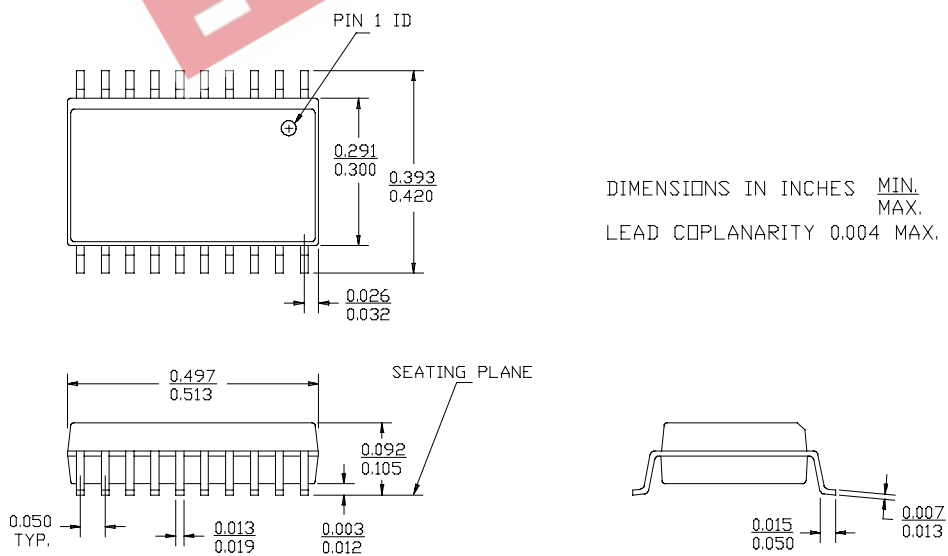

IMPORTANT NOTICE

Texas Instruments and its subsidiaries (TI) reserve the right to make changes to their products or to discontinue any product or service without notice, and advise customers to obtain the latest version of relevant information to verify, before placing orders, that information being relied on is current and complete. All products are sold subject to the terms and conditions of sale supplied at the time of order acknowledgement, including those pertaining to warranty, patent infringement, and limitation of liability.

TI warrants performance of its semiconductor products to the specifications applicable at the time of sale in accordance with TI's standard warranty. Testing and other quality control techniques are utilized to the extent TI deems necessary to support this warranty. Specific testing of all parameters of each device is not necessarily performed, except those mandated by government requirements.

CERTAIN APPLICATIONS USING SEMICONDUCTOR PRODUCTS MAY INVOLVE POTENTIAL RISKS OF DEATH, PERSONAL INJURY, OR SEVERE PROPERTY OR ENVIRONMENTAL DAMAGE ("CRITICAL APPLICATIONS"). TI SEMICONDUCTOR PRODUCTS ARE NOT DESIGNED, AUTHORIZED, OR WARRANTED TO BE SUITABLE FOR USE IN LIFE-SUPPORT DEVICES OR SYSTEMS OR OTHER CRITICAL APPLICATIONS. INCLUSION OF TI PRODUCTS IN SUCH APPLICATIONS IS UNDERSTOOD TO BE FULLY AT THE CUSTOMER'S RISK.

In order to minimize risks associated with the customer's applications, adequate design and operating safeguards must be provided by the customer to minimize inherent or procedural hazards.

TI assumes no liability for applications assistance or customer product design. TI does not warrant or represent that any license, either express or implied, is granted under any patent right, copyright, mask work right, or other intellectual property right of TI covering or relating to any combination, machine, or process in which such semiconductor products or services might be or are used. TI's publication of information regarding any third party's products or services does not constitute TI's approval, warranty or endorsement thereof.