

DATA SHEET

For a complete data sheet, please also download:

- The IC06 74HC/HCT/HCU/HCMOS Logic Family Specifications
- The IC06 74HC/HCT/HCU/HCMOS Logic Package Information
- The IC06 74HC/HCT/HCU/HCMOS Logic Package Outlines

EEPW 电子产品世界
.com.cn

74HC/HCT192

Presettable synchronous BCD
decade up/down counter

Product specification
File under Integrated Circuits, IC06

December 1990

Presettable synchronous BCD decade up/down counter

74HC/HCT192

FEATURES

- Synchronous reversible counting
- Asynchronous parallel load
- Asynchronous reset
- Expandable without external logic
- Output capability: standard
- I_{CC} category: MSI

GENERAL DESCRIPTION

The 74HC/HCT192 are high-speed Si-gate CMOS devices and are pin compatible with low power Schottky TTL (LSTTL). They are specified in compliance with JEDEC standard no. 7A.

The 74HC/HCT192 are synchronous BCD up/down counters. Separate up/down clocks, CP_U and CP_D respectively, simplify operation. The outputs change state synchronously with the LOW-to-HIGH transition of either clock input. If the CP_U clock is pulsed while CP_D is held HIGH, the device will count up. If the CP_D clock is pulsed while CP_U is held HIGH, the device will count down. Only one clock input can be held HIGH at any time, or erroneous operation will result. The device can be cleared at any time by the asynchronous master reset input (MR); it may also be loaded in parallel by activating the asynchronous parallel load input (PL).

The "192" contains four master-slave JK flip-flops with the necessary steering logic to provide the asynchronous reset, load, and synchronous count up and count down functions.

Each flip-flop contains JK feedback from slave to master, such that a LOW-to-HIGH transition on the CP_D input will decrease the count by one, while a similar transition on the CP_U input will advance the count by one.

One clock should be held HIGH while counting with the other, otherwise the circuit will either count by two's or not at all, depending on the state of the first flip-flop, which cannot toggle as long as either clock input is LOW.

Applications requiring reversible operation must make the reversing decision while the activating clock is HIGH to avoid erroneous counts.

The terminal count up (\overline{TC}_U) and terminal count down (\overline{TC}_D) outputs are normally HIGH. When the circuit has reached the maximum count state of 9, the next HIGH-to-LOW transition of CP_U will cause \overline{TC}_U to go LOW. \overline{TC}_U will stay LOW until CP_U goes HIGH again, duplicating the count up clock.

Likewise, the \overline{TC}_D output will go LOW when the circuit is in the zero state and the CP_D goes LOW. The terminal count outputs can be used as the clock input signals to the next higher order circuit in a multistage counter, since they duplicate the clock waveforms. Multistage counters will not be fully synchronous, since there is a slight delay time difference added for each stage that is added.

The counter may be preset by the asynchronous parallel load capability of the circuit. Information present on the parallel data inputs (D₀ to D₃) is loaded into the counter and appears on the outputs (Q₀ to Q₃) regardless of the conditions of the clock inputs when the parallel load (\overline{PL}) input is LOW. A HIGH level on the master reset (MR) input will disable the parallel load gates, override both clock inputs and set all outputs (Q₀ to Q₃) LOW. If one of the clock inputs is LOW during and after a reset or load operation, the next LOW-to-HIGH transition of that clock will be interpreted as a legitimate signal and will be counted.

Pre-settable synchronous BCD decade up/down counter

74HC/HCT192

QUICK REFERENCE DATAGND = 0 V; $T_{amb} = 25\text{ }^{\circ}\text{C}$; $t_r = t_f = 6\text{ ns}$

SYMBOL	PARAMETER	CONDITIONS	TYPICAL		UNIT
			HC	HCT	
t_{PHL}/t_{PLH}	propagation delay CP_D, CP_U to Q_n	$C_L = 15\text{ pF}; V_{CC} = 5\text{ V}$	20	20	ns
f_{max}	maximum clock frequency		40	45	MHz
C_I	input capacitance		3.5	3.5	pF
C_{PD}	power dissipation capacitance per package	notes 1 and 2	24	28	pF

Notes

1. C_{PD} is used to determine the dynamic power dissipation (P_D in μW):

$$P_D = C_{PD} \times V_{CC}^2 \times f_i + \sum (C_L \times V_{CC}^2 \times f_o) \text{ where:}$$

f_i = input frequency in MHz

f_o = output frequency in MHz

$\sum (C_L \times V_{CC}^2 \times f_o)$ = sum of outputs

C_L = output load capacitance in pF

V_{CC} = supply voltage in V

2. For HC the condition is $V_I = \text{GND to } V_{CC}$
 For HCT the condition is $V_I = \text{GND to } V_{CC} - 1.5\text{ V}$

ORDERING INFORMATION

See "74HC/HCT/HCU/HCMOS Logic Package Information".

Pre-settable synchronous BCD decade
up/down counter

74HC/HCT192

PIN DESCRIPTION

PIN NO.	SYMBOL	NAME AND FUNCTION
3, 2, 6, 7	Q ₀ to Q ₃	flip-flop outputs
4	CP _D	count down clock input ⁽¹⁾
5	CP _U	count up clock input ⁽¹⁾
8	GND	ground (0 V)
11	\overline{PL}	asynchronous parallel load input (active LOW)
12	\overline{TC}_U	terminal count up (carry) output (active LOW)
13	\overline{TC}_D	terminal count down (borrow) output (active LOW)
14	MR	asynchronous master reset input (active HIGH)
15, 1, 10, 9	D ₀ to D ₃	data inputs
16	V _{CC}	positive supply voltage

Note

1. LOW-to-HIGH, edge triggered

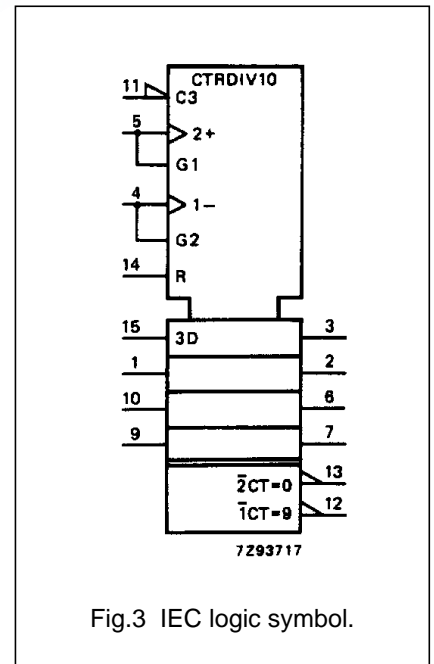
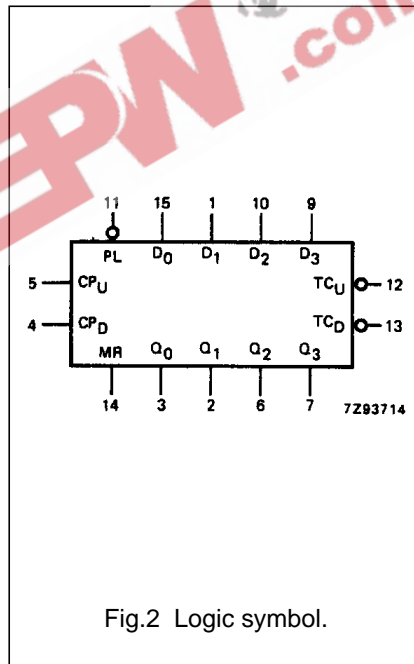
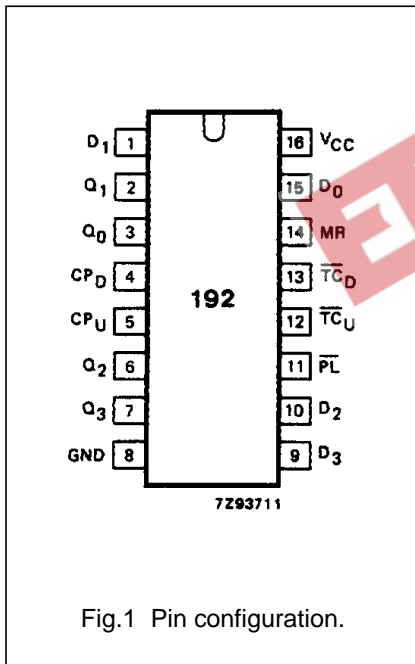

Pre-settable synchronous BCD decade
up/down counter

74HC/HCT192

FUNCTION TABLE

OPERATING MODE	INPUTS								OUTPUTS					
	MR	\overline{PL}	CP _U	CP _D	D ₀	D ₁	D ₂	D ₃	Q ₀	Q ₁	Q ₂	Q ₃	\overline{TC}_U	\overline{TC}_D
reset (clear)	H	X	X	L	X	X	X	X	L	L	L	L	H	L
	H	X	X	H	X	X	X	X	L	L	L	L	H	H
parallel load	L	L	X	L	L	L	L	L	L	L	L	L	H	L
	L	L	X	H	L	L	L	L	L	L	L	L	H	H
	L	L	L	X	H	X	X	H	Q _n = D _n			L	H	
count up	L	L	H	X	H	X	X	H	Q _n = D _n			H	H	
	L	H	↑	H	X	X	X	X	count up			H ⁽²⁾	H	
count down	L	H	H	↑	X	X	X	X	count down			H	H ⁽³⁾	

Notes

- H = HIGH voltage level
L = LOW voltage level
X = don't care
↑ = LOW-to-HIGH clock transition
- \overline{TC}_U = CP_U at terminal count up (HLLH)
- \overline{TC}_D = CP_D at terminal count down (LLLL)

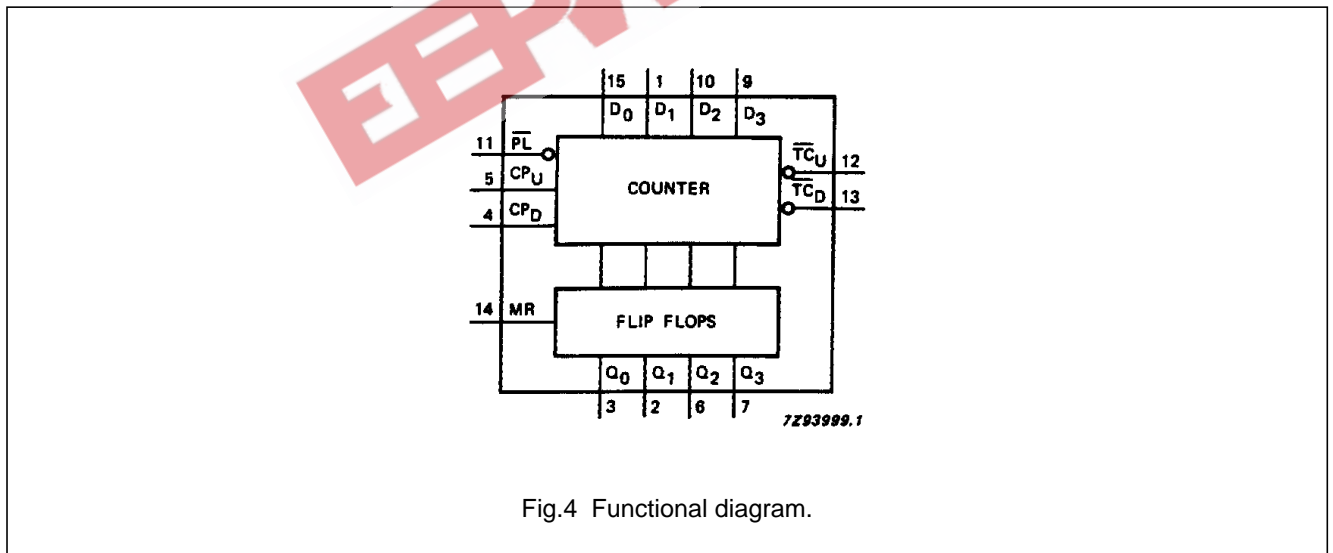
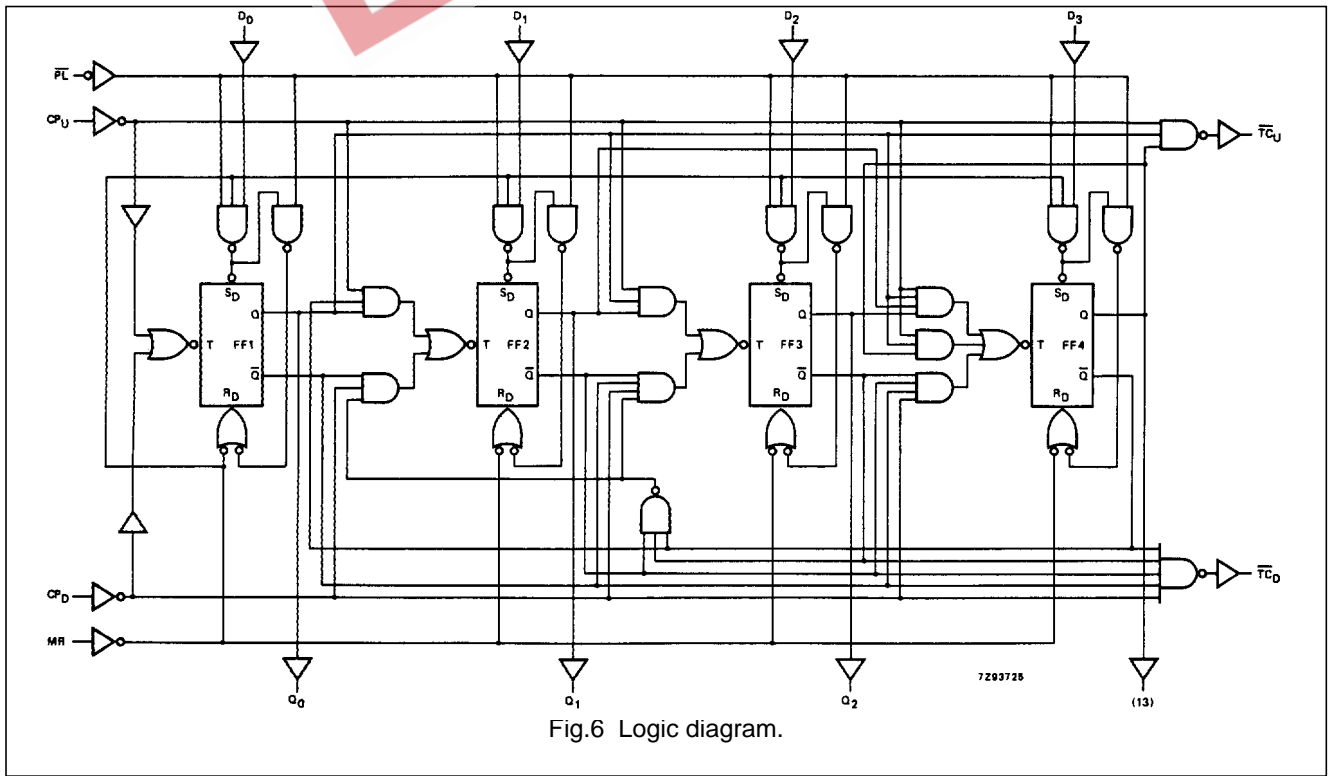
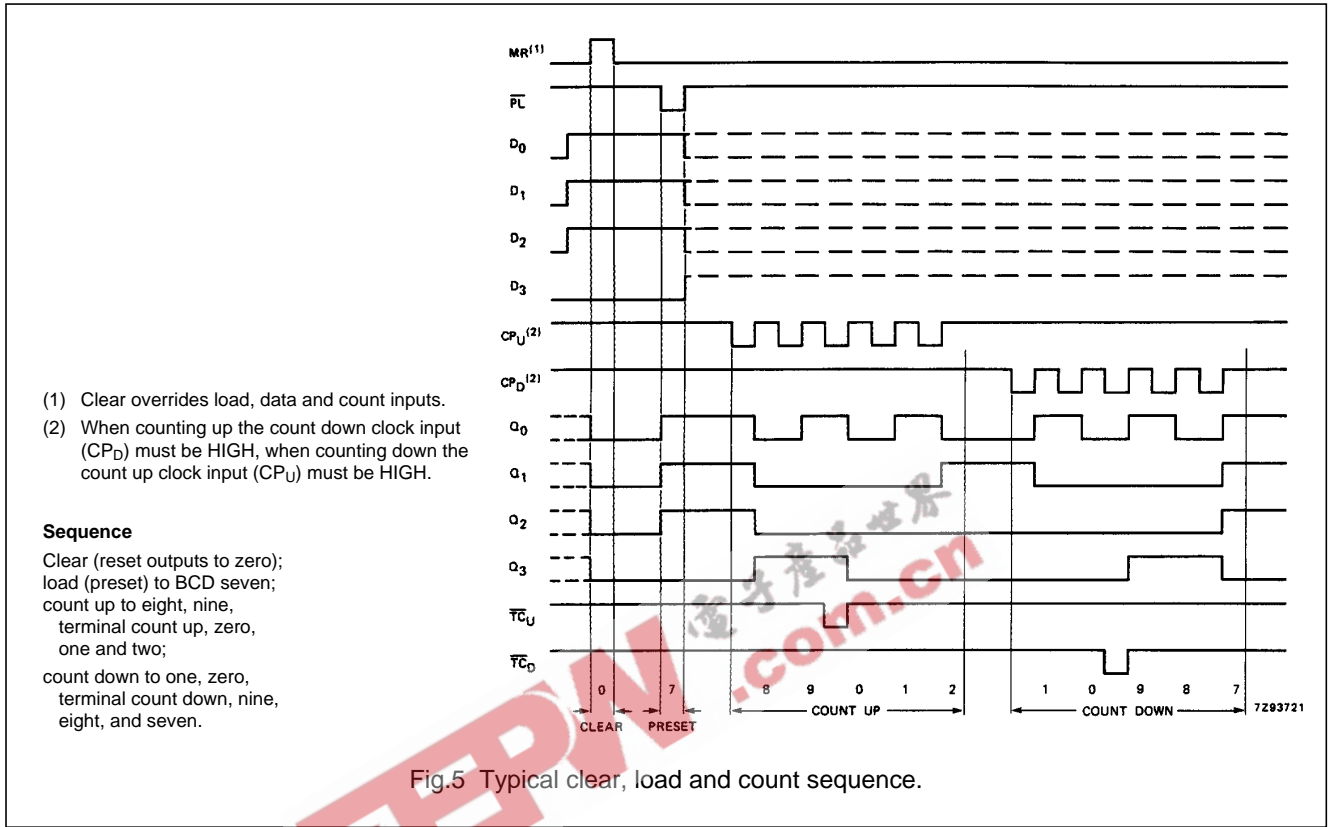

Fig.4 Functional diagram.

Pre-settable synchronous BCD decade
up/down counter

74HC/HCT192



Presetable synchronous BCD decade up/down counter

74HC/HCT192

DC CHARACTERISTICS FOR 74HC

For the DC characteristics see "74HC/HCT/HCU/HCMOS Logic Family Specifications".

Output capability: standard

I_{CC} category: MSI**AC CHARACTERISTICS FOR 74HC**GND = 0 V; t_r = t_f = 6 ns; C_L = 50 pF

SYMBOL	PARAMETER	T _{amb} (°C)						UNIT	TEST CONDITIONS		
		74HC							V _{CC} (V)	WAVEFORMS	
		+25			-40 to +85		-40 to +125				
		min.	typ.	max.	min.	max.	min.				max.
t _{PHL} / t _{PLH}	propagation delay CP _U , CP _D to Q _n		66 24 19	215 43 37		270 54 46	325 65 55	ns	2.0 4.5 6.0	Fig.7	
t _{PHL} / t _{PLH}	propagation delay CP _U to TC _U		33 12 10	125 25 21		155 31 26	190 38 32	ns	2.0 4.5 6.0	Fig.8	
t _{PHL} / t _{PLH}	propagation delay CP _D to TC _D		39 14 11	125 25 21		155 31 26	190 38 32	ns	2.0 4.5 6.0	Fig.8	
t _{PHL} / t _{PLH}	propagation delay PL to Q _n		69 25 20	215 43 37		270 54 46	325 65 55	ns	2.0 4.5 6.0	Fig.9	
t _{PHL}	propagation delay MR to Q _n		63 23 18	200 40 34		250 50 43	300 60 51	ns	2.0 4.5 6.0	Fig.10	
t _{PHL}	propagation delay D _n to Q _n		91 33 26	275 55 47		345 69 59	415 83 71	ns	2.0 4.5 6.0	Fig.9	
t _{PLH}	propagation delay D _n to Q _n		80 29 23	240 48 41		300 60 51	360 72 61	ns	2.0 4.5 6.0	Fig.9	
t _{PHL} / t _{PLH}	propagation delay PL to TC _U , PL to TC _D		102 37 30	315 63 54		395 79 67	475 95 81	ns	2.0 4.5 6.0	Fig.12	
t _{PHL} / t _{PLH}	propagation delay MR to TC _U , MR to TC _D		96 35 28	285 57 48		355 71 60	430 86 73	ns	2.0 4.5 6.0	Fig.12	
t _{PHL} / t _{PLH}	propagation delay D _n to TC _U , D _n to TC _D		83 30 24	290 58 49		365 73 62	435 87 74	ns	2.0 4.5 6.0	Fig.12	
t _{THL} / t _{TLH}	output transition time		19 7 6	75 15 13		95 19 16	110 22 19	ns	2.0 4.5 6.0	Fig.10	

Pre-settable synchronous BCD decade up/down counter

74HC/HCT192

SYMBOL	PARAMETER	T _{amb} (°C)						UNIT	TEST CONDITIONS		
		74HC							V _{CC} (V)	WAVEFORMS	
		+25			-40 to +85		-40 to +125				
		min.	typ.	max.	min.	max.	min.				max.
t _w	up clock pulse width HIGH or LOW	120 24 20	39 14 11		150 30 26		180 36 31	ns	2.0 4.5 6.0	Fig.7	
t _w	down clock pulse width HIGH or LOW	140 28 24	50 18 14		175 35 30		210 42 36	ns	2.0 4.5 6.0	Fig.7	
t _w	master reset pulse width HIGH	80 16 14	22 8 6		100 20 17		120 24 20	ns	2.0 4.5 6.0	Fig.10	
t _w	parallel load pulse width LOW	80 16 14	22 8 6		100 20 17		120 24 20	ns	2.0 4.5 6.0	Fig.9	
t _{rem}	removal time PL to CP _U , CP _D	50 10 9	3 1 1		65 13 11		75 15 13	ns	2.0 4.5 6.0	Fig.9	
t _{rem}	removal time MR to CP _U , CP _D	50 10 9	0 0 0		65 13 11		75 15 13	ns	2.0 4.5 6.0	Fig.10	
t _{su}	set-up time D _n to PL	80 16 14	22 8 6		100 20 17		120 24 20	ns	2.0 4.5 6.0	Fig.11 note: CP _U = CP _D = HIGH	
t _h	hold time D _n to PL	0 0 0	-14 -5 -4		0 0 0		0 0 0	ns	2.0 4.5 6.0	Fig.11	
t _h	hold time CP _U to CP _D , CP _D to CP _U	80 16 14	19 7 6		100 20 17		120 24 20	ns	2.0 4.5 6.0	Fig.13	
f _{max}	maximum up, down clock pulse frequency	4.0 20 24	12 36 43		3.2 16 19		2.6 13 15	MHz	2.0 4.5 6.0	Fig.7	

**Pre-settable synchronous BCD decade
up/down counter**

74HC/HCT192**DC CHARACTERISTICS FOR 74HCT**

For the DC characteristics see *"74HC/HCT/HCU/HCMOS Logic Family Specifications"*.

Output capability: standard

I_{CC} category: MSI

Note to HCT types

The value of additional quiescent supply current (ΔI_{CC}) for a unit load of 1 is given in the family specifications. To determine ΔI_{CC} per input, multiply this value by the unit load coefficient shown in the table below.

INPUT	UNIT LOAD COEFFICIENT
D _n	0.35
CP _U , CP _D	1.40
\overline{PL}	0.65
MR	1.05

EEPW 电子产品世界
.com.cn

Presettable synchronous BCD decade up/down counter

74HC/HCT192

AC CHARACTERISTICS FOR 74HCTGND = 0 V; $t_r = t_f = 6$ ns; $C_L = 50$ pF

SYMBOL	PARAMETER	T_{amb} (°C)						UNIT	TEST CONDITIONS		
		74HCT							V_{CC} (V)	WAVEFORMS	
		+25			-40 to +85		-40 to +125				
		min.	typ.	max.	min.	max.	min.				max.
t_{PHL}/t_{PLH}	propagation delay CP _U , CP _D to Q _n		23	43		54		65	ns	4.5	Fig.7
t_{PHL}/t_{PLH}	propagation delay CP _U to \overline{TC}_U		16	30		38		45	ns	4.5	Fig.8
t_{PHL}/t_{PLH}	propagation delay CP _D to \overline{TC}_D		17	30		38		45	ns	4.5	Fig.8
t_{PHL}/t_{PLH}	propagation delay \overline{PL} to Q _n		28	46		58		69	ns	4.5	Fig.9
t_{PHL}	propagation delay MR to Q _n		24	40		50		60	ns	4.5	Fig.10
t_{PHL}/t_{PLH}	propagation delay D _n to Q _n		36	62		78		93	ns	4.5	Fig.9
t_{PHL}/t_{PLH}	propagation delay \overline{PL} to \overline{TC}_U , \overline{PL} to \overline{TC}_D		36	64		80		96	ns	4.5	Fig.12
t_{PHL}/t_{PLH}	propagation delay MR to \overline{TC}_U , MR to \overline{TC}_D		36	64		80		96	ns	4.5	Fig.12
t_{PHL}/t_{PLH}	propagation delay D _n to \overline{TC}_U , D _n to \overline{TC}_D		33	58		73		87	ns	4.5	Fig.12
t_{THL}/t_{TLH}	output transition time		7	15		19		22	ns	4.5	Fig.10
t_W	up, down clock pulse width HIGH or LOW	25	14		31		38		ns	4.5	Fig.7
t_W	master reset pulse width HIGH	16	6		20		24		ns	4.5	Fig.10
t_W	parallel load pulse width LOW	20	10		25		30		ns	4.5	Fig.9
t_{rem}	removal time \overline{PL} to CP _U , CP _D	10	1		13		15		ns	4.5	Fig.9
t_{rem}	removal time MR to CP _U , CP _D	10	2		13		15		ns	4.5	Fig.10
t_{su}	set-up time D _n to \overline{PL}	16	8		20		24		ns	4.5	Fig.11 note: CP _U = CP _D = HIGH
t_h	hold time D _n to \overline{PL}	0	-6		0		0		ns	4.5	Fig.11
t_h	hold time CP _U to CP _D , CP _D to CP _U	20	9		25		30		ns	4.5	Fig.13
f_{max}	maximum up, down clock pulse frequency	20	41		16		13		MHz	4.5	Fig.7

Pre-settable synchronous BCD decade up/down counter

74HC/HCT192

AC WAVEFORMS

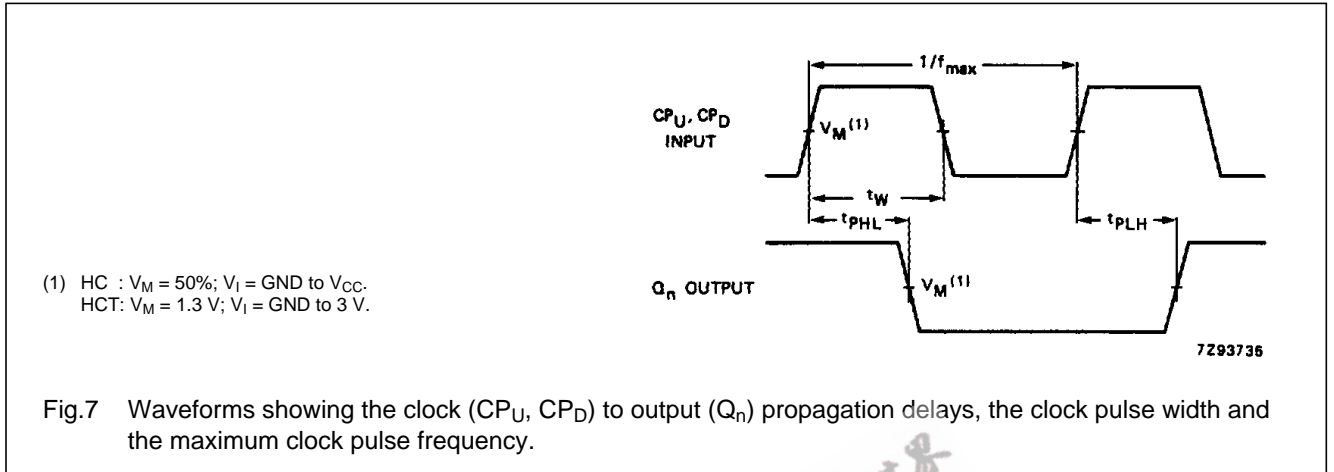

Fig.7 Waveforms showing the clock (CP_U, CP_D) to output (Q_n) propagation delays, the clock pulse width and the maximum clock pulse frequency.

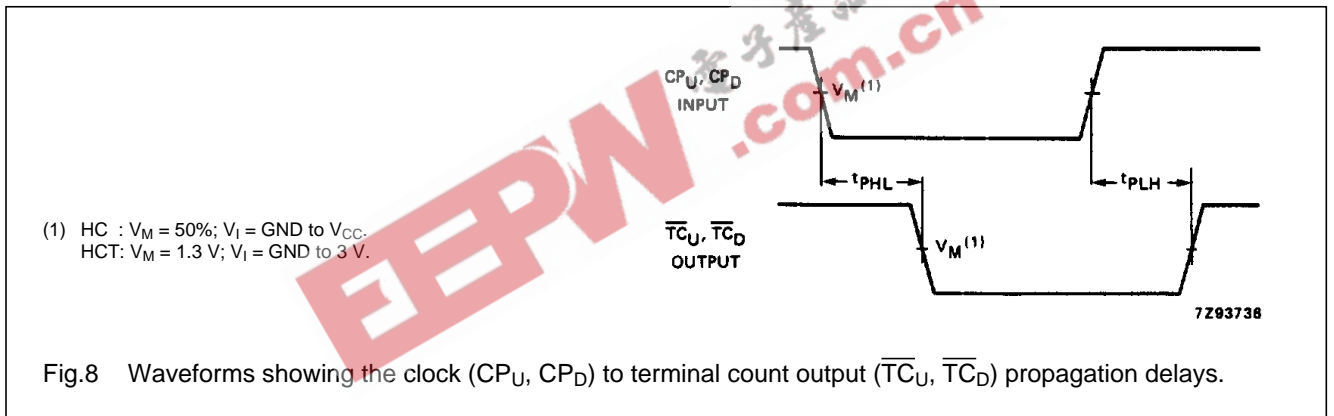

Fig.8 Waveforms showing the clock (CP_U, CP_D) to terminal count output ($\overline{TC}_U, \overline{TC}_D$) propagation delays.

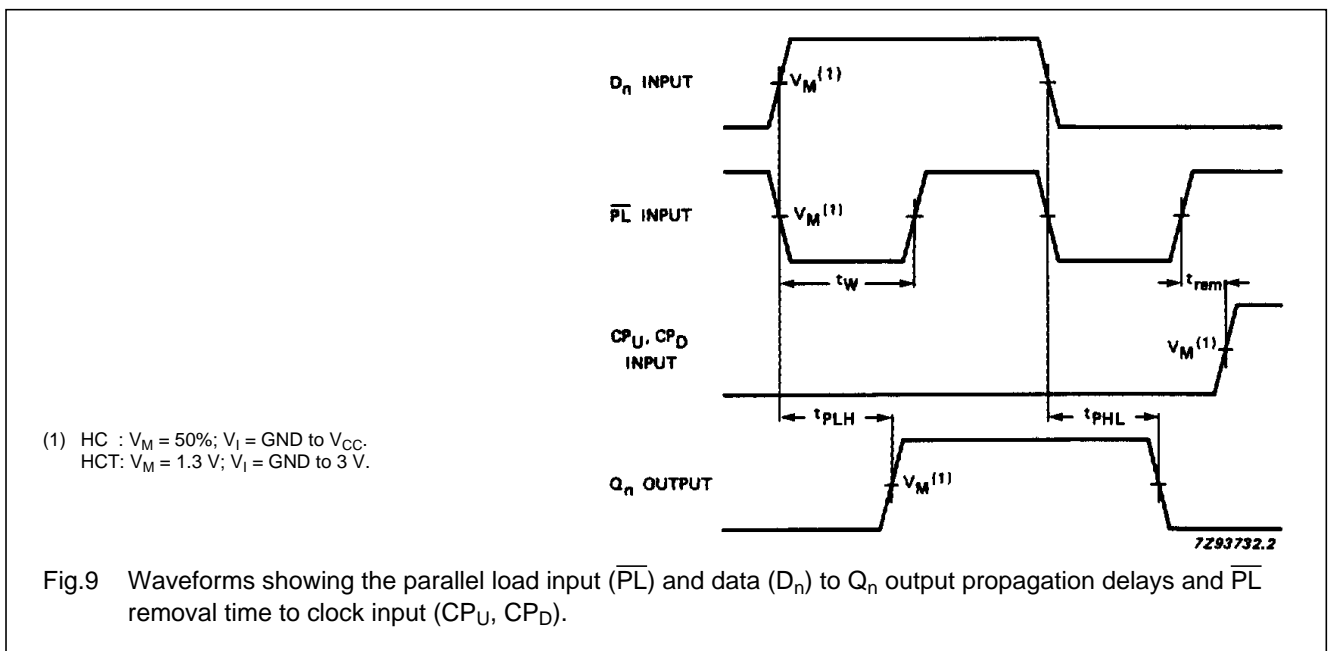
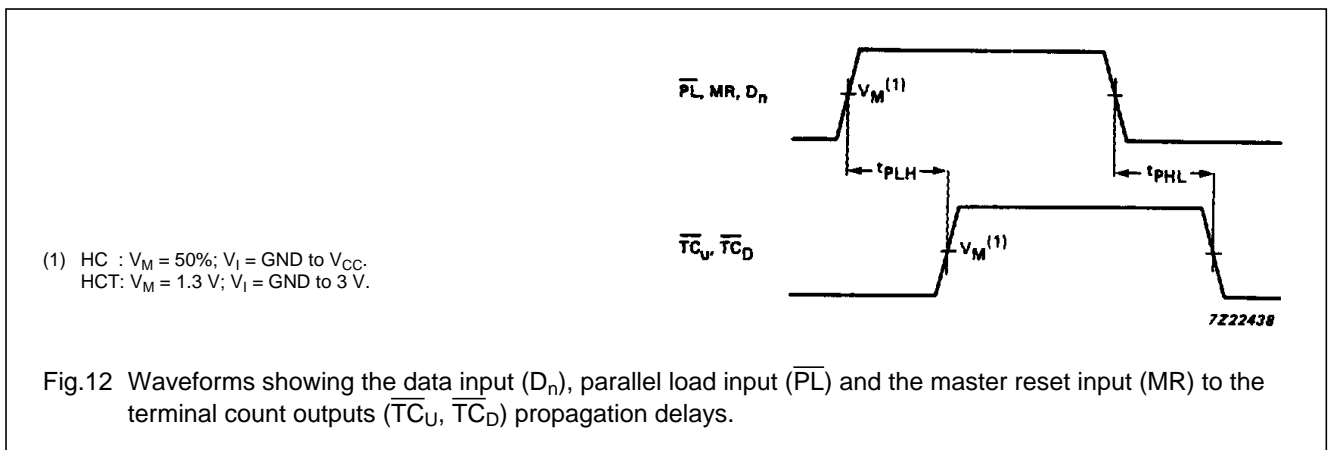
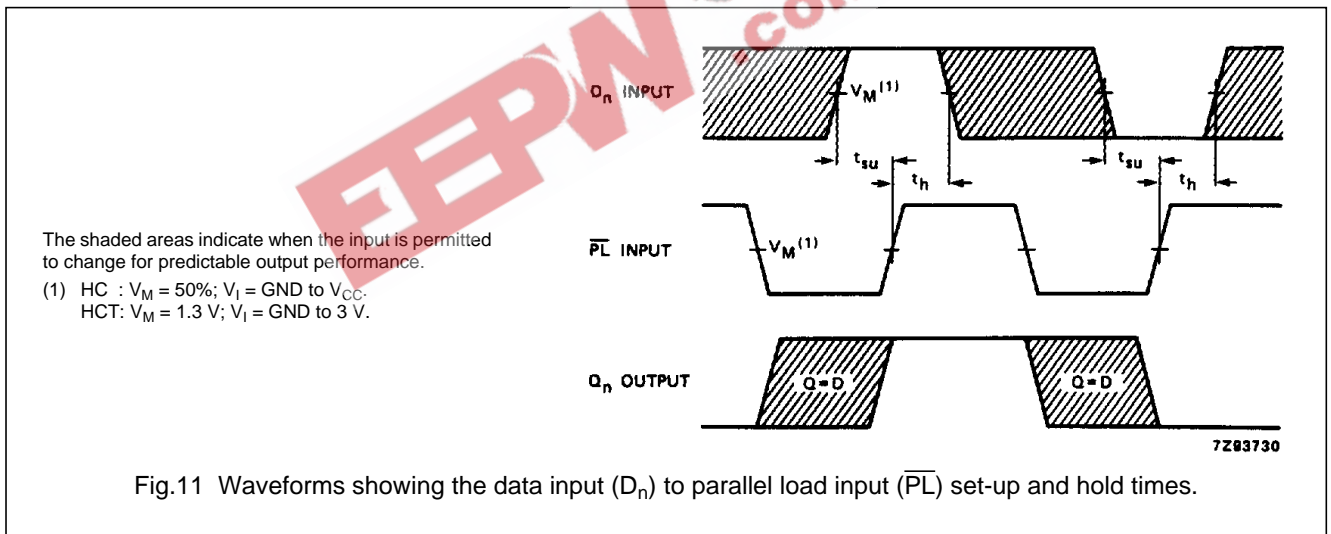
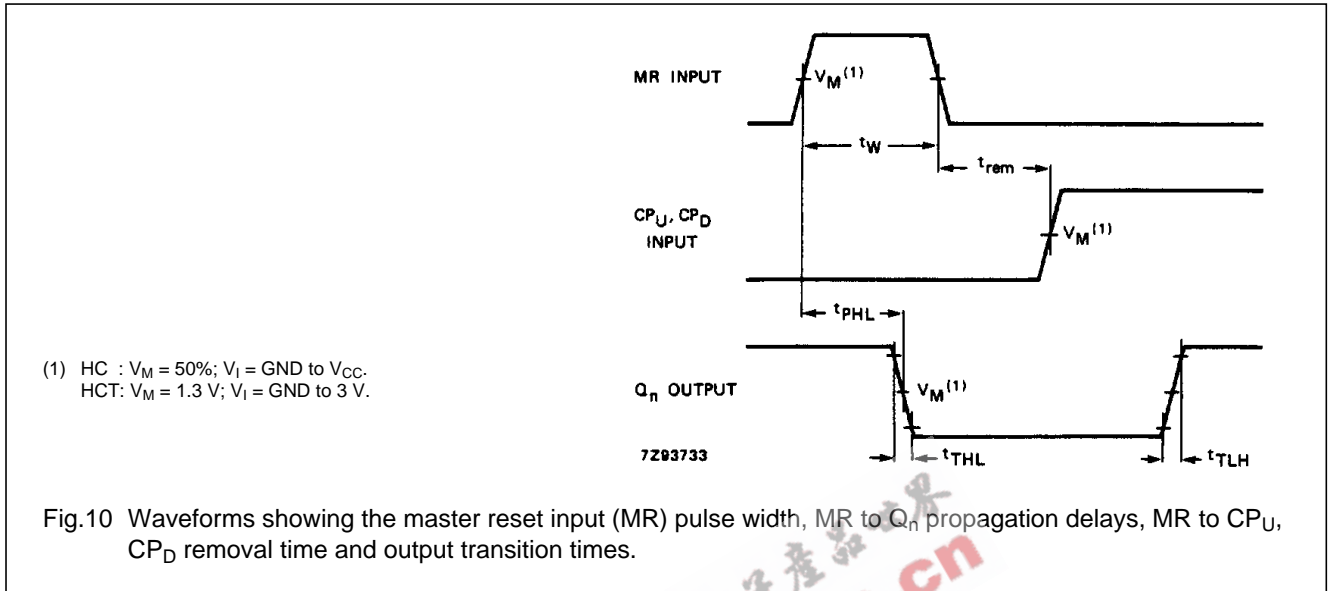

Fig.9 Waveforms showing the parallel load input (\overline{PL}) and data (D_n) to Q_n output propagation delays and \overline{PL} removal time to clock input (CP_U, CP_D).

Pre-settable synchronous BCD decade up/down counter

74HC/HCT192



Pre-settable synchronous BCD decade up/down counter

74HC/HCT192

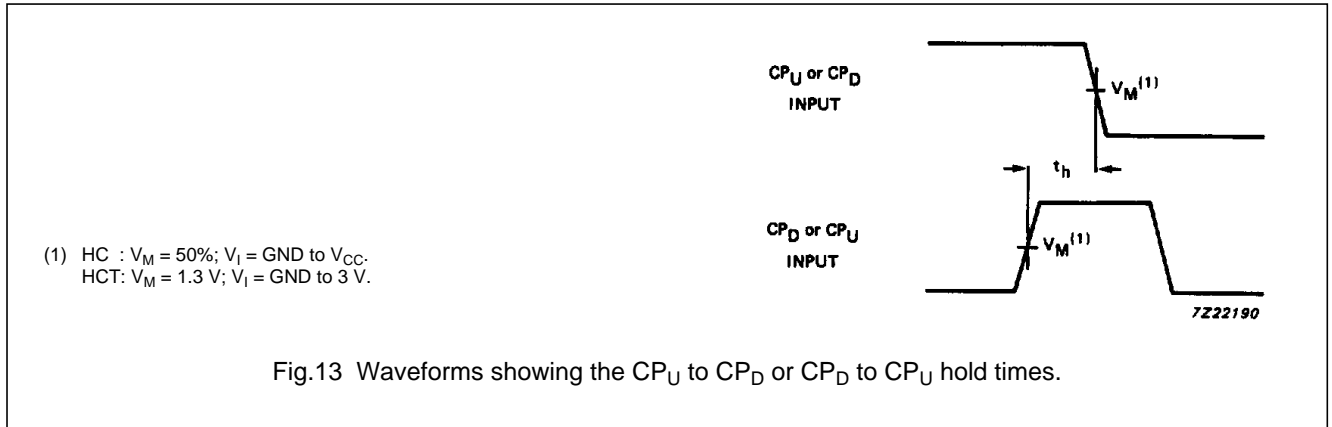

APPLICATION INFORMATION

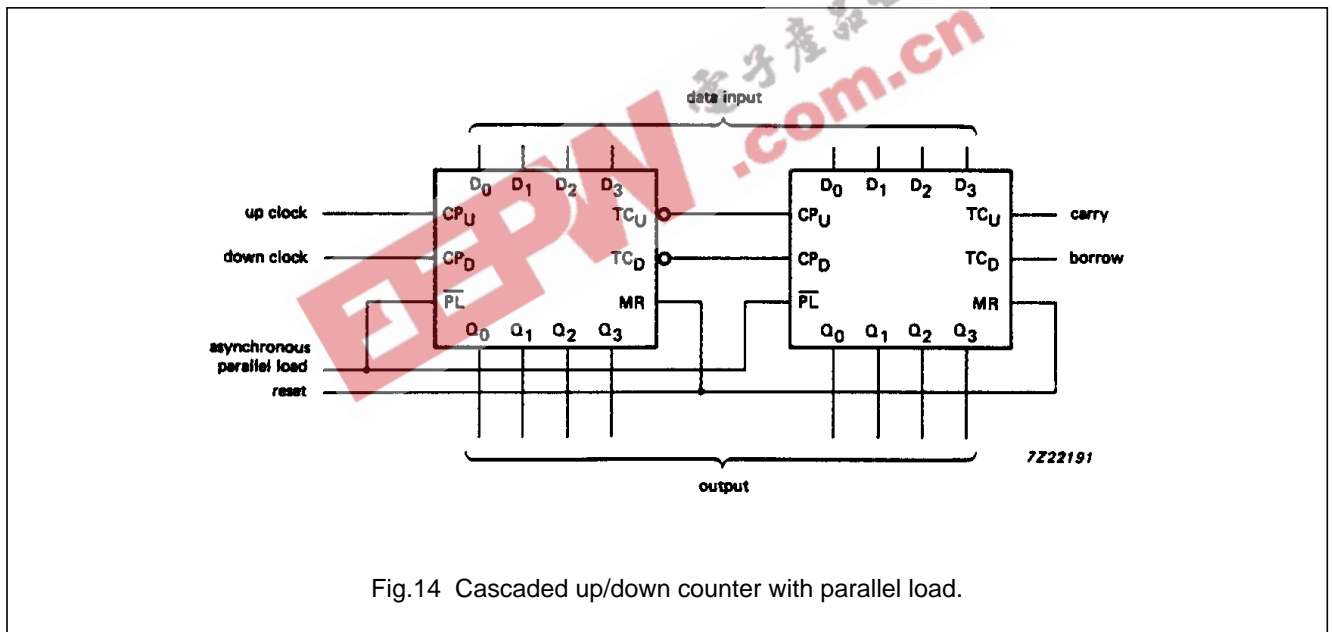

PACKAGE OUTLINES

See "74HC/HCT/HCU/HCMOS Logic Package Outlines".