

DM7446A, DM5447A/DM7447A BCD to 7-Segment Decoders/Drivers

General Description

The 46A and 47A feature active-low outputs designed for driving common-anode LEDs or incandescent indicators directly. All of the circuits have full ripple-blanking input/output controls and a lamp test input. Segment identification and resultant displays are shown on a following page. Display patterns for BCD input counts above nine are unique symbols to authenticate input conditions.

All of the circuits incorporate automatic leading and/or trailing-edge, zero-blanking control (RBI and RBO). Lamp test (LT) of these devices may be performed at any time when the BI/RBO node is at a high logic level. All types contain

an overriding blanking input (BI) which can be used to control the lamp intensity (by pulsing) or to inhibit the outputs.

Features

- All circuit types feature lamp intensity modulation capability
- Open-collector outputs drive indicators directly
- Lamp-test provision
- Leading/trailing zero suppression

Connection Diagram

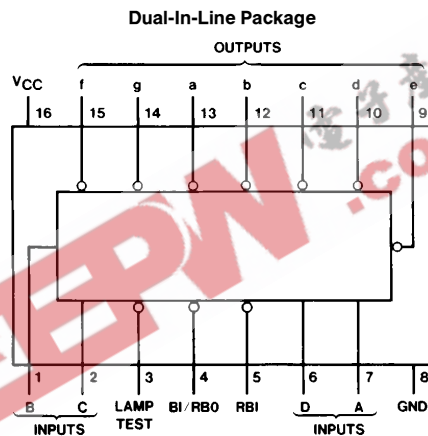

TL/F/6518-1

Order Number DM5447AJ, DM7446AN or DM7447AN
See NS Package Number J16A or N16E

Absolute Maximum Ratings (Note)

If Military/Aerospace specified devices are required, please contact the National Semiconductor Sales Office/Distributors for availability and specifications.

Supply Voltage	7V
Input Voltage	5.5V
Operating Free Air Temperature Range	
DM54	-55°C to +125°C
DM74	0°C to +70°C
Storage Temperature Range	-65°C to +150°C

Note: The "Absolute Maximum Ratings" are those values beyond which the safety of the device cannot be guaranteed. The device should not be operated at these limits. The parametric values defined in the "Electrical Characteristics" table are not guaranteed at the absolute maximum ratings. The "Recommended Operating Conditions" table will define the conditions for actual device operation.

Recommended Operating Conditions

Symbol	Parameter	DM7446A			Units
		Min	Nom	Max	
V _{CC}	Supply Voltage	4.75	5	5.25	V
V _{IH}	High Level Input Voltage	2			V
V _{IL}	Low Level Input Voltage			0.8	V
V _{OH}	High Level Output Voltage (a thru g)			30	V
I _{OH}	High Level Output Current (BI/RBO)			-0.2	μA
I _{OL}	Low Level Output Current (a thru g)			40	mA
I _{OL}	Low Level Output Current (BI/RBO)			8	mA
T _A	Free Air Operating Temperature	0		70	°C

'46A Electrical Characteristics

over recommended operating free air temperature range (unless otherwise noted)

Symbol	Parameter	Conditions	Min	Typ (Note 1)	Max	Units
V _I	Input Clamp Voltage	V _{CC} = Min, I _I = -12 mA			-1.5	V
V _{OH}	High Level Output Voltage (BI/RBO)	V _{CC} = Min I _{OH} = Max	2.4	3.7		V
I _{CEX}	High Level Output Current (a thru g)	V _{CC} = Max, V _O = 30V V _{IL} = Max, V _{IH} = Min			250	μA
V _{OL}	Low Level Output Voltage	V _{CC} = Min, I _{OL} = Max V _{IH} = Min, V _{IL} = Max		0.3	0.4	V
I _I	Input Current @ Max Input Voltage	V _{CC} = Max, V _I = 5.5V (Except BI/RBO)			1	mA
I _{IH}	High Level Input Current	V _{CC} = Max, V _I = 2.4V (Except BI/RBO)			40	μA
I _{IL}	Low Level Input Current	V _{CC} = Max V _I = 0.4V	BI/RBO		-4	mA
			Others		-1.6	
I _{OS}	Short Circuit Output Current	V _{CC} = Max (BI/RBO)			-4	mA
I _{CC}	Supply Current	V _{CC} = Max (Note 2)		60	103	mA

Note 1: All typicals are at V_{CC} = 5V, T_A = 25°C.

Note 2: I_{CC} is measured with all outputs open and all inputs at 4.5V.

'46A Switching Characteristics								
at $V_{CC} = 5V$ and $T_A = 25^\circ C$ (See Section 1 for Test Waveforms and Output Load)								
Symbol	Parameter	Conditions	Min	Max	Units			
t_{PLH}	Propagation Delay Time Low to High Level Output	$C_L = 15\text{ pF}$ $R_L = 120\Omega$		100	ns			
t_{PHL}	Propagation Delay Time High to Low Level Output			100	ns			
Recommended Operating Conditions								
Symbol	Parameter	DM5447A			DM7447A			Units
		Min	Nom	Max	Min	Nom	Max	
V_{CC}	Supply Voltage	4.5	5	5.5	4.75	5	5.25	V
V_{IH}	High Level Input Voltage	2			2			V
V_{IL}	Low Level Input Voltage			0.8			0.8	V
V_{OH}	High Level Output Voltage (a thru g)			15			15	V
I_{OH}	High Level Output Current (BI/RBO)			-0.2			-0.2	μA
I_{OL}	Low Level Output Current (a thru g)			40			40	mA
I_{OL}	Low Level Output Current (BI/RBO)			8			8	mA
T_A	Free Air Operating Temperature	-55		125	0		70	$^\circ C$
'47A Electrical Characteristics								
over recommended operating free air temperature range (unless otherwise noted)								
Symbol	Parameter	Conditions	Min	Typ (Note 1)	Max	Units		
V_I	Input Clamp Voltage	$V_{CC} = \text{Min}, I_I = -12\text{ mA}$			-1.5	V		
V_{OH}	High Level Output Voltage (BI/RBO)	$V_{CC} = \text{Min}$ $I_{OH} = \text{Max}$	2.4	3.7		V		
I_{CEX}	High Level Output Current (a thru g)	$V_{CC} = \text{Max}, V_O = 15V$ $V_{IL} = \text{Max}, V_{IH} = \text{Min}$			250	μA		
V_{OL}	Low Level Output Voltage	$V_{CC} = \text{Min}, I_{OL} = \text{Max}$ $V_{IH} = \text{Min}, V_{IL} = \text{Max}$		0.3	0.4	V		
I_I	Input Current @ Max Input Voltage	$V_{CC} = \text{Max}, V_I = 5.5V$			1	mA		
I_{IH}	High Level Input Current	$V_{CC} = \text{Max}, V_I = 2.4V$			40	μA		
I_{IL}	Low Level Input Current	$V_{CC} = \text{Max}$ $V_I = 0.4V$	BI/RBO		-4	mA		
			Others		-1.6			
I_{OS}	Short Circuit Output Current	$V_{CC} = \text{Max}$ (BI/RBO)			-4	mA		
I_{CC}	Supply Current	$V_{CC} = \text{Max}$ (Note 2)	DM54		60	85	mA	
			DM74		60	103		
Note 1: All typicals are at $V_{CC} = 5V, T_A = 25^\circ C$.								
Note 2: I_{CC} is measured with all outputs open and all inputs at 4.5V.								

'47A Switching Characteristics

at $V_{CC} = 5V$ and $T_A = 25^\circ C$ (See Section 1 for Test Waveforms and Output Load)

Symbol	Parameter	Conditions	Min	Max	Units
t_{PLH}	Propagation Delay Time Low to High Level Output	$C_L = 15\text{ pF}$ $R_L = 120\Omega$		100	ns
t_{PHL}	Propagation Delay Time High to Low Level Output			100	ns

Function Table

46A, 47A

Decimal or Function	Inputs						BI/RBO (Note 1)	Outputs							Note
	LT	RBI	D	C	B	A		a	b	c	d	e	f	g	
0	H	H	L	L	L	L	H	L	L	L	L	L	L	H	(2)
1	H	X	L	L	L	H	H	H	L	L	H	H	H	H	
2	H	X	L	L	H	L	H	L	L	H	L	L	H	L	
3	H	X	L	L	H	H	H	L	L	L	L	H	H	L	
4	H	X	L	H	L	L	H	H	L	L	H	H	L	L	
5	H	X	L	H	L	H	H	L	H	L	L	H	L	L	
6	H	X	L	H	H	L	H	H	H	L	L	L	L	L	
7	H	X	L	H	H	H	H	L	L	L	H	H	H	H	
8	H	X	H	L	L	L	H	L	L	L	L	L	L	L	
9	H	X	H	L	L	H	H	L	L	L	H	H	L	L	
10	H	X	H	L	H	L	H	H	H	H	L	L	H	L	
11	H	X	H	L	H	H	H	H	H	L	L	H	H	L	
12	H	X	H	H	L	L	H	H	L	H	H	H	L	L	
13	H	X	H	H	L	H	H	L	H	H	L	H	L	L	
14	H	X	H	H	H	L	H	H	H	H	L	L	L	L	
15	H	X	H	H	H	H	H	H	H	H	H	H	H	H	
BI	X	X	X	X	X	X	L	H	H	H	H	H	H	H	(3)
RBI	H	L	L	L	L	L	L	H	H	H	H	H	H	H	(4)
LT	L	X	X	X	X	X	H	L	L	L	L	L	L	L	(5)

Note 1: BI/RBO is a wire-AND logic serving as blanking input (BI) and/or ripple-blanking output (RBO).

Note 2: The blanking input (BI) must be open or held at a high logic level when output functions 0 through 15 are desired. The ripple-blanking input (RBI) must be open or high if blanking of a decimal zero is not desired.

Note 3: When a low logic level is applied directly to the blanking input (BI), all segment outputs are high regardless of the level of any other input.

Note 4: When ripple-blanking input (RBI) and inputs A, B, C, and D are at a low level with the lamp test input high, all segment outputs go H and the ripple-blanking output (RBO) goes to a low level (response condition).

Note 5: When the blanking input/ripple-blanking output (BI/RBO) is open or held high and a low is applied to the lamp-test input, all segment outputs are L.

H = High level, L = Low level, X = Don't Care

Logic Diagram

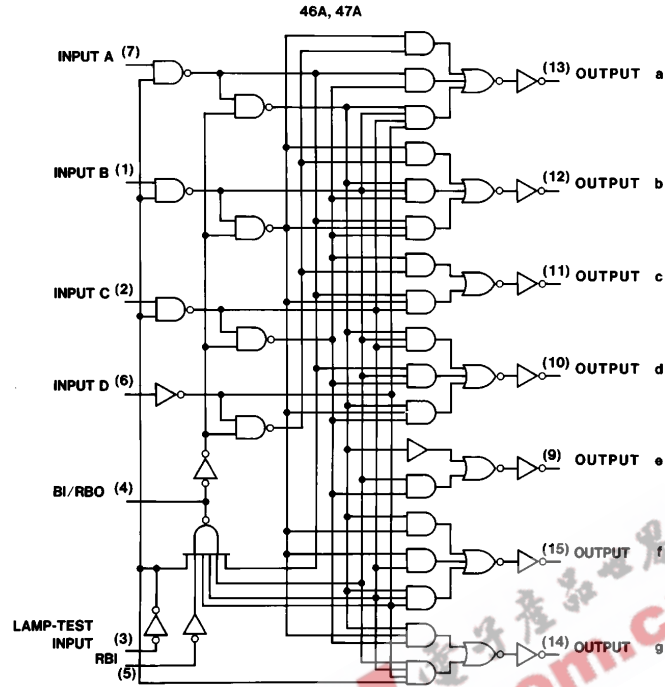

TL/F/6518-2

Physical Dimensions inches (millimeters)

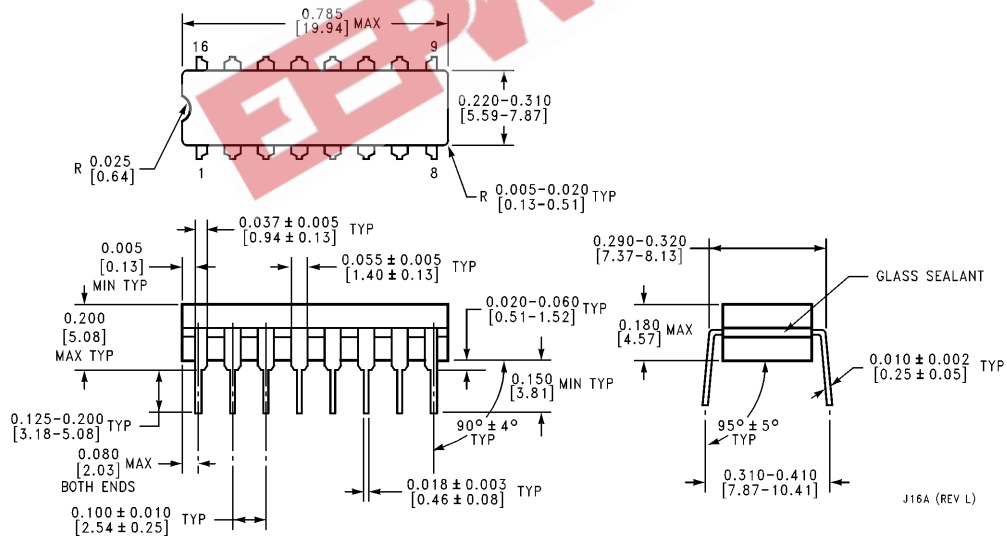

16-Lead Ceramic Dual-In-Line Package (J)
Order Number DM5447AJ
NS Package Number J16A

J16A (REV L)

Physical Dimensions inches (millimeters) (Continued)

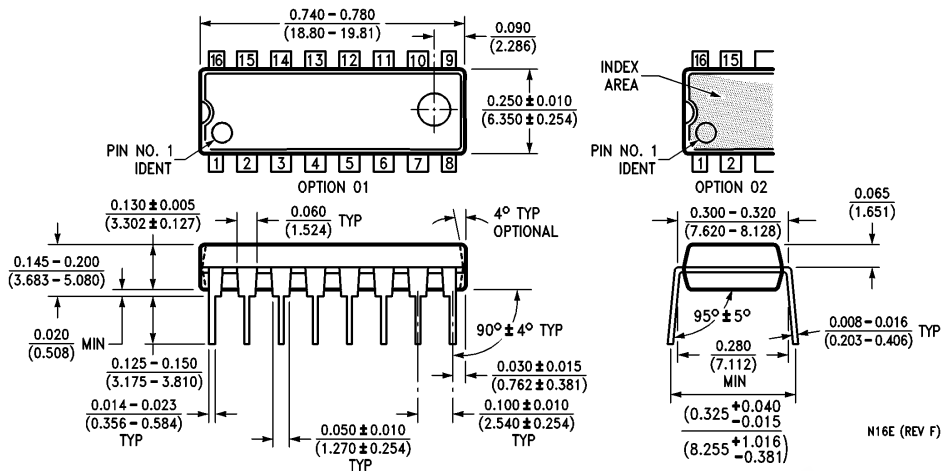

16-Lead Molded Dual-In-Line Package (N)
Order Number DM7446AN or DM7447AN
NS Package Number N16E



LIFE SUPPORT POLICY

NATIONAL'S PRODUCTS ARE NOT AUTHORIZED FOR USE AS CRITICAL COMPONENTS IN LIFE SUPPORT DEVICES OR SYSTEMS WITHOUT THE EXPRESS WRITTEN APPROVAL OF THE PRESIDENT OF NATIONAL SEMICONDUCTOR CORPORATION. As used herein:

1. Life support devices or systems are devices or systems which, (a) are intended for surgical implant into the body, or (b) support or sustain life, and whose failure to perform, when properly used in accordance with instructions for use provided in the labeling, can be reasonably expected to result in a significant injury to the user.
2. A critical component is any component of a life support device or system whose failure to perform can be reasonably expected to cause the failure of the life support device or system, or to affect its safety or effectiveness.



National Semiconductor Corporation
 1111 West Bardin Road
 Arlington, TX 76017
 Tel: 1(800) 272-9959
 Fax: 1(800) 737-7018

National Semiconductor Europe
 Fax: (+49) 0-180-530 85 86
 Email: cnjwge@levm2.nsc.com
 Deutsch Tel: (+49) 0-180-530 85 85
 English Tel: (+49) 0-180-532 78 32
 Français Tel: (+49) 0-180-532 93 58
 Italiano Tel: (+49) 0-180-534 16 80

National Semiconductor Hong Kong Ltd.
 13th Floor, Straight Block,
 Ocean Centre, 5 Canton Rd.
 Tsimshatsui, Kowloon
 Hong Kong
 Tel: (852) 2737-1600
 Fax: (852) 2736-9960

National Semiconductor Japan Ltd.
 Tel: 81-043-299-2309
 Fax: 81-043-299-2408