

FEATURES

- **Auto-Power-Up Feature Prevents Printer Errors When Printer Is Turned On, But No Valid Signal Is at A9–A13 Pins**
- **1.4-kΩ Pullup Resistors Integrated on All Open-Drain Outputs Eliminate the Need for Discrete Resistors**
- **Designed for IEEE Std 1284-I (Level-1 Type) and IEEE Std 1284-II (Level-2 Type) Electrical Specifications**
- **Flow-Through Architecture Optimizes PCB Layout**
- **I_{off} and Power-Up 3-State Support Hot Insertion**
- **Latch-Up Performance Exceeds 100 mA Per JESD 78, Class II**
- **ESD Protection**
 - ±4 kV – Human-Body Model
 - ±8 kV – IEC 61000-4-2, Contact Discharge (Connector Pins)
 - ±15 kV – IEC 61000-4-2, Air-Gap Discharge (Connector Pins)
 - ±15 kV – Human-Body Model (Connector Pins)

DGG OR DL PACKAGE (TOP VIEW)

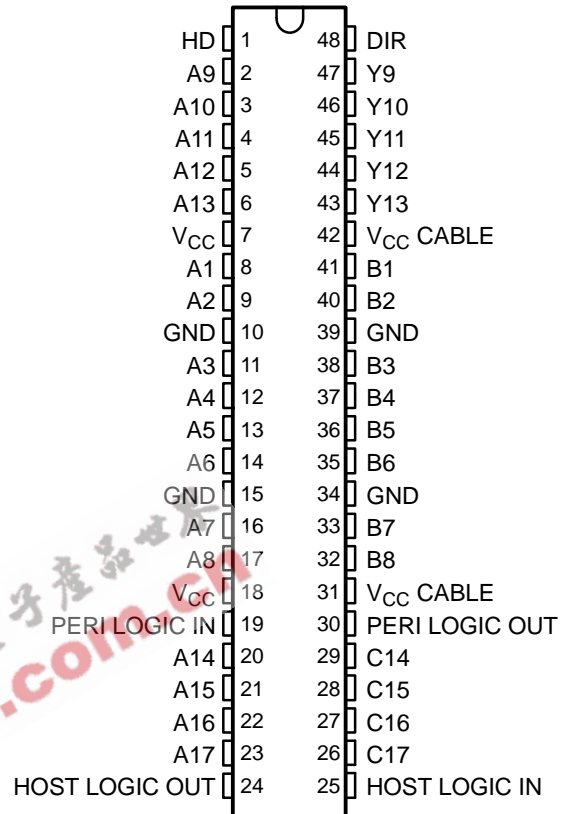

DESCRIPTION/ORDERING INFORMATION

The SN74LVCE161284 is designed for 3-V to 3.6-V V_{CC} operation. This device provides asynchronous two-way communication between data buses. The control-function implementation minimizes external timing requirements.

This device has eight bidirectional bits; data can flow in the A-to-B direction when the direction-control input (DIR) is high and in the B-to-A direction when DIR is low. This device also has five drivers that drive the cable side and four receivers. The SN74LVCE161284 has one receiver dedicated to the HOST LOGIC line and a driver to drive the PERI LOGIC line.

ORDERING INFORMATION

T _A	PACKAGE ⁽¹⁾		ORDERABLE PART NUMBER	TOP-SIDE MARKING
0°C to 70°C	SSOP – DL	Tube	SN74LVCE161284DL	LVCE161284
		Tape and reel	SN74LVCE161284DLR	
	TSSOP – DGG	Tape and reel	SN74LVCE161284DGGR	LVCE161284

(1) Package drawings, standard packing quantities, thermal data, symbolization, and PCB design guidelines are available at www.ti.com/sc/package.



Please be aware that an important notice concerning availability, standard warranty, and use in critical applications of Texas Instruments semiconductor products and disclaimers thereto appears at the end of this data sheet.

SN74LVCE161284
19-BIT IEEE STD 1284 TRANSLATION TRANSCEIVER
WITH ERROR-FREE POWER UP



SCES541 – JANUARY 2004 – REVISED MARCH 2005

DESCRIPTION/ORDERING INFORMATION (CONTINUED)

The output drive mode is determined by the high-drive (HD) control pin. When HD is high, the outputs are in a totem-pole configuration, and in an open-drain configuration when HD is low. This meets the drive requirements as specified in the IEEE Std 1284-I (level-1 type) and IEEE Std 1284-II (level-2 type) parallel peripheral-interface specifications. Except for HOST LOGIC IN and peripheral logic out (PERI LOGIC OUT), all cable-side pins have a 1.4-k Ω integrated pullup resistor. The pullup resistor is switched off if the associated output driver is in the low state or if the output voltage is above V_{CC} CABLE. If V_{CC} CABLE is off, PERI LOGIC OUT is set to low.

The device has two supply voltages. V_{CC} is designed for 3-V to 3.6-V operation. V_{CC} CABLE supplies the inputs and output buffers of the cable side only and is designed for 3-V to 3.6-V and for 4.7-V to 5.5-V operation. Even when V_{CC} CABLE is 3 V to 3.6 V, the cable-side I/O pins are 5-V tolerant.

The Y outputs (Y9–Y13) stay in the high state after power on until an associated input (A9–A13) goes high. When an associated input goes high, all Y outputs are activated, and noninverting signals of the associated inputs are driven through Y outputs. This special feature prevents printer-system errors caused by deasserting the BUSY signal in the cable at power on.

FUNCTION TABLE

INPUTS		OUTPUT	MODE
DIR	HD		
L	L	Open drain	A9–A13 to Y9–Y13 and PERI LOGIC IN to PERI LOGIC OUT
		Totem pole	B1–B8 to A1–A8 and C14–C17 to A14–A17
L	H	Totem pole	B1–B8 to A1–A8, A9–A13 to Y9–Y13, PERI LOGIC IN to PERI LOGIC OUT, and C14–C17 to A14–A17
H	L	Open drain	A1–A8 to B1–B8, A9–A13 to Y9–Y13, and PERI LOGIC IN to PERI LOGIC OUT
		Totem pole	C14–C17 to A14–A17
H	H	Totem pole	A1–A8 to B1–B8, A9–A13 to Y9–Y13, C14–C17 to A14–A17, and PERI LOGIC IN to PERI LOGIC OUT

LOGIC DIAGRAM

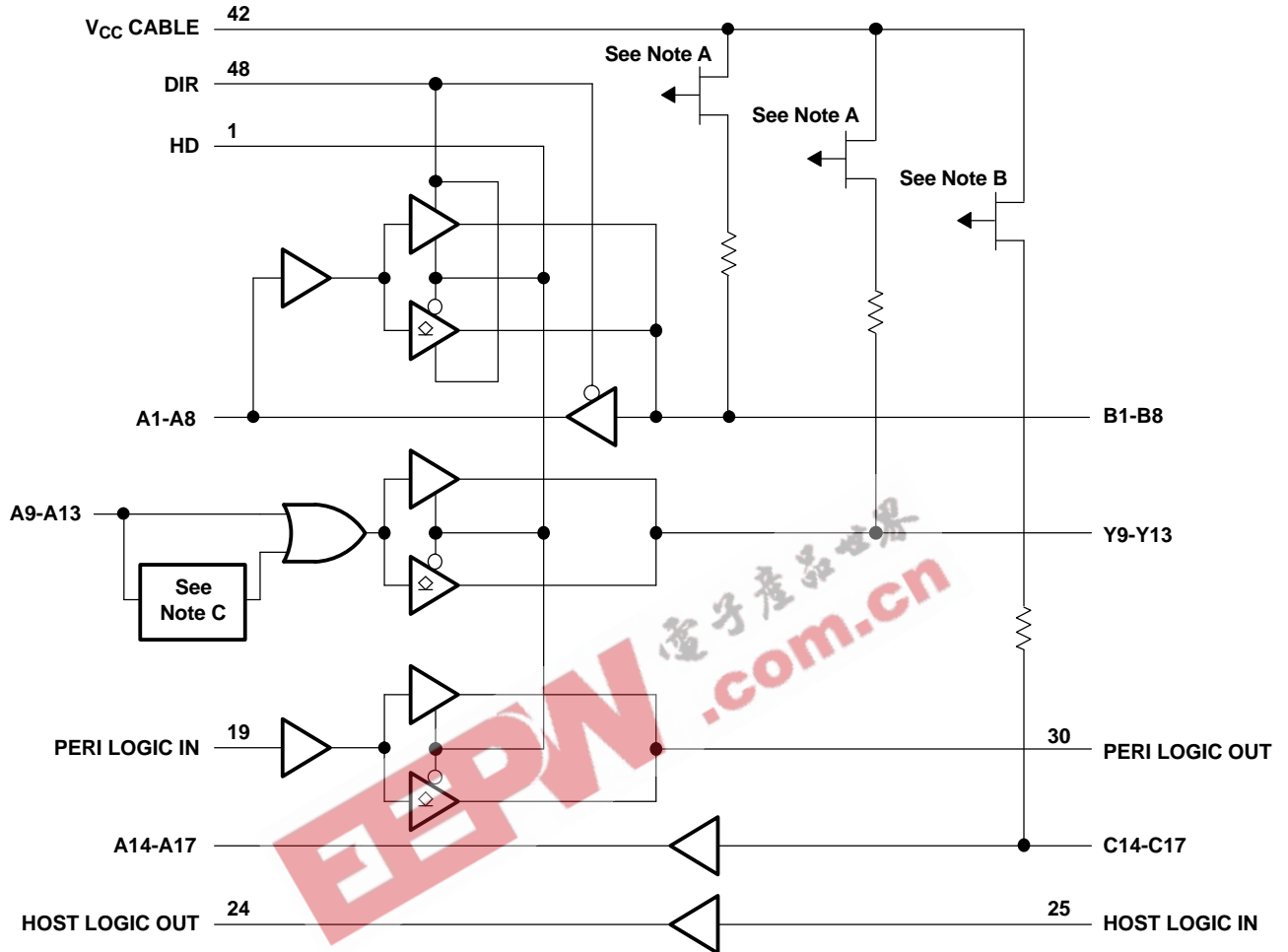

- NOTES:
- A. The PMOS transistors prevent backdriving current from the signal pins to V_{CC} CABLE when V_{CC} CABLE is open or at GND. The PMOS transistor is turned off when the associated driver is in the low state.
 - B. The PMOS transistor prevents backdriving current from the signal pins to V_{CC} CABLE when V_{CC} CABLE is open or at GND.
 - C. Active input detection circuit forces Y9-Y13 to the high state after power-on, until one of the A9-A13 goes high (see Figure 1).

SN74LVCE161284
19-BIT IEEE STD 1284 TRANSLATION TRANSCEIVER
WITH ERROR-FREE POWER UP

SCES541 – JANUARY 2004 – REVISED MARCH 2005

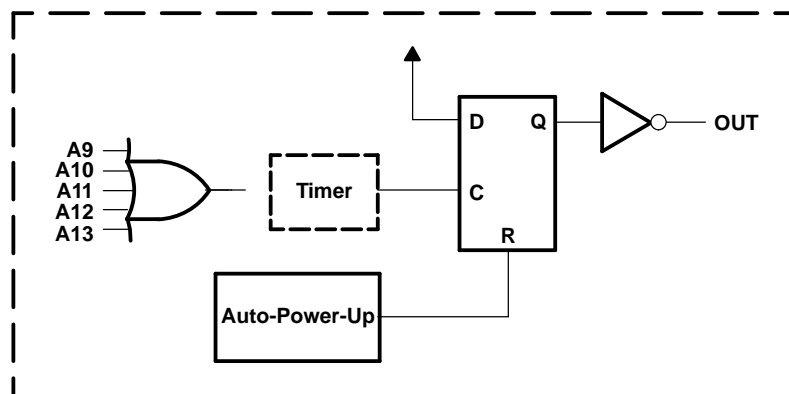

Active Input Detection Circuit

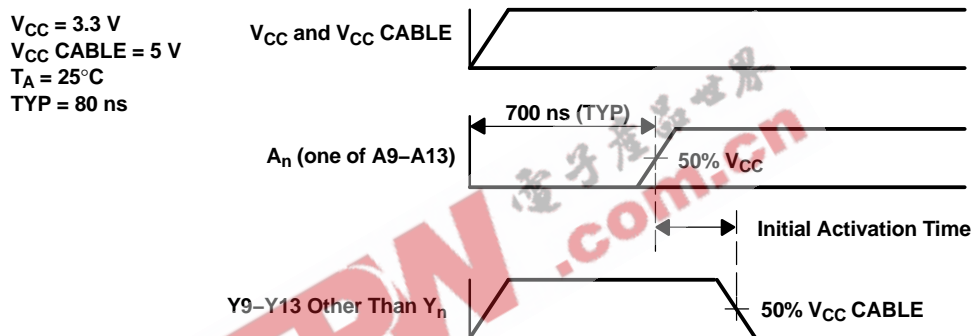

NOTE A: One of A9–A13 is switched as shown above, and the other four inputs are forced to low state.

Figure 1. Error-Free Circuit Timing

Absolute Maximum Ratings⁽¹⁾

over operating free-air temperature range (unless otherwise noted)

		MIN	MAX	UNIT
V _{CC CABLE}	Supply voltage range	-0.5	7	V
V _{CC}	Supply voltage range	-0.5	4.6	V
V _I , V _O	Input and output voltage range	Cable side ⁽²⁾⁽³⁾		V
		-2	7	
		Peripheral side ⁽²⁾		V
		-0.5	V _{CC} + 0.5	
I _{IK}	Input clamp current	V _I < 0		-20 mA
I _{OK}	Output clamp current	V _O < 0		-50 mA
I _O	Continuous output current	Except PERI LOGIC OUT		±50 mA
		PERI LOGIC OUT		±100 mA
	Continuous current through each V _{CC} or GND			±200 mA
I _{SK}	Output high sink current	V _O = 5.5 V and V _{CC CABLE} = 3 V		65 mA
θ _{JA}	Package thermal impedance ⁽⁴⁾	DGG package		70 °C/W
		DL package		63 °C/W
T _{stg}	Storage temperature range	-65	150	°C

- (1) Stresses beyond those listed under "absolute maximum ratings" may cause permanent damage to the device. These are stress ratings only, and functional operation of the device at these or any other conditions beyond those indicated under "recommended operating conditions" is not implied. Exposure to absolute-maximum-rated conditions for extended periods may affect device reliability.
- (2) The input and output voltage ratings may be exceeded if the input and output current ratings are observed.
- (3) The ac input-voltage pulse duration is limited to 40 ns if the amplitude is greater than -0.5 V.
- (4) The package thermal impedance is calculated in accordance with JESD 51-7.

Recommended Operating Conditions⁽¹⁾

		MIN	MAX	UNIT
V _{CC CABLE}	Supply voltage for the cable side, V _{CC CABLE} ≥ V _{CC}	3	5.5	V
V _{CC}	Supply voltage	3	3.6	V
V _{IH}	High-level input voltage	A, B, DIR, and HD		V
		C14-C17		
		HOST LOGIC IN		
		PERI LOGIC IN		
V _{IL}	Low-level input voltage	A, B, DIR, and HD		V
		C14-C17		
		HOST LOGIC IN		
		PERI LOGIC IN		
V _I	Input voltage	Peripheral side		V
		0	V _{CC}	
V _O	Open-drain output voltage	Cable side		V
		0	5.5	
I _{OH}	High-level output current	HD low		mA
		HD high, B and Y outputs		
		A outputs and HOST LOGIC OUT		
		PERI LOGIC OUT		
I _{OL}	Low-level output current	B and Y outputs		mA
		A outputs and HOST LOGIC OUT		
		PERI LOGIC OUT		
T _A	Operating free-air temperature	0	70	°C

- (1) All unused inputs of the device must be held at V_{CC} or GND to ensure proper device operation. Refer to the TI application report, *Implications of Slow or Floating CMOS Inputs*, literature number SCBA004.

SN74LVCE161284

19-BIT IEEE STD 1284 TRANSLATION TRANSCEIVER WITH ERROR-FREE POWER UP

SCES541–JANUARY 2004–REVISED MARCH 2005

Electrical Characteristics

over recommended operating free-air temperature range (unless otherwise noted)

PARAMETER		TEST CONDITIONS	V _{CC}	V _{CC} CABLE	MIN	TYP ⁽¹⁾	MAX	UNIT	
ΔV _t Hysteresis (V _{T+} – V _{T-})	All inputs except the C inputs and HOST LOGIC IN		3.3 V	5 V	0.4		V		
	HOST LOGIC IN				0.2				
	C inputs				0.8				
V _{OH}	HD high, B and Y outputs	I _{OH} = –14 mA	3 V	3 V	2.23		V		
			3.3 V	4.7 V	2.4				
	HD high, A outputs, and HOST LOGIC OUT	I _{OH} = –4 mA	3 V	3 V	2.4				
		I _{OH} = –50 μA			2.8				
	PERI LOGIC OUT	I _{OH} = –0.5 mA	3.15 V	3.15 V	3.1				
		3.3 V	4.7 V	4.5					
V _{OL}	B and Y outputs	I _{OL} = 14 mA	3 V	3 V			0.77	V	
	A outputs and HOST LOGIC OUT	I _{OL} = 50 μA					0.2		
		I _{OL} = 4 mA					0.4		
	PERI LOGIC OUT	I _{OL} = 84 mA					0.9		
I _I	C inputs	V _I = V _{CC}	3.6 V	3.6 V			50	μA	
		V _I = GND (pullup resistors)					–3.5		mA
	All inputs except B or C inputs	V _I = V _{CC} or GND					±1	μA	
I _{OZ}	A1–A8	V _O = V _{CC} or GND	3.6 V	3.6 V	5.5 V		±20	μA	
	B outputs	V _O = V _{CC} CABLE					50		
					V _O = GND (pullup resistors)			–3.5	mA
	Open-drain Y outputs	V _O = GND (pullup resistors)					–3.5		
I _{OZPU}	B and Y outputs	V _O = 5.5 V	0 to 1.5 V ⁽²⁾	0 to 1.5 V ⁽²⁾			350	μA	
		V _O = GND					–5		mA
I _{OZPD}	B and Y outputs	V _O = 5.5 V	0 to 1.5 V ⁽²⁾	0 to 1.5 V ⁽²⁾			350	μA	
		V _O = GND					–5		mA
I _{off}	Power-down input leakage, except A1–A8 or B1–B8 inputs	V _I or V _O = 0 to 3.6 V	0	0			100	μA	
	Power-down output leakage, B1–B8 and Y9–Y13 outputs	V _I or V _O = 0 to 5.5 V					100		
I _{CC}		V _I = GND (12 × pullup)	3.6 V	3.6 V			45	mA	
					3.6 V				70
		V _I = V _{CC} , I _O = 0							0.8
Z _O	B1–B8, Y9–Y13	I _{OH} = –35 mA	3.3 V	3.3 V	36		Ω		
R pullup	B1–B8, Y9–Y13, C14–C17	V _O = 0 V (in high-impedance state)	3.3 V	3.3 V	1.15	1.65		kΩ	
C _i	A9–A13, DIR, HD, PERI LOGIC IN	V _I = V _{CC} or GND	3.3 V	5 V	6.5		pF		
	HOST LOGIC IN				4				
C _{io}	A1–A8	V _O = V _{CC} or GND	3.3 V	5 V	8		pF		
	B1–B8				13				

(1) Typical values are measured at T_A = 25°C.

(2) Connect the V_{CC} pin to the V_{CC} CABLE pin.

Switching Characteristics

over recommended ranges of supply voltage and operating free-air temperature (unless otherwise noted) (see Figure 2 and Figure 3)

PARAMETER		FROM (INPUT)	TO (OUTPUT)	MIN	TYP ⁽¹⁾	MAX	UNIT
t_{PLH}	Totem pole	A1–A8	B1–B8	2		30	ns
t_{PHL}				2	30		
t_{PLH}	Totem pole	A9–A13	Y9–Y13	2		30	ns
t_{PHL}				2	30		
t_{PLH}	Totem pole	B1–B8	A1–A8	2		12	ns
t_{PHL}				2	12		
t_{PLH}	Totem pole	C14–C17	A14–A17	2		14	ns
t_{PHL}				2	14		
t_{PLH}	Totem pole	PERI LOGIC IN	PERI LOGIC OUT	2		16	ns
t_{PHL}				2	16		
t_{PLH}	Totem pole	HOST LOGIC IN	HOST LOGIC OUT	1		18	ns
t_{PHL}				1	18		
t_{slew}	Totem pole	B1–B8 and Y9–Y13 outputs		0.05		0.4	V/ns
t_{PZH}		HD	B1–B8, Y9–Y13, and PERI LOGIC OUT	2		30	ns
t_{PHZ}				2	25		
$t_{en}-t_{dis}$		DIR	A1–A8	2		25	ns
t_{PHZ}		DIR	B1–B8	2		25	ns
t_{PLZ}				2	25		
t_r, t_f	Open drain	A1–A13	B1–B8 or Y9–Y13	1		120	ns
$t_{sk(o)}$ ⁽²⁾		A1–A8 or B1–B8	B1–B8 or A1–A8		3	10	ns

(1) Typical values are measured at $V_{CC} = 3.3\text{ V}$, $V_{CC\text{ CABLE}} = 5\text{ V}$, and $T_A = 25^\circ\text{C}$.

(2) Skew is measured at $1/2 (V_{OH} + V_{OL})$ for signals switching in the same direction.

Table 1. ESD Protection

PIN	TEST CONDITIONS	TYP	UNIT
B1–B8, Y9–Y13, PERI LOGIC OUT, C14–C17, HOST LOGIC IN	HBM	± 15	kV
	Contact discharge, IEC 61000-4-2	± 8	
	Air-gap discharge, IEC 61000-4-2	± 15	
DIR, HD, A1–A8, A9–A13, PERI LOGIC IN, A14–A17, HOST LOGIC OUT	HBM	± 4	kV

Operating Characteristics

V_{CC} and $V_{CC\text{ CABLE}} = 3.3\text{ V}$, $C_L = 0$, $f = 10\text{ MHz}$, $T_A = 25^\circ\text{C}$

PARAMETER		FROM (INPUT)	TO (OUTPUT)	TYP	UNIT
C_{pd}	Power dissipation capacitance	A	B	15	pF
		A	Y	6	
		PERI LOGIC IN	PERI LOGIC OUT	10	
		B	A	33	
		C	A	29	
		HOST LOGIC IN	HOST LOGIC OUT	29	

PARAMETER MEASUREMENT INFORMATION

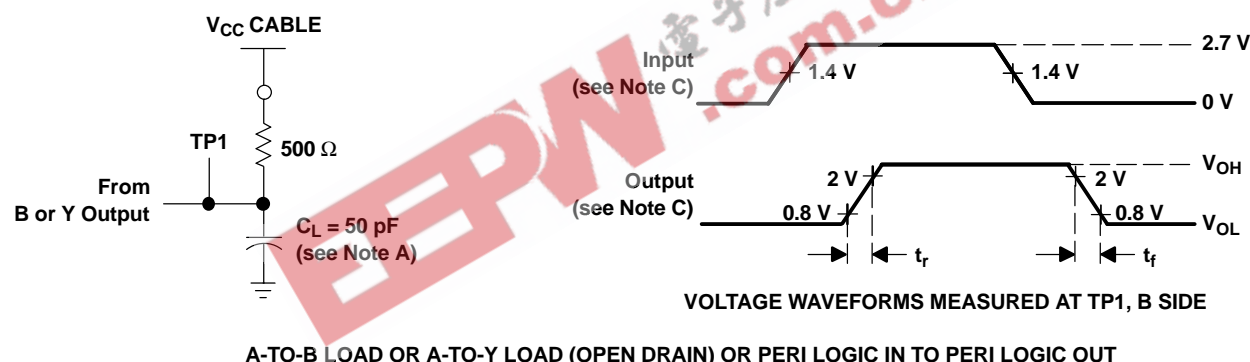
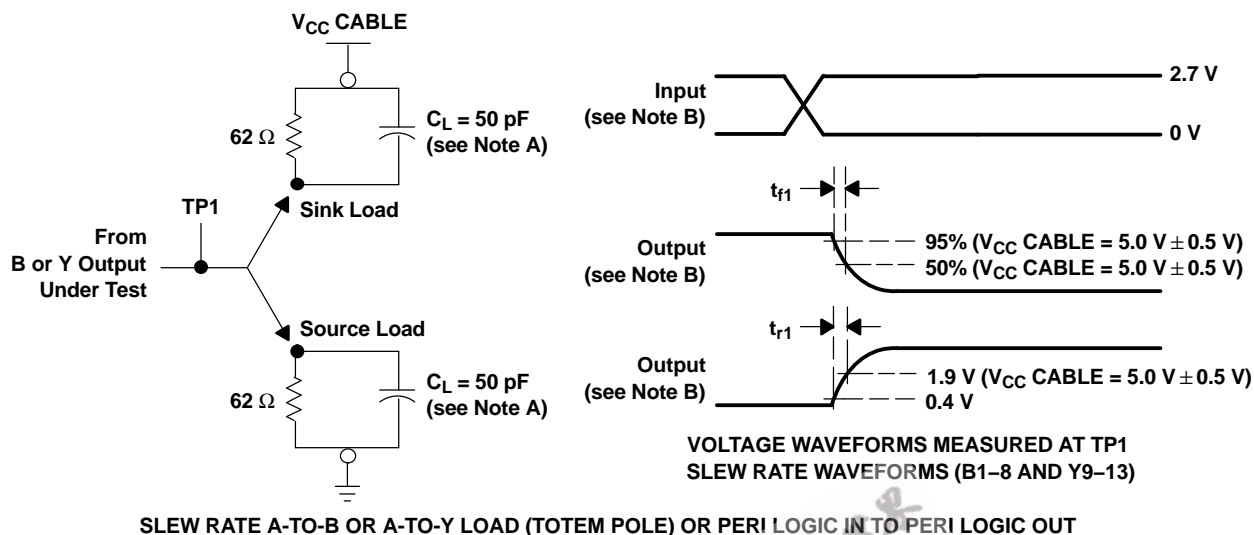

- NOTES: A. C_L includes probe and jig capacitance.
B. When V_{CC} CABLE is 3.3 V \pm 0.3 V, slew rate is measured between 0.4 V and 0.9 V for the rising edge and between 2.4 V and 1.9 V for the falling edge. When V_{CC} CABLE is 5 V \pm 0.5 V, slew rate is measured between 0.4 V and 1.9 V for the rising edge and between 95% V_{CC} CABLE and 50% V_{CC} CABLE for the falling edge.

$$t_{\text{slew fall}} = V_{CC} \left(\frac{95\% - 50\%}{t_{r1}} \right) \quad t_{\text{slew rise}} = \left(\frac{1.9\ \text{V} - 0.4\ \text{V}}{t_{r1}} \right)$$

- C. Input rise (t_r) and fall (t_f) times are 3 ns. Rise and fall times (open drain) are <120 ns.
D. The outputs are measured one at a time, with one transition per measurement.
E. t_{PLZ} and t_{PHZ} are the same as t_{dis} .
F. t_{PZL} and t_{PZH} are the same as t_{en} .
G. t_{PLH} and t_{PHL} are the same as t_{pd} .

Figure 2. Load Circuits and Voltage Waveforms

PARAMETER MEASUREMENT INFORMATION

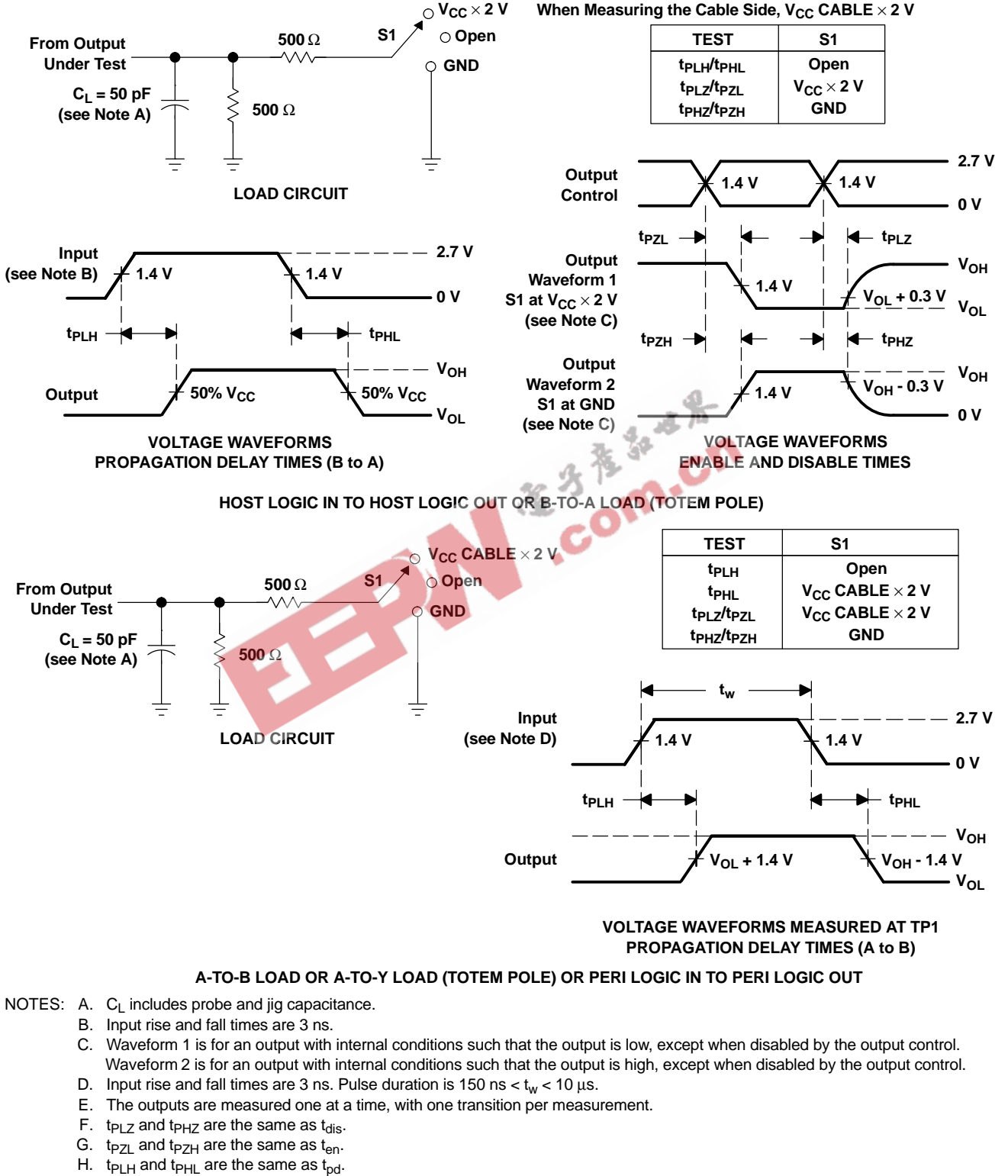

Figure 3. Load Circuits and Voltage Waveforms

PACKAGING INFORMATION

Orderable Device	Status ⁽¹⁾	Package Type	Package Drawing	Pins	Package Qty	Eco Plan ⁽²⁾	Lead/Ball Finish	MSL Peak Temp ⁽³⁾
74LVCE161284DGGRE4	ACTIVE	TSSOP	DGG	48	2000	Green (RoHS & no Sb/Br)	CU NIPDAU	Level-1-260C-UNLIM
74LVCE161284DGGRG4	ACTIVE	TSSOP	DGG	48	2000	Green (RoHS & no Sb/Br)	CU NIPDAU	Level-1-260C-UNLIM
74LVCE161284DLG4	ACTIVE	SSOP	DL	48	25	Green (RoHS & no Sb/Br)	CU NIPDAU	Level-1-260C-UNLIM
74LVCE161284DLRG4	ACTIVE	SSOP	DL	48	1000	Green (RoHS & no Sb/Br)	CU NIPDAU	Level-1-260C-UNLIM
74LVCE161284VRE4	ACTIVE	TVSOP	DGV	48	2000	Green (RoHS & no Sb/Br)	CU NIPDAU	Level-1-260C-UNLIM
74LVCE161284VRG4	ACTIVE	TVSOP	DGV	48	2000	Green (RoHS & no Sb/Br)	CU NIPDAU	Level-1-260C-UNLIM
SN74LVCE161284DGGR	ACTIVE	TSSOP	DGG	48	2000	Green (RoHS & no Sb/Br)	CU NIPDAU	Level-1-260C-UNLIM
SN74LVCE161284DL	ACTIVE	SSOP	DL	48	25	Green (RoHS & no Sb/Br)	CU NIPDAU	Level-1-260C-UNLIM
SN74LVCE161284DLR	ACTIVE	SSOP	DL	48	1000	Green (RoHS & no Sb/Br)	CU NIPDAU	Level-1-260C-UNLIM
SN74LVCE161284VR	ACTIVE	TVSOP	DGV	48	2000	Green (RoHS & no Sb/Br)	CU NIPDAU	Level-1-260C-UNLIM

⁽¹⁾ The marketing status values are defined as follows:

ACTIVE: Product device recommended for new designs.

LIFEBUY: TI has announced that the device will be discontinued, and a lifetime-buy period is in effect.

NRND: Not recommended for new designs. Device is in production to support existing customers, but TI does not recommend using this part in a new design.

PREVIEW: Device has been announced but is not in production. Samples may or may not be available.

OBSOLETE: TI has discontinued the production of the device.

⁽²⁾ Eco Plan - The planned eco-friendly classification: Pb-Free (RoHS), Pb-Free (RoHS Exempt), or Green (RoHS & no Sb/Br) - please check <http://www.ti.com/productcontent> for the latest availability information and additional product content details.

TBD: The Pb-Free/Green conversion plan has not been defined.

Pb-Free (RoHS): TI's terms "Lead-Free" or "Pb-Free" mean semiconductor products that are compatible with the current RoHS requirements for all 6 substances, including the requirement that lead not exceed 0.1% by weight in homogeneous materials. Where designed to be soldered at high temperatures, TI Pb-Free products are suitable for use in specified lead-free processes.

Pb-Free (RoHS Exempt): This component has a RoHS exemption for either 1) lead-based flip-chip solder bumps used between the die and package, or 2) lead-based die adhesive used between the die and leadframe. The component is otherwise considered Pb-Free (RoHS compatible) as defined above.

Green (RoHS & no Sb/Br): TI defines "Green" to mean Pb-Free (RoHS compatible), and free of Bromine (Br) and Antimony (Sb) based flame retardants (Br or Sb do not exceed 0.1% by weight in homogeneous material)

⁽³⁾ MSL, Peak Temp. -- The Moisture Sensitivity Level rating according to the JEDEC industry standard classifications, and peak solder temperature.

Important Information and Disclaimer: The information provided on this page represents TI's knowledge and belief as of the date that it is provided. TI bases its knowledge and belief on information provided by third parties, and makes no representation or warranty as to the accuracy of such information. Efforts are underway to better integrate information from third parties. TI has taken and continues to take reasonable steps to provide representative and accurate information but may not have conducted destructive testing or chemical analysis on incoming materials and chemicals. TI and TI suppliers consider certain information to be proprietary, and thus CAS numbers and other limited information may not be available for release.

In no event shall TI's liability arising out of such information exceed the total purchase price of the TI part(s) at issue in this document sold by TI to Customer on an annual basis.

TAPE AND REEL BOX INFORMATION

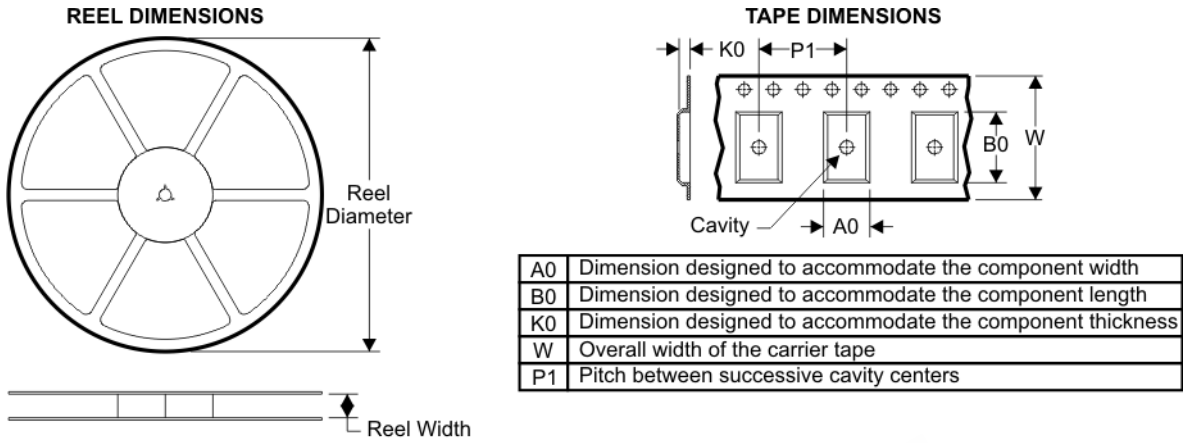

QUADRANT ASSIGNMENTS FOR PIN 1 ORIENTATION IN TAPE

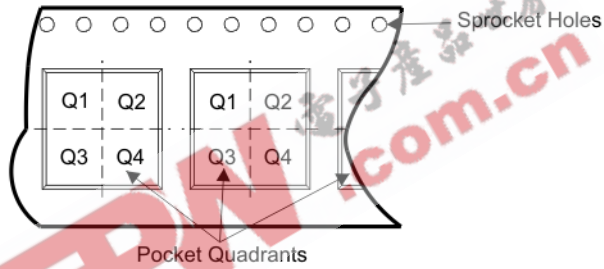

Device	Package	Pins	Site	Reel Diameter (mm)	Reel Width (mm)	A0 (mm)	B0 (mm)	K0 (mm)	P1 (mm)	W (mm)	Pin1 Quadrant
SN74LVCE161284DGGR	DGG	48	SITE 41	330	24	8.6	15.8	1.8	12	24	Q1
SN74LVCE161284DLR	DL	48	SITE 41	330	32	11.35	16.2	3.1	16	32	Q1
SN74LVCE161284VR	DGV	48	SITE 41	330	24	6.8	10.1	1.6	12	24	Q1

TAPE AND REEL BOX DIMENSIONS

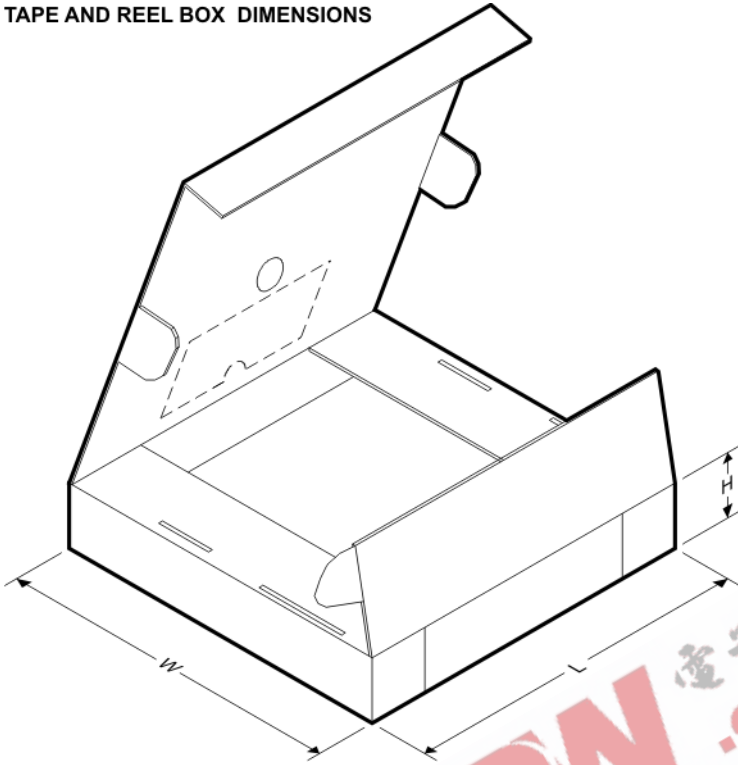

Device	Package	Pins	Site	Length (mm)	Width (mm)	Height (mm)
SN74LVCE161284DGGR	DGG	48	SITE 41	346.0	346.0	41.0
SN74LVCE161284DLR	DL	48	SITE 41	346.0	346.0	49.0
SN74LVCE161284VR	DGV	48	SITE 41	346.0	346.0	41.0

MECHANICAL DATA

MPDS006C – FEBRUARY 1996 – REVISED AUGUST 2000

DGV (R-PDSO-G**)

PLASTIC SMALL-OUTLINE

24 PINS SHOWN

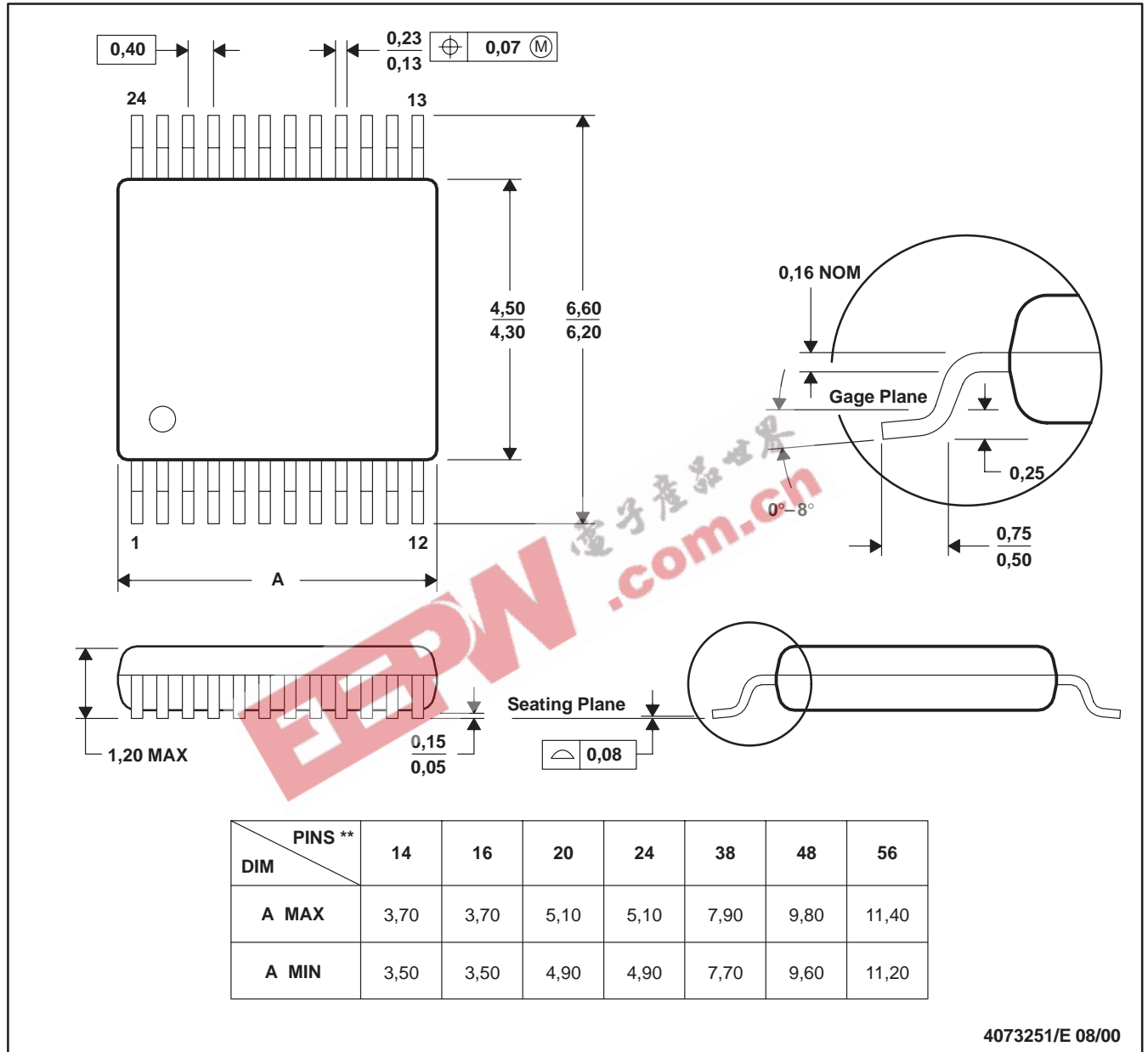

- NOTES: A. All linear dimensions are in millimeters.
 B. This drawing is subject to change without notice.
 C. Body dimensions do not include mold flash or protrusion, not to exceed 0,15 per side.
 D. Falls within JEDEC: 24/48 Pins – MO-153
 14/16/20/56 Pins – MO-194

MECHANICAL DATA

MSS0001C – JANUARY 1995 – REVISED DECEMBER 2001

DL (R-PDSO-G**)

PLASTIC SMALL-OUTLINE PACKAGE

48 PINS SHOWN

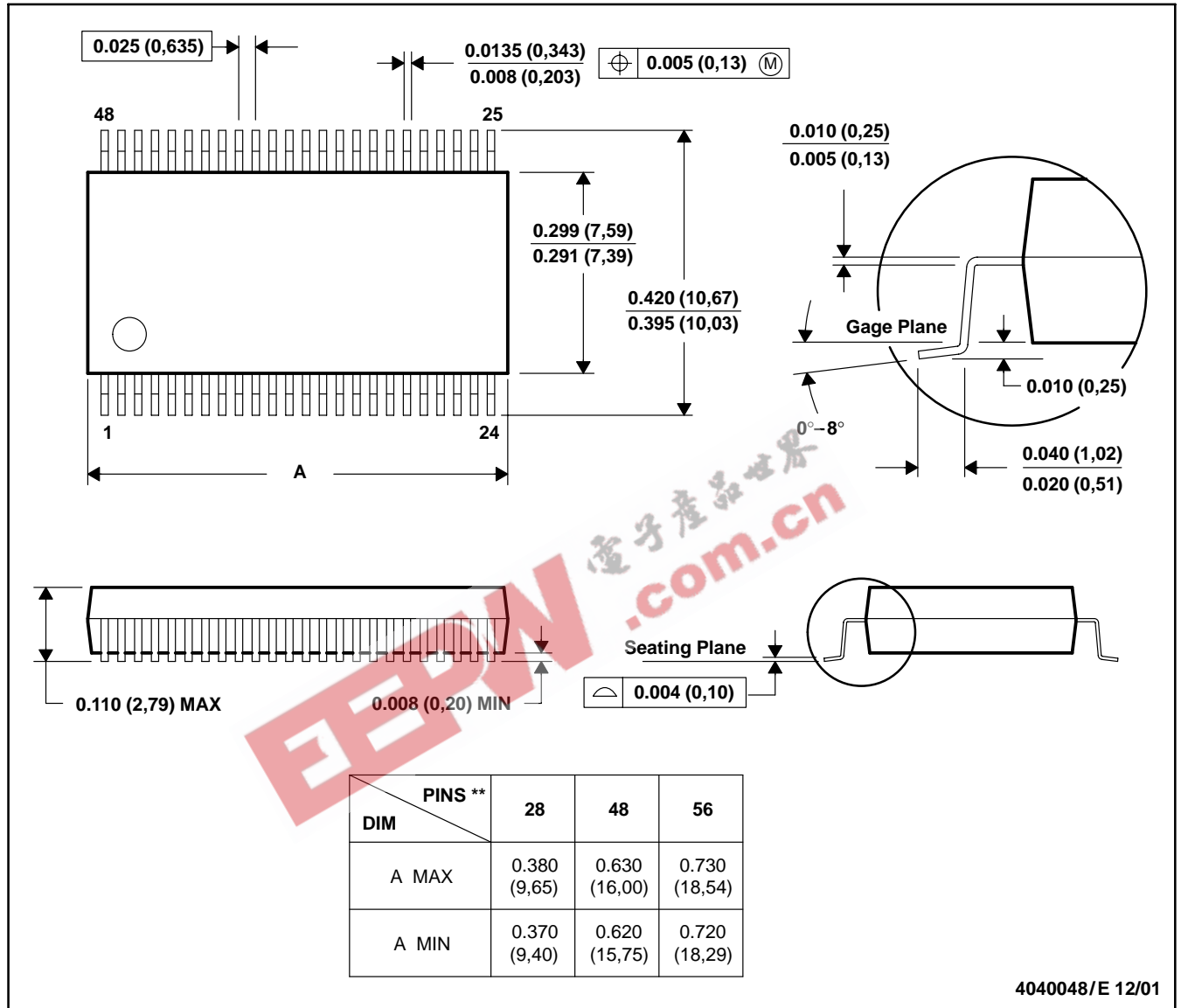

- NOTES: A. All linear dimensions are in inches (millimeters).
 B. This drawing is subject to change without notice.
 C. Body dimensions do not include mold flash or protrusion not to exceed 0.006 (0,15).
 D. Falls within JEDEC MO-118

MECHANICAL DATA

MTSS003D – JANUARY 1995 – REVISED JANUARY 1998

DGG (R-PDSO-G**)

PLASTIC SMALL-OUTLINE PACKAGE

48 PINS SHOWN

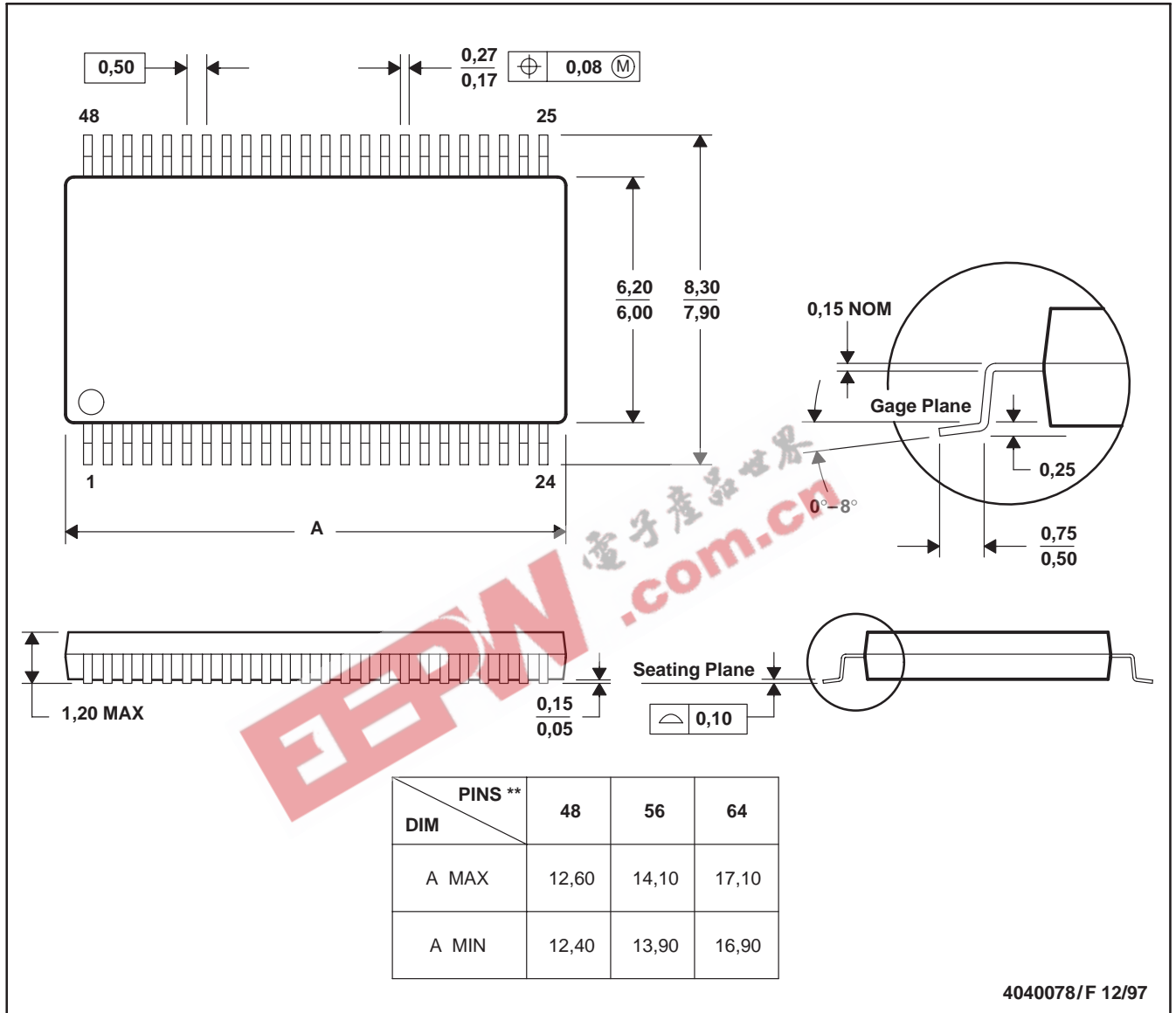

- NOTES:
- A. All linear dimensions are in millimeters.
 - B. This drawing is subject to change without notice.
 - C. Body dimensions do not include mold protrusion not to exceed 0,15.
 - D. Falls within JEDEC MO-153

IMPORTANT NOTICE

Texas Instruments Incorporated and its subsidiaries (TI) reserve the right to make corrections, modifications, enhancements, improvements, and other changes to its products and services at any time and to discontinue any product or service without notice. Customers should obtain the latest relevant information before placing orders and should verify that such information is current and complete. All products are sold subject to TI's terms and conditions of sale supplied at the time of order acknowledgment.

TI warrants performance of its hardware products to the specifications applicable at the time of sale in accordance with TI's standard warranty. Testing and other quality control techniques are used to the extent TI deems necessary to support this warranty. Except where mandated by government requirements, testing of all parameters of each product is not necessarily performed.

TI assumes no liability for applications assistance or customer product design. Customers are responsible for their products and applications using TI components. To minimize the risks associated with customer products and applications, customers should provide adequate design and operating safeguards.

TI does not warrant or represent that any license, either express or implied, is granted under any TI patent right, copyright, mask work right, or other TI intellectual property right relating to any combination, machine, or process in which TI products or services are used. Information published by TI regarding third-party products or services does not constitute a license from TI to use such products or services or a warranty or endorsement thereof. Use of such information may require a license from a third party under the patents or other intellectual property of the third party, or a license from TI under the patents or other intellectual property of TI.

Reproduction of TI information in TI data books or data sheets is permissible only if reproduction is without alteration and is accompanied by all associated warranties, conditions, limitations, and notices. Reproduction of this information with alteration is an unfair and deceptive business practice. TI is not responsible or liable for such altered documentation. Information of third parties may be subject to additional restrictions.

Resale of TI products or services with statements different from or beyond the parameters stated by TI for that product or service voids all express and any implied warranties for the associated TI product or service and is an unfair and deceptive business practice. TI is not responsible or liable for any such statements.

TI products are not authorized for use in safety-critical applications (such as life support) where a failure of the TI product would reasonably be expected to cause severe personal injury or death, unless officers of the parties have executed an agreement specifically governing such use. Buyers represent that they have all necessary expertise in the safety and regulatory ramifications of their applications, and acknowledge and agree that they are solely responsible for all legal, regulatory and safety-related requirements concerning their products and any use of TI products in such safety-critical applications, notwithstanding any applications-related information or support that may be provided by TI. Further, Buyers must fully indemnify TI and its representatives against any damages arising out of the use of TI products in such safety-critical applications.

TI products are neither designed nor intended for use in military/aerospace applications or environments unless the TI products are specifically designated by TI as military-grade or "enhanced plastic." Only products designated by TI as military-grade meet military specifications. Buyers acknowledge and agree that any such use of TI products which TI has not designated as military-grade is solely at the Buyer's risk, and that they are solely responsible for compliance with all legal and regulatory requirements in connection with such use.

TI products are neither designed nor intended for use in automotive applications or environments unless the specific TI products are designated by TI as compliant with ISO/TS 16949 requirements. Buyers acknowledge and agree that, if they use any non-designated products in automotive applications, TI will not be responsible for any failure to meet such requirements.

Following are URLs where you can obtain information on other Texas Instruments products and application solutions:

Products		Applications	
Amplifiers	amplifier.ti.com	Audio	www.ti.com/audio
Data Converters	dataconverter.ti.com	Automotive	www.ti.com/automotive
DSP	dsp.ti.com	Broadband	www.ti.com/broadband
Interface	interface.ti.com	Digital Control	www.ti.com/digitalcontrol
Logic	logic.ti.com	Military	www.ti.com/military
Power Mgmt	power.ti.com	Optical Networking	www.ti.com/opticalnetwork
Microcontrollers	microcontroller.ti.com	Security	www.ti.com/security
RFID	www.ti-rfid.com	Telephony	www.ti.com/telephony
Low Power Wireless	www.ti.com/lpw	Video & Imaging	www.ti.com/video
		Wireless	www.ti.com/wireless

Mailing Address: Texas Instruments, Post Office Box 655303, Dallas, Texas 75265
Copyright © 2007, Texas Instruments Incorporated