

## 74LCXH16244

### Low Voltage 16-Bit Buffer/Line Driver with Bushold

#### General Description

The LCXH16244 contains sixteen non-inverting buffers with 3-STATE outputs designed to be employed as a memory and address driver, clock driver, or bus oriented transmitter/receiver. The device is nibble controlled. Each nibble has separate 3-STATE control inputs which can be shorted together for full 16-bit operation.

The LCXH16244 data inputs include active bushold circuitry, eliminating the need for external pull-up resistors to hold unused or floating data inputs at a valid logic level.

The LCXH16244 is designed for low voltage (2.5V or 3.3V)  $V_{CC}$  applications with capability of interfacing to a 5V signal environment.

The LCXH16244 is fabricated with an advanced CMOS technology to achieve high speed operation while maintaining CMOS low power dissipation.

#### Features

- 5V tolerant control inputs and outputs
- 2.3V–3.6V  $V_{CC}$  specifications provided
- 4.5 ns  $t_{PD}$  max ( $V_{CC} = 3.0V$ ), 20  $\mu A$   $I_{CC}$  max
- Bushold on inputs eliminates the need for external pull-up/pull-down resistors
- Power down high impedance inputs and outputs
- $\pm 24$  mA output drive ( $V_{CC} = 3.0V$ )
- Implements patented noise/EMI reduction circuitry
- Latch-up performance exceeds 500 mA
- ESD performance:
  - Human body model > 2000V
  - Machine model > 200V

#### Ordering Code:

Order Number	Package Number	Package Description
74LCXH16244MEA	MS48A	48-Lead Small Shrink Outline Package (SSOP), JEDEC MO-118, 0.300 Wide
74LCXH16244MTD	MTD48	48-Lead Thin Shrink Small Outline Package (TSSOP), JEDEC MO-153, 6.1mm Wide

Devices also available in Tape and Reel. Specify by appending the suffix letter "X" to the ordering code.

#### Connection Diagram

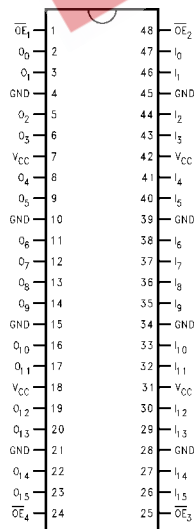

#### Logic Symbol

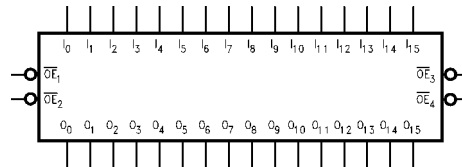

#### Pin Descriptions

Pin Names	Description
$\overline{OE}_n$	Output Enable Input (Active LOW)
$I_0$ – $I_{15}$	Bushold Inputs
$O_0$ – $O_{15}$	Outputs

## Truth Tables

Inputs		Outputs
$\overline{OE}_1$	I <sub>0</sub> -I <sub>3</sub>	O <sub>0</sub> -O <sub>3</sub>
L	L	L
L	H	H
H	X	Z

Inputs		Outputs
$\overline{OE}_3$	I <sub>8</sub> -I <sub>11</sub>	O <sub>8</sub> -O <sub>11</sub>
L	L	L
L	H	H
H	X	Z

Inputs		Outputs
$\overline{OE}_2$	I <sub>4</sub> -I <sub>7</sub>	O <sub>4</sub> -O <sub>7</sub>
L	L	L
L	H	H
H	X	Z

Inputs		Outputs
$\overline{OE}_4$	I <sub>12</sub> -I <sub>15</sub>	O <sub>12</sub> -O <sub>15</sub>
L	L	L
L	H	H
H	X	Z

H = HIGH Voltage Level  
L = LOW Voltage Level

X = Immaterial  
Z = High Impedance

## Functional Description

The LCXH16244 contains sixteen non-inverting buffers with 3-STATE standard outputs. The device is nibble (4 bits) controlled with each nibble functioning identically, but independent of the other. The control pins can be shorted together to obtain full 16-bit operation. The

3-STATE outputs are controlled by an Output Enable ( $\overline{OE}_n$ ) input for each nibble. When  $\overline{OE}_n$  is LOW, the outputs are in 2-state mode. When  $\overline{OE}_n$  is HIGH, the outputs are in the high impedance mode, but this does not interfere with entering new data into the inputs.

## Logic Diagram

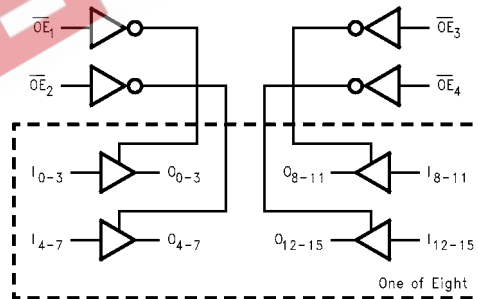

Absolute Maximum Ratings (Note 1)							
Symbol	Parameter		Value	Conditions	Units		
V <sub>CC</sub>	Supply Voltage		-0.5 to +7.0		V		
V <sub>I</sub>	DC Input Voltage	$\overline{OE}$	-0.5 to +7.0		V		
		I <sub>0</sub> - I <sub>15</sub>	-0.5 to V <sub>CC</sub> + 0.5				
V <sub>O</sub>	DC Output Voltage		-0.5 to +7.0	Output in 3-STATE	V		
			-0.5 to V <sub>CC</sub> + 0.5	Output in HIGH or LOW State (Note 2)			
I <sub>IK</sub>	DC Input Diode Current		-50	V <sub>I</sub> < GND	mA		
I <sub>OK</sub>	DC Output Diode Current		-50	V <sub>O</sub> < GND	mA		
			+50	V <sub>O</sub> > V <sub>CC</sub>			
I <sub>O</sub>	DC Output Source/Sink Current		±50		mA		
I <sub>CC</sub>	DC Supply Current per Supply Pin		±100		mA		
I <sub>GND</sub>	DC Ground Current per Ground Pin		±100		mA		
T <sub>STG</sub>	Storage Temperature		-65 to +150		°C		
Recommended Operating Conditions (Note 3)							
Symbol	Parameter			Min	Max	Units	
V <sub>CC</sub>	Supply Voltage			Operating	2.0	3.6	V
				Data Retention	1.5	3.6	
V <sub>I</sub>	Input Voltage			0	V <sub>CC</sub>	V	
V <sub>O</sub>	Output Voltage			HIGH or LOW State	0	V <sub>CC</sub>	V
				3-STATE	0	5.5	
I <sub>OH</sub> /I <sub>OL</sub>	Output Current			V <sub>CC</sub> = 3.0V - 3.6V		±24	mA
				V <sub>CC</sub> = 2.7V - 3.0V		±12	
				V <sub>CC</sub> = 2.3V - 2.7V		±8	
T <sub>A</sub>	Free-Air Operating Temperature			-40	85	°C	
Δt/ΔV	Input Edge Rate, V <sub>IN</sub> = 0.8V-2.0V, V <sub>CC</sub> = 3.0V			0	10	ns/V	
<p><b>Note 1:</b> The Absolute Maximum Ratings are those values beyond which the safety of the device cannot be guaranteed. The device should not be operated at these limits. The parametric values defined in the Electrical Characteristics tables are not guaranteed at the Absolute Maximum Ratings. The "Recommended Operating Conditions" table will define the conditions for actual device operation.</p> <p><b>Note 2:</b> I<sub>O</sub> Absolute Maximum Rating must be observed.</p> <p><b>Note 3:</b> Floating or unused control inputs must be held HIGH or LOW.</p>							
DC Electrical Characteristics							
Symbol	Parameter	Conditions	V <sub>CC</sub> (V)	T <sub>A</sub> = -40°C to +85°C		Units	
				Min	Max		
V <sub>IH</sub>	HIGH Level Input Voltage		2.3 - 2.7	1.7		V	
			2.7 - 3.6	2.0			
V <sub>IL</sub>	LOW Level Input Voltage		2.3 - 2.7		0.7	V	
			2.7 - 3.6		0.8		
V <sub>OH</sub>	HIGH Level Output Voltage	I <sub>OH</sub> = -100 μA	2.3 - 3.6	V <sub>CC</sub> - 0.2		V	
		I <sub>OH</sub> = -8 mA	2.3	1.8			
		I <sub>OH</sub> = -12 mA	2.7	2.2			
		I <sub>OH</sub> = -18 mA	3.0	2.4			
		I <sub>OH</sub> = -24 mA	3.0	2.2			
V <sub>OL</sub>	LOW Level Output Voltage	I <sub>OL</sub> = 100 μA	2.3 - 3.6		0.2	V	
		I <sub>OL</sub> = 8 mA	2.3		0.6		
		I <sub>OL</sub> = 12 mA	2.7		0.4		
		I <sub>OL</sub> = 16 mA	3.0		0.4		
		I <sub>OL</sub> = 24 mA	3.0		0.55		
I <sub>I</sub>	Input Leakage Current	Data	V <sub>I</sub> = V <sub>CC</sub> or GND	2.3 - 3.6	±5.0	μA	
		Control	0 ≤ V <sub>I</sub> ≤ 5.5	2.3 - 3.6	±5.0		

## DC Electrical Characteristics (Continued)

Symbol	Parameter	Conditions	V <sub>CC</sub> (V)	T <sub>A</sub> = -40°C to +85°C		Units
				Min	Max	
I <sub>I(HOLD)</sub>	Bushold Input Minimum Drive Hold Current	V <sub>IN</sub> = 0.7V	2.3	45		μA
		V <sub>IN</sub> = 1.7V		-45		
		V <sub>IN</sub> = 0.8V	3.0	75		
		V <sub>IN</sub> = 2.0V		-75		
I <sub>I(OD)</sub>	Bushold Input Over-Drive Current to Change State	(Note 4)	2.7	300		μA
		(Note 5)		-300		
		(Note 4)	3.6	450		
		(Note 5)		-450		
I <sub>OZ</sub>	3-STATE Output Leakage	0 ≤ V <sub>O</sub> ≤ 5.5V V <sub>I</sub> = V <sub>IH</sub> or V <sub>IL</sub>	2.3 – 3.6		±5.0	μA
I <sub>OFF</sub>	Power-Off Leakage Current	V <sub>O</sub> = 5.5V	0		10	μA
I <sub>CC</sub>	Quiescent Supply Current	V <sub>I</sub> = V <sub>CC</sub> or GND	2.3 – 3.6		20	μA
ΔI <sub>CC</sub>	Increase in I <sub>CC</sub> per Input	V <sub>IH</sub> = V <sub>CC</sub> - 0.6V	2.3 – 3.6		500	μA

**Note 4:** An external driver must source at least the specified current to switch from LOW-to-HIGH.

**Note 5:** An external driver must sink at least the specified current to switch from HIGH-to-LOW.

## AC Electrical Characteristics

Symbol	Parameter	T <sub>A</sub> = -40°C to +85°C, R <sub>L</sub> = 500 Ω						Units
		V <sub>CC</sub> = 3.3V ± 0.3V		V <sub>CC</sub> = 2.7V		V <sub>CC</sub> = 2.5V ± 0.2V		
		C <sub>L</sub> = 50 pF		C <sub>L</sub> = 50 pF		C <sub>L</sub> = 30 pF		
		Min	Max	Min	Max	Min	Max	
t <sub>PHL</sub>	Propagation Delay	1.0	4.5	1.0	5.2	1.0	5.4	ns
t <sub>PLH</sub>	Data to Output	1.0	4.5	1.0	5.2	1.0	5.4	
t <sub>PZL</sub>	Output Enable Time	1.0	5.5	1.0	6.3	1.0	7.2	ns
t <sub>PZH</sub>		1.0	5.5	1.0	6.3	1.0	7.2	
t <sub>PLZ</sub>	Output Disable Time	1.0	5.4	1.0	5.7	1.0	6.5	ns
t <sub>PHZ</sub>		1.0	5.4	1.0	5.7	1.0	6.5	
t <sub>OSSL</sub>	Output to Output Skew (Note 6)		1.0					ns
t <sub>OSLH</sub>			1.0					

**Note 6:** Skew is defined as the absolute value of the difference between the actual propagation delay for any two separate outputs of the same device. The specification applies to any outputs switching in the same direction, either HIGH-to-LOW (t<sub>OSSL</sub>) or LOW-to-HIGH (t<sub>OSLH</sub>). Parameter guaranteed by design.

Dynamic Switching Characteristics					
Symbol	Parameter	Conditions	V <sub>CC</sub> (V)	T <sub>A</sub> = 25°C	Units
				Typical	
V <sub>OLP</sub>	Quiet Output Dynamic Peak V <sub>OL</sub>	C <sub>L</sub> = 50 pF, V <sub>IH</sub> = 3.3V, V <sub>IL</sub> = 0V C <sub>L</sub> = 30 pF, V <sub>IH</sub> = 2.5V, V <sub>IL</sub> = 0V	3.3	0.8	V
			2.5	0.6	
V <sub>OLV</sub>	Quiet Output Dynamic Valley V <sub>OL</sub>	C <sub>L</sub> = 50 pF, V <sub>IH</sub> = 3.3V, V <sub>IL</sub> = 0V C <sub>L</sub> = 30 pF, V <sub>IH</sub> = 2.5V, V <sub>IL</sub> = 0V	3.3	-0.8	V
			2.5	-0.6	

Capacitance					
Symbol	Parameter	Conditions	Typical	Units	
C <sub>IN</sub>	Input Capacitance	V <sub>CC</sub> = Open, V <sub>I</sub> = 0V or V <sub>CC</sub>	7	pF	
C <sub>OUT</sub>	Output Capacitance	V <sub>CC</sub> = 3.3V, V <sub>I</sub> = 0V or V <sub>CC</sub>	8	pF	
C <sub>PD</sub>	Power Dissipation Capacitance	V <sub>CC</sub> = 3.3V, V <sub>I</sub> = 0V or V <sub>CC</sub> , f = 10 MHz	20	pF	

EEPW 电子产品世界  
.com.cn

**AC LOADING and WAVEFORMS** Generic for LCX Family

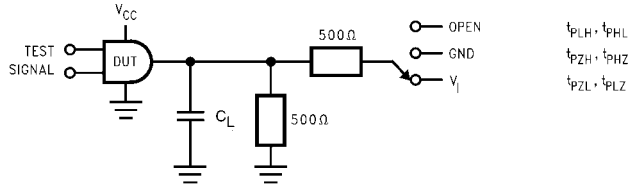

**FIGURE 1. AC Test Circuit ( $C_L$  includes probe and jig capacitance)**

$V_I$	$C_L$
6V for $V_{CC} = 3.3V, 2.7V$	50 pF
$V_{CC} * 2$ for $V_{CC} = 2.5V$	30 pF

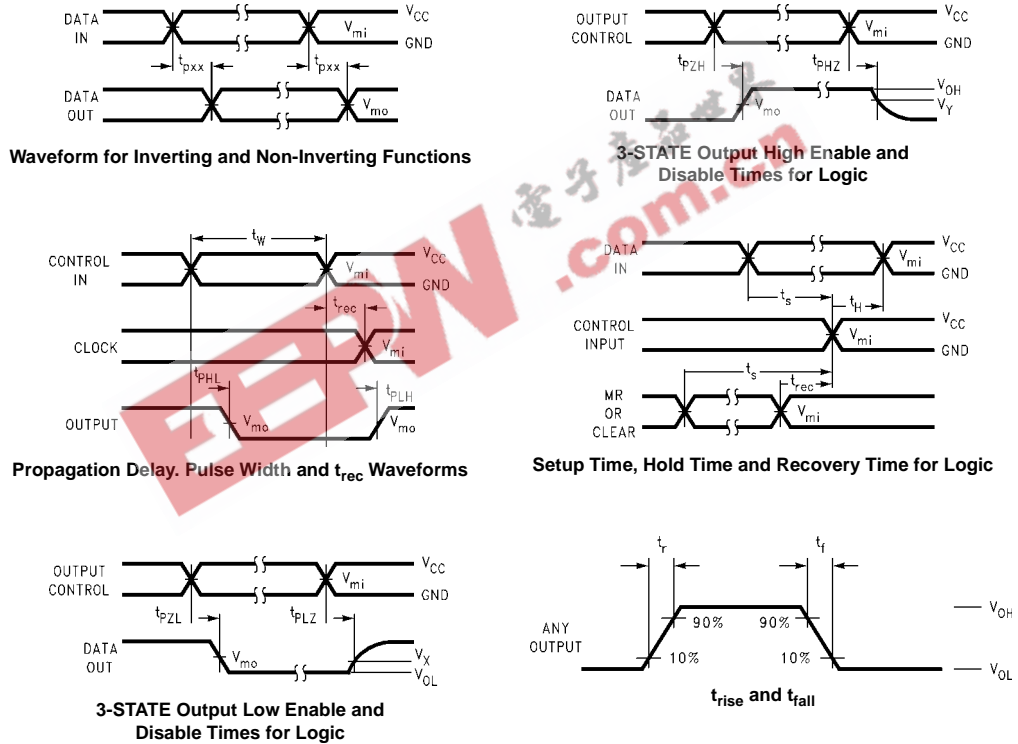

**FIGURE 2. Waveforms**  
(Input Characteristics;  $f = 1MHz, t_R = t_F = 3ns$ )

Symbol	$V_{CC}$		
	$3.3V \pm 0.3V$	$2.7V$	$2.5V \pm 0.2V$
$V_{mi}$	1.5V	1.5V	$V_{CC}/2$
$V_{mo}$	1.5V	1.5V	$V_{CC}/2$
$V_x$	$V_{OL} + 0.3V$	$V_{OL} + 0.3V$	$V_{OL} + 0.15V$
$V_y$	$V_{OH} - 0.3V$	$V_{OH} - 0.3V$	$V_{OH} - 0.15V$

**Schematic Diagram** Generic for LCXH Family

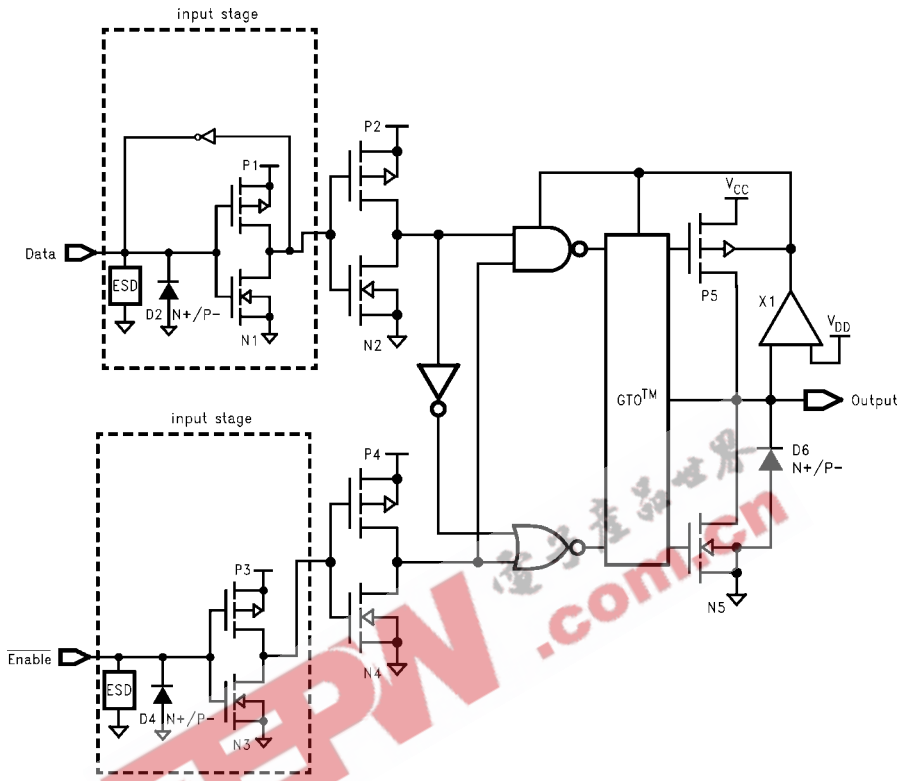

74LCXH16244

74LCXH16244

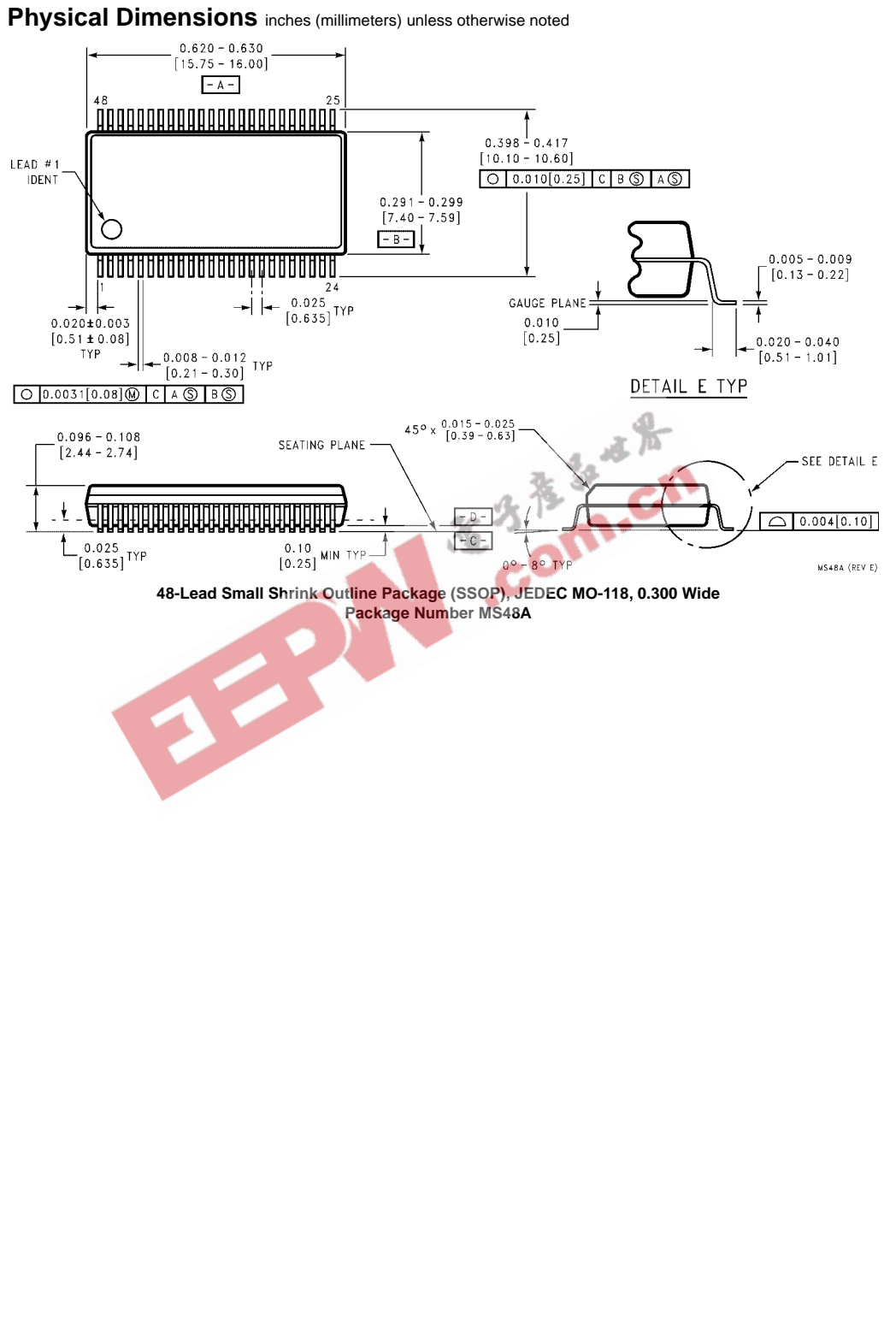



**Physical Dimensions** inches (millimeters) unless otherwise noted (Continued)

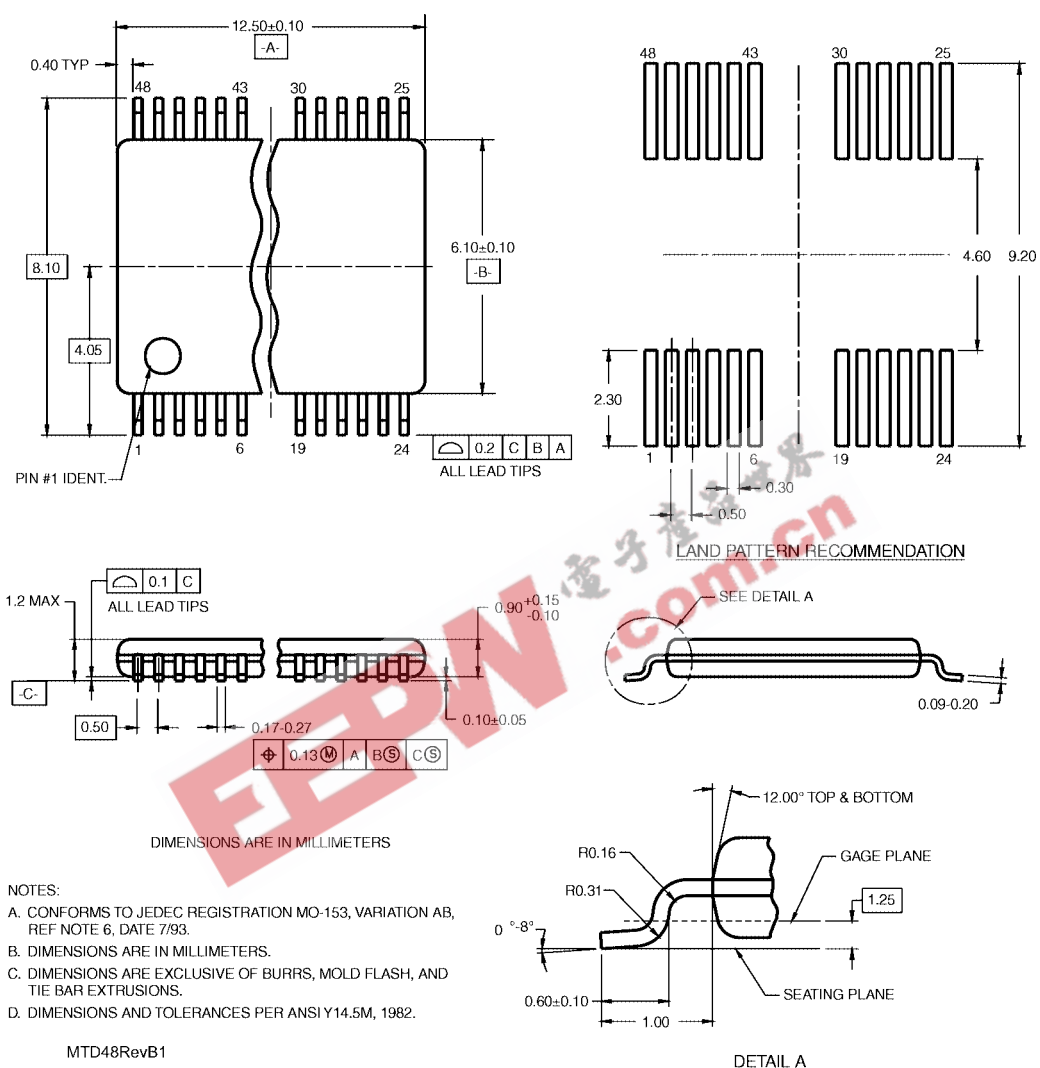

Fairchild does not assume any responsibility for use of any circuitry described, no circuit patent licenses are implied and Fairchild reserves the right at any time without notice to change said circuitry and specifications.

**LIFE SUPPORT POLICY**

FAIRCHILD'S PRODUCTS ARE NOT AUTHORIZED FOR USE AS CRITICAL COMPONENTS IN LIFE SUPPORT DEVICES OR SYSTEMS WITHOUT THE EXPRESS WRITTEN APPROVAL OF THE PRESIDENT OF FAIRCHILD SEMICONDUCTOR CORPORATION. As used herein:

1. Life support devices or systems are devices or systems which, (a) are intended for surgical implant into the body, or (b) support or sustain life, and (c) whose failure to perform when properly used in accordance with instructions for use provided in the labeling, can be reasonably expected to result in a significant injury to the user.
2. A critical component in any component of a life support device or system whose failure to perform can be reasonably expected to cause the failure of the life support device or system, or to affect its safety or effectiveness.

[www.fairchildsemi.com](http://www.fairchildsemi.com)