

54F/74F540 • 54F/74F541 Octal Buffer/Line Driver with TRI-STATE® Outputs

General Description

The 'F540 and 'F541 are similar in function to the 'F240 and 'F244 respectively, except that the inputs and outputs are on opposite sides of the package (see Connection Diagrams). This pinout arrangement makes these devices especially useful as output ports for microprocessors, allowing ease of layout and greater PC board density.

Features

- TRI-STATE outputs drive bus lines
- Inputs and outputs opposite side of package, allowing easier interface to microprocessors

Commercial	Military	Package Number	Package Description
74F540PC		N20A	20-Lead (0.300" Wide) Molded Dual-In-Line
	54F540DM (Note 2)	J20A	20-Lead Ceramic Dual-In-Line
74F540SC (Note 1)		M20B	20-Lead (0.300" Wide) Molded Small Outline, JEDEC
74F540SJ (Note 1)		M20D	20-Lead (0.300" Wide) Molded Small Outline, EIAJ
	54F540FM (Note 2)	W20A	20-Lead Cerpack
	54F540LM (Note 2)	E20A	20-Lead Ceramic Leadless Chip Carrier, Type C
74F541PC		N20A	20-Lead (0.300" Wide) Molded Dual-In-Line
	54F541DM (Note 2)	J20A	20-Lead Ceramic Dual-In-Line
74F541SC (Note 1)		M20B	20-Lead (0.300" Wide) Molded Small Outline, JEDEC
74F541SJ (Note 1)		M20D	20-Lead (0.300" Wide) Molded Small Outline, EIAJ
	54F541FM (Note 2)	W20A	20-Lead Cerpack
	54F541LM (Note 2)	E20A	20-Lead Ceramic Leadless Chip Carrier, Type C

Note 1: Devices also available in 13" reel. Use suffix = SCX and SJX.

Note 2: Military grade device with environmental and burn-in processing. Use suffix = DMQB, FMQB and LMQB.

Connection Diagrams

Pin Assignment for
DIP, SOIC and Flatpak

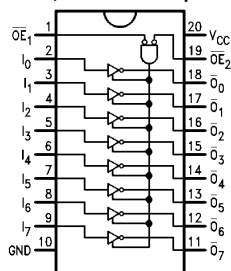

'F540

TL/F/9553-1

Pin Assignment
for LCC

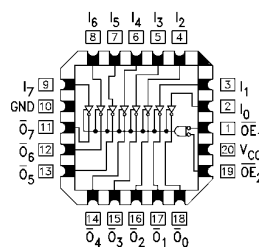

TL/F/9553-2

TRI-STATE® is a registered trademark of National Semiconductor Corporation.

Connection Diagrams (Continued)

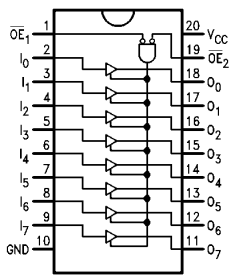

'F541

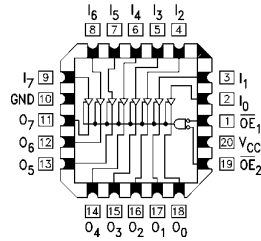

TL/F/9553-4

TL/F/9553-5

Unit Loading/Fan Out

Pin Names	Description	54F/74F	
		U.L. HIGH/LOW	Input I_{IH}/I_{IL} Output I_{OH}/I_{OL}
$\overline{OE}_1, \overline{OE}_2$	TRI-STATE Output Enable Input (Active LOW)	1.0/1.0	$20 \mu\text{A} / -0.6 \text{ mA}$
I_n	Inputs	1.0/1.0	$20 \mu\text{A} / -0.6 \text{ mA}$
O_n, \overline{O}_n	Outputs	600/106.6 (80)	$-12 \text{ mA} / 64 \text{ mA} (48 \text{ mA})$

Truth Table

Inputs			Outputs	
\overline{OE}_1	\overline{OE}_2	I	'F540	'F541
L	L	H	L	H
H	X	X	Z	Z
X	H	X	Z	Z
L	L	L	H	L

H = HIGH Voltage Level
L = LOW Voltage Level
X = Immaterial
Z = High Impedance

Logic Diagrams

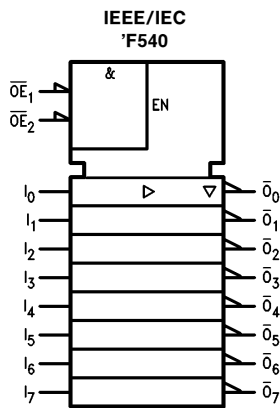

TL/F/9553-3

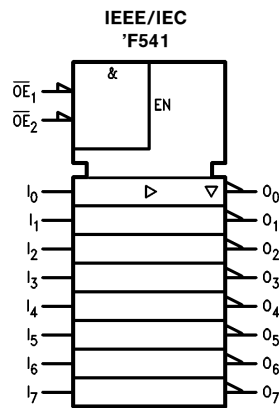

TL/F/9553-6

Absolute Maximum Ratings (Note 1)

If Military/Aerospace specified devices are required, please contact the National Semiconductor Sales Office/Distributors for availability and specifications.

Storage Temperature	-65°C to +150°C
Ambient Temperature under Bias	-55°C to +125°C
Junction Temperature under Bias	-55°C to +175°C
Plastic	-55°C to +150°C
V _{CC} Pin Potential to Ground Pin	-0.5V to +7.0V
Input Voltage (Note 2)	-0.5V to +7.0V
Input Current (Note 2)	-30 mA to +5.0 mA
Voltage Applied to Output in HIGH State (with V _{CC} = 0V)	
Standard Output	-0.5V to V _{CC}
TRI-STATE Output	-0.5V to +5.5V
Current Applied to Output in LOW State (Max)	twice the rated I _{OL} (mA)

Note 1: Absolute maximum ratings are values beyond which the device may be damaged or have its useful life impaired. Functional operation under these conditions is not implied.

Note 2: Either voltage limit or current limit is sufficient to protect inputs.

Recommended Operating Conditions

Free Air Ambient Temperature	
Military	-55°C to +125°C
Commercial	0°C to +70°C
Supply Voltage	
Military	+4.5V to +5.5V
Commercial	+4.5V to +5.5V

DC Electrical Characteristics

Symbol	Parameter	54F/74F			Units	V _{CC}	Conditions
		Min	Typ	Max			
V _{IH}	Input HIGH Voltage	2.0			V		Recognized as a HIGH Signal
V _{IL}	Input LOW Voltage			0.8	V		Recognized as a LOW Signal
V _{CD}	Input Clamp Diode Voltage			-1.2	V	Min	I _{IN} = -18 mA
V _{OH}	Output HIGH Voltage	54F 10% V _{CC} 54F 10% V _{CC} 74F 10% V _{CC} 74F 10% V _{CC} 74F 5% V _{CC}	2.4 2.0 2.4 2.0 2.7		V	Min	I _{OH} = -3 mA I _{OH} = -12 mA I _{OH} = -3 mA I _{OH} = -15 mA I _{OH} = -3 mA
V _{OL}	Output LOW Voltage	54F 10% V _{CC} 74F 10% V _{CC}		0.55 0.55	V	Min	I _{OL} = 48 mA I _{OL} = 64 mA
I _{IH}	Input HIGH Current	54F 74F		20.0 5.0	μA	Max	V _{IN} = 2.7V
I _{BVI}	Input HIGH Current Breakdown Test	54F 74F		100 7.0	μA	Max	V _{IN} = 7.0V
I _{CEX}	Output HIGH Leakage Current	54F 74F		250 50	μA	Max	V _{OUT} = V _{CC}
V _{ID}	Input Leakage Test	74F	4.75		V	0.0	I _{ID} = 1.9 μA All Other Pins Grounded
I _{OD}	Output Leakage Circuit Current	74F		3.75	μA	0.0	V _{IOD} = 150 mV All Other Pins Grounded
I _{IL}	Input LOW Current			-0.6	mA	Max	V _{IN} = 0.5V
I _{OZH}	Output Leakage Current			50	μA	Max	V _{OUT} = 2.7V
I _{OZL}	Output Leakage Current			-50	μA	Max	V _{OUT} = 0.5V
I _{OS}	Output Short-Circuit Current			-100	mA	Max	V _{OUT} = 0V
I _{ZZ}	Bus Drainage Test			500	μA	0.0V	V _{OUT} = 5.25V

DC Electrical Characteristics (Continued)

Symbol	Parameter	54F/74F			Units	V _{CC}	Conditions
		Min	Typ	Max			
I _{CCH}	Power Supply Current ('F540)		11	20	mA	Max	V _O = HIGH
I _{CCL}	Power Supply Current ('F540)		53	75	mA	Max	V _O = LOW
I _{CCZ}	Power Supply Current ('F540)		31	45	mA	Max	V _O = HIGH Z
I _{CCH}	Power Supply Current ('F541)		26	35	mA	Max	V _O = HIGH
I _{CCL}	Power Supply Current ('F541)		55	75	mA	Max	V _O = LOW
I _{CCZ}	Power Supply Current ('F541)		31	55	mA	Max	V _O = HIGH Z

AC Electrical Characteristics

Symbol	Parameter	74F			54F		74F		Units
		T _A = +25°C V _{CC} = +5.0V C _L = 50 pF			T _A , V _{CC} = Mil C _L = 50 pF		T _A , V _{CC} = Com C _L = 50 pF		
		Min	Typ	Max	Min	Max	Min	Max	
t _{PLH}	Propagation Delay	1.5	3.0	5.0	1.0	6.0	1.0	5.5	ns
t _{PHL}	Data to Output ('F540)	1.0	2.0	4.0	1.0	4.5	1.0	4.0	
t _{PZH}	Output Enable Time ('F540)	2.5	4.9	8.0	2.5	9.0	2.5	8.5	ns
t _{PZL}		3.5	5.8	10.0	3.5	11.0	3.5	10.5	
t _{PHZ}	Output Disable Time ('F540)	1.5	3.4	6.0	1.5	7.0	1.5	6.5	ns
t _{PLZ}		1.0	2.5	5.5	1.0	7.5	1.0	6.0	
t _{PLH}	Propagation Delay	1.5	3.3	5.5			1.5	6.0	ns
t _{PHL}	Data to Output ('F541)	1.5	2.7	5.5			1.5	6.0	
t _{PZH}	Output Enable Time ('F541)	3.0	5.8	8.0			2.5	9.5	ns
t _{PZL}		3.5	6.1	8.5			3.0	9.5	
t _{PHZ}	Output Disable Time ('F541)	1.5	3.4	6.0			1.5	6.5	ns
t _{PLZ}		1.5	2.9	5.5			1.5	6.0	

Ordering Information

The device number is used to form part of a simplified purchasing code where the package type and temperature range are defined as follows:

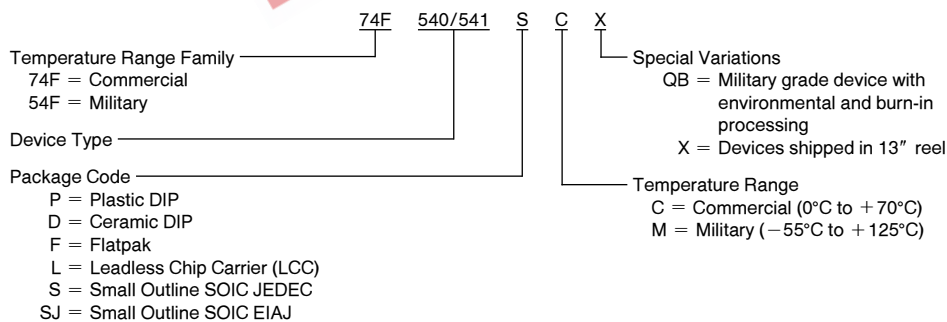

Physical Dimensions inches (millimeters) (Continued)

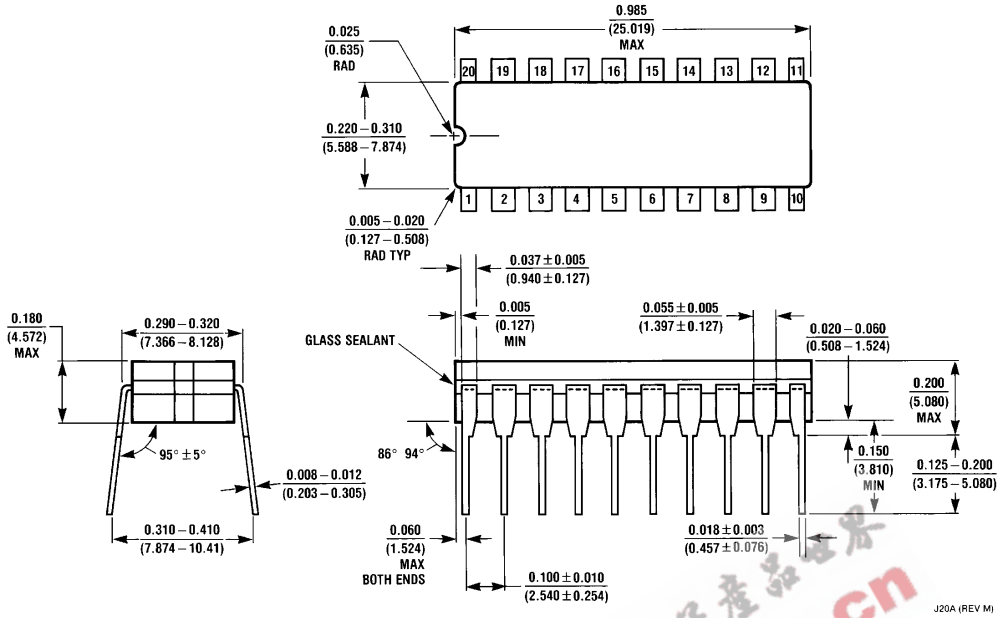

20-Lead Ceramic Dual-In-Lead Package (D)
NS Package Number J20A

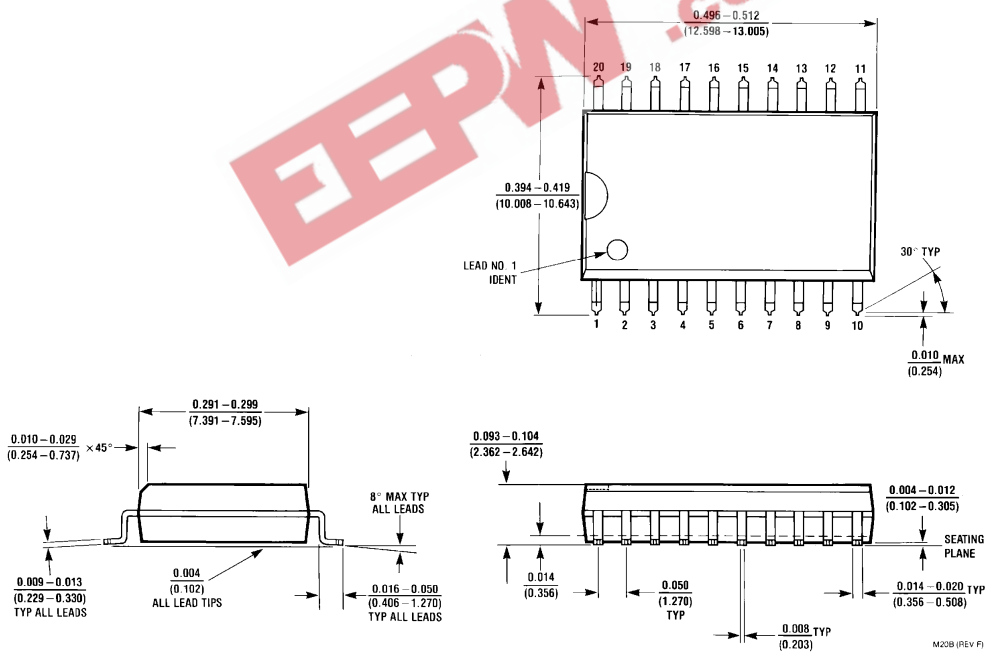

20-Lead (0.300" Wide) Molded Small Outline Package, JEDEC (S)
NS Package Number M20B

Physical Dimensions inches (millimeters) (Continued)

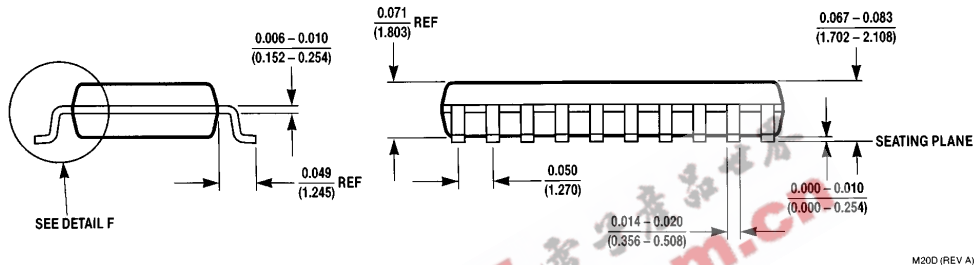
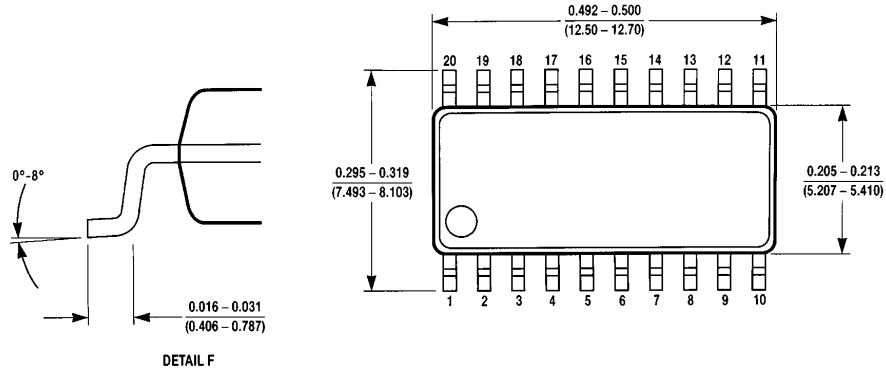

20-Lead (0.300" Wide) Molded Small Outline Package, EIAJ (SJ)
NS Package Number M20D

M20D (REV A)

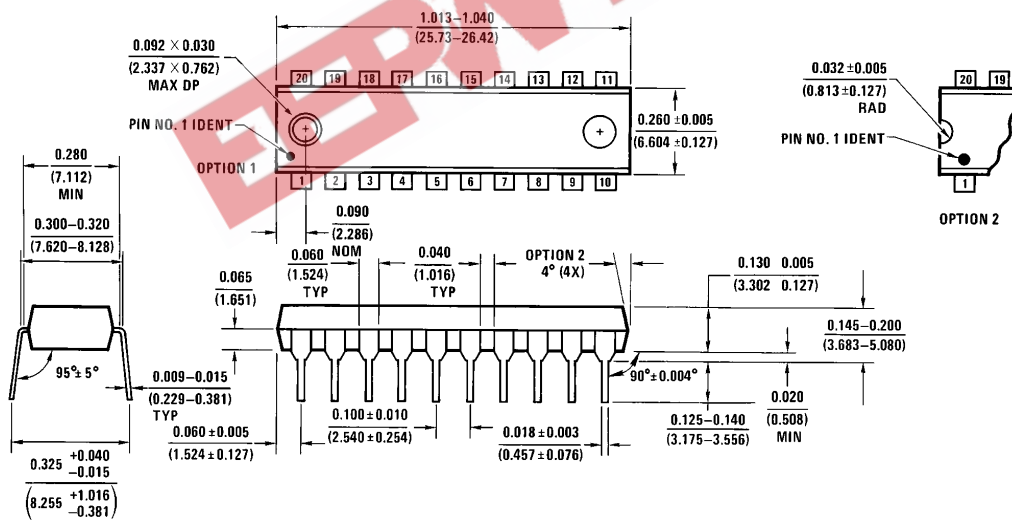

20-Lead (0.300" Wide) Molded Dual-In-Line Package (P)
NS Package Number N20A

N20A (REV G)

Physical Dimensions inches (millimeters) (Continued)

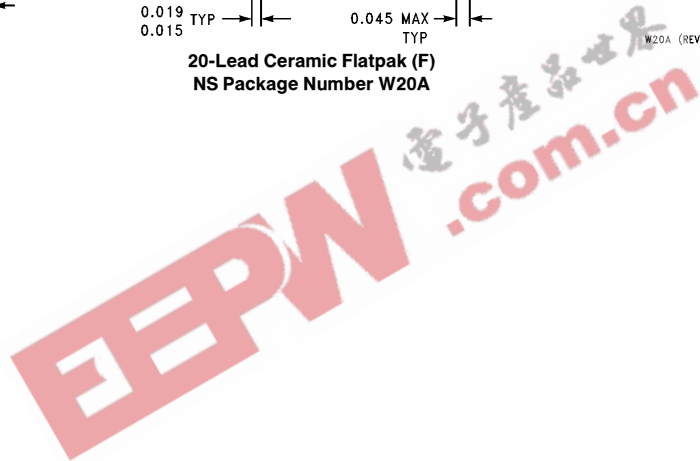
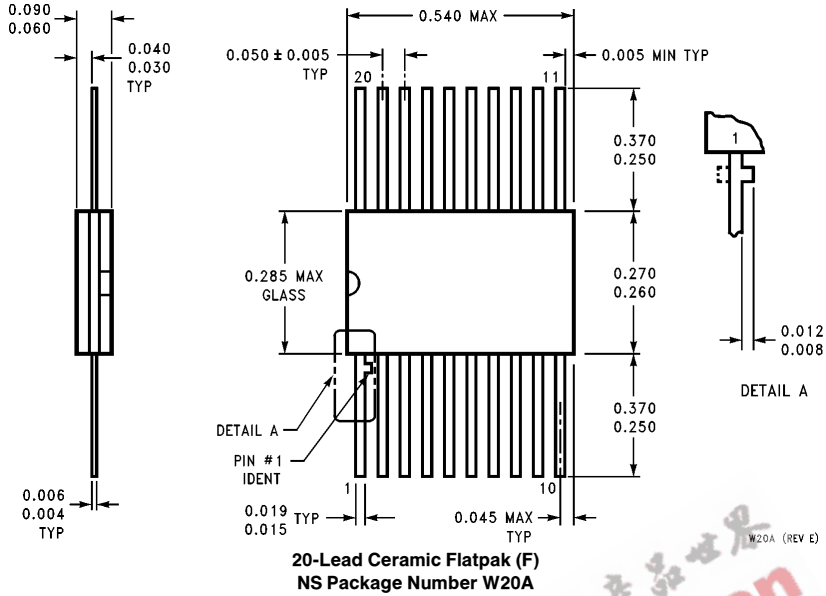

LIFE SUPPORT POLICY

NATIONAL'S PRODUCTS ARE NOT AUTHORIZED FOR USE AS CRITICAL COMPONENTS IN LIFE SUPPORT DEVICES OR SYSTEMS WITHOUT THE EXPRESS WRITTEN APPROVAL OF THE PRESIDENT OF NATIONAL SEMICONDUCTOR CORPORATION. As used herein:

1. Life support devices or systems are devices or systems which, (a) are intended for surgical implant into the body, or (b) support or sustain life, and whose failure to perform, when properly used in accordance with instructions for use provided in the labeling, can be reasonably expected to result in a significant injury to the user.
2. A critical component is any component of a life support device or system whose failure to perform can be reasonably expected to cause the failure of the life support device or system, or to affect its safety or effectiveness.



National Semiconductor Corporation
2900 Semiconductor Drive
P.O. Box 58090
Santa Clara, CA 95052-8090
Tel: 1 (800) 272-9959
TWX: (910) 339-9240

National Semiconductor GmbH
Livry-Gargan-Str. 10
D-82256 Fürstenfeldbruck
Germany
Tel: (81-41) 35-0
Telex: 527649
Fax: (81-41) 35-1

National Semiconductor Japan Ltd.
Sumitomo Chemical
Engineering Center
Bldg. 7F
1-7-1, Nakase, Mihama-Ku
Chiba-City,
Chiba Prefecture 261
Tel: (043) 299-2300
Fax: (043) 299-2500

National Semiconductor Hong Kong Ltd.
13th Floor, Straight Block,
Ocean Centre, 5 Canton Rd.
Tsimshatsui, Kowloon
Hong Kong
Tel: (852) 2737-1600
Fax: (852) 2736-9960

National Semiconductores Do Brazil Ltda.
Rua Deputado Lacorda Franco
120-3A
Sao Paulo-SP
Brazil 05418-000
Tel: (55-11) 212-5066
Telex: 391-1131931 NSBR BR
Fax: (55-11) 212-1181

National Semiconductor (Australia) Pty, Ltd.
Building 16
Business Park Drive
Monash Business Park
Nottingham, Melbourne
Victoria 3168 Australia
Tel: (3) 558-9889
Fax: (3) 558-9898

National does not assume any responsibility for use of any circuitry described, no circuit patent licenses are implied and National reserves the right at any time without notice to change said circuitry and specifications.