

74VHC14 Hex Schmitt Inverter

General Description

The 74VHC14 is an advanced high speed CMOS Hex Schmitt Inverter fabricated with silicon gate CMOS technology. It achieves the high speed operation similar to equivalent Bipolar Schottky TTL while maintaining the CMOS low power dissipation. Pin configuration and function are the same as the 74VHC04 but the inputs have hysteresis between the positive-going and negative-going input thresholds, which are capable of transforming slowly changing input signals into sharply defined, jitter-free output signals, thus providing greater noise margin than conventional inverters.

An input protection circuit ensures that 0V to 7V can be applied to the input pins without regard to the supply voltage. This device can be used to interface 5V to 3V systems and two supply systems such as battery back up. This circuit prevents device destruction due to mismatched supply and input voltages.

Features

- Low power dissipation:
 $I_{CC} = 2 \mu A$ (Max) at $T_A = 25^\circ C$
- High noise immunity: $V_{NIH} = V_{NIL} = 28\% V_{CC}$ (Min)
- All inputs are equipped with a power down protection function
- Balanced propagation delays: $T_{PLH} \cong T_{PHL}$
- Low noise: $V_{OLP} = 0.8V$ (Max)
- Pin and function compatible with 74HC14

Commercial	Package Number	Package Description
74VHC14M	M14A	14-Lead Molded JEDEC SOIC
74VHC14SJ	M14D	14-Lead Molded EIAJ SOIC
74VHC14MSC	MSC14	14-Lead Molded EIAJ Type 1 SSOP
74VHC14MTC	MTC14	14-Lead Molded JEDEC Type 1 TSSOP
74VHC14N	N14A	14-Lead Molded DIP

Note: Surface mount packages are also available on Tape and Reel. Specify by appending the suffix letter "X" to the ordering code. EIAJ Type 1 SSOP available on Tape and Reel only, order MSCX.

Logic Symbol

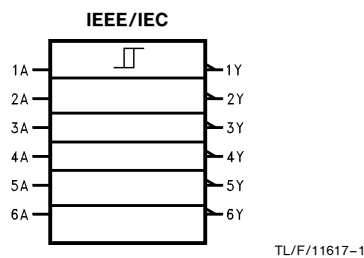

Connection Diagram

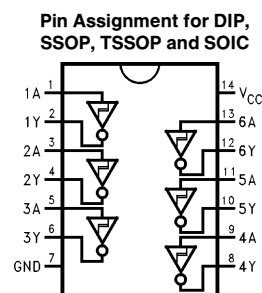

Truth Table

A-Inputs	Y-Outputs
L	H
H	L

Absolute Maximum Ratings (Note 1)

Supply Voltage (V_{CC})	-0.5V to +7.0V
DC Input Voltage (V_{IN})	-0.5V to +7.0V
DC Output Voltage (V_{OUT})	-0.5V to V_{CC} + 0.5V
Input Diode Current (I_{IK})	-20 mA
Output Diode Current (I_{OK})	±20 mA
DC Output Current (I_{OUT})	±25 mA
DC V_{CC} /GND Current (I_{CC})	±50 mA
Storage Temperature (T_{STG})	-65°C to +150°C
Lead Temperature (T_L)	
Soldering (10 seconds)	260°C

Note 1: Absolute maximum ratings are values beyond which the device may be damaged or have its useful life impaired. The data book specifications should be met, without exception, to ensure that the system design is reliable over its power supply, temperature, and output/input loading variables. National does not recommend operation outside data book specifications.

Recommended Operating Conditions

Supply Voltage (V_{CC})	+2.0V to +5.5V
Input Voltage (V_{IN})	0V to +5.5V
Output Voltage (V_{OUT})	0V to V_{CC}
Operating Temperature (T_{OPR})	-40°C to +85°C

DC Characteristics for 'VHC Family Devices

Symbol	Parameter	V_{CC}	74VHC			74VHC		Units	Conditions
			$T_A = 25^\circ\text{C}$			$T_A = -40^\circ\text{C}$ to $+85^\circ\text{C}$			
			Min	Typ	Max	Min	Max		
V_P	Positive Threshold Voltage	3.0		2.20		2.20	V		
		4.5		3.15		3.15			
		5.5		3.85		3.85			
V_N	Negative Threshold Voltage	3.0	0.90		0.90		V		
		4.5	1.35		1.35				
		5.5	1.65		1.65				
V_H	Hysteresis Voltage	3.0	0.30	1.20	0.30	1.20	V		
		4.5	0.40	1.40	0.40	1.40			
		5.5	0.50	1.60	0.50	1.60			
V_{OH}	High Level Output Voltage	2.0	1.9	2.0	1.9		V	$V_{IN} = V_{IL}$	$I_{OH} = -50 \mu\text{A}$
		3.0	2.9	3.0	2.9				
		4.5	4.4	4.5	4.4		V		$I_{OH} = -4 \text{ mA}$ $I_{OH} = -8 \text{ mA}$
		3.0	2.58		2.48				
		4.5	3.94		3.80				
		V_{OL}	Low Level Output Voltage	2.0		0.0	0.1		V
3.0				0.0	0.1				
4.5				0.0	0.1				
3.0				0.36	0.44		V		$I_{OL} = 4 \text{ mA}$ $I_{OL} = 8 \text{ mA}$
4.5				0.36	0.44				
I_{IN}	Input Leakage Current	0-5.5		±0.1		±1.0	μA	$V_{IN} = 5.5\text{V or GND}$	
I_{CC}	Quiescent Supply Current	5.5		2.0		20.0	μA	$V_{IN} = V_{CC} \text{ or GND}$	

DC Characteristics for 'VHC Family Devices

Symbol	Parameter	V _{CC}	74VHC		Units	Conditions
			T _A = 25°C			
			Typ	Limits		
*V _{OLP}	Quiet Output Maximum Dynamic V _{OL}	5.0	0.4	0.8	V	C _L = 50 pF
*V _{OLV}	Quiet Output Minimum Dynamic V _{OL}	5.0	-0.4	-0.8	V	C _L = 50 pF
*V _{IHD}	Minimum High Level Dynamic Input Voltage	5.0		3.5	V	C _L = 50 pF
*V _{ILD}	Maximum Low Level Dynamic Input Voltage	5.0		1.5	V	C _L = 50 pF

*Parameter guaranteed by design.

AC Electrical Characteristics

Symbol	Parameter	V _{CC}	74VHC			74VHC		Units	Conditions
			T _A = 25°C			T _A = -40°C to +85°C			
			Min	Typ	Max	Min	Max		
t _{PLH}	Propagation Delay Time	3.3 ± 0.3	8.3	12.8	1.0	15.0	ns	C _L = 15 pF	
t _{PHL}			10.8	16.3	1.0	18.5		C _L = 50 pF	
		5.0 ± 0.5	5.5	8.6	1.0	10.0	ns	C _L = 15 pF	
			7.0	10.6	1.0	12.0		C _L = 50 pF	
C _{IN}	Input Capacitance		4	10		10	pF	V _{CC} = Open	
C _{PD}	Power Dissipation Capacitance		21				pF	(Note 1)	

Note 1: C_{PD} is defined as the value of the internal equivalent capacitance which is calculated from the operating current consumption without load. Average operating current can be obtained by the equation:

$$I_{CC}(\text{Opr}) = C_{PD} \cdot V_{CC} \cdot f_{IN} + I_{CC}/6 \text{ (per Gate)}$$

Ordering Information

The device number is used to form part of a simplified purchasing code, where the package type and temperature range are defined as follows:

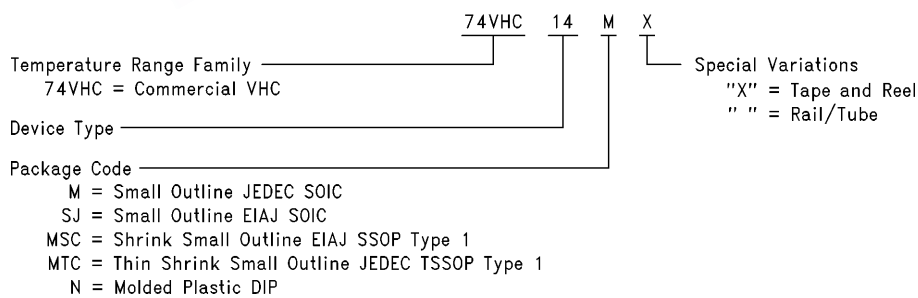

TL/F/11617-3

Physical Dimensions inches (millimeters)

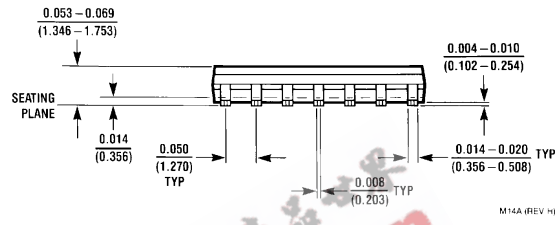
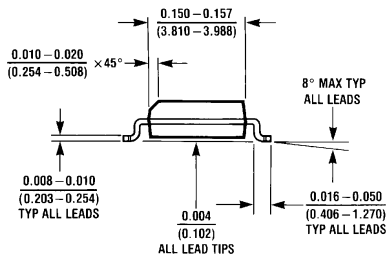
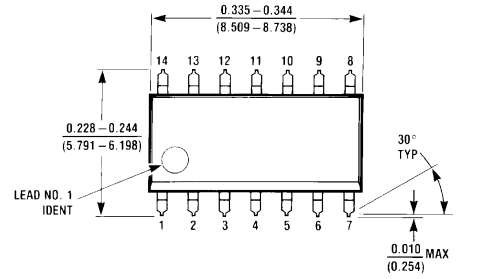

14-Lead Small Outline Integrated Circuit—JEDEC (M)
NS Package Number M14A

M14A (REV H)

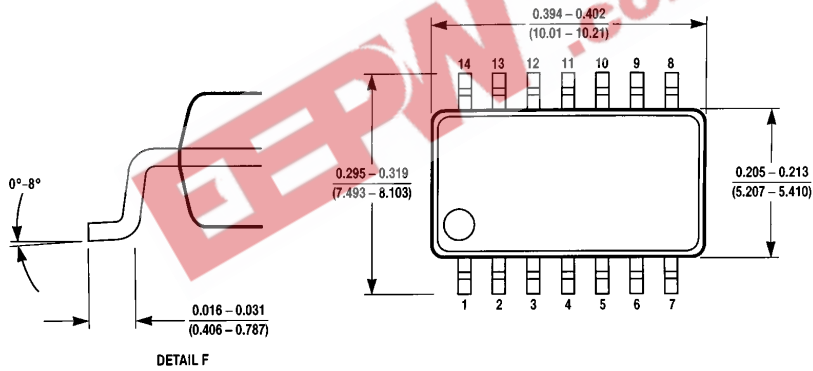

DETAIL F

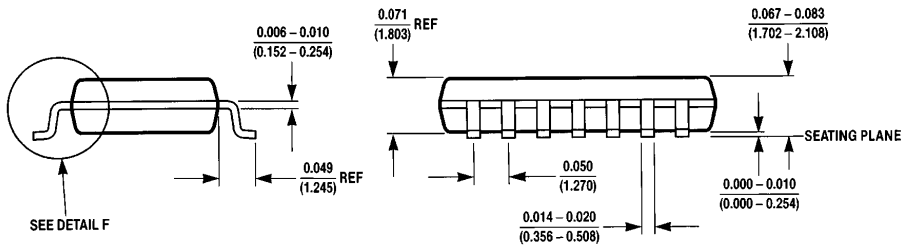

SEE DETAIL F

14-Lead Small Outline Package—EIAJ (SJ)
NS Package Number M14D

M14D (REV A)

Physical Dimensions inches (millimeters) (Continued)

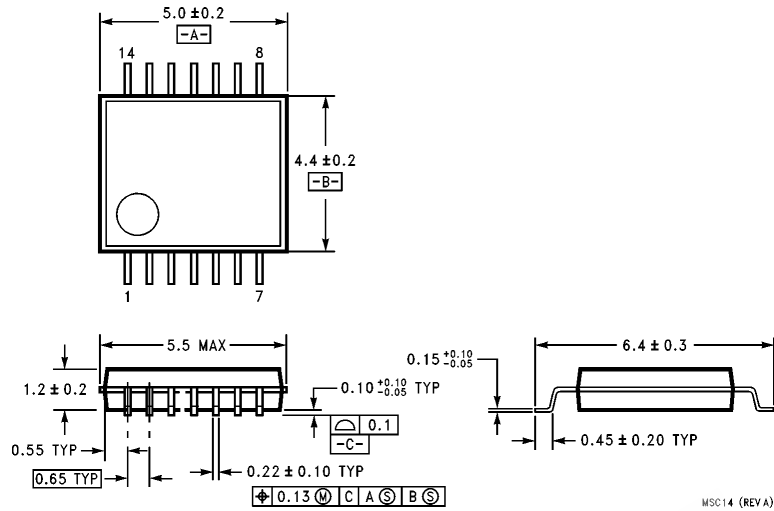

MSC14 (REV A)

14-Lead Plastic EIAJ SSOP Type 1 (MSC)
NS Package Number MSC14

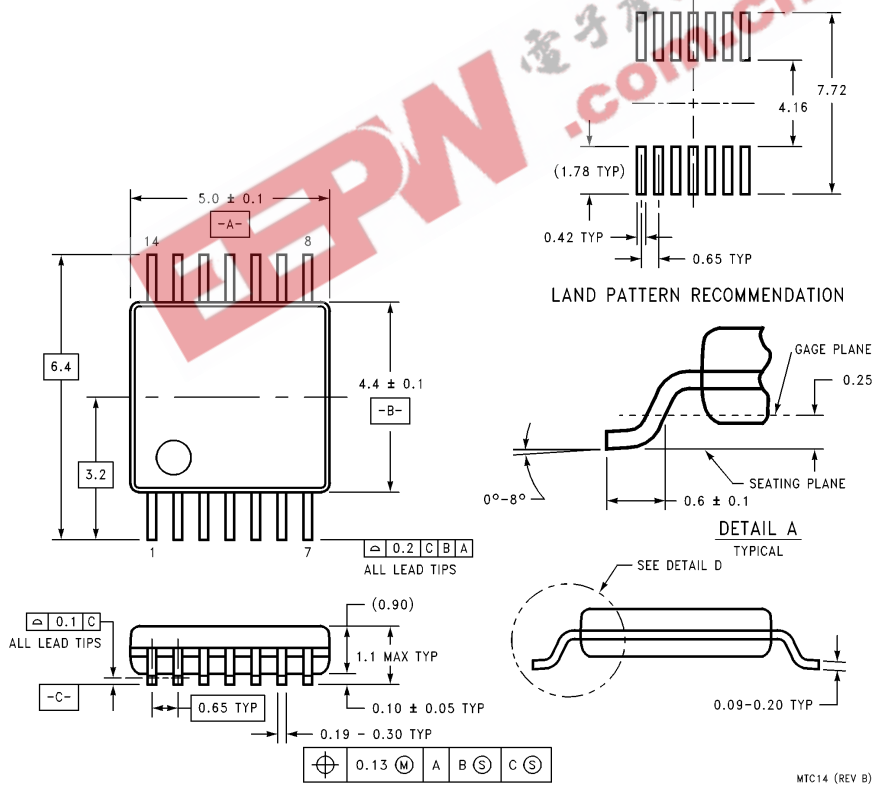

MTC14 (REV B)

14-Lead Molded JEDEC Type 1 (TSSOP)
NS Package Number MTC14

Physical Dimensions inches (millimeters) (Continued)

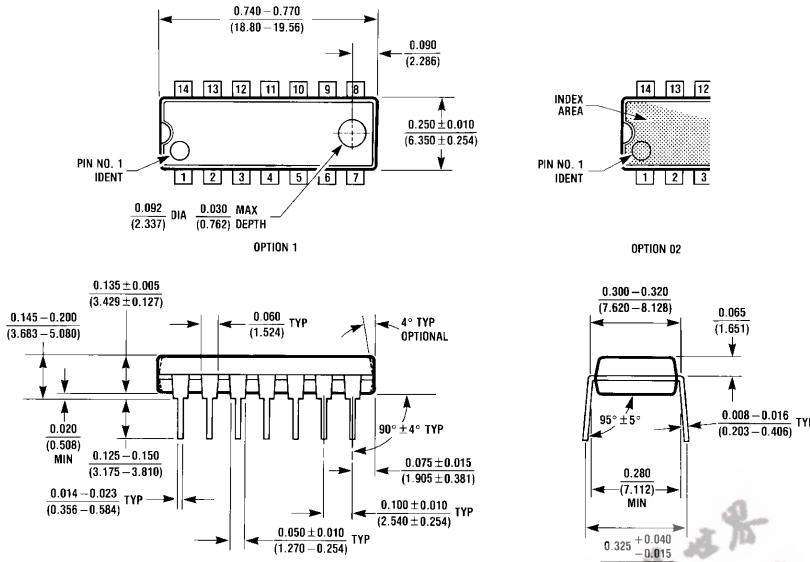

**14-Lead Molded DIP
NS Package Number N14A**

LIFE SUPPORT POLICY

NATIONAL'S PRODUCTS ARE NOT AUTHORIZED FOR USE AS CRITICAL COMPONENTS IN LIFE SUPPORT DEVICES OR SYSTEMS WITHOUT THE EXPRESS WRITTEN APPROVAL OF THE PRESIDENT OF NATIONAL SEMICONDUCTOR CORPORATION. As used herein:

1. Life support devices or systems are devices or systems which, (a) are intended for surgical implant into the body, or (b) support or sustain life, and whose failure to perform, when properly used in accordance with instructions for use provided in the labeling, can be reasonably expected to result in a significant injury to the user.
2. A critical component is any component of a life support device or system whose failure to perform can be reasonably expected to cause the failure of the life support device or system, or to affect its safety or effectiveness.

 <p>National Semiconductor Corporation 1111 West Bardin Road Arlington, TX 76017 Tel: 1(800) 272-9959 Fax: 1(800) 737-7018</p>	<p>National Semiconductor Europe Fax: (+49) 0-180-530 85 86 Email: cnjwge@levm2.nsc.com Deutsch Tel: (+49) 0-180-530 85 85 English Tel: (+49) 0-180-532 78 32 Français Tel: (+49) 0-180-532 93 58 Italiano Tel: (+49) 0-180-534 16 80</p>	<p>National Semiconductor Hong Kong Ltd. 13th Floor, Straight Block, Ocean Centre, 5 Canton Rd. Tsimshatsui, Kowloon Hong Kong Tel: (852) 2737-1600 Fax: (852) 2736-9960</p>	<p>National Semiconductor Japan Ltd. Tel: 81-043-299-2309 Fax: 81-043-299-2408</p>
--	--	---	---

National does not assume any responsibility for use of any circuitry described, no circuit patent licenses are implied and National reserves the right at any time without notice to change said circuitry and specifications.