

54F/74F2244

Octal Buffer/Line Driver with 25Ω Series Resistors in Outputs

General Description

The 'F2244 is an octal buffer/line driver designed to drive the capacitive inputs of MOS memory drivers, address drivers, clock drivers and bus-oriented transmitters/receivers.

The 25Ω series resistors in the outputs reduce ringing and eliminate the need for external resistors.

Features

- TRI-STATE® outputs drive bus lines or buffer memory address registers
- 12 mA source current
- 25Ω series resistors in outputs eliminate the need for external resistors.
- Designed to drive the capacitive inputs of MOS devices
- Guaranteed 4000V minimum ESD protection

Commercial	Military	Package Number	Package Description
74F2244PC		N20B	20-Lead (0.300" Wide) Molded Dual-In-Line
	54F2244DM (Note 2)	J20A	20-Lead Ceramic Dual-In-Line
74F2244SC (Note 1)		M20B	20-Lead (0.300" Wide) Molded Small Outline JEDEC
74F2244MSA (Note 1)		MSA20	20-Lead Molded Shrink Small Outline EIAJ Type II
	54F2244FM (Note 2)	W20A	20-Lead Cerpak
	54F2244LM (Note 2)	E20A	20-Lead Ceramic Leadless Chip Carrier, Type C

Note 1: Devices also available in 13" reel. Use suffix = SCX and MSAX.

Note 2: Military grade device with environmental and burn-in processing. Use suffix = DMQB, FMQB and LMQB.

Connection Diagrams

Pin Assignment for LCC

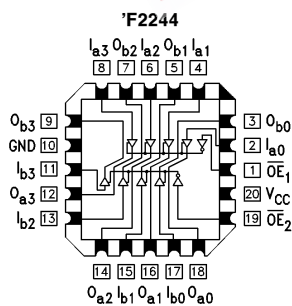

TL/F/9499-3

Pin Assignment for DIP, SOIC and SSOP

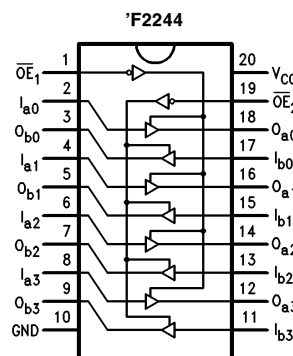

TL/F/9499-4

TRI-STATE® is a registered trademark of National Semiconductor Corporation.

Logic Symbol

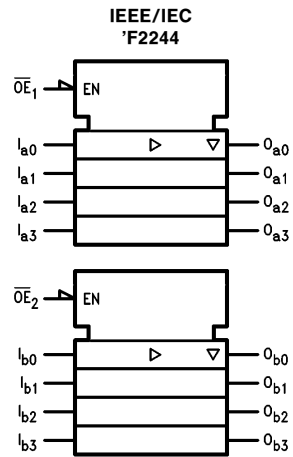

TL/F/9499-6

Unit Loading/Fan Out

Pin Names	Description	54F/74F	
		U.L. HIGH/LOW	Input I_{IH}/I_{IL} Output I_{OH}/I_{OL}
$\overline{OE}_1, \overline{OE}_2$	TRI-STATE Output Enable Input (Active LOW)	1.0/1.667	20 μ A/ -1 mA
OE_2	TRI-STATE Output Enable Input (Active HIGH)	1.0/1.667	20 μ A/ -1 mA
I_{an}, I_{bn}	Inputs	1.0/2.667*	20 μ A/ -1.6 mA
O_{an}, O_{bn}	Outputs	750/20	-15 mA/12 mA

*Worst-case 'F2244 disabled

Truth Table

'F2244

\overline{OE}_1	I_{an}	O_{an}	\overline{OE}_2	I_{bn}	O_{bn}
H	X	Z	H	X	Z
L	H	H	L	H	H
L	L	L	L	L	L

H = HIGH Voltage Level
L = LOW Voltage Level
X = Immaterial
Z = High Impedance

Absolute Maximum Ratings (Note 1)

If Military/Aerospace specified devices are required, please contact the National Semiconductor Sales Office/Distributors for availability and specifications.

Storage Temperature	-65°C to +150°C
Ambient Temperature under Bias	-55°C to +125°C
Junction Temperature under Bias	-55°C to +175°C
Plastic	-55°C to +150°C
V _{CC} Pin Potential to Ground Pin	-0.5V to +7.0V
Input Voltage (Note 2)	-0.5V to +7.0V
Input Current (Note 2)	-30 mA to +5.0 mA
Voltage Applied to Output in HIGH State (with V _{CC} = 0V)	
Standard Output	-0.5V to V _{CC}
TRI-STATE Output	-0.5V to +5.5V
Current Applied to Output in LOW State (Max)	twice the rated I _{OL} (mA)
ESD Last Passing Voltage (Min)	4000V

Note 1: Absolute maximum ratings are values beyond which the device may be damaged or have its useful life impaired. Functional operation under these conditions is not implied.

Note 2: Either voltage limit or current limit is sufficient to protect inputs.

Recommended Operating Conditions

Free Air Ambient Temperature	
Military	-55°C to +125°C
Commercial	0°C to +70°C
Supply Voltage	
Military	+4.5V to +5.5V
Commercial	+4.5V to +5.5V

DC Electrical Characteristics

Symbol	Parameter	54F/74F			Units	V _{CC}	Conditions
		Min	Typ	Max			
V _{IH}	Input HIGH Voltage	2.0			V		Recognized as a HIGH Signal
V _{IL}	Input LOW Voltage			0.8	V		Recognized as a LOW Signal
V _{CD}	Input Clamp Diode Voltage			-1.2	V	Min	I _{IN} = -18 mA
V _{OH}	Output HIGH Voltage	54F 10% V _{CC} 54F 10% V _{CC} 74F 10% V _{CC} 74F 10% V _{CC} 74F 5% V _{CC}	2.4 2.0 2.4 2.0 2.7		V	Min	I _{OH} = -3 mA I _{OH} = -12 mA I _{OH} = -3 mA I _{OH} = -15 mA I _{OH} = -3 mA
V _{OL}	Output LOW Voltage		0.50 0.75		V	Min	I _{OL} = 1 mA I _{OL} = 12 mA
I _{IH}	Input HIGH Current	54F 74F		20.0 5.0	μA	Max	V _{IN} = 2.7V
I _{BVI}	Input HIGH Current Breakdown Test	54F 74F		100 7.0	μA	Max	V _{IN} = 7.0V
I _{CEX}	Output HIGH Leakage Current	54F 74F		250 50	μA	Max	V _{OUT} = V _{CC}
V _{ID}	Input Leakage Test	74F	4.75		V	0.0	I _{ID} = 1.9 μA All other pins grounded
I _{OD}	Output Leakage Circuit Current	74F		3.75	μA	0.0	V _{IOD} = 150 mV All other pins grounded
I _{IL}	Input LOW Current			-1.0 -1.6	mA	Max	V _{IN} = 0.5V ($\overline{OE}_1, \overline{OE}_2, OE_2$) V _{IN} = 0.5V (I _n)
I _{OZH}	Output Leakage Current			50	μA	Max	V _{OUT} = 2.7V
I _{OZL}	Output Leakage Current			-50	μA	Max	V _{OUT} = 0.5V
I _{OS}	Output Short-Circuit Current		-100	-225	mA	Max	V _{OUT} = 0V
I _{CCH}	Power Supply Current		40	60	mA	Max	V _O = HIGH
I _{CCL}	Power Supply Current		60	90	mA	Max	V _O = LOW
I _{CCZ}	Power Supply Current		60	90	mA	Max	V _O = HIGH Z

AC Electrical Characteristics

Symbol	Parameter	74F			54F		74F		Units
		T _A = +25°C V _{CC} = +5.0V C _L = 50 pF			T _A , V _{CC} = Mil C _L = 50 pF		T _A , V _{CC} = Com C _L = 50 pF		
		Min	Typ	Max	Min	Max	Min	Max	
t _{PLH}	Propagation Delay	1.5		7.0	2.0	6.5	1.5	7.0	ns
t _{PHL}	Data to Output	2.5		8.0	2.0	7.0	2.0	8.0	
t _{PZH}	Output Enable Time	1.5		9.0	2.0	7.0	1.0	9.5	ns
t _{PZL}		2.5		11.5	2.0	8.5	2.5	12.0	
t _{PHZ}	Output Disable Time	1.5		9.0	2.0	7.0	1.0	9.5	
t _{PLZ}		1.5		8.5	2.0	7.5	1.5	9.5	

Ordering Information

The device number is used to form part of a simplified purchasing code where a package type and temperature range are defined as follows:

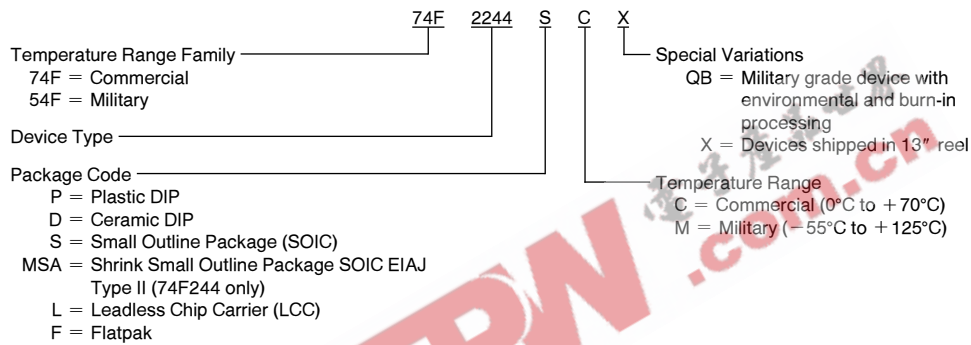

EEPW 电子产品世界
.com.cn

Physical Dimensions inches (millimeters)

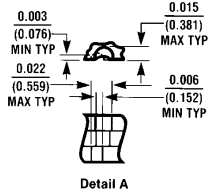
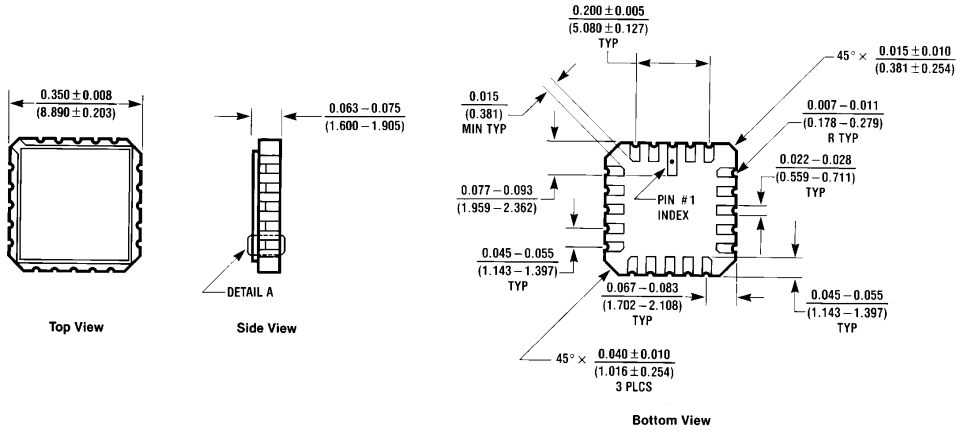

20-Lead Ceramic Leadless Chip Carrier, Type C (L)
NS Package Number E20A

E20A (REV D)

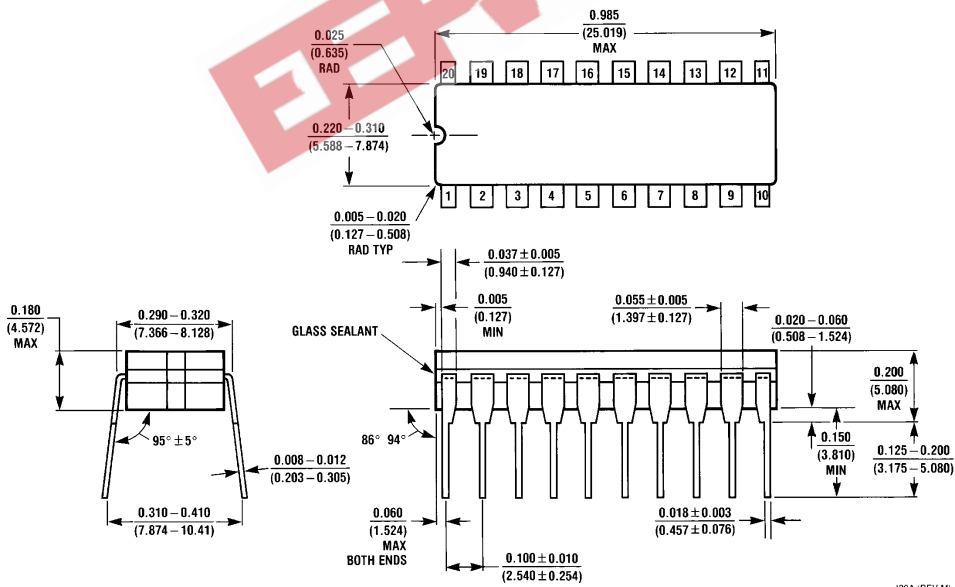

20-Lead Ceramic Dual-In-Line Package (D)
NS Package Number J20A

J20A (REV M)

Physical Dimensions inches (millimeters) (Continued)

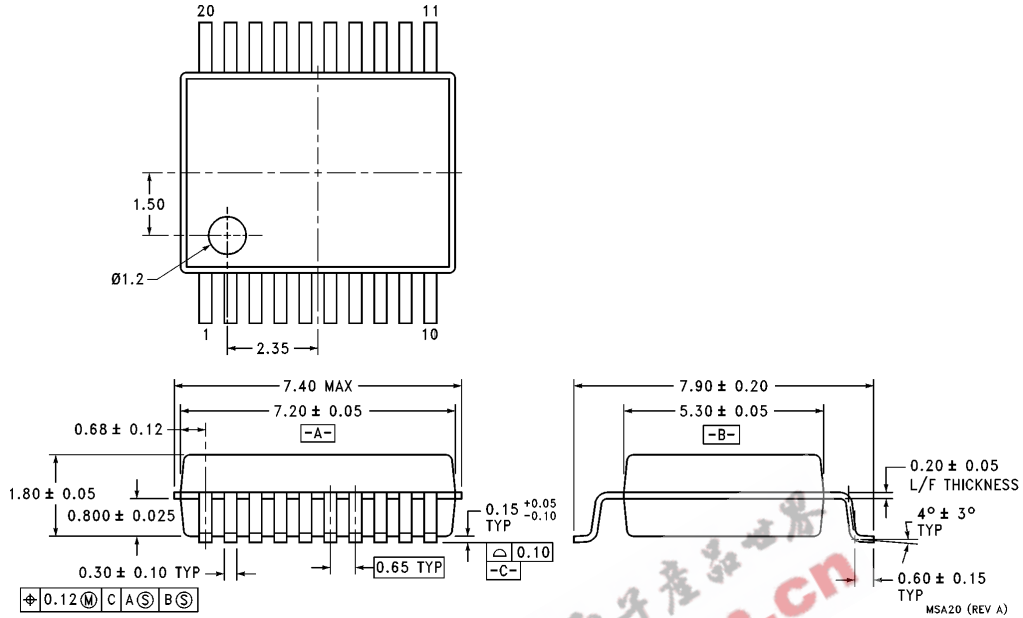

20-Lead Molded Shrink Small Outline Package, EIAJ Type II (MSA)
NS Package Number MSA20

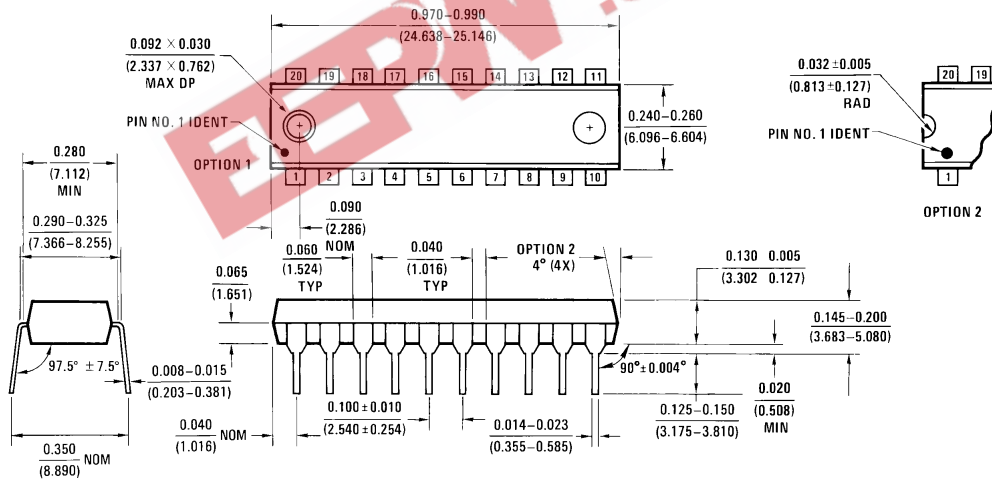

20-Lead (0.300" Wide) Molded Dual-In-Line Package (P)
NS Package Number N20B

