

HD74LS162A • Synchronous Decade Counters (synchronous clear)

This synchronous decade counter features an internal carry look-ahead for application in high-speed counting designs. Synchronous operation is provided by having all flip-flops clocked simultaneously so that the outputs change coincident with each other when so instructed by the count-enable inputs and internal gating. This mode of operation eliminates the output counting spikes that are normally associated with asynchronous (ripple clock) counters. A buffered clock input triggers the four flip-flops on the rising (positive-going) edge of the clock input waveform. This counter is fully programmable; that is, the outputs may be preset to either level. As presetting is synchronous, setting up a low level at the load input disables the counter and causes the outputs to agree with the setup data after the next clock pulse regardless of the levels of the enable inputs. Low-to-high transitions at the load input should be avoided when the clock is low if the enable inputs are high at or before the transition. The clear function is synchronous and a low level at the clear input sets all four of the flip-flop outputs low after the next clock pulse, regardless of the levels of the enable inputs. This synchronous clear allows the count length to be modified easily as decoding the maximum count desired can be accomplished with one external NAND gate. The gate output is connected to the clear input to synchronously clear the counter to LLLL. Low-to-high transitions at the clear input should be avoided when the clock is low if the enable and load inputs are high at or before the transition. The carry look-ahead circuitry provides for cascading counters for n-bit synchronous applications without additional gating. Instrumental in accomplishing this function are two count-enable inputs and a ripple carry output. Both count-enable inputs (P and T) must be high to count, and input T is fed forward to enable the ripple carry output. The ripple carry output thus enabled will produce a high-level output pulse with a duration approximately equal to the high-level portion of the Q_A output. This high-level overflow ripple carry pulse can be used to enable successive cascaded stages. High-to-low-level transitions at the enable P or T inputs should occur only when the clock input is high.

■ PIN ARRANGEMENT

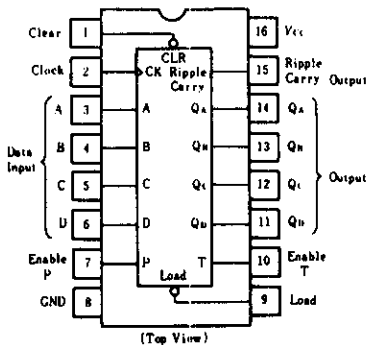

■ BLOCK DIAGRAM

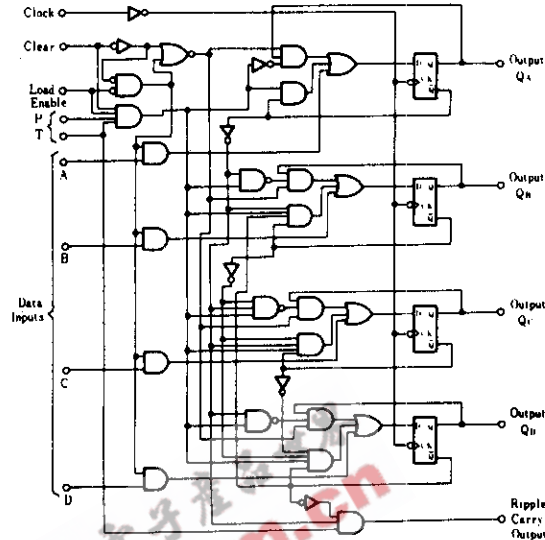

■ TYPICAL CLEAR, PRESET, AND INHIBIT SEQUENCE

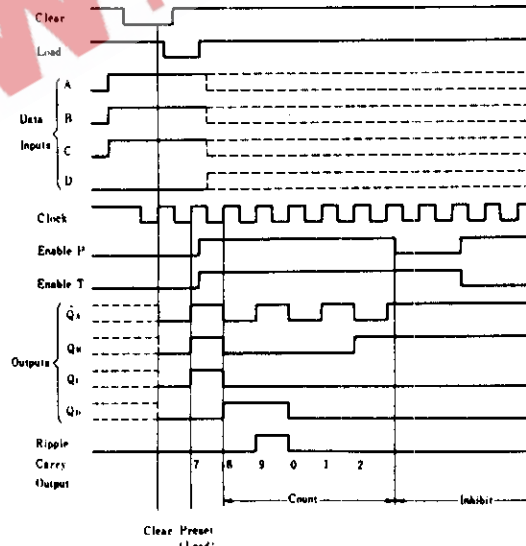

■ RECOMMENDED OPERATING CONDITIONS

| Item | Symbol | min | typ | max | Unit |
|-------------------|-------------|-----|-----|-----|------|
| Clock frequency | f_{clock} | 0 | — | 25 | MHz |
| Clock pulse width | $t_w(CK)$ | 25 | — | — | ns |
| Clear pulse width | $t_w(CLR)$ | 20 | — | — | ns |
| Setup time | A, B, C, D | 20 | — | — | ns |
| | Enable P, T | 20 | — | — | ns |
| | Load | 20 | — | — | ns |
| | Clear | 20 | — | — | ns |
| Hold time | t_h | 3 | — | — | ns |

HD74LS162A

■TIMING DEFINITION

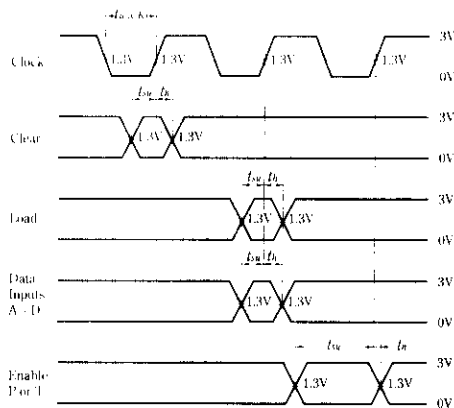

■ELECTRICAL CHARACTERISTICS (T_a = -20 ~ +75°C)

| Item | Symbol | Test Conditions | min | typ* | max | Unit | |
|------------------------------|--|---|------|------|------|------|----|
| Input voltage | V _{IH} | | 2.0 | — | — | V | |
| | V _{IL} | | — | — | 0.8 | V | |
| Output voltage | V _{OH} | V _{CC} = 4.75V, V _{IH} = 2V, V _{IL} = 0.8V, I _{OH} = -400μA | 2.7 | — | — | V | |
| | V _{OL} | V _{CC} = 4.75V, V _{IH} = 2V, I _{OL} = 4mA | — | — | 0.4 | V | |
| | | V _{CC} = 4.75V, V _{IH} = 2V, I _{OL} = 8mA | — | — | 0.5 | | |
| Input current | Data, Enable P | V _{CC} = 5.25V, V _I = 2.7V | — | — | 20 | μA | |
| | Load, Clock, Enable T | | — | — | 40 | | |
| | Clear | | — | — | 40 | | |
| | Data, Enable P | | — | — | -0.4 | | mA |
| | Load, Clock, Enable T | | — | — | -0.8 | | |
| Clear | — | — | -0.8 | | | | |
| Data, Enable P | V _{CC} = 5.25V, V _I = 7V | — | — | 0.1 | mA | | |
| Load, Clock, Enable T | | — | — | 0.2 | | | |
| Clear | | — | — | 0.2 | | | |
| Short-circuit output current | I _{OS} | V _{CC} = 5.25V | -20 | — | 100 | mA | |
| Supply current** | I _{CCH} | V _{CC} = 5.25V | — | 18 | 31 | mA | |
| | I _{CLL} | V _{CC} = 5.25V | — | 19 | 32 | mA | |
| Input clamp voltage | V _{IK} | V _{CC} = 4.75V, I _{IK} = 18mA | — | — | 1.5 | V | |

* V_{CC} = 5V, T_a = 25°C

** I_{CCH} is measured with the load input high, then again with the load input low, with all other inputs high and all outputs open. I_{CLL} is measured with the clock input high, then again with the clock input low, with all other inputs low and all outputs open.

■SWITCHING CHARACTERISTICS (V_{CC} = 5V, T_a = 25°C)

| Item | Symbol | Inputs | Outputs | Test Conditions | min | typ | max | Unit | |
|-------------------------|------------------|---------------------------------|---------------------------------|---|--------------|-----|-----|------|----|
| Maximum clock frequency | f _{max} | Clock | Q _A ~ Q _D | C _L = 15pF, R _L = 2kΩ | 25 | 32 | — | MHz | |
| Propagation delay time | t _{PLH} | Clock | Ripple | | — | 20 | 35 | ns | |
| | | | Carry | | — | 18 | 35 | ns | |
| | t _{PLH} | Clock | Q _A ~ Q _D | | (Load = "H") | — | 13 | 24 | ns |
| | | | | | (Load = "L") | — | 18 | 27 | ns |
| | t _{PHL} | Clock | Q _A ~ Q _D | | (Load = "H") | — | 13 | 24 | ns |
| | | | | | (Load = "L") | — | 18 | 27 | ns |
| | t _{PLH} | Enable T | Ripple | | Carry | — | 9 | 14 | ns |
| | | | | | | — | 9 | 14 | ns |
| t _{PHL} | Clear | Q _A ~ Q _D | — | | 20 | 28 | ns | | |

HD74LS162A

TESTING METHOD

1) Test Circuit

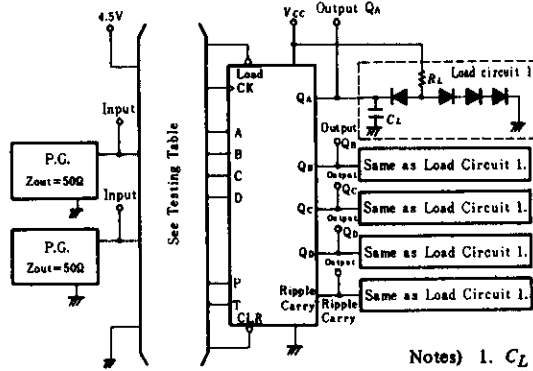

- Notes) 1. C_L includes probe and jig capacitance.
2. All diodes are 1S2074 (H)

2) Testing Table

| Item | From input to output | Inputs | | | | | | | | | | Outputs | | | | |
|-----------|-----------------------|--------|------|--------|------|-------|------|------|------|------|------|---------|-----|-----|--------------|-----|
| | | Clear | Load | Enable | | Clock | Data | | | | QA | QB | QC | QD | Ripple Carry | |
| | | | | P | T | | A | B | C | D | | | | | | |
| f_{max} | | 4.5V | 4.5V | 4.5V | 4.5V | IN | GND | GND | GND | GND | GND | OUT | OUT | OUT | OUT | OUT |
| t_{PLH} | CK→Ripple Carry | 4.5V | 4.5V | 4.5V | 4.5V | IN | GND | GND | GND | GND | GND | — | — | — | — | OUT |
| | CK→Q | 4.5V | 4.5V | 4.5V | 4.5V | IN | GND | GND | GND | GND | GND | OUT | OUT | OUT | OUT | — |
| t_{PHL} | CK→Q | 4.5V | GND | GND | GND | IN | IN* | IN* | IN* | IN* | IN* | OUT | OUT | OUT | OUT | — |
| | Enable T→Ripple Carry | 4.5V | GND | 4.5V | IN | IN** | 4.5V | GND | GND | 4.5V | 4.5V | — | — | — | — | OUT |
| | Clear→Q | IN | GND | GND | GND | IN** | 4.5V | 4.5V | 4.5V | 4.5V | 4.5V | OUT | OUT | OUT | OUT | — |

* Measuring outputs correspond to this condition, each outputs (Q_A , Q_B , Q_C , and Q_D) must not be over the following rate, "H", "L", "L", and "H".

** For initialized

3) Waveform-1 f_{max} , t_{PLH} , t_{PHL} (Clock→Q, Ripple Carry)

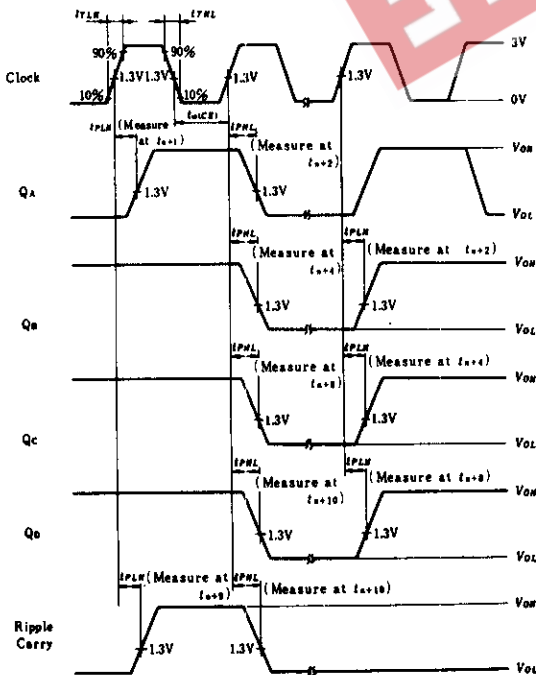

Waveform-2 t_{PLH} , t_{PHL} (Clock→Q)

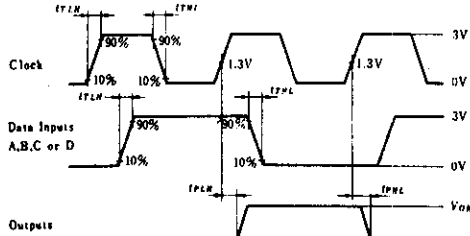

Notes) Input pulse: $t_{TLH} \leq 15ns$, $t_{THL} \leq 6ns$, Clock input: $PRR = 1MHz$, duty cycle 50%, Data input: $PRR = 500kHz$, duty cycle 50%

Waveform-3 t_{PLH} , t_{PHL} (Enable T→Ripple Carry)

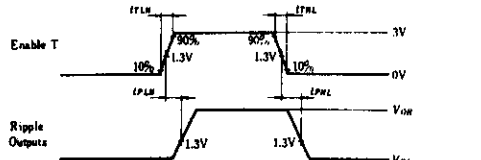

Note) Input pulse: $t_{TLH} \leq 15ns$, $t_{THL} \leq 6ns$, $PRR = 1MHz$

Waveform-4 t_{PHL} (Clear→Q)

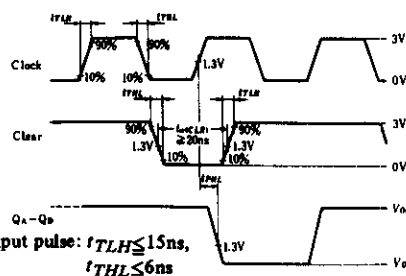

Note) Input pulse: $t_{TLH} \leq 15ns$, $t_{THL} \leq 6ns$

- Notes) 1. Clock input pulse; $t_{TLH} \leq 15ns$, $t_{THL} \leq 6ns$, $PRR = 1MHz$, duty cycle=50% and; for f_{max} , $t_{TLH} = t_{THL} \leq 2.5ns$.
2. t_n is reference bit time when all outputs are low.

Unit: mm

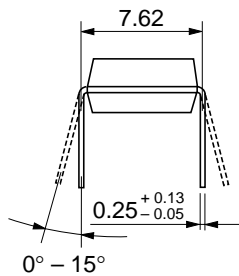
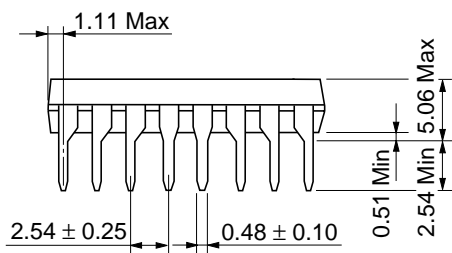
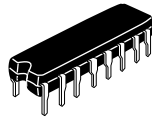
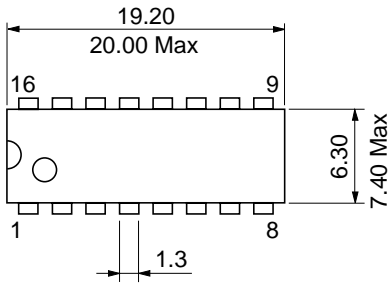

| | |
|--------------------------|----------|
| Hitachi Code | DP-16 |
| JEDEC | Conforms |
| EIAJ | Conforms |
| Weight (reference value) | 1.07 g |

Unit: mm

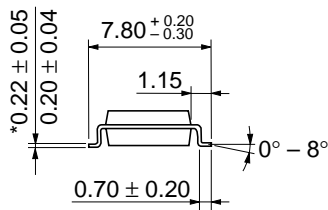
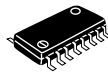
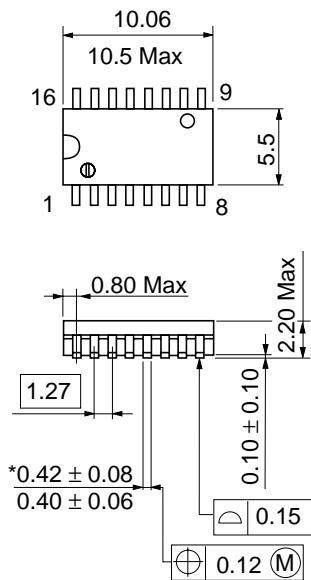

| | |
|--------------------------|----------|
| Hitachi Code | FP-16DA |
| JEDEC | — |
| EIAJ | Conforms |
| Weight (reference value) | 0.24 g |

*Dimension including the plating thickness
Base material dimension

Unit: mm

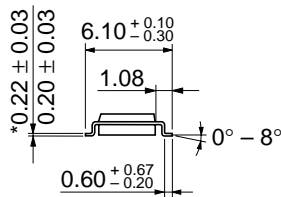
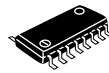
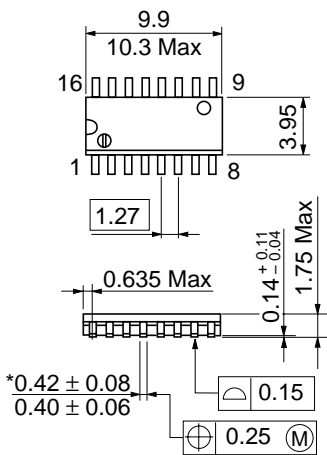

*Dimension including the plating thickness
Base material dimension

| | |
|--------------------------|----------|
| Hitachi Code | FP-16DN |
| JEDEC | Conforms |
| EIAJ | Conforms |
| Weight (reference value) | 0.15 g |

Cautions

1. Hitachi neither warrants nor grants licenses of any rights of Hitachi's or any third party's patent, copyright, trademark, or other intellectual property rights for information contained in this document. Hitachi bears no responsibility for problems that may arise with third party's rights, including intellectual property rights, in connection with use of the information contained in this document.
2. Products and product specifications may be subject to change without notice. Confirm that you have received the latest product standards or specifications before final design, purchase or use.
3. Hitachi makes every attempt to ensure that its products are of high quality and reliability. However, contact Hitachi's sales office before using the product in an application that demands especially high quality and reliability or where its failure or malfunction may directly threaten human life or cause risk of bodily injury, such as aerospace, aeronautics, nuclear power, combustion control, transportation, traffic, safety equipment or medical equipment for life support.
4. Design your application so that the product is used within the ranges guaranteed by Hitachi particularly for maximum rating, operating supply voltage range, heat radiation characteristics, installation conditions and other characteristics. Hitachi bears no responsibility for failure or damage when used beyond the guaranteed ranges. Even within the guaranteed ranges, consider normally foreseeable failure rates or failure modes in semiconductor devices and employ systemic measures such as fail-safes, so that the equipment incorporating Hitachi product does not cause bodily injury, fire or other consequential damage due to operation of the Hitachi product.
5. This product is not designed to be radiation resistant.
6. No one is permitted to reproduce or duplicate, in any form, the whole or part of this document without written approval from Hitachi.
7. Contact Hitachi's sales office for any questions regarding this document or Hitachi semiconductor products.

HITACHI

Hitachi, Ltd.

Semiconductor & Integrated Circuits.
Nippon Bldg., 2-6-2, Ohte-machi, Chiyoda-ku, Tokyo 100-0004, Japan
Tel: Tokyo (03) 3270-2111 Fax: (03) 3270-5109

URL North America : <http://semiconductor.hitachi.com/>
 Europe : <http://www.hitachi-eu.com/hel/ecg>
 Asia (Singapore) : <http://www.has.hitachi.com.sg/grp3/sicd/index.htm>
 Asia (Taiwan) : http://www.hitachi.com.tw/E/Product/SICD_Frame.htm
 Asia (HongKong) : <http://www.hitachi.com.hk/eng/bo/grp3/index.htm>
 Japan : <http://www.hitachi.co.jp/Sicd/indx.htm>

For further information write to:

Hitachi Semiconductor
(America) Inc.
179 East Tasman Drive,
San Jose, CA 95134
Tel: <1> (408) 433-1990
Fax: <1> (408) 433-0223

Hitachi Europe GmbH
Electronic components Group
Dornacher StraÙe 3
D-85622 Feldkirchen, Munich
Germany
Tel: <49> (89) 9 9180-0
Fax: <49> (89) 9 29 30 00

Hitachi Europe Ltd.
Electronic Components Group.
Whitebrook Park
Lower Cookham Road
Maidenhead
Berkshire SL6 8YA, United Kingdom
Tel: <44> (1628) 585000
Fax: <44> (1628) 778322

Hitachi Asia Pte. Ltd.
16 Collyer Quay #20-00
Hitachi Tower
Singapore 049318
Tel: 535-2100
Fax: 535-1533

Hitachi Asia Ltd.
Taipei Branch Office
3F, Hung Kuo Building, No.167,
Tun-Hwa North Road, Taipei (105)
Tel: <886> (2) 2718-3666
Fax: <886> (2) 2718-8180

Hitachi Asia (Hong Kong) Ltd.
Group III (Electronic Components)
7/F., North Tower, World Finance Centre,
Harbour City, Canton Road, Tsim Sha Tsui,
Kowloon, Hong Kong
Tel: <852> (2) 735 9218
Fax: <852> (2) 730 0281
Telex: 40815 HITEC HX

Copyright ' Hitachi, Ltd., 1999. All rights reserved. Printed in Japan.

HITACHI