

# DATA SHEET

EEPW 电子产品世界  
.com.cn

**74LV4316**

Quad bilateral switches

Product specification  
Supersedes data of 1994 Dec 01  
IC24 Data Handbook

1998 Jun 23

## Quad bilateral switches

## 74LV4316

## FEATURES

- Optimized for Low Voltage applications: 1.0V to 6.0V
- Accepts TTL input levels between  $V_{CC} = 2.7V$  and  $V_{CC} = 3.6V$
- Low typ "ON" resistance:  
80 $\Omega$  at  $V_{CC} - V_{EE} = 4.5V$   
120 $\Omega$  at  $V_{CC} - V_{EE} = 3.0V$   
295 $\Omega$  at  $V_{CC} - V_{EE} = 2.0V$
- Logic level translation: to enable 3V logic to communicate with  $\pm 3V$  analog signals
- Typical "break before make" built in
- Output capability: non-standard
- $I_{CC}$  category: MSI

## QUICK REFERENCE DATA

GND = 0 V;  $T_{amb} = 25^{\circ}C$ ;  $t_r = t_f \leq 2.5$  ns

SYMBOL	PARAMETER	CONDITIONS	TYPICAL	UNIT
$t_{PZH}/t_{PZL}$	Turn "ON" time: $\bar{E}$ to $V_{OS}$ nS to $V_{OS}$	$C_L = 15pF$ $R_L = 1K\Omega$ $V_{CC} = 3.3V$	19	ns
$t_{PHZ}/t_{PLZ}$	Turn "OFF" time: $\bar{E}$ to $V_{OS}$ nS to $V_{OS}$		20	ns
$C_I$	Input capacitance		3.5	pF
$C_{PD}$	Power dissipation capacitance per switch	Notes 1, 2	13	pF
$C_S$	Maximum switch capacitance		5	pF

## NOTES:

- $C_{PD}$  is used to determine the dynamic power dissipation ( $P_D$  in  $\mu W$ )  
 $P_D = C_{PD} \times V_{CC}^2 \times f_i + \sum (C_L \times V_{CC}^2 \times f_o)$  where:  
 $f_i$  = input frequency in MHz;  $C_L$  = output load capacity in pF;  
 $f_o$  = output frequency in MHz;  $V_{CC}$  = supply voltage in V;  
 $V_{CC}$  = supply voltage in V;  
 $\sum (C_L \times V_{CC}^2 \times f_o)$  = sum of the outputs.
- The condition is  $V_I = GND$  to  $V_{CC}$ .

## ORDERING INFORMATION

PACKAGES	TEMPERATURE RANGE	OUTSIDE NORTH AMERICA	NORTH AMERICA	PKG. DWG. #
16-Pin Plastic DIL	-40°C to +125°C	74LV4316 N	74LV4316 N	SOT38-4
16-Pin Plastic SO	-40°C to +125°C	74LV4316 D	74LV4316 D	SOT109-1
16-Pin Plastic SSOP Type II	-40°C to +125°C	74LV4316 DB	74LV4316 DB	SOT338-1
16-Pin Plastic TSSOP Type I	-40°C to +125°C	74LV4316 PW	74LV4316PW DH	SOT403-1

## PIN CONFIGURATION

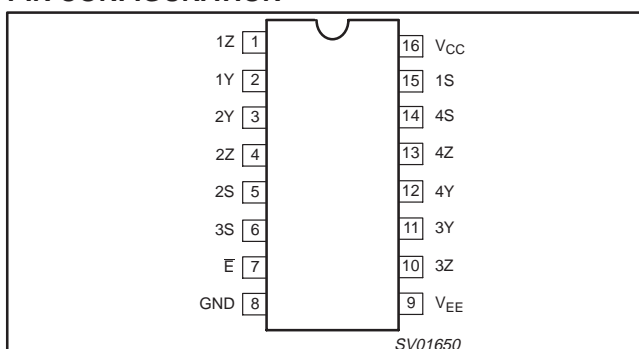

## PIN DESCRIPTION

PIN NUMBER	SYMBOL	FUNCTION
1, 4, 10, 13	1Z – 4Z	Independent inputs/outputs
2, 3, 11, 12	1Y – 4Y	Independent inputs/outputs
7	$\bar{E}$	Enable input (active LOW)
8	GND	Ground (0V)
9	$V_{EE}$	Negative supply voltage
15, 5, 6, 14	1S – 4S	Select inputs (active HIGH)
16	$V_{CC}$	Positive supply voltage

## DESCRIPTION

The 74LV4316 is a low-voltage CMOS device that is pin and function compatible with 74HC/HCT4316.

The 74LV4316 has four independent analog switches. Each switch has two input/output terminals (nY, nZ) and an active HIGH select input (nS). When the enable input ( $\bar{E}$ ) is HIGH, all four analog switches are turned off.

Current through a switch will not cause additional  $V_{CC}$  current provided the voltage at the terminals of the switch is maintained within the supply voltage range;  $V_{CC} > (V_Y, V_Z) > V_{EE}$ . Inputs nY and nZ are electrically equivalent terminals.  $V_{CC}$  and GND are the supply voltage pins for the digital control inputs ( $\bar{E}$  and nS). The  $V_{CC}$  to GND ranges are 1.0 to 6.0 V.

The analog inputs/outputs (nY and nZ) can swing between  $V_{CC}$  as a positive limit and  $V_{EE}$  as a negative limit.

$V_{CC} - V_{EE}$  may not exceed 6.0 V.

Quad bilateral switches

74LV4316

IEC LOGIC SYMBOL

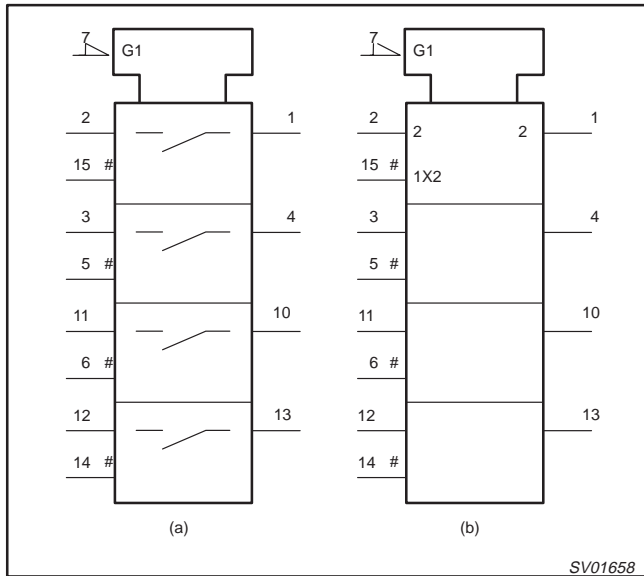

FUNCTIONAL DIAGRAM

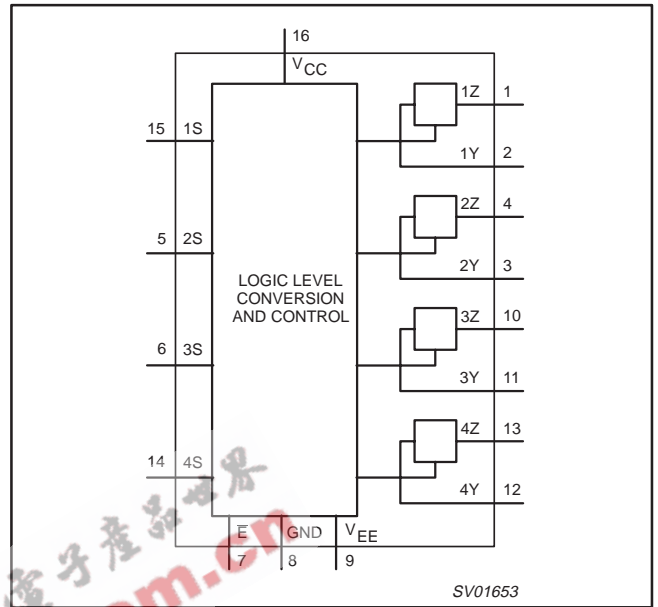

LOGIC SYMBOL

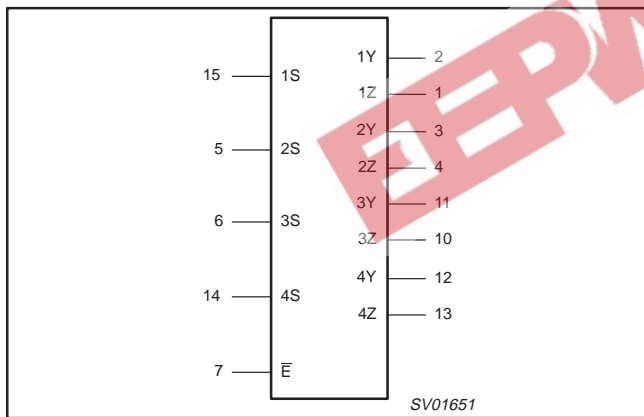

SCHEMATIC DIAGRAM (ONE SWITCH)

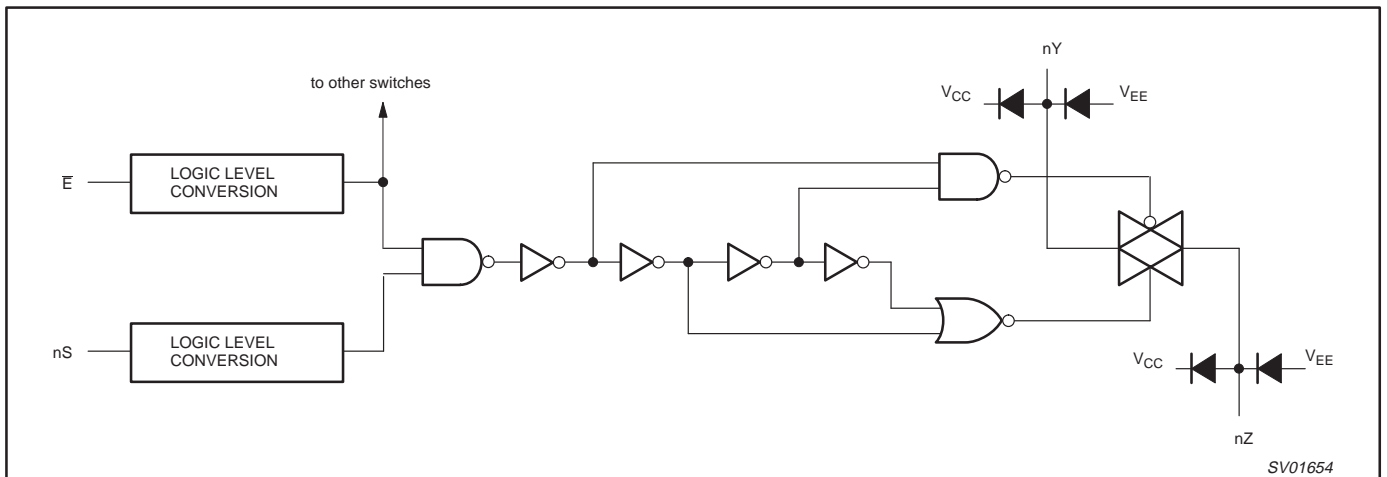

## Quad bilateral switches

74LV4316

## RECOMMENDED OPERATING CONDITIONS

SYMBOL	PARAMETER	CONDITIONS	MIN	TYP	MAX	UNIT
$V_{CC}$	DC supply voltage	See Note 1	1.0	3.3	6.0	V
$V_I$	Input voltage		0	–	$V_{CC}$	V
$V_O$	Output voltage		0	–	$V_{CC}$	V
$T_{amb}$	Operating ambient temperature range in free air	See DC and AC characteristics	–40 –40		+85 +125	°C
$t_r, t_f$	Input rise and fall times	$V_{CC} = 1.0V$ to $2.0V$ $V_{CC} = 2.0V$ to $2.7V$ $V_{CC} = 2.7V$ to $3.6V$ $V_{CC} = 3.6V$ to $5.5V$	– – – –	– – – –	500 200 100 50	ns/V

## NOTE:

- The LV is guaranteed to function down to  $V_{CC} = 1.0V$  (input levels GND or  $V_{CC}$ ); DC characteristics are guaranteed from  $V_{CC} = 1.2V$  to  $V_{CC} = 5.5V$ .

ABSOLUTE MAXIMUM RATINGS<sup>1, 2</sup>

In accordance with the Absolute Maximum Rating System (IEC 134).

Voltages are referenced to GND (ground = 0 V).

SYMBOL	PARAMETER	CONDITIONS	RATING	UNIT
$V_{CC}$	DC supply voltage		–0.5 to +7.0	V
$\pm I_{IK}$	DC input diode current	$V_I < -0.5$ or $V_I > V_{CC} + 0.5V$	20	mA
$\pm I_{OK}$	DC output diode current	$V_O < -0.5$ or $V_O > V_{CC} + 0.5V$	20	mA
$\pm I_O$	DC switch current	$-0.5V < V_O < V_{CC} + 0.5V$	25	mA
$T_{stg}$	Storage temperature range		–65 to +150	°C
$P_{TOT}$	Power dissipation per package – plastic DIL – plastic mini-pack (SO) – plastic shrink mini-pack (SSOP and TSSOP)	for temperature range: –40 to +125°C above +70°C derate linearly with 12 mW/K above +70°C derate linearly with 8 mW/K above +60°C derate linearly with 5.5 mW/K	750 500 400	mW

## NOTES:

- Stresses beyond those listed may cause permanent damage to the device. These are stress ratings only and functional operation of the device at these or any other conditions beyond those indicated under "recommended operating conditions" is not implied. Exposure to absolute-maximum-rated conditions for extended periods may affect device reliability.
- The input and output voltage ratings may be exceeded if the input and output current ratings are observed.

## Quad bilateral switches

74LV4316

**DC ELECTRICAL CHARACTERISTICS**

Over recommended operating conditions. Voltages are referenced to GND (ground = 0 V).

SYMBOL	PARAMETER	TEST CONDITIONS	LIMITS					UNIT
			-40°C to +85°C			-40°C to +125°C		
			MIN	TYP <sup>1</sup>	MAX	MIN	MAX	
$V_{IH}$	HIGH level Input voltage	$V_{CC} = 1.2\text{ V}$	0.90			0.90		V
		$V_{CC} = 2.0\text{ V}$	1.40			1.4		
		$V_{CC} = 2.7\text{ to }3.6\text{ V}$	2.00			2.0		
		$V_{CC} = 4.5\text{ V}$	3.15			3.15		
		$V_{CC} = 6.0\text{ V}$	4.20			4.20		
$V_{IL}$	LOW level Input voltage	$V_{CC} = 1.2\text{ V}$			0.30		0.30	V
		$V_{CC} = 2.0\text{ V}$			0.60		0.60	
		$V_{CC} = 2.7\text{ to }3.6\text{ V}$			0.80		0.80	
		$V_{CC} = 4.5\text{ V}$			1.35		1.35	
		$V_{CC} = 6.0\text{ V}$			1.80		1.80	
$\pm I_I$	Input leakage current	$V_{CC} = 3.6\text{ V}; V_I = V_{CC}\text{ or GND}$ $V_{CC} = 6.0\text{ V}; V_I = V_{CC}\text{ or GND}$			1.0 2.0		1.0 2.0	$\mu\text{A}$
$\pm I_S$	Analog switch OFF-state current per channel	$V_{CC} = 3.6\text{ V}; V_I = V_{IH}\text{ or }V_{IL}$ $V_{CC} = 6.0\text{ V}; V_I = V_{IH}\text{ or }V_{IL}$			1.0 2.0		1.0 2.0	$\mu\text{A}$
$\pm I_S$	Analog switch ON-state current per channel	$V_{CC} = 3.6\text{ V}; V_I = V_{IH}\text{ or }V_{IL}$ $V_{CC} = 6.0\text{ V}; V_I = V_{IH}\text{ or }V_{IL}$			1.0 2.0		1.0 2.0	$\mu\text{A}$
$I_{CC}$	Quiescent supply current	$V_{CC} = 3.6\text{ V}; V_I = V_{CC}\text{ or GND}; I_O = 0$ $V_{CC} = 6.0\text{ V}; V_I = V_{CC}\text{ or GND}; I_O = 0$			20 40		40 80	$\mu\text{A}$
$\Delta I_{CC}$	Additional quiescent supply current per input	$V_{CC} = 2.7\text{ V to }3.6\text{ V}; V_I = V_{CC} - 0.6\text{ V}$			500		850	$\mu\text{A}$
$R_{ON}$	ON-resistance (peak)	$V_{CC} = 1.2\text{ V}; V_I = V_{IH}\text{ or }V_{IL}$		295	–		–	$\Omega$
		$V_{CC} = 2.0\text{ V}; V_I = V_{IH}\text{ or }V_{IL}$		120	860		990	
		$V_{CC} = 2.7\text{ V}; V_I = V_{IH}\text{ or }V_{IL}$		110	300		360	
		$V_{CC} = 3.0\text{ to }3.6\text{ V}; V_I = V_{IH}\text{ or }V_{IL}$		80	270		325	
		$V_{CC} = 4.5\text{ V}; V_I = V_{IH}\text{ or }V_{IL}$		70	200		240	
		$V_{CC} = 6.0\text{ V}; V_I = V_{IH}\text{ or }V_{IL}$			180		215	
$R_{ON}$	ON-resistance (rail)	$V_{CC} = 1.2\text{ V}; V_I = V_{IH}\text{ or }V_{IL}$		225	–		–	$\Omega$
		$V_{CC} = 2.0\text{ V}; V_I = V_{IH}\text{ or }V_{IL}$		110	240		290	
		$V_{CC} = 2.7\text{ V}; V_I = V_{IH}\text{ or }V_{IL}$		85	150		180	
		$V_{CC} = 3.0\text{ to }3.6\text{ V}; V_I = V_{IH}\text{ or }V_{IL}$		55	135		180	
		$V_{CC} = 4.5\text{ V}; V_I = V_{IH}\text{ or }V_{IL}$		40	100		120	
		$V_{CC} = 6.0\text{ V}; V_I = V_{IH}\text{ or }V_{IL}$		35	90		110	
$R_{ON}$	ON-resistance (rail)	$V_{CC} = 1.2\text{ V}; V_I = V_{IH}\text{ or }V_{IL}$		250	–		–	$\Omega$
		$V_{CC} = 2.0\text{ V}; V_I = V_{IH}\text{ or }V_{IL}$		120	270		325	
		$V_{CC} = 2.7\text{ V}; V_I = V_{IH}\text{ or }V_{IL}$		75	170		205	
		$V_{CC} = 3.0\text{ to }3.6\text{ V}; V_I = V_{IH}\text{ or }V_{IL}$		60	155		180	
		$V_{CC} = 4.5\text{ V}; V_I = V_{IH}\text{ or }V_{IL}$		45	115		135	
		$V_{CC} = 6.0\text{ V}; V_I = V_{IH}\text{ or }V_{IL}$		40	105		120	
$\Delta R_{ON}$	Maximum variation of ON-resistance between any two channels	$V_{CC} = 1.2\text{ V}; V_I = V_{IH}\text{ or }V_{IL}$		–				$\Omega$
		$V_{CC} = 2.0\text{ V}; V_I = V_{IH}\text{ or }V_{IL}$		5				
		$V_{CC} = 2.7\text{ V}; V_I = V_{IH}\text{ or }V_{IL}$		4				
		$V_{CC} = 3.0\text{ to }3.6\text{ V}; V_I = V_{IH}\text{ or }V_{IL}$		4				
		$V_{CC} = 4.5\text{ V}; V_I = V_{IH}\text{ or }V_{IL}$		3				
		$V_{CC} = 6.0\text{ V}; V_I = V_{IH}\text{ or }V_{IL}$		2				

**NOTE:**

- All typical values are measured at  $T_{amb} = 25^\circ\text{C}$ .
- At supply voltage approaching 1.2V, the analog switch ON-resistance becomes extremely non-linear. Therefore it is recommended that these devices be used to transmit digital signals only, when using these supply voltages.

Quad bilateral switches

74LV4316

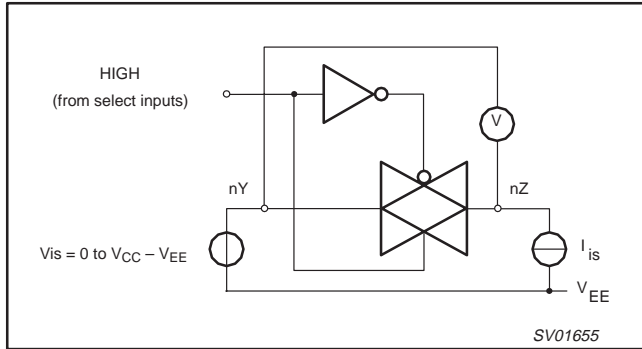

Figure 1. Test circuit for measuring ON-resistance ( $R_{ON}$ ).

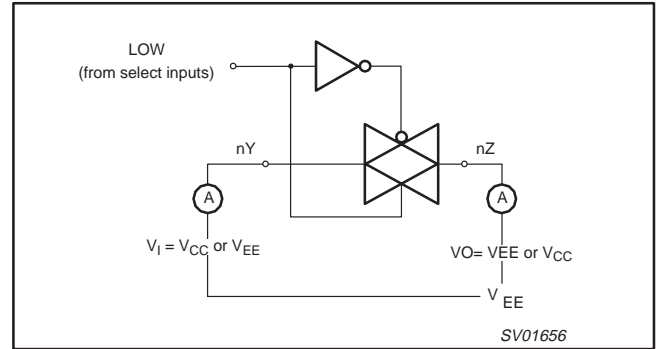

Figure 2. Test circuit for measuring OFF-state current.

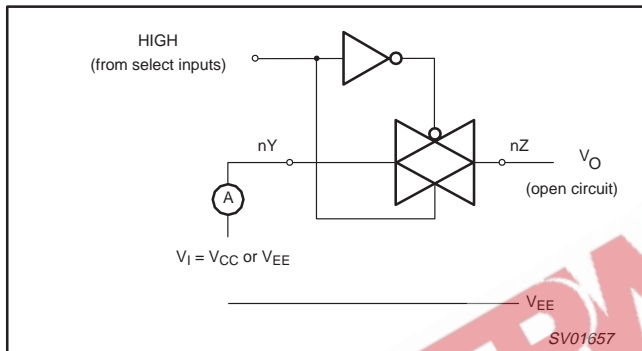

Figure 3. Test circuit for measuring ON-state current.

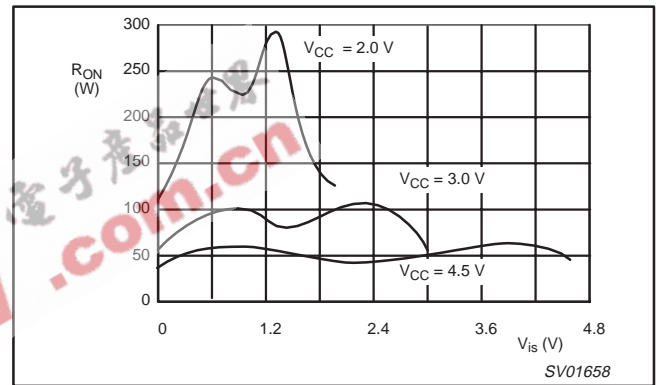

Figure 4. Typical ON-resistance ( $R_{ON}$ ) as a function of input voltage ( $V_{is}$ ) for  $V_{is} = 0 \text{ to } V_{CC} - V_{EE}$ .

## Quad bilateral switches

74LV4316

## AC CHARACTERISTICS

GND = 0 V;  $t_r = t_f \leq 2.5\text{ns}$ ;  $C_L = 50\text{pF}$ 

SYMBOL	PARAMETER	LIMITS					UNIT	CONDITION	
		-40 to +85 °C			-40 to +125 °C			V <sub>CC</sub> (V)	OTHER
		MIN	TYP <sup>1</sup>	MAX	MIN	MAX			
t <sub>PHL</sub> /t <sub>PLH</sub>	Propagation delay V <sub>is</sub> to V <sub>os</sub>		30				ns	1.2	R <sub>L</sub> = ∞; C <sub>L</sub> = 50 pF Figure 12
			10	19		24		2.0	
			8	14		18		2.7	
			6*	11		14		3.0 to 3.6	
			5	9		12		4.5	
			4	7		9		6.0	
t <sub>PZH</sub> /t <sub>PZL</sub>	Turn-on time E to V <sub>os</sub>		110				ns	1.2	R <sub>L</sub> = 1 kΩ; C <sub>L</sub> = 50 pF Figures 13 and 14
			37	70		85		2.0	
			28	51		63		2.7	
			21 <sup>2</sup>	41		50		3.0 to 3.6	
			19	35		43		4.5	
			15	27		33		6.0	
t <sub>PZH</sub> /t <sub>PZL</sub>	Turn-on time nS to V <sub>os</sub>		95				ns	1.2	R <sub>L</sub> = 1 kΩ; C <sub>L</sub> = 50 pF Figures 13 and 14
			32	61		75		2.0	
			24	45		55		2.7	
			18 <sup>2</sup>	36		44		3.0 to 3.6	
			16	31		37		4.5	
			12	23		29		6.0	
t <sub>PHZ</sub> /t <sub>PLZ</sub>	Turn-off time E to V <sub>os</sub>		105				ns	1.2	R <sub>L</sub> = 1 kΩ; C <sub>L</sub> = 50 pF Figures 13 and 14
			37	68		80		2.0	
			28	51		59		2.7	
			22 <sup>2</sup>	41		48		3.0 to 3.6	
			20	35		41		4.5	
			16	28		32		6.0	
t <sub>PHZ</sub> /t <sub>PLZ</sub>	Turn-off time nS to V <sub>os</sub>		90				ns	1.2	R <sub>L</sub> = 1 kΩ; C <sub>L</sub> = 50 pF Figures 13 and 14
			32	59		70		2.0	
			24	44		52		2.7	
			19 <sup>2</sup>	36		42		3.0 to 3.6	
			17	31		36		4.5	
			14	24		28		6.0	

## NOTES:

1. All typical values are measured at T<sub>amb</sub> = 25°C.
2. All typical values are measured at V<sub>CC</sub> = 3.3V

# Quad bilateral switches

# 74LV4316

## ADDITIONAL AC CHARACTERISTICS

GND = 0 V;  $t_r = t_f \leq 2.5\text{ns}$ ;  $C_L = 50\text{pF}$

SYMBOL	PARAMETER	TYP	UNIT	V <sub>CC</sub> (V)	V <sub>IS(P-P)</sub> (V)	CONDITIONS
	Sine-wave distortion f = 1 kHz	0.80	%	3.0	2.75	R <sub>L</sub> = 10 kΩ; C <sub>L</sub> = 50 pF Figure 10
		0.40		6.0	5.50	
	Sine-wave distortion f = 10 kHz	2.40	%	3.0	2.75	R <sub>L</sub> = 10 kΩ; C <sub>L</sub> = 50 pF Figure 10
		1.20		6.0	5.50	
	Switch "OFF" signal feed through	-50	dB	3.0	Note 1	R <sub>L</sub> = 600 kΩ; C <sub>L</sub> = 50 pF; f=1 MHz Figures 5 and 11
		-50		6.0		
	Crosstalk between any two switches	-60	dB	3.0	Note 1	R <sub>L</sub> = 600 kΩ; C <sub>L</sub> = 50 pF; f=1 MHz Figure 7
		-60		6.0		
V <sub>(p-p)</sub>	Crosstalk voltage between enable or address input to any switch (peak-to-peak value)	110	mV	3.0		R <sub>L</sub> = 600 kΩ; C <sub>L</sub> = 50 pF; f=1 MHz (nS or E, square wave between V <sub>CC</sub> and GND, T <sub>r</sub> = t <sub>f</sub> = 6 ns) Figure 8
		220		6.0		
f <sub>max</sub>	Minimum frequency response (-3 dB)	180	mHz	3.0	Note 2	R <sub>L</sub> = 50 kΩ; C <sub>L</sub> = 50 pF Figures 6 and 9
		200		6.0		
C <sub>S</sub>	Maximum switch capacitance	5	pF			

**GENERAL NOTES:**

V<sub>is</sub> is the input voltage at nY or nZ terminal, whichever is assigned as an input.  
V<sub>os</sub> is the output voltage at nY or nZ terminal, whichever is assigned as an output.

**NOTES:**

1. Adjust input voltage V<sub>is</sub> is 0 dBm level (0 dBm = 1 mW into 600 Ω).
2. Adjust input voltage V<sub>is</sub> is 0 dBm level at V<sub>os</sub> for 1 MHz (0 dBm = 1 mW into 50 Ω).

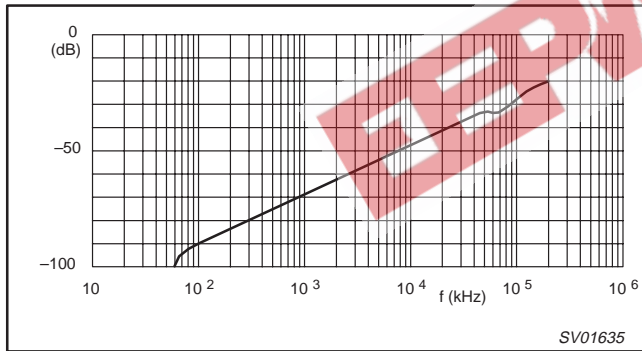

Figure 5. Typical switch "OFF" signal feed-through as a function of frequency.

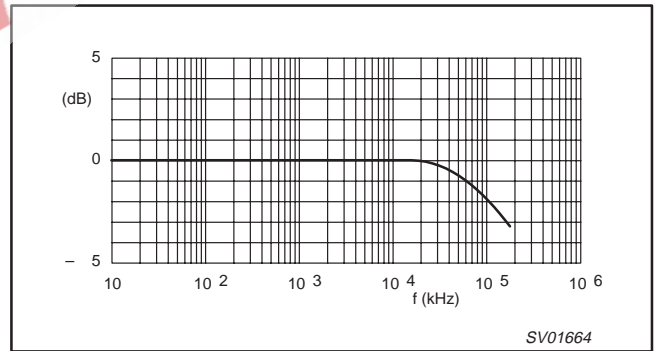

Figure 6. Typical frequency response.

**NOTES TO FIGURES 5 AND 6:**

Test conditions: V<sub>CC</sub> = 3.0 V; GND = 0 V; R<sub>L</sub> = 50 Ω; R<sub>SOURCE</sub> = 1kΩ.

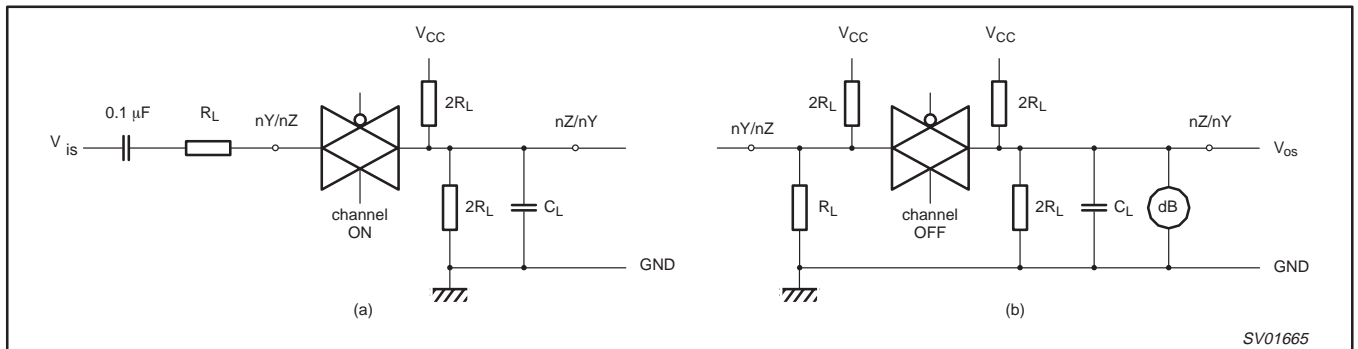
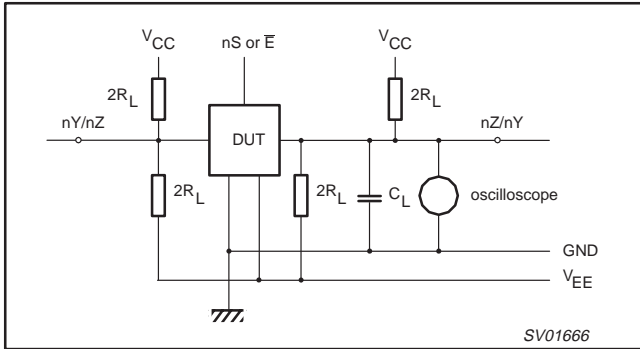

Figure 7. Test circuit for measuring crosstalk between any two switches. (a) channel ON condition; (b) channel OFF condition.



Quad bilateral switches

74LV4316



**Figure 8. Test circuit for measuring crosstalk between control and any switch.**

**NOTE TO FIGURE 8:**

The crosstalk is defined as follows (oscilloscope output):

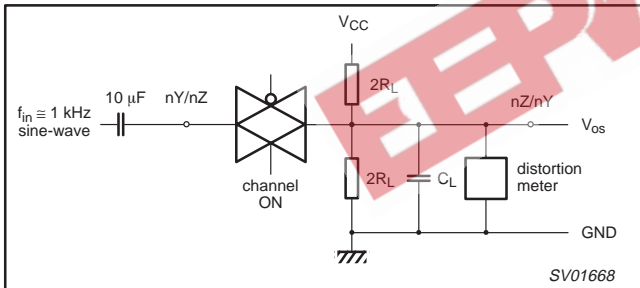
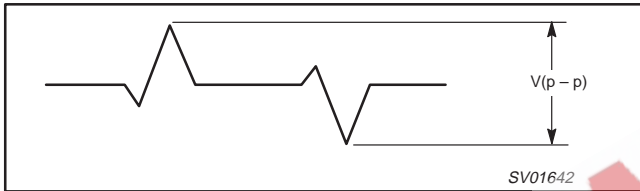

**Figure 10. Test circuit for measuring sine-wave distortion.**

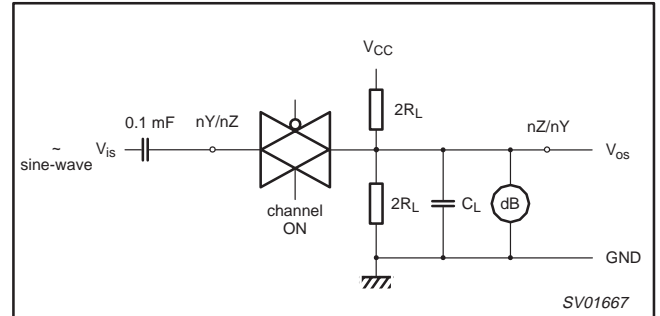

**Figure 9. Test circuit for measuring minimum frequency response.**

**NOTE TO FIGURE 9:**

Adjust input voltage to obtain 0 dBm at  $V_{OS}$  when  $F_{in} = 1$  MHz. After set-up frequency of  $f_{in}$  is increased to obtain a reading of  $-3$  dB at  $V_{OS}$ .

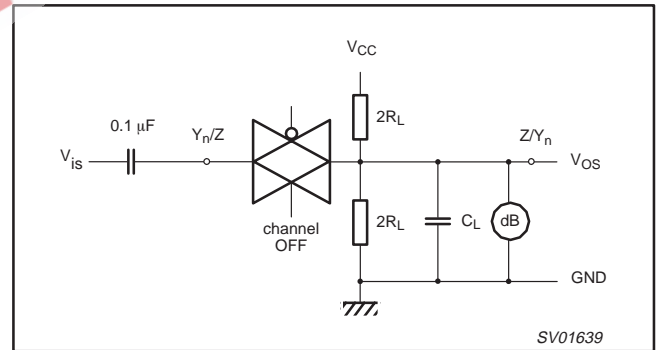

**Figure 11. Test circuit for measuring switch "OFF" signal feed-through.**

Quad bilateral switches

74LV4316

WAVEFORMS

$V_M = 1.5\text{ V}$  at  $2.7\text{ V} \leq V_{CC} \leq 3.6\text{ V}$   
 $V_M = 0.5 \times V_{CC}$  at  $2.7\text{ V} > V_{CC} > 3.6\text{ V}$   
 $V_{OL}$  and  $V_{OH}$  are the typical output voltage drop that occur with the output load  
 $V_X = V_{OL} + 0.3\text{ V}$  at  $2.7\text{ V} \leq V_{CC} \leq 3.6\text{ V}$   
 $V_X = V_{OL} + 0.1 \times V_{CC}$  at  $2.7\text{ V} > V_{CC} > 3.6\text{ V}$   
 $V_Y = V_{OH} - 0.3\text{ V}$  at  $2.7\text{ V} \leq V_{CC} \leq 3.6\text{ V}$   
 $V_Y = V_{OH} - 0.1 \times V_{CC}$  at  $2.7\text{ V} > V_{CC} > 3.6\text{ V}$

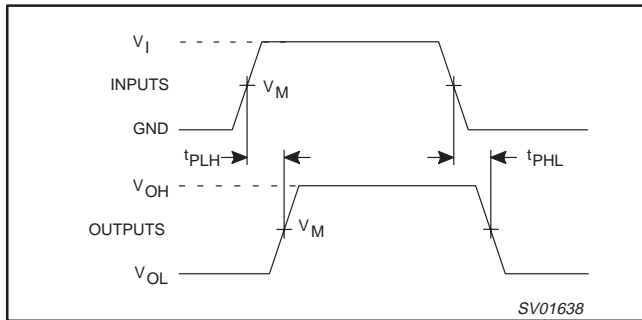

Figure 12. Input ( $V_{is}$ ) to output ( $V_{os}$ ) propagation delays.

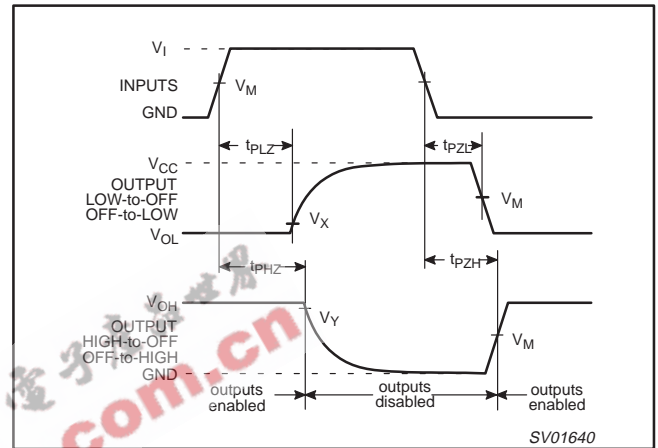

Figure 13. Turn-on and turn-off times for the inputs ( $nS, E$ ) to the output ( $V_{os}$ ).

TEST CIRCUIT

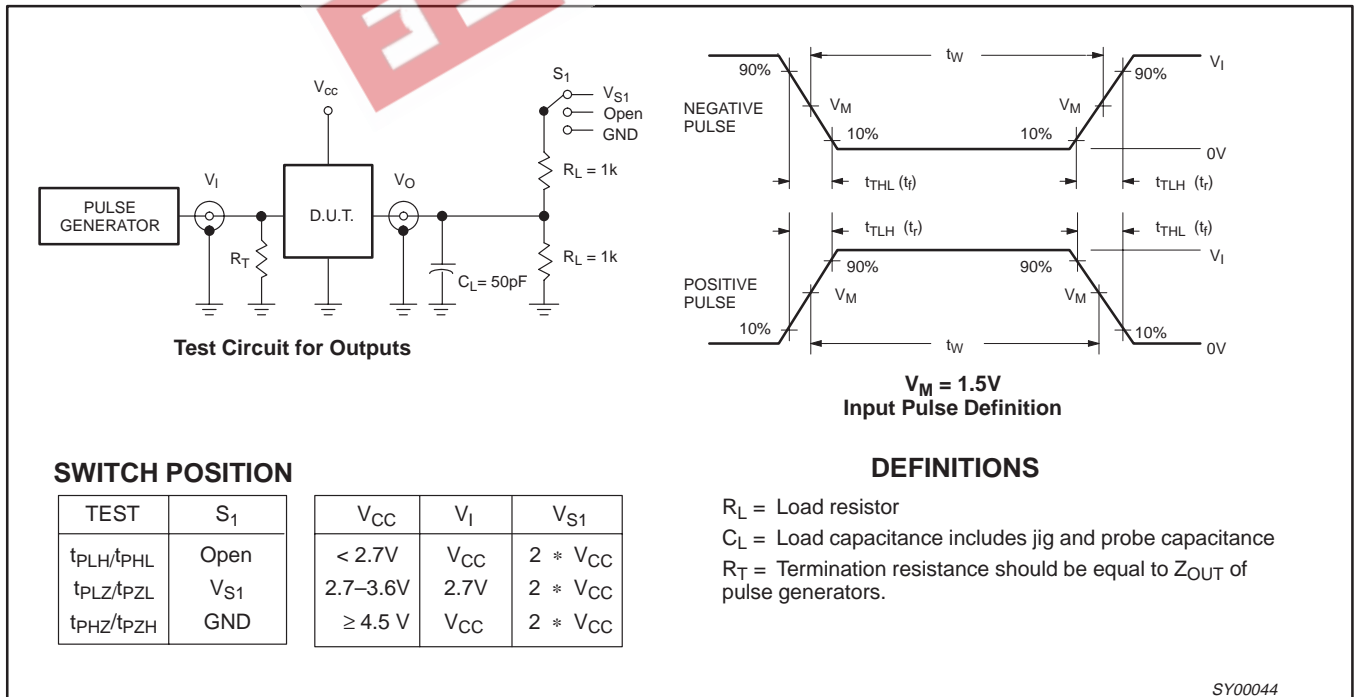

Figure 14. Load circuitry for switching times.

Quad bilateral latches

74LV4316

DIP16: plastic dual in-line package; 16 leads (300 mil)

SOT38-4

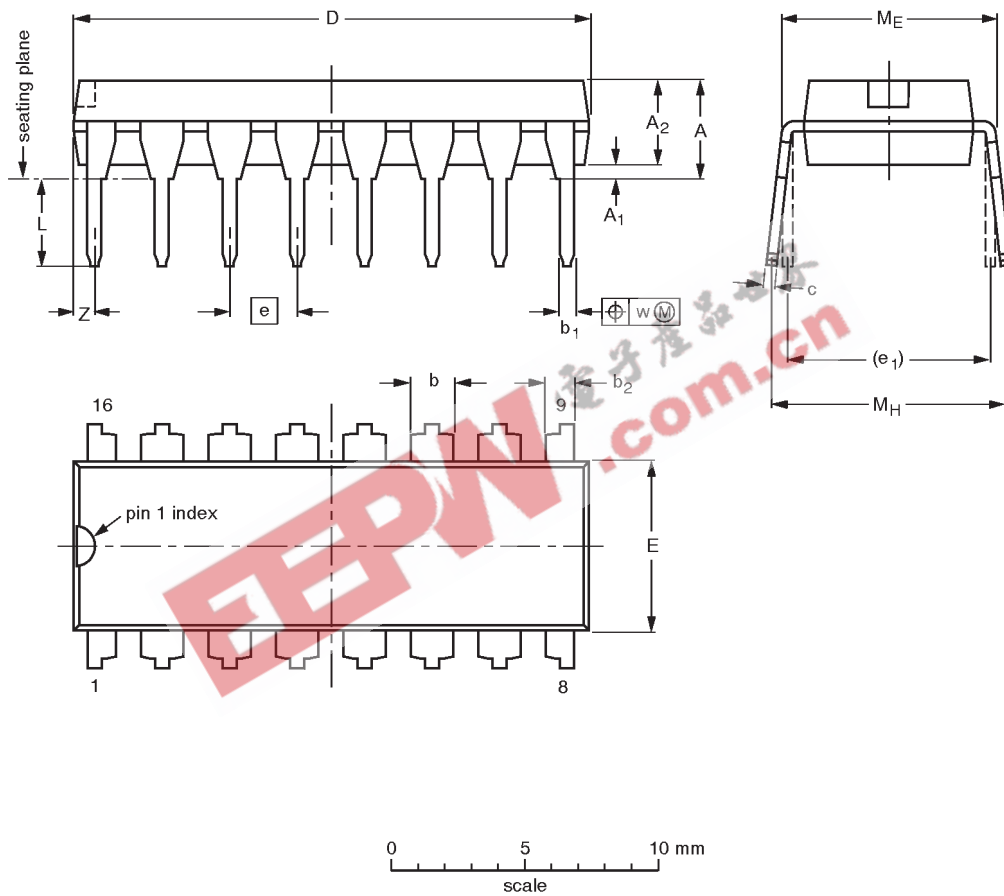

DIMENSIONS (inch dimensions are derived from the original mm dimensions)

UNIT	A max.	A <sub>1</sub> min.	A <sub>2</sub> max.	b	b <sub>1</sub>	b <sub>2</sub>	c	D <sup>(1)</sup>	E <sup>(1)</sup>	e	e <sub>1</sub>	L	M <sub>E</sub>	M <sub>H</sub>	w	z <sup>(1)</sup> max.
mm	4.2	0.51	3.2	1.73 1.30	0.53 0.38	1.25 0.85	0.36 0.23	19.50 18.55	6.48 6.20	2.54	7.62	3.60 3.05	8.25 7.80	10.0 8.3	0.254	0.76
inches	0.17	0.020	0.13	0.068 0.051	0.021 0.015	0.049 0.033	0.014 0.009	0.77 0.73	0.26 0.24	0.10	0.30	0.14 0.12	0.32 0.31	0.39 0.33	0.01	0.030

Note

1. Plastic or metal protrusions of 0.25 mm maximum per side are not included.

OUTLINE VERSION	REFERENCES				EUROPEAN PROJECTION	ISSUE DATE
	IEC	JEDEC	EIAJ			
SOT38-4						92-11-17 95-01-14

Quad bilateral latches

74LV4316

SO16: plastic small outline package; 16 leads; body width 3.9 mm

SOT109-1

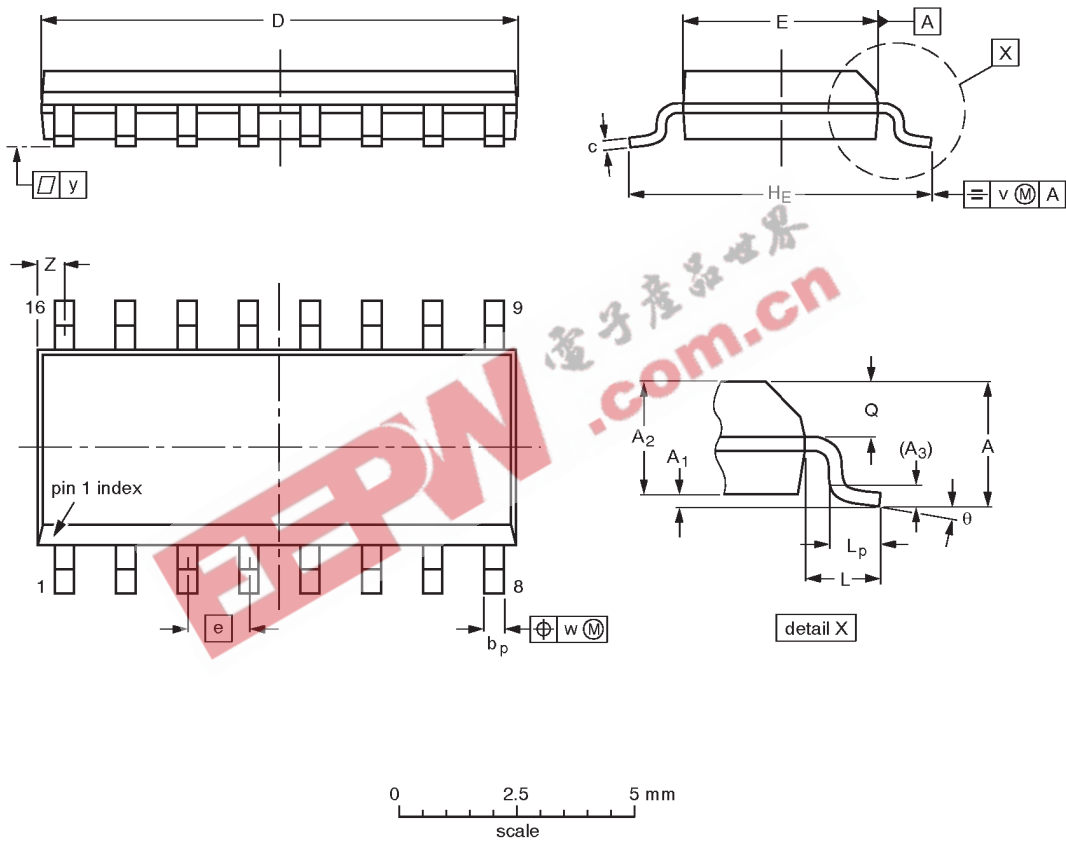

DIMENSIONS (inch dimensions are derived from the original mm dimensions)

UNIT	A max.	A <sub>1</sub>	A <sub>2</sub>	A <sub>3</sub>	b <sub>p</sub>	c	D <sup>(1)</sup>	E <sup>(1)</sup>	e	H <sub>E</sub>	L	L <sub>p</sub>	Q	v	w	y	Z <sup>(1)</sup>	θ
mm	1.75	0.25 0.10	1.45 1.25	0.25	0.49 0.36	0.25 0.19	10.0 9.8	4.0 3.8	1.27	6.2 5.8	1.05	1.0 0.4	0.7 0.6	0.25	0.25	0.1	0.7 0.3	8° 0°
inches	0.069	0.0098 0.0039	0.057 0.049	0.01	0.019 0.014	0.0098 0.0075	0.39 0.38	0.16 0.15	0.050	0.24 0.23	0.041	0.039 0.016	0.028 0.020	0.01	0.01	0.004	0.028 0.012	

Note

1. Plastic or metal protrusions of 0.15 mm maximum per side are not included.

OUTLINE VERSION	REFERENCES				EUROPEAN PROJECTION	ISSUE DATE
	IEC	JEDEC	EIAJ			
SOT109-1	076E07S	MS-012AC				91-08-13 95-01-23

Quad bilateral latches

74LV4316

SSOP16: plastic shrink small outline package; 16 leads; body width 5.3 mm

SOT338-1

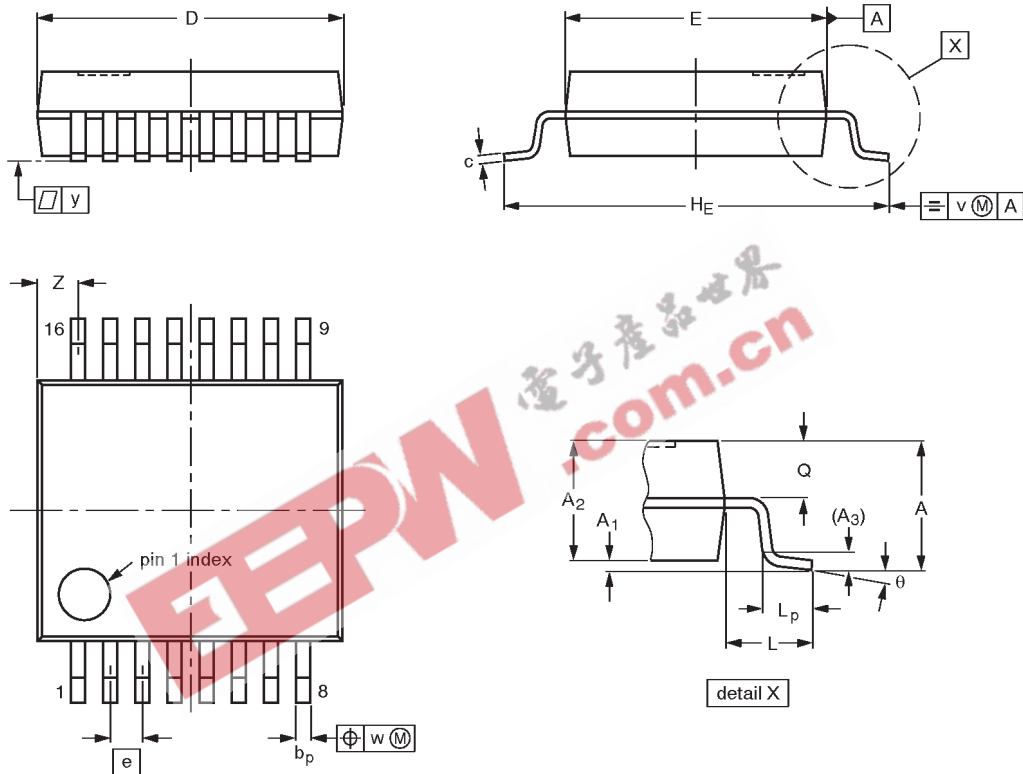

DIMENSIONS (mm are the original dimensions)

UNIT	A max.	A <sub>1</sub>	A <sub>2</sub>	A <sub>3</sub>	b <sub>p</sub>	c	D <sup>(1)</sup>	E <sup>(1)</sup>	e	H <sub>E</sub>	L	L <sub>p</sub>	Q	v	w	y	z <sup>(1)</sup>	θ
mm	2.0	0.21 0.05	1.80 1.65	0.25	0.38 0.25	0.20 0.09	6.4 6.0	5.4 5.2	0.65	7.9 7.6	1.25	1.03 0.63	0.9 0.7	0.2	0.13	0.1	1.00 0.55	8° 0°

Note

1. Plastic or metal protrusions of 0.25 mm maximum per side are not included.

OUTLINE VERSION	REFERENCES				EUROPEAN PROJECTION	ISSUE DATE
	IEC	JEDEC	EIAJ			
SOT338-1		MO-150AC				94-01-14 95-02-04

Quad bilateral latches

74LV4316

TSSOP16: plastic thin shrink small outline package; 16 leads; body width 4.4 mm

SOT403-1

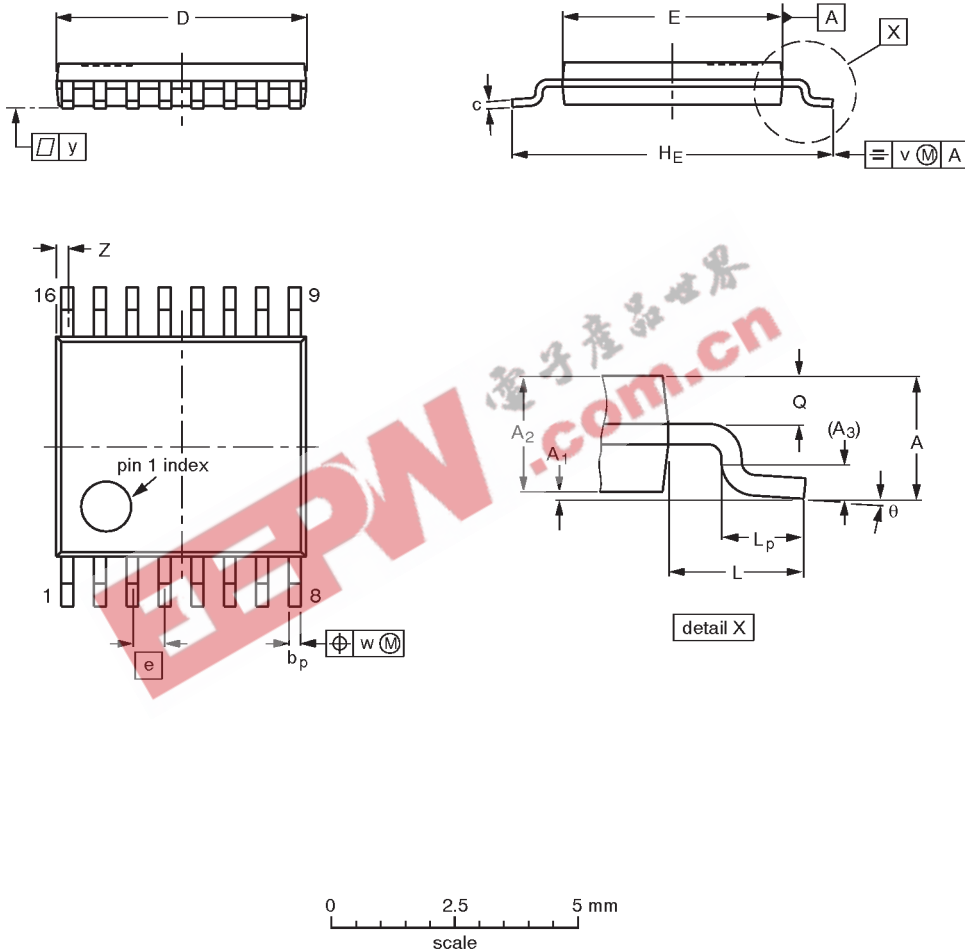

**DIMENSIONS (mm are the original dimensions)**

UNIT	A max.	A <sub>1</sub>	A <sub>2</sub>	A <sub>3</sub>	b <sub>p</sub>	c	D <sup>(1)</sup>	E <sup>(2)</sup>	e	H <sub>E</sub>	L	L <sub>p</sub>	Q	v	w	y	Z <sup>(1)</sup>	θ
mm	1.10	0.15 0.05	0.95 0.80	0.25	0.30 0.19	0.2 0.1	5.1 4.9	4.5 4.3	0.65	6.6 6.2	1.0	0.75 0.50	0.4 0.3	0.2	0.13	0.1	0.40 0.06	8° 0°

**Notes**

1. Plastic or metal protrusions of 0.15 mm maximum per side are not included.
2. Plastic interlead protrusions of 0.25 mm maximum per side are not included.

OUTLINE VERSION	REFERENCES				EUROPEAN PROJECTION	ISSUE DATE
	IEC	JEDEC	EIAJ			
SOT403-1		MO-153				94-07-12 95-04-04

---

Quad bilateral latches

74LV4316

---

NOTES



## Quad bilateral switches

74LV4316

## DEFINITIONS

Data Sheet Identification	Product Status	Definition
<i>Objective Specification</i>	Formative or in Design	This data sheet contains the design target or goal specifications for product development. Specifications may change in any manner without notice.
<i>Preliminary Specification</i>	Preproduction Product	This data sheet contains preliminary data, and supplementary data will be published at a later date. Philips Semiconductors reserves the right to make changes at any time without notice in order to improve design and supply the best possible product.
<i>Product Specification</i>	Full Production	This data sheet contains Final Specifications. Philips Semiconductors reserves the right to make changes at any time without notice, in order to improve design and supply the best possible product.

Philips Semiconductors and Philips Electronics North America Corporation reserve the right to make changes, without notice, in the products, including circuits, standard cells, and/or software, described or contained herein in order to improve design and/or performance. Philips Semiconductors assumes no responsibility or liability for the use of any of these products, conveys no license or title under any patent, copyright, or mask work right to these products, and makes no representations or warranties that these products are free from patent, copyright, or mask work right infringement, unless otherwise specified. Applications that are described herein for any of these products are for illustrative purposes only. Philips Semiconductors makes no representation or warranty that such applications will be suitable for the specified use without further testing or modification.

## LIFE SUPPORT APPLICATIONS

Philips Semiconductors and Philips Electronics North America Corporation Products are not designed for use in life support appliances, devices, or systems where malfunction of a Philips Semiconductors and Philips Electronics North America Corporation Product can reasonably be expected to result in a personal injury. Philips Semiconductors and Philips Electronics North America Corporation customers using or selling Philips Semiconductors and Philips Electronics North America Corporation Products for use in such applications do so at their own risk and agree to fully indemnify Philips Semiconductors and Philips Electronics North America Corporation for any damages resulting from such improper use or sale.

**Philips Semiconductors**  
**811 East Arques Avenue**  
**P.O. Box 3409**  
**Sunnyvale, California 94088-3409**  
**Telephone 800-234-7381**

Philips Semiconductors and Philips Electronics North America Corporation register eligible circuits under the Semiconductor Chip Protection Act.  
 © Copyright Philips Electronics North America Corporation 1998  
 All rights reserved. Printed in U.S.A.

print code

Date of release: 05-96

Document order number:

9397-750-04663

*Let's make things better.*