

## 54F/74F193 Up/Down Binary Counter with Separate Up/Down Clocks

### General Description

The 'F193 is an up/down modulo-16 binary counter. Separate Count Up and Count Down Clocks are used, and in either counting mode the circuits operate synchronously. The outputs change state synchronously with the LOW-to-HIGH transitions on the clock inputs. Separate Terminal Count Up and Terminal Count Down outputs are provided that are used as the clocks for subsequent stages without extra logic, thus simplifying multi-stage counter designs.

Individual preset inputs allow the circuit to be used as a programmable counter. Both the Parallel Load (PL) and the Master Reset (MR) inputs asynchronously override the clocks.

### Features

- Guaranteed 4000V minimum ESD protection

| Commercial        | Military          | Package Number | Package Description                               |
|-------------------|-------------------|----------------|---|
| 74F193PC          |                   | N16E           | 16-Lead (0.300" Wide) Molded Dual-In-Line         |
|                   | 54F193DM (Note 2) | J16A           | 16-Lead Ceramic Dual-In-Line                      |
| 74F193SC (Note 1) |                   | M16A           | 16-Lead (0.150" Wide) Molded Small Outline, JEDEC |
| 74F193SJ (Note 1) |                   | M16D           | 16-Lead (0.300" Wide) Molded Small Outline, EIAJ  |
|                   | 54F193FM (Note 2) | W16A           | 16-Lead Cerpack                                   |
|                   | 54F193LM (Note 2) | E20A           | 20-Lead Ceramic Leadless Chip Carrier, Type C     |

**Note 1:** Devices also available in 13" reel. Use suffix = SCX and SJX.

**Note 2:** Military grade device with environmental and burn-in processing. Use suffix = DMQB, FMQB and LMQB.

### Logic Symbols

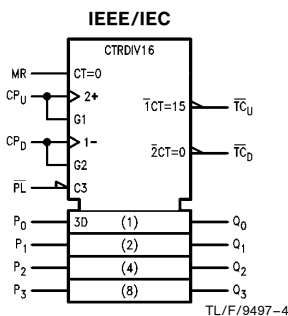
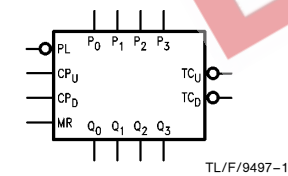

### Connection Diagrams

Pin Assignment for DIP, SOIC and Flatpak

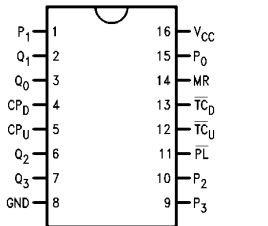

Pin Assignment for LCC

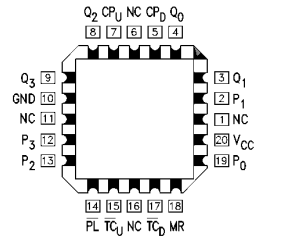

TRI-STATE® is a registered trademark of National Semiconductor Corporation.

## Unit Loading/Fan Out

| Pin Names                      | Description                                      | 54F/74F          |   |
|--------------------------------|--|------------------|---|
|                                |  | U.L.<br>HIGH/LOW | Input $I_{IH}/I_{IL}$<br>Output $I_{OH}/I_{OL}$ |
| CP <sub>U</sub>                | Count Up Clock Input (Active Rising Edge)        | 1.0/3.0          | 20 $\mu$ A/ -1.8 mA                             |
| CP <sub>D</sub>                | Count Down Clock Input (Active Rising Edge)      | 1.0/3.0          | 20 $\mu$ A/ -1.8 mA                             |
| MR                             | Asynchronous Master Reset Input (Active HIGH)    | 1.0/1.0          | 20 $\mu$ A/ -0.6 mA                             |
| $\overline{PL}$                | Asynchronous Parallel Load Input (Active LOW)    | 1.0/1.0          | 20 $\mu$ A/ -0.6 mA                             |
| P <sub>0</sub> -P <sub>3</sub> | Parallel Data Inputs                             | 1.0/1.0          | 20 $\mu$ A/ -0.6 mA                             |
| Q <sub>0</sub> -Q <sub>3</sub> | Flip-Flop Outputs                                | 50/33.3          | -1 mA/20 mA                                     |
| $\overline{TC}_D$              | Terminal Count Down (Borrow) Output (Active LOW) | 50/33.3          | -1 mA/20 mA                                     |
| $\overline{TC}_U$              | Terminal Count Up (Carry) Output (Active LOW)    | 50/33.3          | -1 mA/20 mA                                     |

## Functional Description

The 'F193 is a 4-bit binary synchronous up/down (reversible) counter. It contains four edge-triggered flip-flops, with internal gating and steering logic to provide master reset, individual preset, count up and count down operations.

A LOW-to-HIGH transition on the CP input to each flip-flop causes the output to change state. Synchronous switching, as opposed to ripple counting, is achieved by driving the steering gates of all stages from a common Count Up line and a common Count Down line, thereby causing all state changes to be initiated simultaneously. A LOW-to-HIGH transition on the Count Up input will advance the count by one; a similar transition on the Count Down input will decrease the count by one. While counting with one clock input, the other should be held HIGH, as indicated in the Function Table.

The Terminal Count Up ( $\overline{TC}_U$ ) and Terminal Count Down ( $\overline{TC}_D$ ) outputs are normally HIGH. When the circuit has reached the maximum count state 15, the next HIGH-to-LOW transition of the Count Up Clock will cause  $\overline{TC}_U$  to go LOW.  $\overline{TC}_U$  will stay LOW until CP<sub>U</sub> goes HIGH again, thus effectively repeating the Count Up Clock, but delayed by two gate delays. Similarly, the  $\overline{TC}_D$  output will go LOW when the circuit is in the zero state and the Count Down Clock goes LOW. Since the TC outputs repeat the clock waveforms, they can be used as the clock input signals to the next higher order circuit in a multistage counter.

$$\overline{TC}_U = Q_0 \cdot Q_1 \cdot Q_2 \cdot Q_3 \cdot \overline{CP}_U$$

$$\overline{TC}_D = \overline{Q}_0 \cdot \overline{Q}_1 \cdot \overline{Q}_2 \cdot \overline{Q}_3 \cdot \overline{CP}_D$$

The 'F193 has an asynchronous parallel load capability permitting the counter to be preset. When the Parallel Load ( $\overline{PL}$ ) and the Master Reset (MR) inputs are LOW, information present on the Parallel Data input (P<sub>0</sub>-P<sub>3</sub>) is loaded into the counter and appears on the outputs regardless of the conditions of the clock inputs. A HIGH signal on the Master Reset input will disable the preset gates, override both clock inputs, and latch each Q output in the LOW state.

If one of the clock inputs is LOW during and after a reset or load operation, the next LOW-to-HIGH transition of that clock will be interpreted as a legitimate signal and will be counted.

Function Table

| MR | $\overline{PL}$ | CP <sub>U</sub> | CP <sub>D</sub> | Mode           |
|----|-----------------|-----------------|-----------------|----------------|
| H  | X               | X               | X               | Reset (Asyn.)  |
| L  | L               | X               | X               | Preset (Asyn.) |
| L  | H               | H               | H               | No Change      |
| L  | H               | $\nearrow$      | H               | Count Up       |
| L  | H               | H               | $\nwarrow$      | Count Down     |

H = HIGH Voltage Level  
L = LOW Voltage Level  
X = Immaterial  
 $\nearrow$  = LOW-to-HIGH Clock Transition

## State Diagram

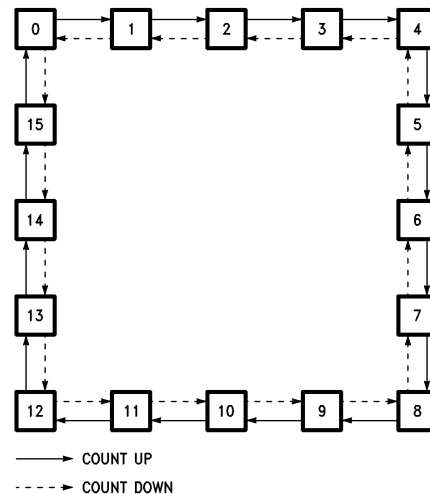

TL/F/9497-5

# Logic Diagram

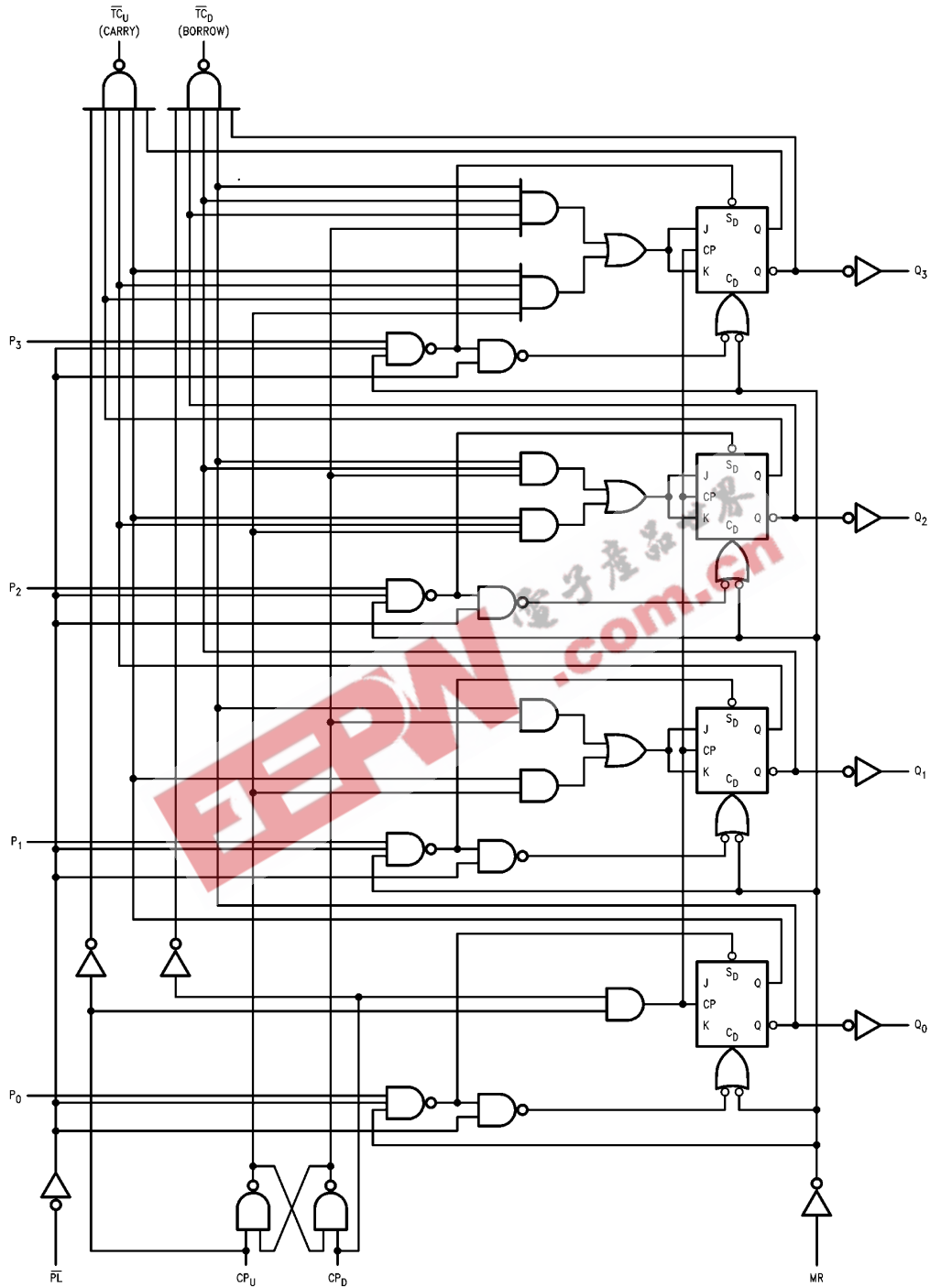

Please note that this diagram is provided only for the understanding of logic operations and should not be used to estimate propagation delays.

TL/F/9497-6

## Absolute Maximum Ratings (Note 1)

If Military/Aerospace specified devices are required, please contact the National Semiconductor Sales Office/Distributors for availability and specifications.

|   |                                      |
|---|--------------------------------------|
| Storage Temperature   | -65°C to +150°C                      |
| Ambient Temperature under Bias                                      | -55°C to +125°C                      |
| Junction Temperature under Bias                                     | -55°C to +175°C                      |
| Plastic   | -55°C to +150°C                      |
| V <sub>CC</sub> Pin Potential to Ground Pin                         | -0.5V to +7.0V                       |
| Input Voltage (Note 2)  | -0.5V to +7.0V                       |
| Input Current (Note 2)  | -30 mA to +5.0 mA                    |
| Voltage Applied to Output in HIGH State (with V <sub>CC</sub> = 0V) |                                      |
| Standard Output   | -0.5V to V <sub>CC</sub>             |
| TRI-STATE® Output   | -0.5V to +5.5V                       |
| Current Applied to Output in LOW State (Max)                        | twice the rated I <sub>OL</sub> (mA) |
| ESD Last Passing Voltage (Min)                                      | 4000V                                |

**Note 1:** Absolute maximum ratings are values beyond which the device may be damaged or have its useful life impaired. Functional operation under these conditions is not implied.

**Note 2:** Either voltage limit or current limit is sufficient to protect inputs.

## Recommended Operating Conditions

|                              |                 |
|------------------------------|-----------------|
| Free Air Ambient Temperature |                 |
| Military                     | -55°C to +125°C |
| Commercial                   | 0°C to +70°C    |
| Supply Voltage               |                 |
| Military                     | +4.5V to +5.5V  |
| Commercial                   | +4.5V to +5.5V  |

## DC Electrical Characteristics

| Symbol           | Parameter                         | 54F/74F  |                   |              | Units | V <sub>CC</sub> | Conditions   |
|------------------|-----------------------------------|--|-------------------|--------------|-------|-----------------|--|
|                  |                                   | Min  | Typ               | Max          |       |                 |  |
| V <sub>IH</sub>  | Input HIGH Voltage                | 2.0  |                   |              | V     |                 | Recognized as a HIGH Signal  |
| V <sub>IL</sub>  | Input LOW Voltage                 |  |                   | 0.8          | V     |                 | Recognized as a LOW Signal   |
| V <sub>CD</sub>  | Input Clamp Diode Voltage         |  |                   | -1.2         | V     | Min             | I <sub>IN</sub> = -18 mA   |
| V <sub>OH</sub>  | Output HIGH Voltage               | 54F 10% V <sub>CC</sub><br>74F 10% V <sub>CC</sub><br>74F 5% V <sub>CC</sub> | 2.5<br>2.5<br>2.7 |              | V     | Min             | I <sub>OH</sub> = -1 mA<br>I <sub>OH</sub> = -1 mA<br>I <sub>OH</sub> = -1 mA  |
| V <sub>OL</sub>  | Output LOW Voltage                | 54F 10% V <sub>CC</sub><br>74F 10% V <sub>CC</sub>                           |                   | 0.5<br>0.5   | V     | Min             | I <sub>OL</sub> = 20 mA<br>I <sub>OL</sub> = 20 mA   |
| I <sub>IH</sub>  | Input HIGH Current                | 54F<br>74F   |                   | 20.0<br>5.0  | μA    | Max             | V <sub>IN</sub> = 2.7V   |
| I <sub>BVI</sub> | Input HIGH Current Breakdown Test | 54F<br>74F   |                   | 100<br>7.0   | μA    | Max             | V <sub>IN</sub> = 7.0V   |
| I <sub>CEX</sub> | Output HIGH Leakage Current       | 54F<br>74F   |                   | 250<br>50    | μA    | Max             | V <sub>OUT</sub> = V <sub>CC</sub>   |
| V <sub>ID</sub>  | Input Leakage Test                | 74F  | 4.75              |              | V     | 0.0             | I <sub>ID</sub> = 1.9 μA<br>All Other Pins Grounded  |
| I <sub>OD</sub>  | Output Leakage Circuit Current    | 74F  |                   | 3.75         | μA    | 0.0             | V <sub>IOD</sub> = 150 mV<br>All Other Pins Grounded   |
| I <sub>IL</sub>  | Input LOW Current                 |  |                   | -0.6<br>-1.8 | mA    | Max             | V <sub>IN</sub> = 0.5V (MR, $\overline{P_L}$ , P <sub>n</sub> )<br>V <sub>IN</sub> = 0.5V (CP <sub>u</sub> , CP <sub>D</sub> ) |
| I <sub>OS</sub>  | Output Short-Circuit Current      |  | -60               | -150         | mA    | Max             | V <sub>OUT</sub> = 0V  |
| I <sub>CC</sub>  | Power Supply Current              |  | 38                | 55           | mA    | Max             |  |

| AC Electrical Characteristics            |  |   |              |  |  |  |  |              |       |
|--|--|---|--------------|--|--|--|--|--------------|-------|
| Symbol                                   | Parameter  | 74F   |              |  | 54F  |  | 74F  |              | Units |
|  |  | T <sub>A</sub> = +25°C<br>V <sub>CC</sub> = +5.0V<br>C <sub>L</sub> = 50 pF |              |  | T <sub>A</sub> , V <sub>CC</sub> = Mil<br>C <sub>L</sub> = 50 pF |  | T <sub>A</sub> , V <sub>CC</sub> = Com<br>C <sub>L</sub> = 50 pF |              |       |
|  |  | Min   | Typ          | Max                                    | Min  | Max                                    | Min  | Max          |       |
| f <sub>max</sub>                         | Maximum Count Frequency  | 100   | 125          |  | 75   |  | 90   |              | MHz   |
| t <sub>PLH</sub><br>t <sub>PHL</sub>     | Propagation Delay<br>CP <sub>U</sub> or CP <sub>D</sub> to<br>$\overline{TC}_U$ or $\overline{TC}_D$ | 4.0<br>3.5  | 7.0<br>6.0   | 9.0<br>8.0                             | 4.0<br>3.5   | 10.5<br>9.5                            | 4.0<br>3.5   | 10.0<br>9.0  | ns    |
| t <sub>PLH</sub><br>t <sub>PHL</sub>     | Propagation Delay<br>CP <sub>U</sub> or CP <sub>D</sub> to Q <sub>n</sub>                            | 4.0<br>5.5  | 6.5<br>9.5   | 8.5<br>12.5                            | 3.5<br>5.5   | 10.0<br>14.0                           | 4.0<br>5.5   | 9.5<br>13.5  | ns    |
| t <sub>PLH</sub><br>t <sub>PHL</sub>     | Propagation Delay<br>P <sub>n</sub> to Q <sub>n</sub>  | 3.0<br>6.0  | 4.5<br>11.0  | 7.0<br>14.5                            | 3.0<br>6.0   | 8.5<br>16.5                            | 3.0<br>6.0   | 8.0<br>15.5  | ns    |
| t <sub>PLH</sub><br>t <sub>PHL</sub>     | Propagation Delay<br>$\overline{PL}$ to Q <sub>n</sub>   | 5.0<br>5.5  | 8.5<br>10.0  | 11.0<br>13.0                           | 5.0<br>5.5   | 13.5<br>15.0                           | 5.0<br>5.5   | 12.0<br>14.0 | ns    |
| t <sub>PHL</sub>                         | Propagation Delay<br>MR to Q <sub>n</sub>  | 5.5   | 11.0         | 14.5                                   | 5.0  | 16.0                                   | 5.5  | 15.5         | ns    |
| t <sub>PLH</sub>                         | Propagation Delay<br>MR to $\overline{TC}_U$   | 6.0   | 10.5         | 13.5                                   | 5.0  | 15.0                                   | 6.0  | 14.5         |       |
| t <sub>PHL</sub>                         | Propagation Delay<br>MR to $\overline{TC}_D$   | 6.0   | 11.5         | 14.5                                   | 6.0  | 16.0                                   | 6.0  | 15.5         |       |
| t <sub>PLH</sub><br>t <sub>PHL</sub>     | Propagation Delay<br>$\overline{PL}$ to $\overline{TC}_U$ or $\overline{TC}_D$                       | 7.0<br>7.0  | 12.0<br>11.5 | 15.5<br>14.5                           | 7.0<br>6.0   | 18.5<br>17.5                           | 7.0<br>7.0   | 16.5<br>15.5 | ns    |
| t <sub>PLH</sub><br>t <sub>PHL</sub>     | Propagation Delay<br>P <sub>n</sub> to $\overline{TC}_U$ or $\overline{TC}_D$                        | 7.0<br>6.5  | 11.5<br>11.0 | 14.5<br>14.0                           | 6.0<br>5.0   | 16.5<br>16.5                           | 7.0<br>6.5   | 15.5<br>15.0 | ns    |
| AC Operating Requirements                |  |   |              |  |  |  |  |              |       |
| Symbol                                   | Parameter  | 74F   |              | 54F                                    |  | 74F                                    |  | Units        |       |
|  |  | T <sub>A</sub> = +25°C<br>V <sub>CC</sub> = +5.0V                           |              | T <sub>A</sub> , V <sub>CC</sub> = Mil |  | T <sub>A</sub> , V <sub>CC</sub> = Com |  |              |       |
|  |  | Min   | Max          | Min                                    | Max  | Min                                    | Max  |              |       |
| t <sub>s</sub> (H)<br>t <sub>s</sub> (L) | Setup Time, HIGH or LOW<br>P <sub>n</sub> to $\overline{PL}$   | 4.5<br>4.5  |              |  | 6.0<br>6.0   |  | 5.0<br>5.0   | ns           |       |
| t <sub>h</sub> (H)<br>t <sub>h</sub> (L) | Hold Time, HIGH or LOW<br>P <sub>n</sub> to $\overline{PL}$  | 2.0<br>2.0  |              |  | 2.0<br>2.0   |  | 2.0<br>2.0   |              |       |
| t <sub>w</sub> (L)                       | $\overline{PL}$ Pulse Width, LOW   | 6.0   |              |  | 7.5  |  | 6.0  | ns           |       |
| t <sub>w</sub> (L)                       | CP <sub>U</sub> or CP <sub>D</sub><br>Pulse Width, LOW   | 5.0   |              |  | 7.0  |  | 5.0  | ns           |       |
| t <sub>w</sub> (L)                       | CP <sub>U</sub> or CP <sub>D</sub><br>Pulse Width, LOW<br>(Change of Direction)                      | 10.0  |              |  | 12.0   |  | 10.0   | ns           |       |
| t <sub>w</sub> (H)                       | MR Pulse Width, HIGH   | 6.0   |              |  | 6.0  |  | 6.0  | ns           |       |
| t <sub>rec</sub>                         | Recovery Time<br>$\overline{PL}$ to CP <sub>U</sub> or CP <sub>D</sub>                               | 6.0   |              |  | 8.0  |  | 6.0  | ns           |       |
| t <sub>rec</sub>                         | Recovery Time<br>MR to CP <sub>U</sub> or CP <sub>D</sub>  | 4.0   |              |  | 4.5  |  | 4.0  | ns           |       |

## Ordering Information

The device number is used to form part of a simplified purchasing code where the package type and temperature range are defined as follows:

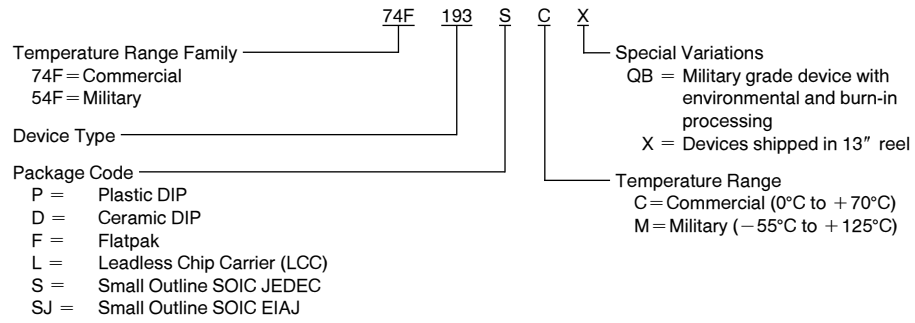

EEPW 电子产品世界  
.com.cn

**Physical Dimensions** inches (millimeters)

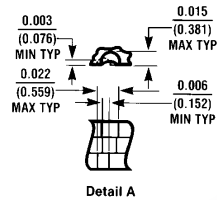
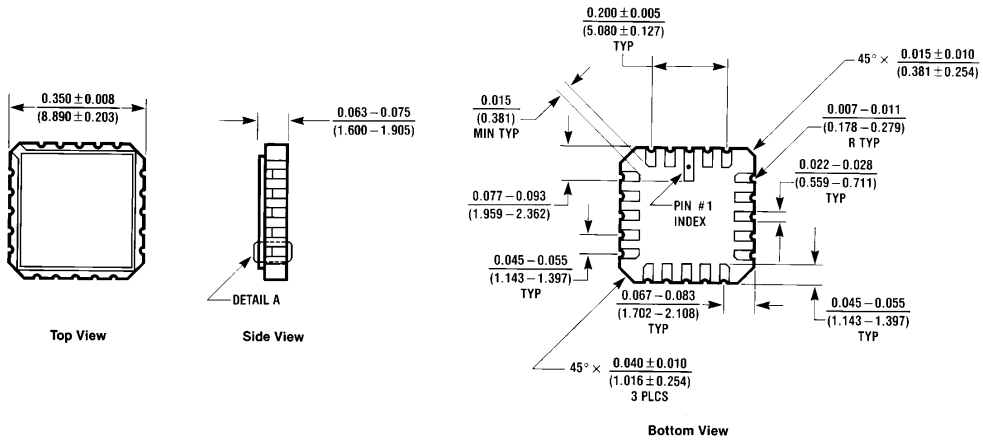

**20-Lead Ceramic Leadless Chip Carrier (L)**  
 NS Package Number E20A

E20A (REV D)

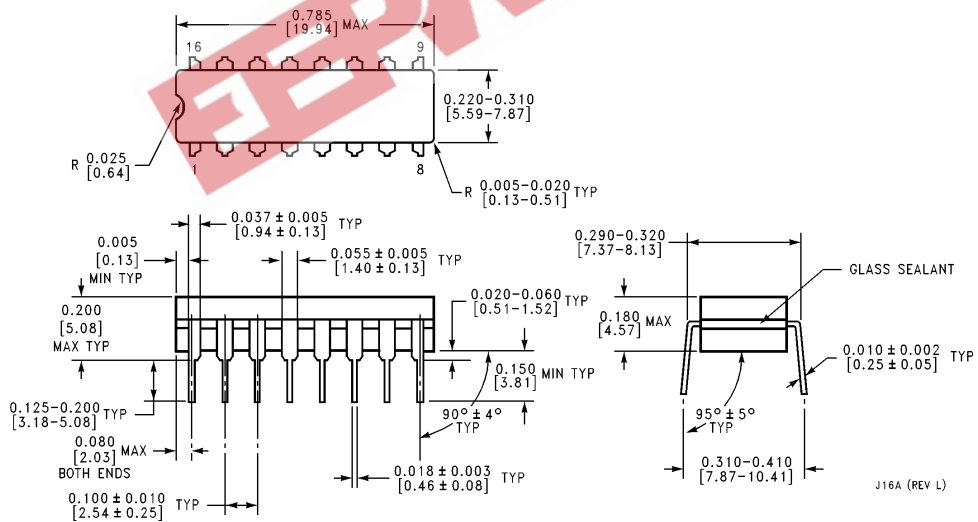

**16-Lead Ceramic Dual-In-Line Package (D)**  
 NS Package Number J16A

J16A (REV L)

**Physical Dimensions** inches (millimeters) (Continued)

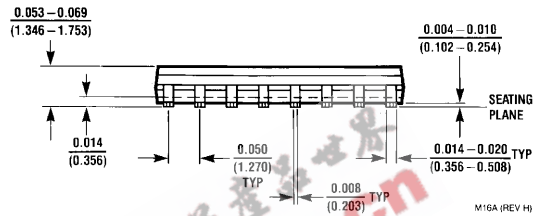
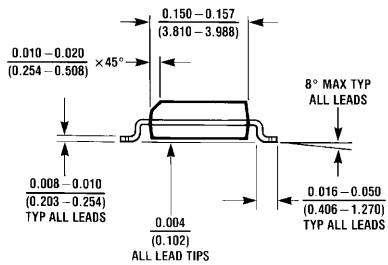
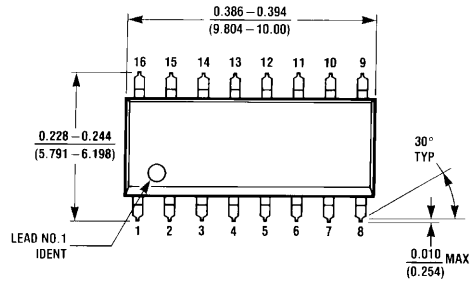

**16-Lead (0.150" Wide) Molded Small Outline Package, JEDEC (S)**  
NS Package Number M16A

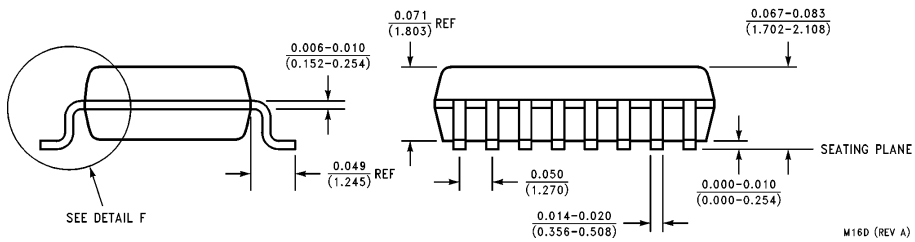
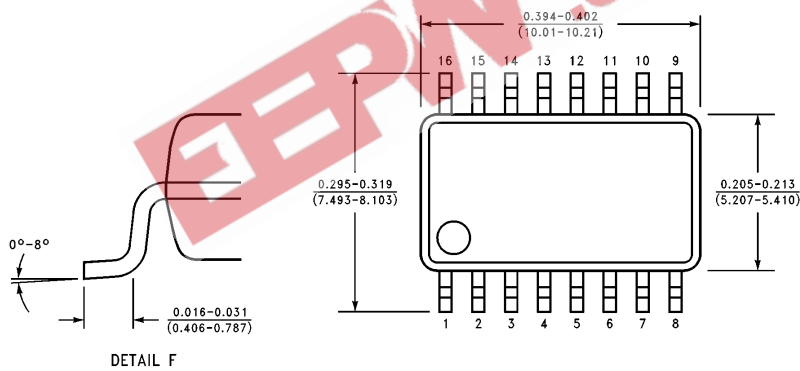

**16-Lead (0.300" Wide) Molded Small Outline Package, EIAJ (SJ)**  
NS Package Number M16D



**Physical Dimensions** inches (millimeters) (Continued)

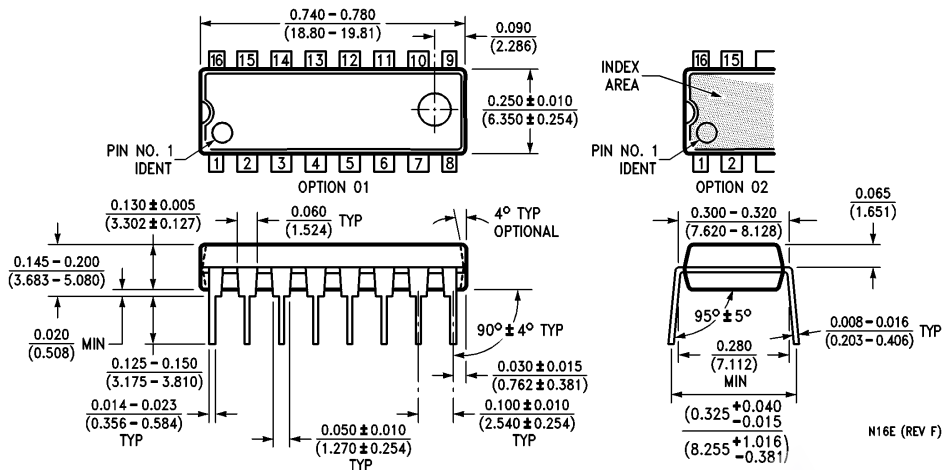

**16-Lead (0.300" Wide) Molded Dual-In-Line Package (P)**  
**NS Package Number N16E**

EEPW.com.cn 电子产品世界

**Physical Dimensions** inches (millimeters) (Continued)

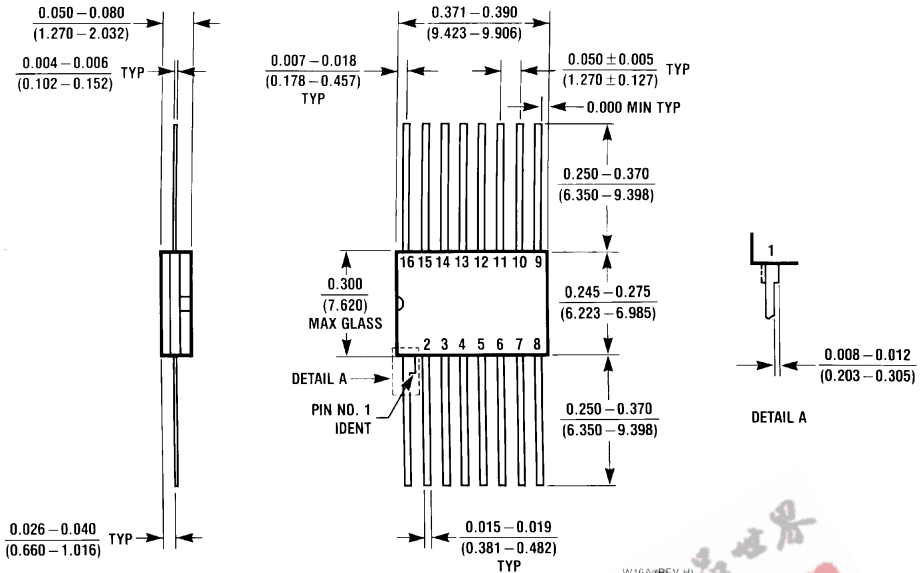

**16-Lead Ceramic Flatpak (F)  
NS Package Number W16A**

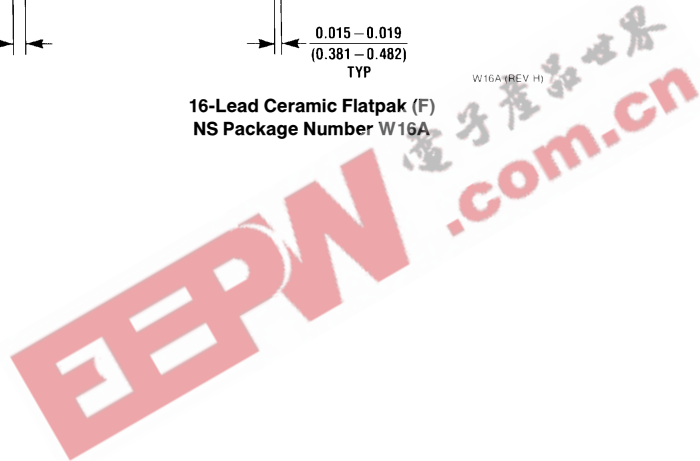

**LIFE SUPPORT POLICY**

NATIONAL'S PRODUCTS ARE NOT AUTHORIZED FOR USE AS CRITICAL COMPONENTS IN LIFE SUPPORT DEVICES OR SYSTEMS WITHOUT THE EXPRESS WRITTEN APPROVAL OF THE PRESIDENT OF NATIONAL SEMICONDUCTOR CORPORATION. As used herein:

1. Life support devices or systems are devices or systems which, (a) are intended for surgical implant into the body, or (b) support or sustain life, and whose failure to perform, when properly used in accordance with instructions for use provided in the labeling, can be reasonably expected to result in a significant injury to the user.
2. A critical component is any component of a life support device or system whose failure to perform can be reasonably expected to cause the failure of the life support device or system, or to affect its safety or effectiveness.

|   |   |   |   |  |   |
|---|---|---|---|--|---|
|  <p><b>National Semiconductor Corporation</b><br/>2900 Semiconductor Drive<br/>P.O. Box 58090<br/>Santa Clara, CA 95052-8090<br/>Tel: (800) 272-9959<br/>TWX: (910) 339-9240</p> | <p><b>National Semiconductor GmbH</b><br/>Livry-Gargan-Str. 10<br/>D-82256 Fürstenfeldbruck<br/>Germany<br/>Tel: (81-41) 35-0<br/>Telex: 527649<br/>Fax: (81-41) 35-1</p> | <p><b>National Semiconductor Japan Ltd.</b><br/>Sumitomo Chemical Engineering Center<br/>Bldg. 7F<br/>1-7-1, Nakase, Mihama-Ku<br/>Chiba-City,<br/>Chiba Prefecture 261<br/>Tel: (043) 299-2300<br/>Fax: (043) 299-2500</p> | <p><b>National Semiconductor Hong Kong Ltd.</b><br/>13th Floor, Straight Block,<br/>Ocean Centre, 5 Canton Rd.<br/>Tsimshatsui, Kowloon<br/>Hong Kong<br/>Tel: (852) 2737-1600<br/>Fax: (852) 2736-9960</p> | <p><b>National Semiconductores Do Brazil Ltda.</b><br/>Rue Deputado Lacorda Franco<br/>120-3A<br/>Sao Paulo-SP<br/>Brazil 05418-000<br/>Tel: (55-11) 212-5066<br/>Telex: 391-1131931 NSBR BR<br/>Fax: (55-11) 212-1181</p> | <p><b>National Semiconductor (Australia) Pty, Ltd.</b><br/>Building 16<br/>Business Park Drive<br/>Monash Business Park<br/>Nottingham, Melbourne<br/>Victoria 3168 Australia<br/>Tel: (3) 558-9889<br/>Fax: (3) 558-9898</p> |
|---|---|---|---|--|---|

National does not assume any responsibility for use of any circuitry described, no circuit patent licenses are implied and National reserves the right at any time without notice to change said circuitry and specifications.