

DATA SHEET

EEPW 电子產品世界
.com.cn

74LVC273

Octal D-type flip-flop with reset;
positive-edge trigger

Product specification
Supersedes data of 1996 Jun 06
IC24 Data Handbook

1998 May 20

Octal D-type flip-flop with reset; positive-edge trigger

74LVC273

FEATURES

- Wide supply voltage range of 1.2V to 3.6V
- Conforms to JEDEC standard 8-1A
- Inputs accept voltages up to 5.5V
- CMOS low power consumption
- Direct interface with TTL levels
- Output drive capability 50Ω transmission lines @ 85°C

DESCRIPTION

The 74LVC273 is a low-voltage Si-gate CMOS device, superior to most advanced CMOS compatible TTL families.

The 74LVC273 has eight edge-triggered, D-type flip-flops with individual D inputs and Q outputs. The common clock (CP) and master reset (MR) inputs load and reset (clear) all flip-flops simultaneously. The state of each D input, one set-up time before the LOW-to-HIGH clock transition, is transferred to the corresponding output (Qn) of the flip-flop.

All outputs will be forced LOW independently of clock or data inputs by a LOW voltage level on the MR input.

The device is useful for applications where the true output only is required and the clock and master reset are common to all storage elements.

QUICK REFERENCE DATA

GND = 0V; $T_{amb} = 25^{\circ}\text{C}$; $t_r = t_f \leq 2.5 \text{ ns}$

SYMBOL	PARAMETER	CONDITIONS	TYPICAL	UNIT
t_{PHL}/t_{PLH}	Propagation delay CP to Qn; MR to Qn	$C_L = 50\text{pF}$ $V_{CC} = 3.3\text{V}$	6.0 6.0	ns
f_{max}	Maximum clock frequency		230	MHz
C_I	Input capacitance		5.0	pF
C_{PD}	Power dissipation capacitance per flip-flop	$V_I = \text{GND to } V_{CC}^1$	22	pF

NOTE:

- 1 C_{PD} is used to determine the dynamic power dissipation (P_D in μW)
 $P_D = C_{PD} \times V_{CC}^2 \times f_i + \sum (C_L \times V_{CC}^2 \times f_o)$ where:
 f_i = input frequency in MHz; C_L = output load capacity in pF;
 f_o = output frequency in MHz; V_{CC} = supply voltage in V;
 $\sum (C_L \times V_{CC}^2 \times f_o)$ = sum of the outputs.

ORDERING INFORMATION

PACKAGES	TEMPERATURE RANGE	OUTSIDE NORTH AMERICA	NORTH AMERICA	DWG NUMBER
20-Pin Plastic SO	-40°C to +85°C	74LVC273 D	74LVC273 D	SOT163-1
20-Pin Plastic SSOP Type II	-40°C to +85°C	74LVC273 DB	74LVC273 DB	SOT339-1
20-Pin Plastic TSSOP Type I	-40°C to +85°C	74LVC273 PW	74LVC273PW DH	SOT360-1

PIN CONFIGURATION

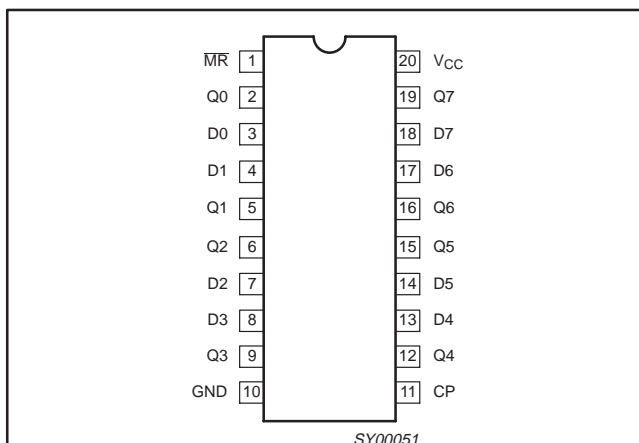

PIN DESCRIPTION

PIN NUMBER	SYMBOL	FUNCTION
1	MR	Master reset input (active LOW)
2, 5, 6, 9, 12, 15, 16, 19	Q0 – Q7	Flip-flop outputs
3, 4, 7, 8, 13, 14, 17, 18	D0 – D7	Data inputs
10	GND	Ground (0V)
11	CP	Clock input (LOW-to-HIGH, edge-triggered)
20	V_{CC}	Positive power supply

Octal D-type flip-flop with reset; positive-edge trigger

74LVC273

LOGIC SYMBOL

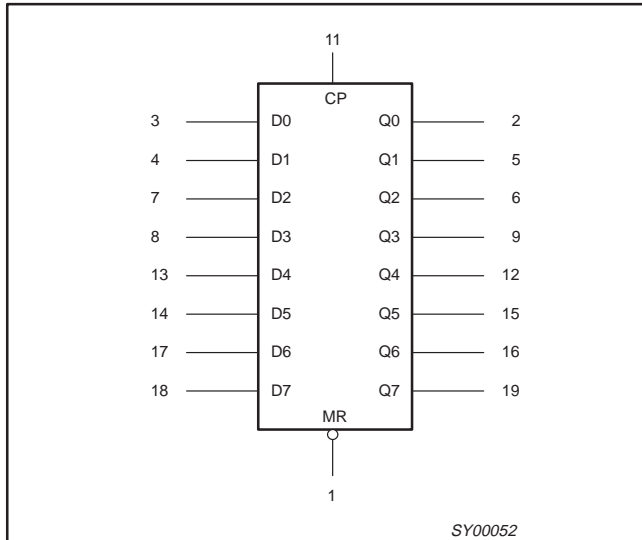

IEEE/IEC LOGIC SYMBOL

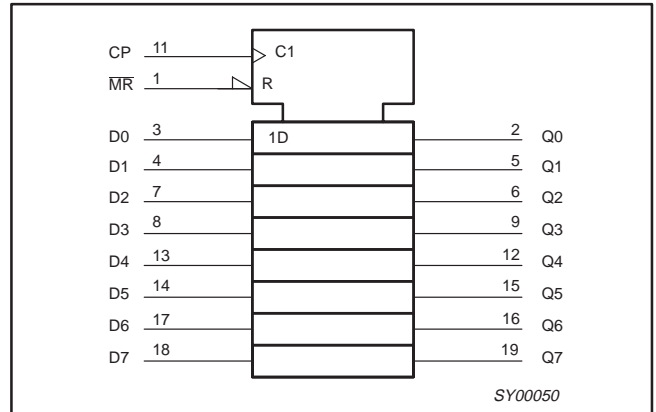

FUNCTION TABLE

OPERATING MODES	INPUTS			OUTPUT Q0 – Q7
	MR	CP	Dn	
Reset (clear)	L	X	X	L
Load '1'	H	↑	h	H
Load '0'	H	↑	l	L

- H = HIGH voltage level
- h = HIGH voltage level one set-up time prior to the HIGH-to-LOW CP transition
- L = LOW voltage level
- l = LOW voltage level one set-up time prior to the HIGH-to-LOW CP transition
- ↑ = LOW-to-HIGH transition
- X = Don't care

RECOMMENDED OPERATING CONDITIONS

SYMBOL	PARAMETER	CONDITIONS	LIMITS		UNIT
			MIN	MAX	
V _{CC}	DC supply voltage (for max. speed performance)		2.7	3.6	V
	DC supply voltage (for low-voltage applications)		1.2	3.6	
V _I	DC Input voltage range		0	5.5	V
V _{I/O}	DC Input voltage range for I/Os		0	V _{CC}	V
V _O	DC output voltage range		0	V _{CC}	V
T _{amb}	Operating free-air temperature range		-40	+85	°C
t _r , t _f	Input rise and fall times	V _{CC} = 1.2 to 2.7V V _{CC} = 2.7 to 3.6V	0	20 10	ns/V

Octal D-type flip-flop with reset; positive-edge trigger

74LVC273

ABSOLUTE MAXIMUM RATINGS¹

In accordance with the Absolute Maximum Rating System (IEC 134)

Voltages are referenced to GND (ground = 0V)

SYMBOL	PARAMETER	CONDITIONS	RATING	UNIT
V_{CC}	DC supply voltage		-0.5 to +6.5	V
I_{IK}	DC input diode current	$V_I < 0$	-50	mA
V_I	DC input voltage	Note 2	-0.5 to +5.5	V
I_{OK}	DC output diode current	$V_O > V_{CC}$ or $V_O < 0$	± 50	mA
V_O	DC output voltage	Note 2	-0.5 to $V_{CC} + 0.5$	V
I_O	DC output source or sink current	$V_O = 0$ to V_{CC}	± 50	mA
I_{GND}, I_{CC}	DC V_{CC} or GND current		± 100	mA
T_{stg}	Storage temperature range		-65 to +150	°C
P_{TOT}	Power dissipation per package – plastic mini-pack (SO) – plastic shrink mini-pack (SSOP and TSSOP)	above +70°C derate linearly with 8 mW/K	500	mW
		above +60°C derate linearly with 5.5 mW/K	500	

NOTES:

- Stresses beyond those listed may cause permanent damage to the device. These are stress ratings only and functional operation of the device at these or any other conditions beyond those indicated under "recommended operating conditions" is not implied. Exposure to absolute-maximum-rated conditions for extended periods may affect device reliability.
- The input and output voltage ratings may be exceeded if the input and output current ratings are observed.

DC ELECTRICAL CHARACTERISTICS

Over recommended operating conditions voltages are referenced to GND (ground = 0V)

SYMBOL	PARAMETER	TEST CONDITIONS	LIMITS			UNIT
			Temp = -40°C to +85°C			
			MIN	TYP ¹	MAX	
V_{IH}	HIGH level Input voltage	$V_{CC} = 1.2V$	V_{CC}			V
		$V_{CC} = 2.7$ to $3.6V$	2.0			
V_{IL}	LOW level Input voltage	$V_{CC} = 1.2V$			GND	V
		$V_{CC} = 2.7$ to $3.6V$			0.8	
V_{OH}	HIGH level output voltage	$V_{CC} = 2.7V; V_I = V_{IH}$ or $V_{IL}; I_O = -12mA$	$V_{CC} - 0.5$			V
		$V_{CC} = 3.0V; V_I = V_{IH}$ or $V_{IL}; I_O = -100\mu A$	$V_{CC} - 0.2$	V_{CC}		
		$V_{CC} = 3.0V; V_I = V_{IH}$ or $V_{IL}; I_O = -12mA$	$V_{CC} - 0.6$			
		$V_{CC} = 3.0V; V_I = V_{IH}$ or $V_{IL}; I_O = -24mA$	$V_{CC} - 1.0$			
V_{OL}	LOW level output voltage	$V_{CC} = 2.7V; V_I = V_{IH}$ or $V_{IL}; I_O = 12mA$			0.40	V
		$V_{CC} = 3.0V; V_I = V_{IH}$ or $V_{IL}; I_O = 100\mu A$			0.20	
		$V_{CC} = 3.0V; V_I = V_{IH}$ or $V_{IL}; I_O = 24mA$			0.55	
I_I	Input leakage current	$V_{CC} = 3.6V; V_I = 5.5V$ or GND		± 0.1	± 5	μA
I_{OZ}	3-State output OFF-state current	$V_{CC} = 3.6V; V_I = V_{IH}$ or $V_{IL}; V_O = V_{CC}$ or GND		0.1	± 10	μA
I_{CC}	Quiescent supply current	$V_{CC} = 3.6V; V_I = V_{CC}$ or GND; $I_O = 0$		0.1	10	μA
ΔI_{CC}	Additional quiescent supply current	$V_{CC} = 2.7V$ to $3.6V; V_I = V_{CC} - 0.6V; I_O = 0$		5	500	μA

NOTE:

- All typical values are at $V_{CC} = 3.3V$ and $T_{amb} = 25^\circ C$.

Octal D-type flip-flop with reset; positive-edge trigger

74LVC273

AC CHARACTERISTICS

GND = 0V; $t_R = t_F = 2.5\text{ns}$; $C_L = 50\text{pF}$; $R_L = 500\Omega$; $T_{\text{amb}} = -40^\circ\text{C}$ to $+85^\circ\text{C}$.

SYMBOL	PARAMETER	WAVEFORM	LIMITS						UNIT
			$V_{CC} = 3.3V \pm 0.3V$			$V_{CC} = 2.7V$			
			MIN	TYP ¹	MAX	MIN	TYP	MAX	
t_{PHL} t_{PLH}	Propagation delay CP to Qn	1		6.0	10.2		6.6	11.2	ns
t_{PHL}	Propagation delay MR to Qn	2		6.3	11.0		7.4	12.0	ns
t_W	Clock pulse width HIGH or LOW	1	4	1.2		5	1.8		ns
t_W	Master reset pulse width LOW	2	4	1.2		5	1.7		ns
t_{rem}	Removal time MR to CP	2	2	-1.0		3	-1.0		ns
t_{su}	Set-up time D_n to CP	3	2	0.7		3	1.0		ns
t_h	Hold time D_n to CP	3	0	-0.6		0	-0.9		ns
f_{max}	Maximum clock pulse frequency	1	125			100			MHz

NOTE:

1. These typical values are at $V_{CC} = 3.3V$ and $T_{\text{amb}} = 25^\circ\text{C}$.

AC WAVEFORMS

$V_M = 1.5V$ at $V_{CC} \geq 2.7V$.

$V_M = 0.5 V_{CC}$ at $V_{CC} < 2.7V$.

V_{OL} and V_{OH} are the typical output voltage drop that occur with the output load.

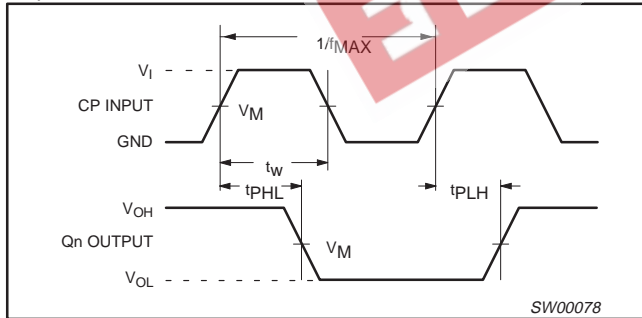

Waveform 1. Clock (CP) to output (Qn) propagation delays, the clock pulse width and the maximum clock pulse frequency

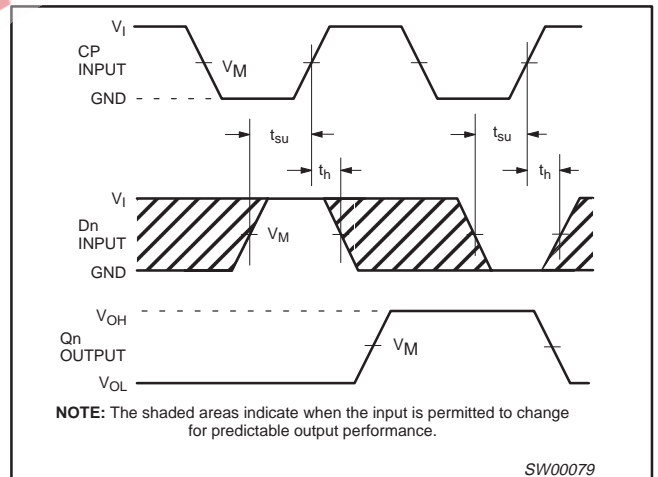

Waveform 3. Data set-up and hold times for the data input (Dn)

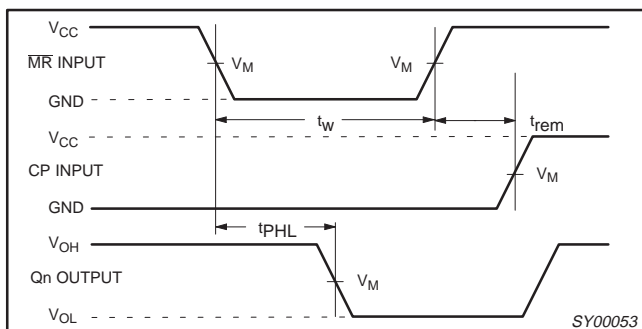

Waveform 2. Master reset (MR) pulse width, the master reset to output (Qn) propagation delays and the master reset to clock (CP) removal time

Octal D-type flip-flop with reset; positive-edge trigger

74LVC273

TEST CIRCUIT

Test Circuit for 3-State Outputs

Switch position

TEST	S ₁	V _{CC}	V _I	V _{S1}
t _{PLH} /t _{PHL}	Open	< 2.7V	V _{CC}	2 * V _{CC}
t _{PLZ} /t _{PZL}	V _{S1}	2.7-3.6V	2.7V	2 * V _{CC}
t _{PHZ} /t _{PZH}	GND			

DEFINITIONS

R_L = Load resistor; see AC CHARACTERISTICS for value.

C_L = Load capacitance includes jig and probe capacitance; See AC CHARACTERISTICS for value.

R_T = Termination resistance should be equal to Z_{OUT} of pulse generators.

V_M = 1.5V
Input Pulse Definition

SY00044

Waveform 4. Load circuitry for switching times

Octal D-type flip-flop with reset; positive-edge trigger

74LVC273

SO20: plastic small outline package; 20 leads; body width 7.5 mm

SOT163-1

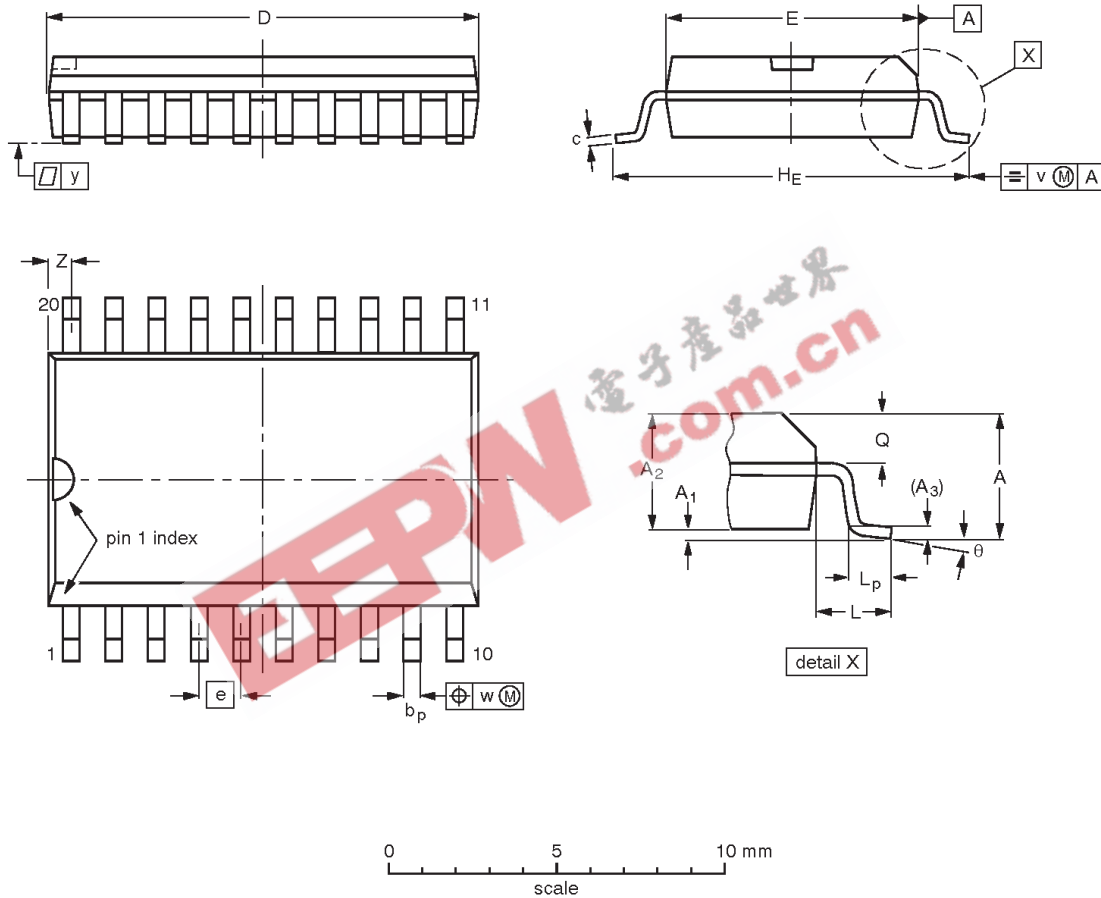

DIMENSIONS (inch dimensions are derived from the original mm dimensions)

UNIT	A max.	A ₁	A ₂	A ₃	b _p	c	D ⁽¹⁾	E ⁽¹⁾	e	H _E	L	L _p	Q	v	w	y	Z ⁽¹⁾	θ
mm	2.65	0.30 0.10	2.45 2.25	0.25	0.49 0.36	0.32 0.23	13.0 12.6	7.6 7.4	1.27	10.65 10.00	1.4	1.1 0.4	1.1 1.0	0.25	0.25	0.1	0.9 0.4	8° 0°
inches	0.10	0.012 0.004	0.096 0.089	0.01	0.019 0.014	0.013 0.009	0.51 0.49	0.30 0.29	0.050	0.42 0.39	0.055	0.043 0.016	0.043 0.039	0.01	0.01	0.004	0.035 0.016	

Note

1. Plastic or metal protrusions of 0.15 mm maximum per side are not included.

OUTLINE VERSION	REFERENCES				EUROPEAN PROJECTION	ISSUE DATE
	IEC	JEDEC	EIAJ			
SOT163-1	075E04	MS-013AC				92-11-17 95-01-24

Octal D-type flip-flop with reset; positive-edge trigger

74LVC273

SSOP20: plastic shrink small outline package; 20 leads; body width 5.3 mm

SOT339-1

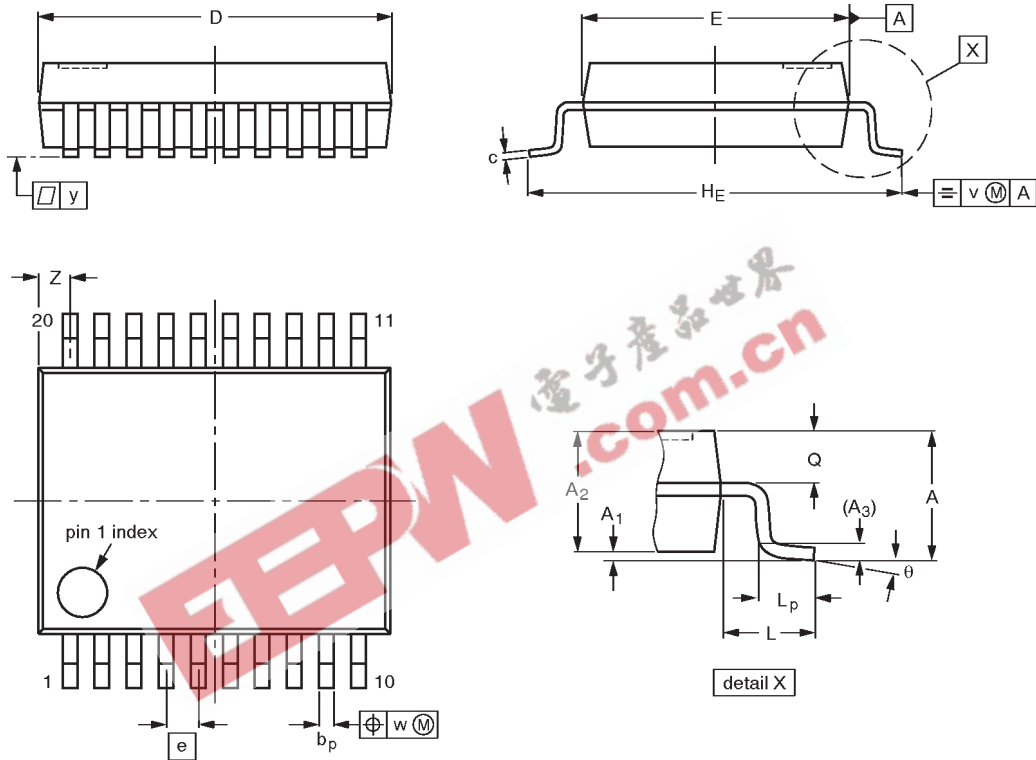

DIMENSIONS (mm are the original dimensions)

UNIT	A max.	A ₁	A ₂	A ₃	b _p	c	D ⁽¹⁾	E ⁽¹⁾	e	H _E	L	L _p	Q	v	w	y	z ⁽¹⁾	θ
mm	2.0	0.21 0.05	1.80 1.65	0.25	0.38 0.25	0.20 0.09	7.4 7.0	5.4 5.2	0.65	7.9 7.6	1.25	1.03 0.63	0.9 0.7	0.2	0.13	0.1	0.9 0.5	8° 0°

Note

1. Plastic or metal protrusions of 0.20 mm maximum per side are not included.

OUTLINE VERSION	REFERENCES				EUROPEAN PROJECTION	ISSUE DATE
	IEC	JEDEC	EIAJ			
SOT339-1		MO-150AE				93-09-08 95-02-04

Octal D-type flip-flop with reset; positive-edge trigger

74LVC273

TSSOP20: plastic thin shrink small outline package; 20 leads; body width 4.4 mm

SOT360-1

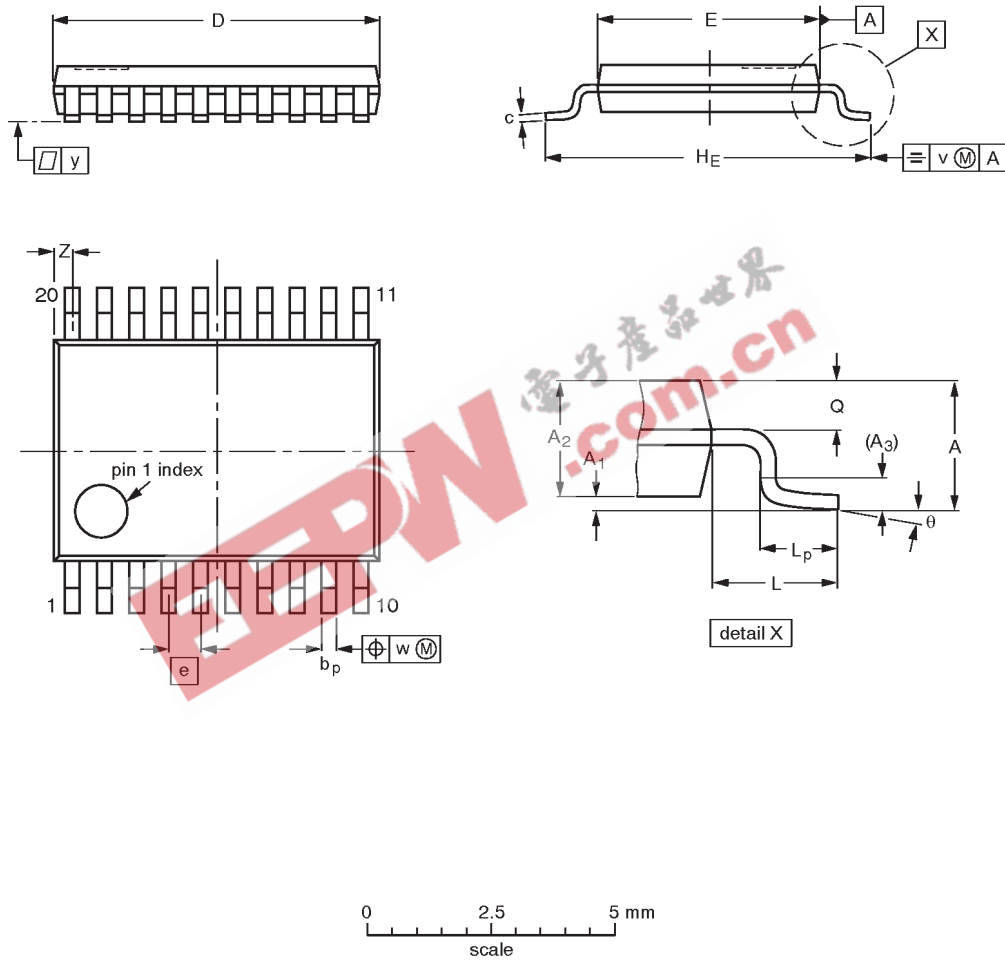

DIMENSIONS (mm are the original dimensions)

UNIT	A max.	A ₁	A ₂	A ₃	b _p	c	D ⁽¹⁾	E ⁽²⁾	e	H _E	L	L _p	Q	v	w	y	Z ⁽¹⁾	θ
mm	1.10	0.15 0.05	0.95 0.80	0.25	0.30 0.19	0.2 0.1	6.6 6.4	4.5 4.3	0.65	6.6 6.2	1.0	0.75 0.50	0.4 0.3	0.2	0.13	0.1	0.5 0.2	8° 0°

Notes

1. Plastic or metal protrusions of 0.15 mm maximum per side are not included.
2. Plastic interlead protrusions of 0.25 mm maximum per side are not included.

OUTLINE VERSION	REFERENCES				EUROPEAN PROJECTION	ISSUE DATE
	IEC	JEDEC	EIAJ			
SOT360-1		MO-153AC				93-06-16 95-02-04

Octal D-type flip-flop with reset; positive-edge trigger

74LVC273

DEFINITIONS

Data Sheet Identification	Product Status	Definition
<i>Objective Specification</i>	Formative or in Design	This data sheet contains the design target or goal specifications for product development. Specifications may change in any manner without notice.
<i>Preliminary Specification</i>	Preproduction Product	This data sheet contains preliminary data, and supplementary data will be published at a later date. Philips Semiconductors reserves the right to make changes at any time without notice in order to improve design and supply the best possible product.
<i>Product Specification</i>	Full Production	This data sheet contains Final Specifications. Philips Semiconductors reserves the right to make changes at any time without notice, in order to improve design and supply the best possible product.

Philips Semiconductors and Philips Electronics North America Corporation reserve the right to make changes, without notice, in the products, including circuits, standard cells, and/or software, described or contained herein in order to improve design and/or performance. Philips Semiconductors assumes no responsibility or liability for the use of any of these products, conveys no license or title under any patent, copyright, or mask work right to these products, and makes no representations or warranties that these products are free from patent, copyright, or mask work right infringement, unless otherwise specified. Applications that are described herein for any of these products are for illustrative purposes only. Philips Semiconductors makes no representation or warranty that such applications will be suitable for the specified use without further testing or modification.

LIFE SUPPORT APPLICATIONS

Philips Semiconductors and Philips Electronics North America Corporation Products are not designed for use in life support appliances, devices, or systems where malfunction of a Philips Semiconductors and Philips Electronics North America Corporation Product can reasonably be expected to result in a personal injury. Philips Semiconductors and Philips Electronics North America Corporation customers using or selling Philips Semiconductors and Philips Electronics North America Corporation Products for use in such applications do so at their own risk and agree to fully indemnify Philips Semiconductors and Philips Electronics North America Corporation for any damages resulting from such improper use or sale.

Philips Semiconductors
811 East Arques Avenue
P.O. Box 3409
Sunnyvale, California 94088-3409
Telephone 800-234-7381

Philips Semiconductors and Philips Electronics North America Corporation register eligible circuits under the Semiconductor Chip Protection Act.
 © Copyright Philips Electronics North America Corporation 1998
 All rights reserved. Printed in U.S.A.

print code

Date of release: 05-96

Document order number:

9397-750-04505

Let's make things better.