

# DATA SHEET

For a complete data sheet, please also download:

- The IC06 74HC/HCT/HCU/HCMOS Logic Family Specifications
- The IC06 74HC/HCT/HCU/HCMOS Logic Package Information
- The IC06 74HC/HCT/HCU/HCMOS Logic Package Outlines

EEPW 电子产品世界  
.com.cn

## 74HC/HCT4016 Quad bilateral switches

Product specification  
File under Integrated Circuits, IC06

December 1990

## Quad bilateral switches

## 74HC/HCT4016

## FEATURES

- Low "ON" resistance:  
160  $\Omega$  (typ.) at  $V_{CC} = 4.5$  V  
120  $\Omega$  (typ.) at  $V_{CC} = 6.0$  V  
80  $\Omega$  (typ.) at  $V_{CC} = 9.0$  V
- Individual switch controls
- Typical "break before make" built in
- Output capability: non-standard
- $I_{CC}$  category: SSI

## GENERAL DESCRIPTION

The 74HC/HCT4016 are high-speed Si-gate CMOS devices and are pin compatible with the "4016" of the

"4000B" series. They are specified in compliance with JEDEC standard no. 7A.

The 74HC/HCT4016 have four independent analog switches (transmission gates).

Each switch has two input/output terminals ( $Y_n$ ,  $Z_n$ ) and an active HIGH enable input ( $E_n$ ). When  $E_n$  is connected to  $V_{CC}$ , a low bidirectional path between  $Y_n$  and  $Z_n$  is established (ON condition). When  $E_n$  is connected to ground (GND), the switch is disabled and a high impedance between  $Y_n$  and  $Z_n$  is established (OFF condition).

Current through a switch will not cause additional  $V_{CC}$  current provided the voltage at the terminals of the switch is maintained within the supply voltage range;  $V_{CC} \gg (V_Y, V_Z) \gg$  GND. Inputs  $Y_n$  and  $Z_n$  are electrically equivalent terminals.

## QUICK REFERENCE DATA

GND = 0 V;  $T_{amb} = 25$  °C;  $t_r = t_f = 6$  ns

SYMBOL	PARAMETER	CONDITIONS	TYPICAL		UNIT
			HC	HCT	
$t_{PZH}/t_{PZL}$	turn "ON" time $E_n$ to $V_{OS}$	$C_L = 15$ pF; $R_L = 1$ k $\Omega$ ; $V_{CC} = 5$ V	16	17	ns
$t_{PHZ}/t_{PLZ}$	turn "OFF" time $E_n$ to $V_{OS}$		14	20	ns
$C_I$	input capacitance		3.5	3.5	pF
$C_{PD}$	power dissipation capacitance per switch	notes 1 and 2	12	12	pF
$C_S$	max. switch capacitance		5	5	pF

## Notes

1.  $C_{PD}$  is used to determine the dynamic power dissipation ( $P_D$  in  $\mu$ W):

$$P_D = C_{PD} \times V_{CC}^2 \times f_i + \sum \{ (C_L + C_S) \times V_{CC}^2 \times f_o \} \text{ where:}$$

$f_i$  = input frequency in MHz

$f_o$  = output frequency in MHz

$\sum \{ (C_L + C_S) \times V_{CC}^2 \times f_o \}$  = sum of outputs

$C_L$  = output load capacitance in pF

$C_S$  = max. switch capacitance in pF

$V_{CC}$  = supply voltage in V

2. For HC the condition is  $V_I =$  GND to  $V_{CC}$   
For HCT the condition is  $V_I =$  GND to  $V_{CC} - 1.5$  V

## ORDERING INFORMATION

See "74HC/HCT/HCU/HCMOS Logic Package Information".

Quad bilateral switches

74HC/HCT4016

PIN DESCRIPTION

PIN NO.	SYMBOL	NAME AND FUNCTION
1, 4, 8, 11	$Y_0$ to $Y_3$	independent inputs/outputs
7	GND	ground (0 V)
2, 3, 9, 10	$Z_0$ to $Z_3$	independent inputs/outputs
13, 5, 6, 12	$E_0$ to $E_3$	enable inputs (active HIGH)
14	$V_{CC}$	positive supply voltage

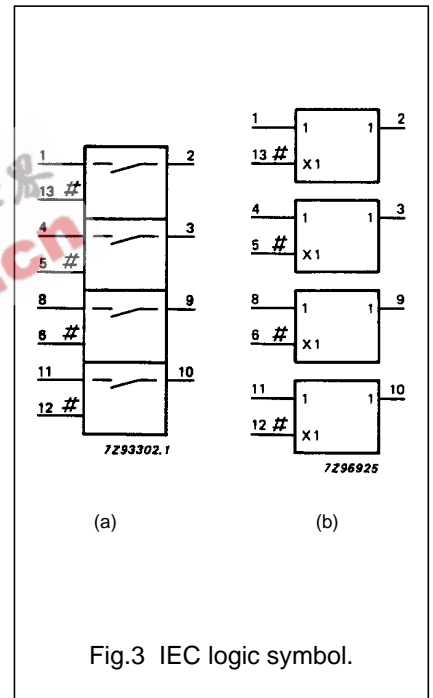
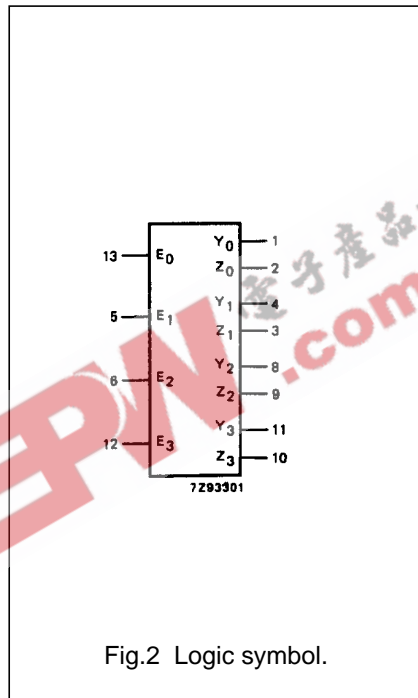
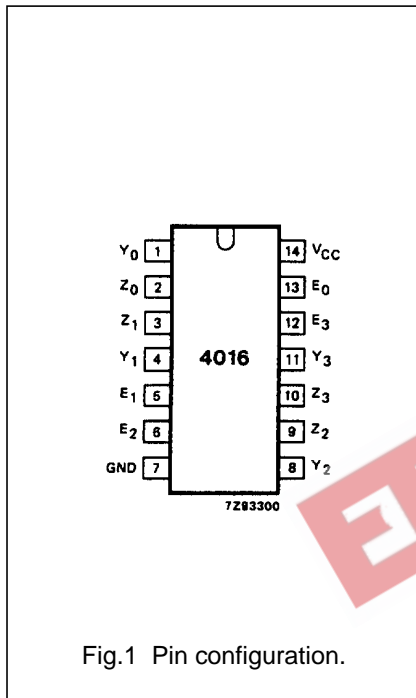

Quad bilateral switches

74HC/HCT4016

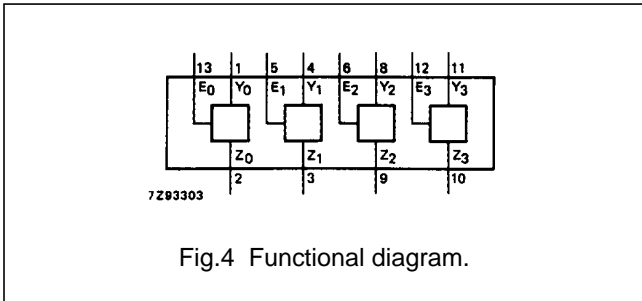

APPLICATIONS

- Signal gating
- Modulation
- Demodulation
- Chopper

FUNCTION TABLE

INPUT E <sub>n</sub>	CHANNEL IMPEDANCE
L	high
H	low

Notes

1. H = HIGH voltage level  
L = LOW voltage level

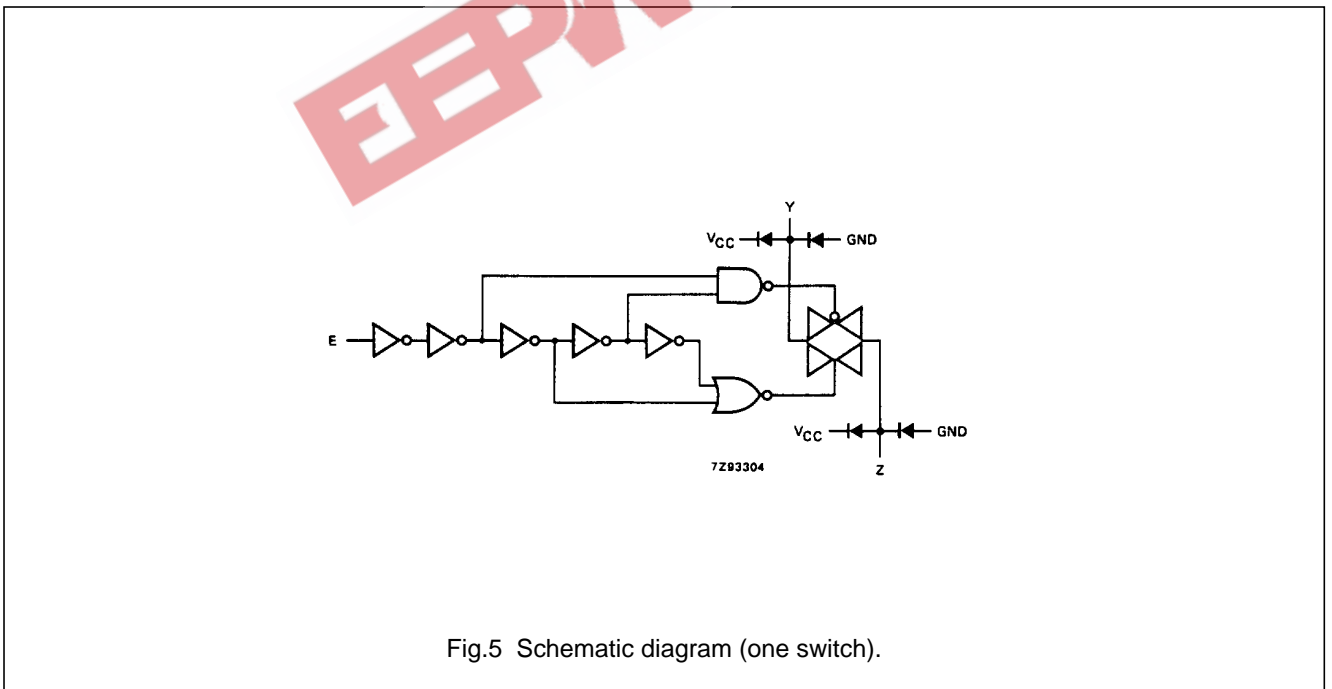

## Quad bilateral switches

## 74HC/HCT4016

**RATINGS**

Limiting values in accordance with the Absolute Maximum System (IEC 134)

Voltages are referenced to GND (ground = 0 V)

SYMBOL	PARAMETER	MIN.	MAX.	UNIT	CONDITIONS
$V_{CC}$	DC supply voltage	-0.5	+11.0	V	
$\pm I_{IK}$	DC digital input diode current		20	mA	for $V_I < -0.5$ V or $V_I > V_{CC} + 0.5$ V
$\pm I_{SK}$	DC switch diode current		20	mA	for $V_S < -0.5$ V or $V_S > V_{CC} + 0.5$ V
$\pm I_S$	DC switch current		25	mA	for $-0.5$ V $< V_S < V_{CC} + 0.5$ V
$\pm I_{CC}; \pm I_{GND}$	DC $V_{CC}$ or GND current		50	mA	
$T_{stg}$	storage temperature range	-65	+150	°C	
$P_{tot}$	power dissipation per package				for temperature range: -40 to +125 °C 74HC/HCT
	plastic DIL		750	mW	above +70 °C: derate linearly with 12 mW/K
	plastic mini-pack (SO)		500	mW	above +70 °C: derate linearly with 8 mW/K
$P_S$	power dissipation per switch		100	mW	

**RECOMMENDED OPERATING CONDITIONS**

SYMBOL	PARAMETER	74HC			74HCT			UNIT	CONDITIONS
		min.	typ.	max.	min.	typ.	max.		
$V_{CC}$	DC supply voltage	2.0	5.0	10.0	4.5	5.0	5.5	V	
$V_I$	DC input voltage range	GND		$V_{CC}$	GND		$V_{CC}$	V	
$V_S$	DC switch voltage range	GND		$V_{CC}$	GND		$V_{CC}$	V	
$T_{amb}$	operating ambient temperature range	-40		+85	-40		+85	°C	see DC and AC CHARACTERISTICS
$T_{amb}$	operating ambient temperature range	-40		+125	-40		+125	°C	
$t_r, t_f$	input rise and fall times		6.0	1000 500 400 250		6.0	500	ns	$V_{CC} = 2.0$ V $V_{CC} = 4.5$ V $V_{CC} = 6.0$ V $V_{CC} = 10.0$ V

Quad bilateral switches

74HC/HCT4016

DC CHARACTERISTICS FOR 74HC/HCT

For 74HC:  $V_{CC} = 2.0, 4.5, 6.0$  and  $9.0$  V

For 74HCT:  $V_{CC} = 4.5$  V

SYMBOL	PARAMETER	$T_{amb}$ (°C)						UNIT	TEST CONDITIONS				
		74HC/HCT							$V_{CC}$ (V)	$I_S$ ( $\mu$ A)	$V_{is}$	$V_I$	
		+25			-40 to +85		-40 to +125						
		min.	typ.	max.	min.	max.	min.						max.
$R_{ON}$	ON resistance (peak)		–	–		–		–	$\Omega$	2.0	100	$V_{CC}$ to GND	$V_{IH}$ or $V_{IL}$
			160	320		400		480	$\Omega$	4.5	1000		
			120	240		300		360	$\Omega$	6.0	1000		
			85	170		213		255	$\Omega$	9.0	1000		
$R_{ON}$	ON resistance (rail)		160	–		–		–	$\Omega$	2.0	100	GND	$V_{IH}$ or $V_{IL}$
			80	160		200		240	$\Omega$	4.5	1000		
			70	140		175		210	$\Omega$	6.0	1000		
			60	120		150		180	$\Omega$	9.0	1000		
$R_{ON}$	ON resistance (rail)		170	–		–		–	$\Omega$	2.0	100	$V_{CC}$	$V_{IH}$ or $V_{IL}$
			90	180		225		270	$\Omega$	4.5	1000		
			80	160		200		240	$\Omega$	6.0	1000		
			65	135		170		205	$\Omega$	9.0	1000		
$\Delta R_{ON}$	maximum $\Delta ON$ resistance between any two channels		–						$\Omega$	2.0		$V_{CC}$ to GND	$V_{IH}$ or $V_{IL}$
			16						$\Omega$	4.5			
			12						$\Omega$	6.0			
			9						$\Omega$	9.0			

Notes to the DC Characteristics

- At supply voltages approaching 2.0 V the analog switch ON-resistance becomes extremely non-linear. Therefore it is recommended that these devices be used to transmit digital signals only, when using these supply voltages.
- For test circuit measuring  $R_{ON}$  see Fig.6.

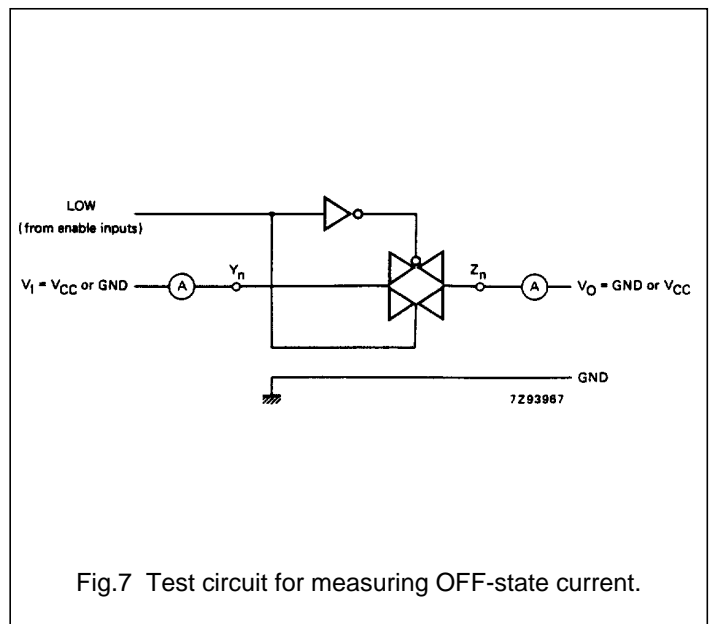
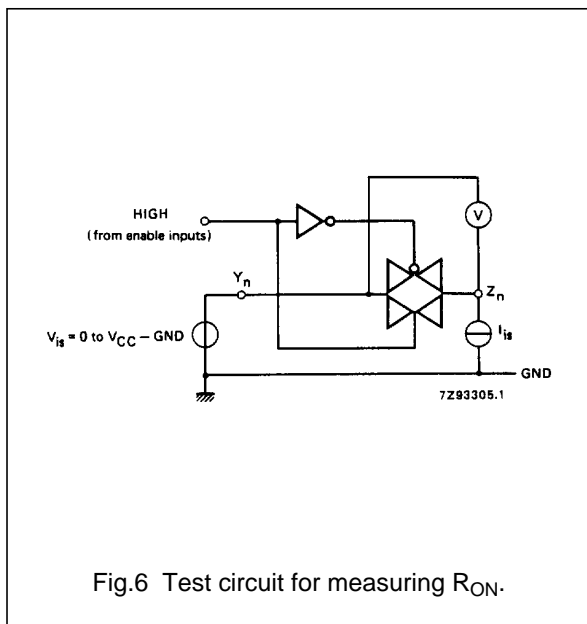

Quad bilateral switches

74HC/HCT4016

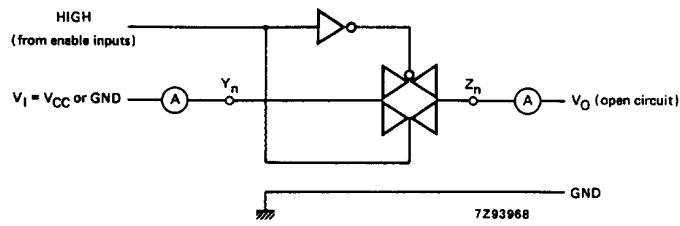

Fig.8 Test circuit for measuring ON-state current.

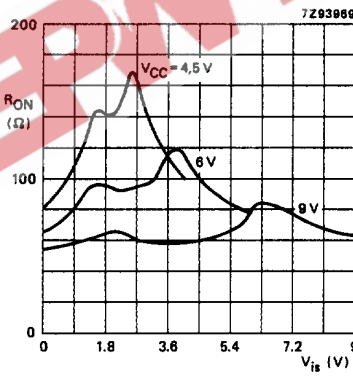

Fig.9 Typical  $R_{ON}$  as a function of input voltage  $V_{is}$  for  $V_{is} = 0$  to  $V_{CC}$ .

## Quad bilateral switches

## 74HC/HCT4016

## DC CHARACTERISTICS FOR 74HC

Voltages are referenced to GND (ground = 0 V)

SYMBOL	PARAMETER	T <sub>amb</sub> (°C)								UNIT	TEST CONDITIONS		
		74HC									V <sub>CC</sub> (V)	V <sub>I</sub>	OTHER
		+25			-40 to +85		-40 to +125						
		min.	typ.	max.	min.	max.	min.	max.					
V <sub>IH</sub>	HIGH level input voltage	1.5	1.2		1.5		1.5		V	2.0			
		3.15	2.4		3.15		3.15			4.5			
		4.2	3.2		4.2		4.2			6.0			
		6.3	4.3		6.3		6.3			9.0			
V <sub>IL</sub>	LOW level input voltage		0.8	0.50		0.50		0.50	V	2.0			
			2.1	1.35		1.35		1.35		4.5			
			2.8	1.80		1.80		1.80		6.0			
			4.3	2.70		2.70		2.70		9.0			
±I <sub>I</sub>	input leakage current			0.1		1.0		1.0	μA	6.0	V <sub>CC</sub> or GND		
				0.2		2.0		2.0		10.0			
±I <sub>S</sub>	analog switch OFF-state current per channel			0.1		1.0		1.0	μA	10.0	V <sub>IH</sub> or V <sub>IL</sub>	V <sub>S</sub>   = V <sub>CC</sub> - GND (see Fig.7)	
±I <sub>S</sub>	analog switch ON-state current			0.1		1.0		1.0	μA	10.0	V <sub>IH</sub> or V <sub>IL</sub>	V <sub>S</sub>   = V <sub>CC</sub> - GND (see Fig.8)	
I <sub>CC</sub>	quiescent supply current			2.0		20.0		40.0	μA	6.0	V <sub>CC</sub> or GND	V <sub>IS</sub> = GND or V <sub>CC</sub> ; V <sub>OS</sub> = V <sub>CC</sub> or GND	
				4.0		40.0		80.0		10.0			

## AC CHARACTERISTICS FOR 74HC

GND = 0 V; t<sub>r</sub> = t<sub>f</sub> = 6 ns; C<sub>L</sub> = 50 pF

SYMBOL	PARAMETER	T <sub>amb</sub> (°C)								UNIT	TEST CONDITIONS	
		74HC									V <sub>CC</sub> (V)	OTHER
		+25			-40 to +85		-40 to +125					
		min.	typ.	max.	min.	max.	min.	max.				
t <sub>PHL</sub> / t <sub>PLH</sub>	propagation delay V <sub>IS</sub> to V <sub>OS</sub>		17	60		75		90	ns	2.0	R <sub>L</sub> = ∞; C <sub>L</sub> = 50 pF (see Fig.16)	
			6	12		15		18		4.5		
			5	10		13		15		6.0		
			4	8		10		12		9.0		
t <sub>PZH</sub> / t <sub>PZL</sub>	turn "ON" time E <sub>n</sub> to V <sub>OS</sub>		52	190		240		235	ns	2.0	R <sub>L</sub> = 1 kΩ; C <sub>L</sub> = 50 pF (see Figs 17 and 18)	
			19	38		48		57		4.5		
			15	32		41		48		6.0		
			11	28		35		42		9.0		
t <sub>PHZ</sub> / t <sub>PLZ</sub>	turn "OFF" time E <sub>n</sub> to V <sub>OS</sub>		47	145		180		220	ns	2.0	R <sub>L</sub> = 1 kΩ; C <sub>L</sub> = 50 pF (see Figs 17 and 18)	
			17	29		36		44		4.5		
			14	25		31		38		6.0		
			13	22		28		33		9.0		



## Quad bilateral switches

## 74HC/HCT4016

## DC CHARACTERISTICS FOR 74HCT

Voltages are referenced to GND (ground = 0 V)

SYMBOL	PARAMETER	T <sub>amb</sub> (°C)								UNIT	TEST CONDITIONS		
		74HCT									V <sub>CC</sub> (V)	V <sub>I</sub>	OTHER
		+25			-40 to +85		-40 to +125						
		min.	typ.	max.	min.	max.	min.	max.					
V <sub>IH</sub>	HIGH level input voltage	2.0	1.6		2.0		2.0		V	4.5 to 5.5			
V <sub>IL</sub>	LOW level input voltage		1.2	0.8		0.8		0.8	V	4.5 to 5.5			
±I <sub>I</sub>	input leakage current			0.1		1.0		1.0	μA	5.5	V <sub>CC</sub> or GND		
±I <sub>S</sub>	analog switch OFF-state current per channel			0.1		1.0		1.0	μA	5.5	V <sub>IH</sub> or V <sub>IL</sub>	V <sub>S</sub>   = V <sub>CC</sub> - GND (see Fig.7)	
±I <sub>S</sub>	analog switch ON-state current			0.1		1.0		1.0	μA	5.5	V <sub>IH</sub> or V <sub>IL</sub>	V <sub>S</sub>   = V <sub>CC</sub> - GND (see Fig.8)	
I <sub>CC</sub>	quiescent supply current		2.0		20.0		40.0		μA	4.5 to 5.5	V <sub>CC</sub> or GND	V <sub>is</sub> = GND or V <sub>CC</sub> ; V <sub>os</sub> = V <sub>CC</sub> or GND	
ΔI <sub>CC</sub>	additional quiescent supply current per input pin for unit load coefficient is 1 (note 1)		100	360		450		490	μA	4.5 to 5.5	V <sub>CC</sub> -2.1V	other inputs at V <sub>CC</sub> or GND	

## Note

- The value of additional quiescent supply current (ΔI<sub>CC</sub>) for a unit load of 1 is given here. To determine ΔI<sub>CC</sub> per input, multiply this value by the unit load coefficient shown in the table below.

INPUT	UNIT LOAD COEFFICIENT
E <sub>N</sub>	1.00

## Quad bilateral switches

## 74HC/HCT4016

## AC CHARACTERISTICS FOR 74HCT

GND = 0 V;  $t_r = t_f = 6$  ns;  $C_L = 50$  pF

SYMBOL	PARAMETER	$T_{amb}$ (°C)						UNIT	TEST CONDITIONS		
		74HCT							$V_{CC}$ (V)	OTHER	
		+25			-40 to +85		-40 to +125				
		min.	typ.	max.	min.	max.	min.				max.
$t_{PHL}/t_{PLH}$	propagation delay $V_{is}$ to $V_{os}$		6	12		15		18	ns	4.5	$R_L = \infty$ ; $C_L = 50$ pF (see Fig.16)
$t_{PZH}$	turn "ON" time $E_n$ to $V_{os}$		19	35		44		53	ns	4.5	$R_L = 1$ k $\Omega$ ; $C_L = 50$ pF (see Figs 17 and 18)
$t_{PZL}$	turn "ON" time $E_n$ to $V_{os}$		20	35		44		53	ns	4.5	$R_L = 1$ k $\Omega$ ; $C_L = 50$ pF (see Figs 17 and 18)
$t_{PHZ}/t_{PLZ}$	turn "OFF" time $E_n$ to $V_{os}$		23	35		44		53	ns	4.5	$R_L = 1$ k $\Omega$ ; $C_L = 50$ pF (see Figs 17 and 18)

## ADDITIONAL AC CHARACTERISTICS FOR 74HC/HCT

## Recommended conditions and typical values

GND = 0 V;  $t_r = t_f = 6$  ns

SYMBOL	PARAMETER	typ.	UNIT	$V_{CC}$ (V)	$V_{is(p-p)}$ (V)	CONDITIONS
	sine-wave distortion $f = 1$ kHz	0.80 0.40	% %	4.5 9.0	4.0 8.0	$R_L = 10$ k $\Omega$ ; $C_L = 50$ pF (see Fig.14)
	sine-wave distortion $f = 10$ kHz	2.40 1.20	% %	4.5 9.0	4.0 8.0	$R_L = 10$ k $\Omega$ ; $C_L = 50$ pF (see Fig.14)
	switch "OFF" signal feed-through	-50 -50	dB dB	4.5 9.0	note 3	$R_L = 600$ $\Omega$ ; $C_L = 50$ pF; $f = 1$ MHz (see Figs 10 and 15)
	crosstalk between any two switches	-60 -60	dB dB	4.5 9.0	note 3	$R_L = 600$ $\Omega$ ; $C_L = 50$ pF; $f = 1$ MHz (see Fig.12)
$V_{(p-p)}$	crosstalk voltage between enable or address input to any switch (peak-to-peak value)	110 220	mV mV	4.5 9.0		$R_L = 600$ $\Omega$ ; $C_L = 50$ pF; $f = 1$ MHz ( $E_n$ , square wave between $V_{CC}$ and GND, $t_r = t_f = 6$ ns) (see Fig.13)
$f_{max}$	minimum frequency response (-3dB)	150 160	MHz MHz	4.5 9.0	note 4	$R_L = 50$ $\Omega$ ; $C_L = 10$ pF (see Figs 11 and 14)
$C_S$	maximum switch capacitance	5	pF			

## Notes

- $V_{is}$  is the input voltage at a  $Y_n$  or  $Z_n$  terminal, whichever is assigned as an input.
- $V_{os}$  is the output voltage at a  $Y_n$  or  $Z_n$  terminal, whichever is assigned as an output.
- Adjust input voltage  $V_{is}$  to 0 dBm level (0 dBm = 1 mW into 600  $\Omega$ ).
- Adjust input voltage  $V_{is}$  to 0 dBm level at  $V_{os}$  for 1 MHz (0 dBm = 1 mW into 50  $\Omega$ ).

Quad bilateral switches

74HC/HCT4016

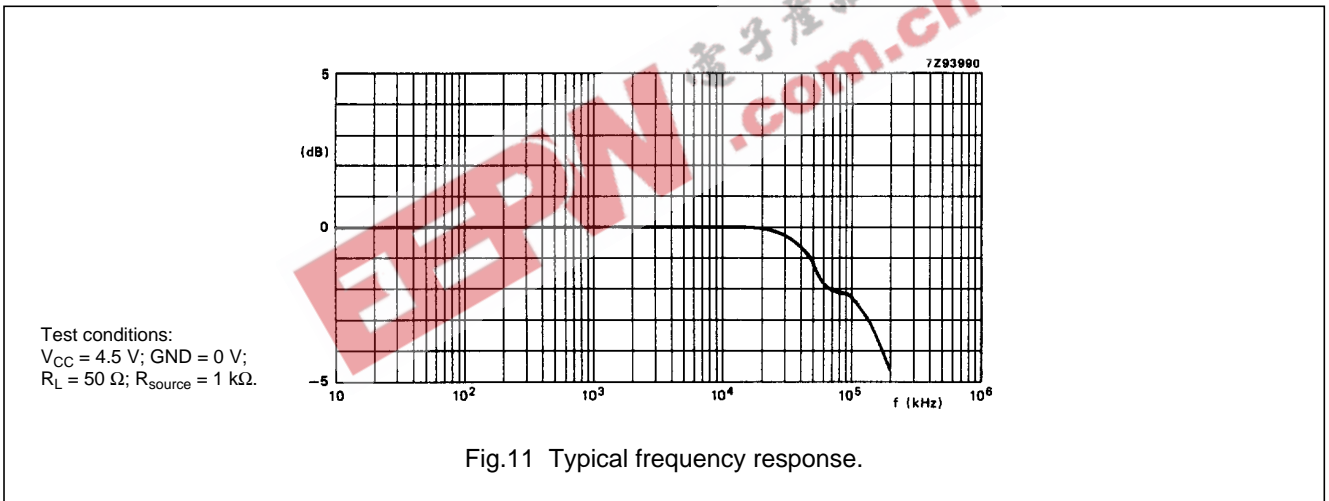
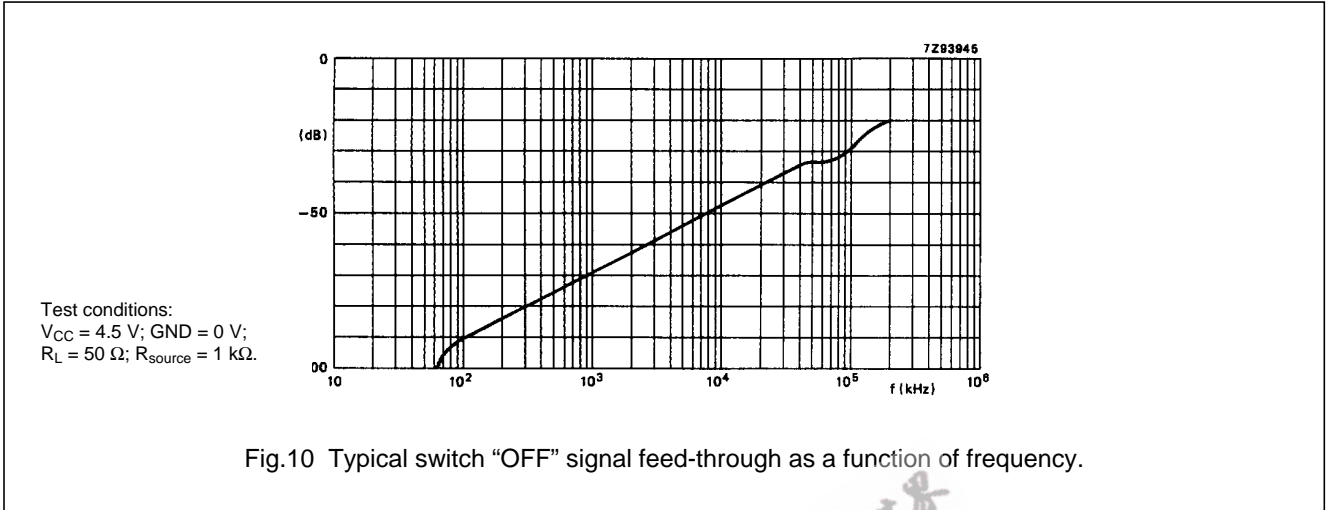

Quad bilateral switches

74HC/HCT4016

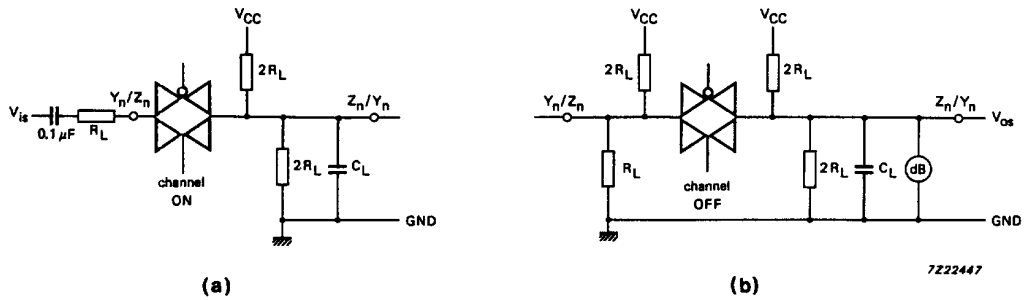

Fig. 12 Test circuit for measuring crosstalk between any two switches. (a) channel ON condition; (b) channel OFF condition.

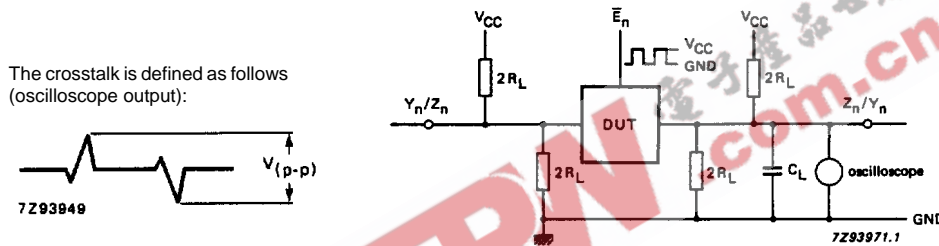

Fig. 13 Test circuit for measuring crosstalk between control and any switch.

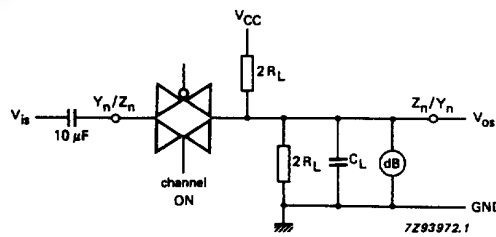

Fig. 14 Test circuit for measuring sine-wave distortion and minimum frequency response.

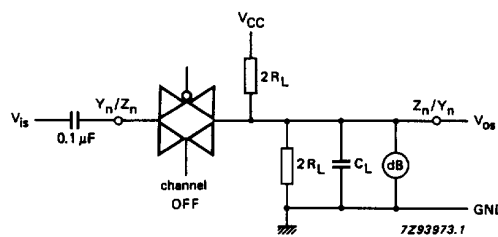

Fig. 15 Test circuit for measuring switch "OFF" signal feed-through.

Quad bilateral switches

74HC/HCT4016

AC WAVEFORMS

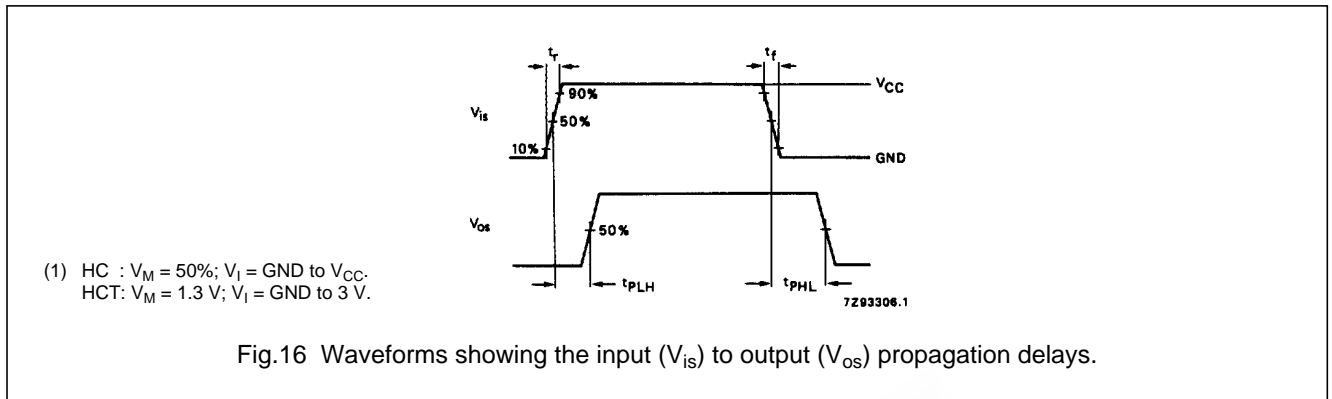

Fig.16 Waveforms showing the input ( $V_{is}$ ) to output ( $V_{os}$ ) propagation delays.

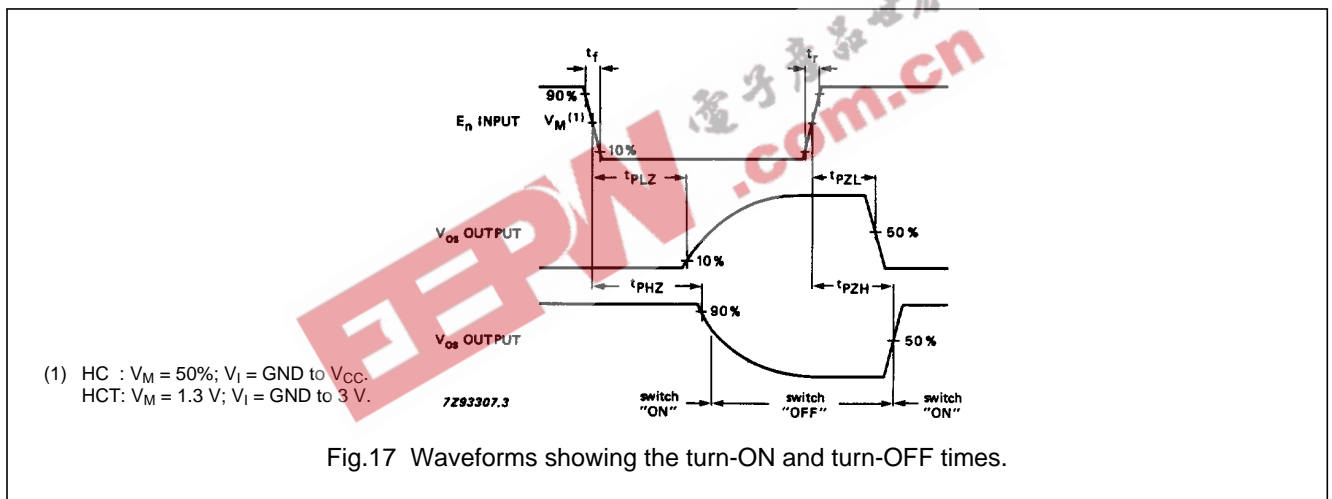

Fig.17 Waveforms showing the turn-ON and turn-OFF times.

Quad bilateral switches

74HC/HCT4016

TEST CIRCUIT AND WAVEFORMS

Conditions

TEST	SWITCH	V <sub>is</sub>
t <sub>PZH</sub>	GND	V <sub>CC</sub>
t <sub>PZL</sub>	V <sub>CC</sub>	GND
t <sub>PHZ</sub>	GND	V <sub>CC</sub>
t <sub>PLZ</sub>	V <sub>CC</sub>	GND
others	open	pulse

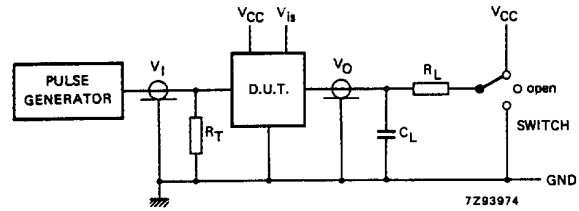

C<sub>L</sub> = load capacitance including jig and probe capacitance (see AC CHARACTERISTICS for values).  
 R<sub>T</sub> = termination resistance should be equal to the output impedance Z<sub>O</sub> of the pulse generator.  
 t<sub>r</sub> = t<sub>f</sub> = 6 ns; when measuring f<sub>max</sub>, there is no constraint t<sub>r</sub>, t<sub>f</sub> with 50% duty factor.

FAMILY	AMPLITUDE	V <sub>M</sub>	t <sub>r</sub> ; t <sub>f</sub>	
			f <sub>max</sub> ; PULSE WIDTH	OTHER
74HC	V <sub>CC</sub>	50%	< 2 ns	6 ns
74HCT	3.0 V	1.3 V	< 2 ns	6 ns

Fig.18 Test circuit for measuring AC performance.

C<sub>L</sub> = load capacitance including jig and probe capacitance (see AC CHARACTERISTICS for values).  
 R<sub>T</sub> = termination resistance should be equal to the output impedance Z<sub>O</sub> of the pulse generator.  
 t<sub>r</sub> = t<sub>f</sub> = 6 ns; when measuring f<sub>max</sub>, there is no constraint t<sub>r</sub>, t<sub>f</sub> with 50% duty factor.

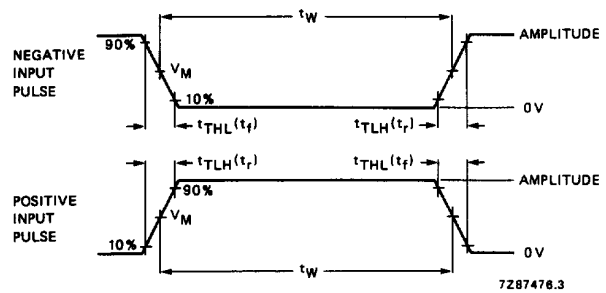

FAMILY	AMPLITUDE	V <sub>M</sub>	t <sub>r</sub> ; t <sub>f</sub>	
			f <sub>max</sub> ; PULSE WIDTH	OTHER
74HC	V <sub>CC</sub>	50%	< 2 ns	6 ns
74HCT	3.0 V	1.3 V	< 2 ns	6 ns

Fig.19 Input pulse definitions.

PACKAGE OUTLINES

See "74HC/HCT/HCU/HCMOS Logic Package Outlines".