



Integrated Device Technology, Inc.

FAST CMOS OCTAL REGISTERED TRANSCEIVERS

IDT29FCT52AT/BT/CT/DT
IDT29FCT2052AT/BT/CT
IDT29FCT53AT/BT/CT

FEATURES:

• Common features:

- Low input and output leakage $\leq 1\mu\text{A}$ (max.)
- CMOS power levels
- True TTL input and output compatibility
 - $V_{OH} = 3.3\text{V}$ (typ.)
 - $V_{OL} = 0.3\text{V}$ (typ.)
- Meets or exceeds JEDEC standard 18 specifications
- Product available in Radiation Tolerant and Radiation Enhanced versions
- Military product compliant to MIL-STD-883, Class B and DESC listed (dual marked)
- Available in DIP, SOIC, SSOP, QSOP, CERPACK and LCC packages

• Features for 29FCT52/29FCT53T:

- A, B, C and D speed grades
- High drive outputs (-15mA IOH, 64mA IOL)
- Power off disable outputs permit "live insertion"

• Features for 29FCT2052T:

- A, B and C speed grades
- Resistor outputs (-15mA IOH, 12mA IOL Com.)
(-12mA IOH, 12mA IOL Mil.)
- Reduced system switching noise

DESCRIPTION:

The IDT29FCT52AT/BT/CT/DT and IDT29FCT53AT/BT/CT are 8-bit registered transceivers built using an advanced dual metal CMOS technology. Two 8-bit back-to-back registers store data flowing in both directions between two bidirectional buses. Separate clock, clock enable and 3-state output enable signals are provided for each register. Both A outputs and B outputs are guaranteed to sink 64mA.

The IDT29FCT52AT/BT/CT/DT and IDT29FCT2052AT/BT/CT are non-inverting options of the IDT29FCT53AT/BT/CT.

The IDT29FCT2052AT/BT/CT has balanced drive outputs with current limiting resistors. This offers low ground bounce, minimal undershoot and controlled output fall times-reducing the need for external series terminating resistors. The IDT29FCT2052T part is a plug-in replacement for IDT29FCT52T part.

FUNCTIONAL BLOCK DIAGRAM⁽¹⁾



NOTE:

1. IDT29FCT52T/IDT29FCT2052T function is shown. IDT29FCT53T is the inverting option.

The IDT logo is a registered trademark of Integrated Device Technology, Inc.

2629 drw 01

MILITARY AND COMMERCIAL TEMPERATURE RANGES

JUNE 1995

PIN CONFIGURATIONS



**DIP/SOIC/SSOP/QSOP/CERPACK
TOP VIEW**

* For 29FCT52/29FCT2052AT/BT/CT only



**LCC
TOP VIEW**

PIN DESCRIPTION

Name	I/O	Description
A0-7	I/O	Eight bidirectional lines carrying the A Register inputs or B Register outputs.
B0-7	I/O	Eight bidirectional lines carrying the B Register inputs or A Register outputs.
CPA	I	Clock for the A Register. When CEA is LOW, data is entered into the A Register on the LOW-to-HIGH transition of the CPA signal.
$\overline{\text{CEA}}$	I	Clock Enable for the A Register. When $\overline{\text{CEA}}$ is LOW, data is entered into the A Register on the LOW-to-HIGH transition of the CPA signal. When $\overline{\text{CEA}}$ is HIGH, the A Register holds its contents, regardless of CPA signal transitions.
$\overline{\text{OEB}}$	I	Output Enable for the A Register. When $\overline{\text{OEB}}$ is LOW, the A Register outputs are enabled onto the B0-7 lines. When $\overline{\text{OEB}}$ is HIGH, the B0-7 outputs are in the high-impedance state.
CPB	I	Clock for the B Register. When CEB is LOW, data is entered into the B Register on the LOW-to-HIGH transition of the CPB signal.
$\overline{\text{CEB}}$	I	Clock Enable for the B Register. When $\overline{\text{CEB}}$ is LOW, data is entered into the B Register on the LOW-to-HIGH transition of the CPB signal. When $\overline{\text{CEB}}$ is HIGH, the B Register holds its contents, regardless of CPB signal transitions.
$\overline{\text{OEA}}$	I	Output Enable for the B Register. When $\overline{\text{OEA}}$ is LOW, the B Register outputs are enabled onto the A0-7 lines. When $\overline{\text{OEA}}$ is HIGH, the A0-7 outputs are in the high-impedance state.

2629 tbl 01

REGISTER FUNCTION TABLE⁽¹⁾ (Applies to A or B Register)

Inputs			Internal Q	Function
D	CP	\overline{CE}		
X	X	H	NC	Hold Data
L	↑	L	L	Load Data
H	↑	L	H	

NOTE:

- H = HIGH Voltage Level
L = LOW Voltage Level
X = Don't Care
NC = No Change
↑ = LOW-to-HIGH Transition

2629 tbl 02

OUTPUT CONTROL⁽¹⁾

\overline{OE}	Internal Q	Y-Outputs		Function
		52/2052	53	
H	X	Z	Z	Disable Outputs
L	L	L	H	Enable Outputs
L	H	H	L	

NOTE:

- H = HIGH Voltage Level
L = LOW Voltage Level
X = Don't Care
Z = High Impedance

2629 tbl 03

ABSOLUTE MAXIMUM RATINGS⁽¹⁾

Symbol	Rating	Commercial	Military	Unit
VTERM ⁽²⁾	Terminal Voltage with Respect to GND	-0.5 to +7.0	-0.5 to +7.0	V
VTERM ⁽³⁾	Terminal Voltage with Respect to GND	-0.5 to VCC +0.5	-0.5 to VCC +0.5	V
TA	Operating Temperature	0 to +70	-55 to +125	°C
TBIAS	Temperature Under Bias	-55 to +125	-65 to +135	°C
TSTG	Storage Temperature	-55 to +125	-65 to +150	°C
PT	Power Dissipation	0.5	0.5	W
IOUT	DC Output Current	-60 to +120	-60 to +120	mA

NOTES:

- Stresses greater than those listed under ABSOLUTE MAXIMUM RATINGS may cause permanent damage to the device. This is a stress rating only and functional operation of the device at these or any other conditions above those indicated in the operational sections of this specification is not implied. Exposure to absolute maximum rating conditions for extended periods may affect reliability. No terminal voltage may exceed VCC by +0.5V unless otherwise noted.
- Input and VCC terminals only.
- Outputs and I/O terminals only.

2529 lmk 04

CAPACITANCE (TA = +25°C, f = 1.0MHz)

Symbol	Parameter ⁽¹⁾	Conditions	Typ.	Max.	Unit
CIN	Input Capacitance	VIN = 0V	6	10	pF
COUT	Output Capacitance	VOU = 0V	8	12	pF

NOTE:

- This parameter is measured at characterization but not tested.

2640 lmk 05

DC ELECTRICAL CHARACTERISTICS OVER OPERATING RANGE

Following Conditions Apply Unless Otherwise Specified:

Commercial: $T_A = 0^\circ\text{C}$ to $+70^\circ\text{C}$, $V_{CC} = 5.0\text{V} \pm 5\%$; Military: $T_A = -55^\circ\text{C}$ to $+125^\circ\text{C}$, $V_{CC} = 5.0\text{V} \pm 10\%$

Symbol	Parameter	Test Conditions ⁽¹⁾		Min.	Typ. ⁽²⁾	Max.	Unit
V_{IH}	Input HIGH Level	Guaranteed Logic HIGH Level		2.0	—	—	V
V_{IL}	Input LOW Level	Guaranteed Logic LOW Level		—	—	0.8	V
I_{IH}	Input HIGH Current ⁽⁴⁾	$V_{CC} = \text{Max.}$	$V_I = 2.7\text{V}$	—	—	± 1	μA
I_{IL}	Input LOW Current ⁽⁴⁾		$V_I = 0.5\text{V}$	—	—	± 1	
I_{OZH}	High Impedance Output Current (3-State Output pins) ⁽⁴⁾	$V_{CC} = \text{Max.}$	$V_O = 2.7\text{V}$	—	—	± 1	μA
I_{OZL}			$V_O = 0.5\text{V}$	—	—	± 1	
I_I	Input HIGH Current ⁽⁴⁾	$V_{CC} = \text{Max.}, V_I = V_{CC} (\text{Max.})$		—	—	± 1	μA
V_{IK}	Clamp Diode Voltage	$V_{CC} = \text{Min.}, I_{IN} = -18\text{mA}$		—	-0.7	-1.2	V
V_H	Input Hysteresis	—		—	200	—	mV
I_{CC}	Quiescent Power Supply Current	$V_{CC} = \text{Max.}, V_{IN} = \text{GND or } V_{CC}$		—	0.01	1	mA

2629tbl06

OUTPUT DRIVE CHARACTERISTICS FOR 29FCT52T/29FCT53T

Symbol	Parameter	Test Conditions ⁽¹⁾		Min.	Typ. ⁽²⁾	Max.	Unit
V_{OH}	Output HIGH Voltage	$V_{CC} = \text{Min.}$ $V_{IN} = V_{IH} \text{ or } V_{IL}$	$I_{OH} = -6\text{mA MIL.}$	2.4	3.3	—	V
			$I_{OH} = -8\text{mA COM'L.}$	—	—	—	—
			$I_{OH} = -12\text{mA MIL.}$ $I_{OH} = -15\text{mA COM'L.}$	2.0	3.0	—	V
V_{OL}	Output LOW Voltage	$V_{CC} = \text{Min.}$ $V_{IN} = V_{IH} \text{ or } V_{IL}$	$I_{OL} = 48\text{mA MIL.}$	—	0.3	0.55	V
			$I_{OL} = 64\text{mA COM'L.}$	—	—	—	—
I_{OS}	Short Circuit Current	$V_{CC} = \text{Max.}, V_O = \text{GND}^{(3)}$		-60	-120	-225	mA
I_{OFF}	Input/Output Power Off Leakage ⁽⁵⁾	$V_{CC} = 0\text{V}, V_{IN} \text{ or } V_O \leq 4.5\text{V}$		—	—	± 1	μA

2629tbl07

OUTPUT DRIVE CHARACTERISTICS FOR 29FCT2052T

Symbol	Parameter	Test Conditions ⁽¹⁾		Min.	Typ. ⁽²⁾	Max.	Unit
I_{ODL}	Output LOW Current	$V_{CC} = 5\text{V}, V_{IN} = V_{IH} \text{ or } V_{IL}, V_{OUT} = 1.5\text{V}^{(3)}$		16	48	—	mA
I_{ODH}	Output HIGH Current	$V_{CC} = 5\text{V}, V_{IN} = V_{IH} \text{ or } V_{IL}, V_{OUT} = 1.5\text{V}^{(3)}$		-16	-48	—	mA
V_{OH}	Output HIGH Voltage	$V_{CC} = \text{Min.}$ $V_{IN} = V_{IH} \text{ or } V_{IL}$	$I_{OH} = -12\text{mA MIL.}$	2.4	3.3	—	V
			$I_{OH} = -15\text{mA COM'L.}$	—	—	—	—
V_{OL}	Output LOW Voltage	$V_{CC} = \text{Min.}$ $V_{IN} = V_{IH} \text{ or } V_{IL}$	$I_{OL} = 12\text{mA}$	—	0.3	0.50	V

NOTES:

- For conditions shown as Max. or Min., use appropriate value specified under Electrical Characteristics for the applicable device type.
- Typical values are at $V_{CC} = 5.0\text{V}, +25^\circ\text{C}$ ambient.
- Not more than one output should be shorted at one time. Duration of the short circuit test should not exceed one second.
- The test limit for this parameter is $\pm 5\mu\text{A}$ at $T_A = -55^\circ\text{C}$.
- This parameter is guaranteed but not tested.

2629tbl08

POWER SUPPLY CHARACTERISTICS

Symbol	Parameter	Test Conditions ⁽¹⁾		Min.	Typ. ⁽²⁾	Max.	Unit	
ΔI_{CC}	Quiescent Power Supply Current TTL Inputs HIGH	$V_{CC} = \text{Max.}$ $V_{IN} = 3.4V^{(3)}$		—	0.5	2.0	mA	
I_{CCD}	Dynamic Power Supply Current ⁽⁴⁾	$V_{CC} = \text{Max.}$ Outputs Open $\overline{OE}A$ or $\overline{OE}B = \text{GND}$ One Input Toggling 50% Duty Cycle	$V_{IN} = V_{CC}$ $V_{IN} = \text{GND}$	FCTxxxT	—	0.15	0.25	mA/ MHz
				FCT2xxxT	—	0.06	0.12	
I_C	Total Power Supply Current ⁽⁶⁾	$V_{CC} = \text{Max.}$ Outputs Open $f_{CP} = 10\text{MHz}$ 50% Duty Cycle $\overline{OE}A$ or $\overline{OE}B = \text{GND}$ One Bit Toggling at $f_i = 5\text{MHz}$ 50% Duty Cycle	$V_{IN} = V_{CC}$ $V_{IN} = \text{GND}$	FCTxxxT	—	1.5	3.5	mA
				FCT2xxxT	—	0.6	2.2	
		$V_{IN} = 3.4V$	FCTxxxT	—	2.0	5.5		
		$V_{IN} = \text{GND}$	FCT2xxxT		1.1	4.2		
		$V_{IN} = V_{CC}$ $V_{IN} = \text{GND}$	FCTxxxT	—	3.8	7.3 ⁽⁵⁾		
			FCT2xxxT	—	1.5	4.0 ⁽⁵⁾		
	$V_{IN} = 3.4V$	FCTxxxT	—	6.0	16.3 ⁽⁵⁾			
	$V_{IN} = \text{GND}$	FCT2xxxT	—	3.8	13.0 ⁽⁵⁾			

NOTES:

- For conditions shown as Max. or Min., use appropriate value specified under Electrical Characteristics for the applicable device type.
- Typical values are at $V_{CC} = 5.0V$, $+25^\circ\text{C}$ ambient.
- Per TTL driven input ($V_{IN} = 3.4V$). All other inputs at V_{CC} or GND .
- This parameter is not directly testable, but is derived for use in Total Power Supply Calculations.
- Values for these conditions are examples of the I_{CC} formula. These limits are guaranteed but not tested.
- $I_C = I_{QUIESCENT} + I_{INPUTS} + I_{DYNAMIC}$
 $I_C = I_{CC} + \Delta I_{CC} D_{HNT} + I_{CCD} (f_{CP}/2 + f_i N_i)$
 $I_{CC} = \text{Quiescent Current}$
 $\Delta I_{CC} = \text{Power Supply Current for a TTL High Input } (V_{IN} = 3.4V)$
 $D_H = \text{Duty Cycle for TTL Inputs High}$
 $N_T = \text{Number of TTL Inputs at } D_H$
 $I_{CCD} = \text{Dynamic Current Caused by an Input Transition Pair (HLH or LHL)}$
 $f_{CP} = \text{Clock Frequency for Register Devices (Zero for Non-Register Devices)}$
 $f_i = \text{Input Frequency}$
 $N_i = \text{Number of Inputs at } f_i$
 All currents are in milliamps and all frequencies are in megahertz.

2629tbl09

SWITCHING CHARACTERISTICS OVER OPERATING RANGE

Symbol	Parameter	Condition ⁽¹⁾	29FCT52AT/53AT 29FCT2052AT				29FCT52BT/53BT 29FCT2052BT				Unit
			Com'l.		Mil.		Com'l.		Mil.		
			Min. ⁽²⁾	Max.	Min. ⁽²⁾	Max.	Min. ⁽²⁾	Max.	Min. ⁽²⁾	Max.	
tPLH tPHL	Propagation Delay CPA, CPB to An, Bn	CL = 50pF RL = 500Ω	2.0	10.0	2.0	11.0	2.0	7.5	2.0	8.0	ns
tPZH tPZL	Output Enable Time OEA or OEB to An, Bn		1.5	10.5	1.5	13.0	1.5	8.0	1.5	8.5	ns
tPHZ tPLZ	Output Disable Time OEA or OEB to An, Bn		1.5	10.0	1.5	10.0	1.5	7.5	1.5	8.0	ns
tsu	Set-up Time, HIGH or LOW An, Bn to CPA, CPB		2.5	—	2.5	—	2.5	—	2.5	—	ns
th	Hold Time, HIGH or LOW An, Bn to CPA, CPB		2.0	—	2.0	—	1.5	—	1.5	—	ns
tsu	Set-up Time, HIGH or LOW CEA, CEB to CPA, CPB		3.0	—	3.0	—	3.0	—	3.0	—	ns
th	Hold Time, HIGH or LOW CEA, CEB to CPA, CPB		2.0	—	2.0	—	2.0	—	2.0	—	ns
tw	Clock Pulse Width HIGH or LOW ⁽³⁾		3.0	—	3.0	—	3.0	—	3.0	—	ns

2629 tbl 10

Symbol	Parameter	Condition ⁽¹⁾	29FCT52CT/53CT 29FCT2052CT				29FCT52DT				Unit
			Com'l.		Mil.		Com'l.		Mil.		
			Min. ⁽²⁾	Max.	Min. ⁽²⁾	Max.	Min. ⁽²⁾	Max.	Min. ⁽²⁾	Max.	
tPLH tPHL	Propagation Delay CPA, CPB to An, Bn	CL = 50pF RL = 500Ω	2.0	6.3	2.0	7.3	2.0	4.5	—	—	ns
tPZH tPZL	Output Enable Time OEA or OEB to An, Bn		1.5	7.0	1.5	8.0	1.5	5.6	—	—	ns
tPHZ tPLZ	Output Disable Time OEA or OEB to An, Bn		1.5	6.5	1.5	7.5	1.5	4.3	—	—	ns
tsu	Set-up Time, HIGH or LOW An, Bn to CPA, CPB		2.5	—	2.5	—	1.5	—	—	—	ns
th	Hold Time, HIGH or LOW An, Bn to CPA, CPB		1.5	—	1.5	—	1.0	—	—	—	ns
tsu	Set-up Time, HIGH or LOW CEA, CEB to CPA, CPB		3.0	—	3.0	—	2.0	—	—	—	ns
th	Hold Time, HIGH or LOW CEA, CEB to CPA, CPB		2.0	—	2.0	—	1.0	—	—	—	ns
tw	Clock Pulse Width HIGH or LOW ⁽³⁾		3.0	—	3.0	—	3.0	—	—	—	ns

NOTES:

1. See test circuit and waveforms.
2. Minimum limits are guaranteed but not tested on Propagation Delays.
3. This parameter is guaranteed but not tested.

2629 tbl 11

TEST CIRCUITS AND WAVEFORMS

TEST CIRCUITS FOR ALL OUTPUTS



2629 drw 03

SWITCH POSITION

Test	Switch
Open Drain Disable Low Enable Low	Closed
All Other Tests	Open

DEFINITIONS:

CL= Load capacitance: includes jig and probe capacitance.

RT= Termination resistance: should be equal to ZOUT of the Pulse Generator.

2629 Ink 12

SET-UP, HOLD AND RELEASE TIMES



2629 drw 04

PULSE WIDTH



2629 drw 05

PROPAGATION DELAY



2629 drw 06

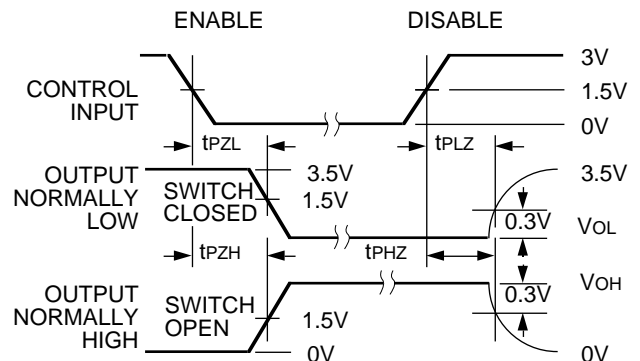

2629 drw 07

NOTES:

1. Diagram shown for input Control Enable-LOW and input Control Disable-HIGH
2. Pulse Generator for All Pulses: Rate $\leq 1.0\text{MHz}$; $t_f \leq 2.5\text{ns}$; $t_r \leq 2.5\text{ns}$

ORDERING INFORMATION



2629 drw 08

