

# DATA SHEET

EEPW 电子产品世界  
.com.cn

## 74LVU04 Hex inverter

Product specification  
Supersedes data of 1997 Feb 12  
IC24 Data Handbook

1998 Apr 20

## Hex inverter

## 74LVU04

## FEATURES

- Wide operating voltage: 1.0 to 5.5 V
- Optimized for Low Voltage applications: 1.0 to 3.6 V
- Accepts TTL input levels between  $V_{CC} = 2.7$  V and  $V_{CC} = 3.6$  V
- Typical  $V_{OLP}$  (output ground bounce)  $< 0.8$  V at  $V_{CC} = 3.3$  V,  $T_{amb} = 25^{\circ}\text{C}$ .
- Typical  $V_{OHV}$  (output  $V_{OH}$  undershoot)  $> 2$  V at  $V_{CC} = 3.3$  V,  $T_{amb} = 25^{\circ}\text{C}$ .
- Output capability: standard
- $I_{CC}$  category: SSI

## DESCRIPTION

The 74LVU04 is a low-voltage, Si-gate CMOS device and is pin compatible with the 74HCU04.

The 74LVU04 is a general purpose hex inverter. Each of the six inverters is a single stage with unbuffered outputs.

## QUICK REFERENCE DATA

GND = 0 V;  $T_{amb} = 25^{\circ}\text{C}$ ;  $t_r = t_f \leq 2.5$  ns

SYMBOL	PARAMETER	CONDITIONS	TYPICAL	UNIT
$t_{PHL}/t_{PLH}$	Propagation delay nA to nY	$C_L = 15$ pF; $V_{CC} = 3.3$ V	6	ns
$C_I$	Input capacitance		3.5	pF
$C_{PD}$	Power dissipation capacitance per gate	Notes 1, 2	18	pF

## NOTES:

- $C_{PD}$  is used to determine the dynamic power dissipation ( $P_D$  in  $\mu\text{W}$ )  
 $P_D = C_{PD} \times V_{CC}^2 \times f_i + \sum (C_L \times V_{CC}^2 \times f_o)$  where:  
 $f_i$  = input frequency in MHz;  $C_L$  = output load capacitance in pF;  
 $f_o$  = output frequency in MHz;  $V_{CC}$  = supply voltage in V;  
 $\sum (C_L \times V_{CC}^2 \times f_o)$  = sum of the outputs.
- The condition is  $V_I = \text{GND to } V_{CC}$ .

## ORDERING INFORMATION

PACKAGES	TEMPERATURE RANGE	OUTSIDE NORTH AMERICA	NORTH AMERICA	PKG. DWG. #
14-Pin Plastic DIL	$-40^{\circ}\text{C to } +125^{\circ}\text{C}$	74LVU04 N	74LVU04 N	SOT27-1
14-Pin Plastic SO	$-40^{\circ}\text{C to } +125^{\circ}\text{C}$	74LVU04 D	74LVU04 D	SOT108-1
14-Pin Plastic SSOP Type II	$-40^{\circ}\text{C to } +125^{\circ}\text{C}$	74LVU04 DB	74LVU04 DB	SOT337-1
14-Pin Plastic TSSOP Type I	$-40^{\circ}\text{C to } +125^{\circ}\text{C}$	74LVU04 PW	74LVU04PW DH	SOT402-1

## PIN DESCRIPTION

PIN NUMBER	SYMBOL	NAME AND FUNCTION
1, 3, 5, 9, 11, 13	1A – 6A	Data inputs
2, 4, 6, 8, 10, 12	1Y – 6Y	Data outputs
7	GND	Ground (0 V)
14	$V_{CC}$	Positive supply voltage

## FUNCTION TABLE

INPUTS	OUTPUTS
nA	nY
L	H
H	L

## NOTES:

H = HIGH voltage level  
L = LOW voltage level

# Hex inverter

# 74LVU04

### PIN CONFIGURATION

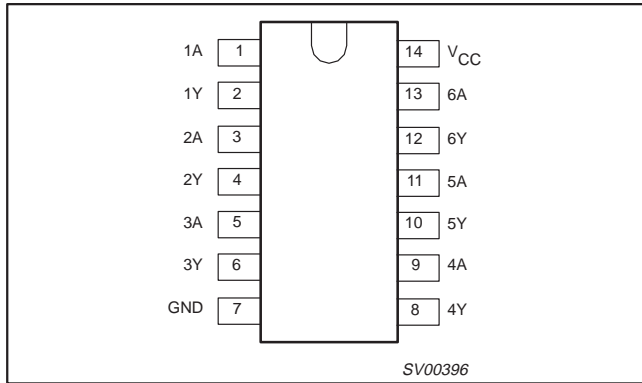

### LOGIC SYMBOL

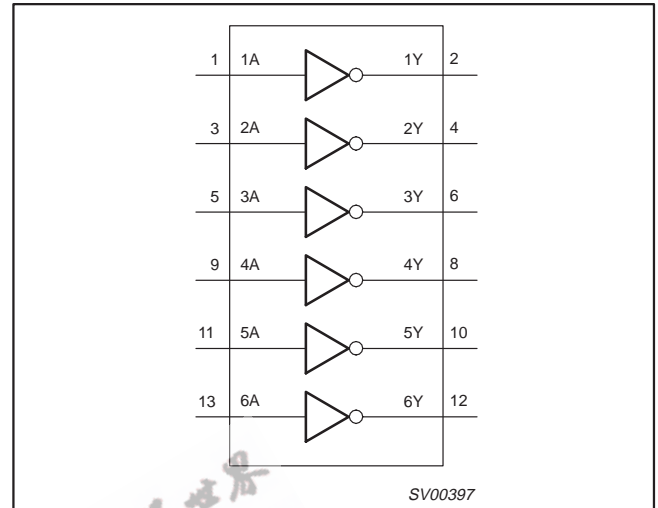

### LOGIC SYMBOL (IEEE/IEC)

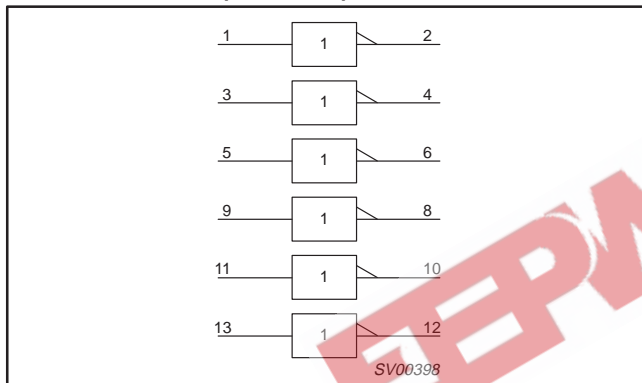

### SCHEMATIC DIAGRAM (ONE INVERTER)

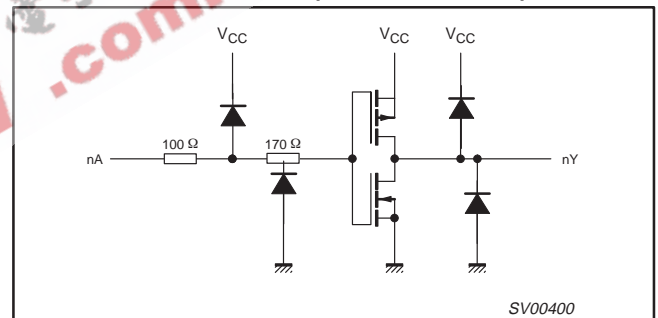

### RECOMMENDED OPERATING CONDITIONS

SYMBOL	PARAMETER	CONDITIONS	MIN	TYP.	MAX	UNIT
$V_{CC}$	DC supply voltage	See Note 1	1.0	3.3	5.5	V
$V_I$	Input voltage		0	–	$V_{CC}$	V
$V_O$	Output voltage		0	–	$V_{CC}$	V
$T_{amb}$	Operating ambient temperature range in free air	See DC and AC characteristics	–40 –40		+85 +125	°C
$t_r, t_f$	Input rise and fall times	$V_{CC} = 1.0V$ to $2.0V$ $V_{CC} = 2.0V$ to $2.7V$ $V_{CC} = 2.7V$ to $3.6V$ $V_{CC} = 3.6V$ to $5.5V$	– – – –	– – – –	500 200 100 50	ns/V

**NOTE:**

1. The LV is guaranteed to function down to  $V_{CC} = 1.0V$  (input levels GND or  $V_{CC}$ ); DC characteristics are guaranteed from  $V_{CC} = 1.2V$  to  $V_{CC} = 5.5V$ .

## Hex inverter

74LVU04

**ABSOLUTE MAXIMUM RATINGS<sup>1, 2</sup>**

In accordance with the Absolute Maximum Rating System (IEC 134).

Voltages are referenced to GND (ground = 0V).

SYMBOL	PARAMETER	CONDITIONS	RATING	UNIT
$V_{CC}$	DC supply voltage		-0.5 to +7.0	V
$\pm I_{IK}$	DC input diode current	$V_I < -0.5$ or $V_I > V_{CC} + 0.5V$	20	mA
$\pm I_{OK}$	DC output diode current	$V_O < -0.5$ or $V_O > V_{CC} + 0.5V$	50	mA
$\pm I_O$	DC output source or sink current – standard outputs	$-0.5V < V_O < V_{CC} + 0.5V$	25	mA
$\pm I_{GND}$ , $\pm I_{CC}$	DC $V_{CC}$ or GND current for types with – standard outputs		50	mA
$T_{stg}$	Storage temperature range		-65 to +150	°C
$P_{TOT}$	Power dissipation per package – plastic DIL – plastic mini-pack (SO) – plastic shrink mini-pack (SSOP and TSSOP)	for temperature range: -40 to +125°C above +70°C derate linearly with 12 mW/K above +70°C derate linearly with 8 mW/K above +60°C derate linearly with 5.5 mW/K	750 500 400	mW

**NOTE:**

- Stresses beyond those listed may cause permanent damage to the device. These are stress ratings only and functional operation of the device at these or any other conditions beyond those indicated under "recommended operating conditions" is not implied. Exposure to absolute-maximum-rated conditions for extended periods may affect device reliability.
- The input and output voltage ratings may be exceeded if the input and output current ratings are observed.

**DC ELECTRICAL CHARACTERISTICS**

Over recommended operating conditions. Voltages are referenced to GND (ground = 0V).

SYMBOL	PARAMETER	TEST CONDITIONS	LIMITS					UNIT
			-40°C to +85°C			-40°C to +125°C		
			MIN	TYP <sup>1</sup>	MAX	MIN	MAX	
$V_{IH}$	HIGH level Input voltage	$V_{CC} = 1.2V$	1.0			1.0		V
		$V_{CC} = 2.0V$	1.6			1.6		
		$V_{CC} = 2.7$ to $3.6V$	2.4			2.4		
		$V_{CC} = 4.5$ to $5.5V$	$0.8 * V_{CC}$			$0.8 * V_{CC}$		
$V_{IL}$	LOW level Input voltage	$V_{CC} = 1.2V$			0.2		0.2	V
		$V_{CC} = 2.0V$			0.4		0.4	
		$V_{CC} = 2.7$ to $3.6V$			0.5		0.5	
		$V_{CC} = 4.5$ to $5.5$			$0.2 * V_{CC}$		$0.2 * V_{CC}$	
$V_{OH}$	HIGH level output voltage	$V_{CC} = 1.2V$ ; $V_I = V_{IH}$ or $V_{IL}$ ; $-I_O = 100\mu A$		1.2				V
		$V_{CC} = 2.0V$ ; $V_I = V_{IH}$ or $V_{IL}$ ; $-I_O = 100\mu A$	1.8	2.0		1.8		
		$V_{CC} = 2.7V$ ; $V_I = V_{IH}$ or $V_{IL}$ ; $-I_O = 100\mu A$	2.5	2.7		2.5		
		$V_{CC} = 3.0V$ ; $V_I = V_{IH}$ or $V_{IL}$ ; $-I_O = 100\mu A$	2.8	3.0		2.8		
		$V_{CC} = 4.5V$ ; $V_I = V_{IH}$ or $V_{IL}$ ; $-I_O = 100\mu A$	4.3	4.5		4.3		
$V_{OH}$	HIGH level output voltage	$V_{CC} = 3.0V$ ; $V_I = V_{IH}$ or $V_{IL}$ ; $-I_O = 6mA$	2.40	2.82		2.20		V
		$V_{CC} = 4.5V$ ; $V_I = V_{IH}$ or $V_{IL}$ ; $-I_O = 12mA$	3.60	4.20		3.50		
$V_{OL}$	LOW level output voltage	$V_{CC} = 1.2V$ ; $V_I = V_{IH}$ or $V_{IL}$ ; $I_O = 100\mu A$		0				V
		$V_{CC} = 2.0V$ ; $V_I = V_{IH}$ or $V_{IL}$ ; $I_O = 100\mu A$		0	0.2		0.2	
		$V_{CC} = 2.7V$ ; $V_I = V_{IH}$ or $V_{IL}$ ; $I_O = 100\mu A$		0	0.2		0.2	
		$V_{CC} = 3.0V$ ; $V_I = V_{IH}$ or $V_{IL}$ ; $I_O = 100\mu A$		0	0.2		0.2	
		$V_{CC} = 4.5V$ ; $V_I = V_{IH}$ or $V_{IL}$ ; $I_O = 100\mu A$		0	0.2		0.2	

# Hex inverter

# 74LVU04

## DC ELECTRICAL CHARACTERISTICS (Continued)

SYMBOL	PARAMETER	TEST CONDITIONS	LIMITS					UNIT
			-40°C to +85°C			-40°C to +125°C		
			MIN	TYP <sup>1</sup>	MAX	MIN	MAX	
V <sub>OL</sub>	LOW level output voltage	V <sub>CC</sub> = 3.0V; V <sub>I</sub> = V <sub>IH</sub> or V <sub>IL</sub> ; I <sub>O</sub> = 6mA		0.25	0.40		0.50	V
		V <sub>CC</sub> = 4.5V; V <sub>I</sub> = V <sub>IH</sub> or V <sub>IL</sub> ; I <sub>O</sub> = 12mA		0.35	0.55		0.65	
±I <sub>I</sub>	Input leakage current	V <sub>CC</sub> = 5.5V; V <sub>I</sub> = V <sub>CC</sub> or GND			1.0		1.0	µA
I <sub>CC</sub>	Quiescent supply current	V <sub>CC</sub> = 5.5V; V <sub>I</sub> = V <sub>CC</sub> or GND; I <sub>O</sub> = 0			20.0		40.0	µA
ΔI <sub>CC</sub>	Additional quiescent supply current per input	V <sub>CC</sub> = 2.7V to 3.6V; V <sub>I</sub> = V <sub>CC</sub> - 0.6V			500		850	µA

**NOTE:**

1. All typical values are measured at T<sub>amb</sub> = 25°C.

## AC CHARACTERISTICS

GND = 0V; t<sub>r</sub> = t<sub>f</sub> = 2.5ns; C<sub>L</sub> = 50pF; R<sub>L</sub> = 500Ω

SYMBOL	PARAMETER	WAVEFORM	CONDITION	LIMITS					UNIT
				-40 to +85 °C			-40 to +125 °C		
				MIN	TYP <sup>1</sup>	MAX	MIN	MAX	
t <sub>PHL/PLH</sub>	Propagation delay nA to nY	Figure 1	V <sub>CC</sub> (V)						ns
			1.2		35				
			2.0		12	14		17	
			2.7		9	10		13	
			3.0 to 3.6		7 <sup>2</sup>	8		10	
4.5 to 5.5			7		9				

**NOTES:**

1. Unless otherwise stated, all typical values are measured at T<sub>amb</sub> = 25°C
2. Typical values are measured at V<sub>CC</sub> = 3.3 V.

## AC WAVEFORMS

V<sub>M</sub> = 1.5 V at V<sub>CC</sub> ≥ 2.7 V and ≤ 3.6 V

V<sub>M</sub> = 0.5 × V<sub>CC</sub> at V<sub>CC</sub> < 2.7 V and ≥ 4.5 V

V<sub>OL</sub> and V<sub>OH</sub> are the typical output voltage drop that occur with the output load.

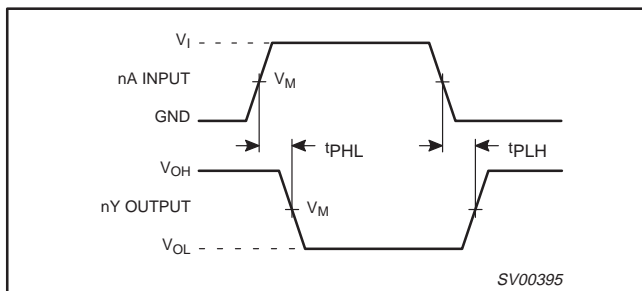

Figure 1. Input (nA) to output (nY) propagation delays and output transition times.

## TYPICAL TRANSFER CHARACTERISTICS

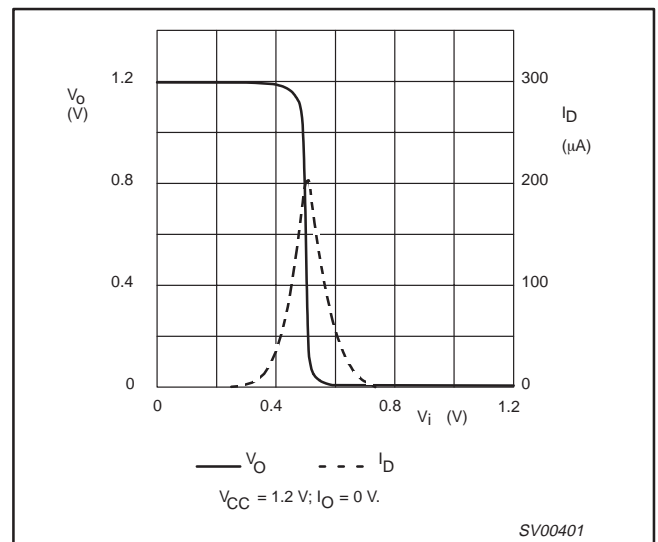

Figure 2.

Hex inverter

74LVU04

TYPICAL TRANSFER CHARACTERISTICS (Continued)

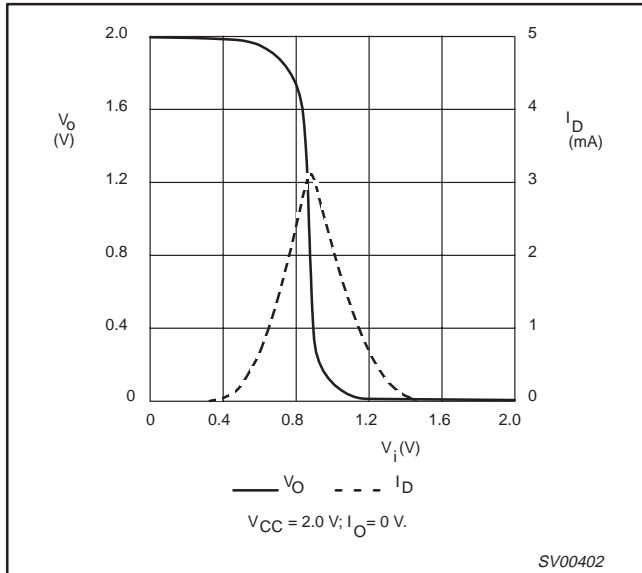

Figure 3.

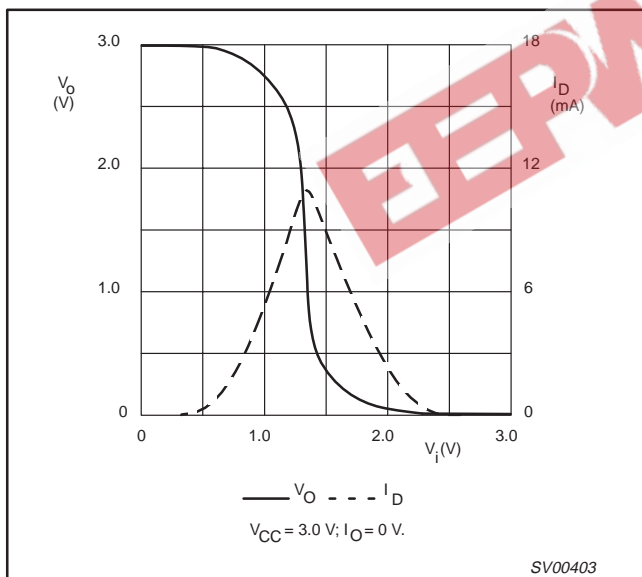

Figure 4.

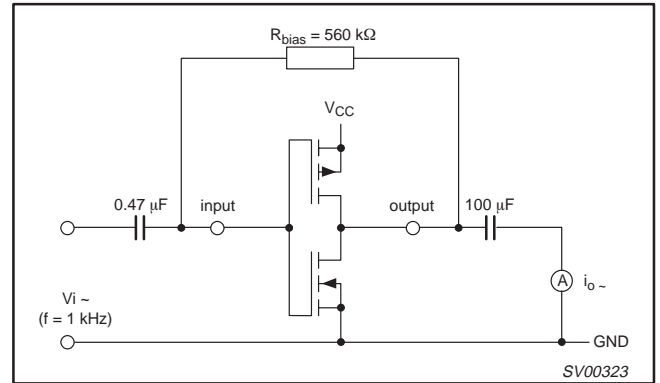

Figure 5. Test set-up for measuring forward transconductance  $g_{fs} = di_o/dv_i$  at  $v_O$  is constant (see also graph Figure 6).

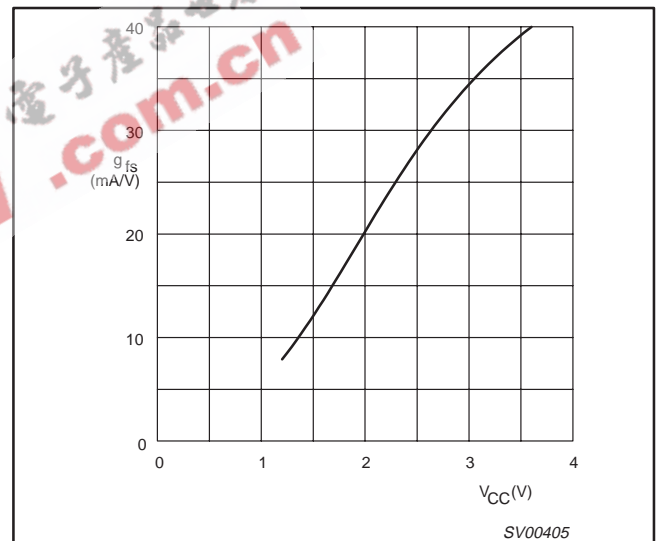

Figure 6. Typical forward transconductance  $g_{fs}$  as a function of the supply voltage  $V_{CC}$  at  $T_{amb} = 25^\circ\text{C}$ .

# Hex inverter

# 74LVU04

## APPLICATION INFORMATION

Some applications for the 74LVU04 are:

- Linear amplifier (see Figure 7)
- In crystal oscillator designs (see Figure 8)
- Astable multivibrator (see Figure 9)

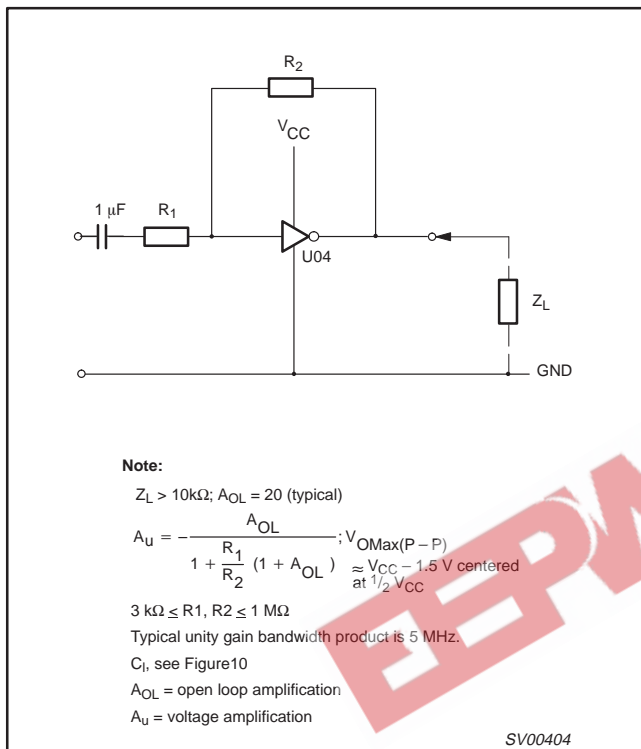

Figure 7. LVU04 used as a linear amplifier.

## EXTERNAL COMPONENTS FOR RESONATOR (f < 1 MHz)

FREQUENCY (kHz)	R <sub>1</sub> (MΩ)	R <sub>2</sub> (KΩ)	C <sub>1</sub> (pF)	C <sub>2</sub> (pF)
10 .. 15.9	2.2	220	56	20
16 .. 24.9	2.2	220	56	10
25 .. 54.9	2.2	100	56	10
55 .. 129.9	2.2	100	47	5
130 .. 199.9	2.2	47	47	5
200 .. 349.9	2.2	47	47	5
350 .. 600	2.2	47	47	5

**WHERE:**

All values given are typical and must be used as an initial set-up.

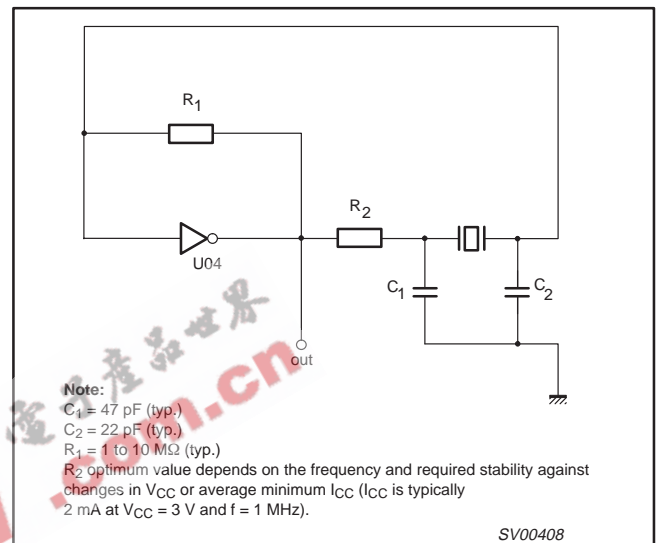

Figure 8. Crystal oscillator configuration.

## OPTIMUM VALUE FOR R<sub>2</sub>

FREQUENCY (MHz)	R <sub>2</sub> (kΩ)	Optimum
3	2.0 8.0	Minimum required $I_{CC}$ Minimum influence due to change in $V_{CC}$
6	1.0 4.7	Minimum $I_{CC}$ Minimum influence by $V_{CC}$
10	0.5 2.0	Minimum $I_{CC}$ Minimum influence by $V_{CC}$
14	0.5 1.0	Minimum $I_{CC}$ Minimum influence by $V_{CC}$
> 14	Replace $R_2$ by $C_3$ with a typical value of 35 pF	

Hex inverter

74LVU04

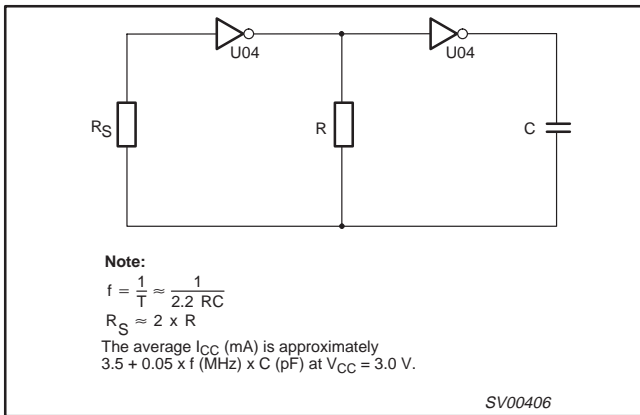

Figure 9. LVU04 used as an astable multivibrator.

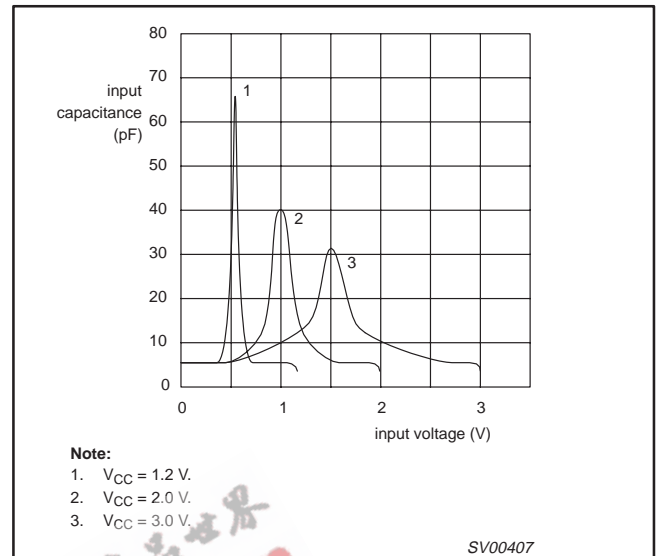

Figure 10. Typical input capacitance as function of input voltage.

**Note for Application Information**

All values given are typical unless otherwise specified.



Hex inverter

74LVU04

DIP14: plastic dual in-line package; 14 leads (300 mil)

SOT27-1

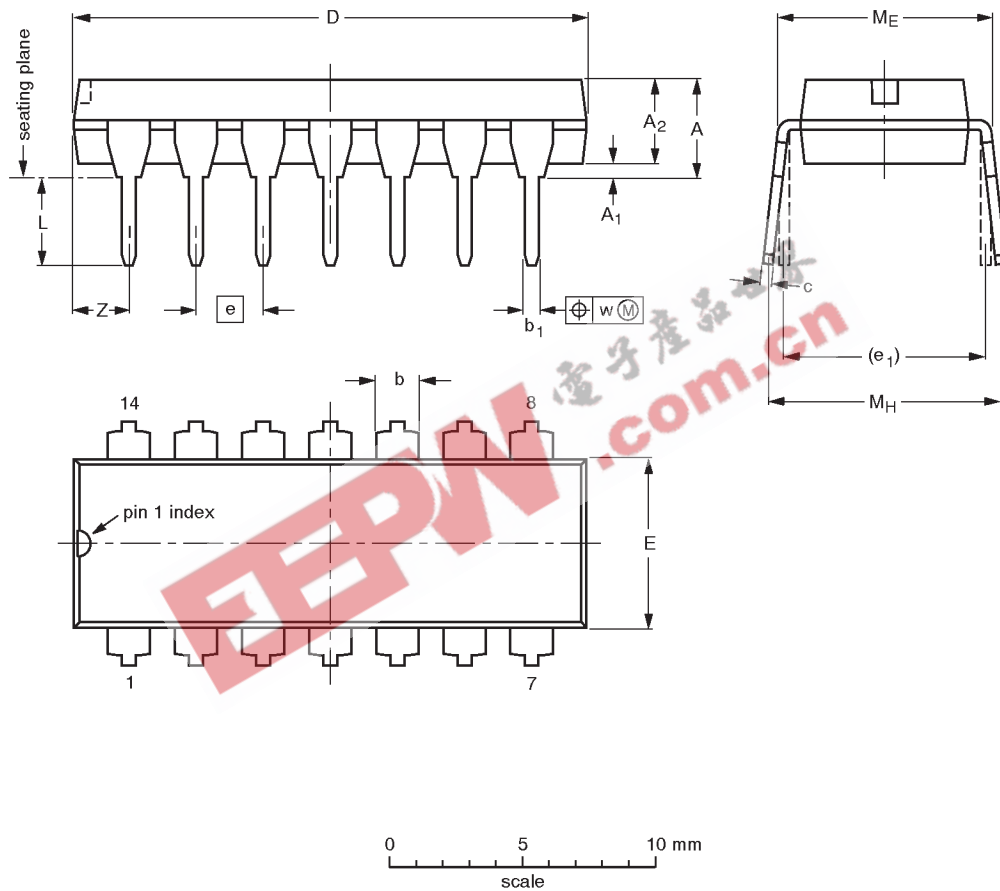

DIMENSIONS (inch dimensions are derived from the original mm dimensions)

UNIT	A max.	A <sub>1</sub> min.	A <sub>2</sub> max.	b	b <sub>1</sub>	c	D <sup>(1)</sup>	E <sup>(1)</sup>	e	e <sub>1</sub>	L	M <sub>E</sub>	M <sub>H</sub>	w	Z <sup>(1)</sup> max.
mm	4.2	0.51	3.2	1.73 1.13	0.53 0.38	0.36 0.23	19.50 18.55	6.48 6.20	2.54	7.62	3.60 3.05	8.25 7.80	10.0 8.3	0.254	2.2
inches	0.17	0.020	0.13	0.068 0.044	0.021 0.015	0.014 0.009	0.77 0.73	0.26 0.24	0.10	0.30	0.14 0.12	0.32 0.31	0.39 0.33	0.01	0.087

Note

1. Plastic or metal protrusions of 0.25 mm maximum per side are not included.

OUTLINE VERSION	REFERENCES				EUROPEAN PROJECTION	ISSUE DATE
	IEC	JEDEC	EIAJ			
SOT27-1	050G04	MO-001AA				92-11-17 95-03-11

Hex inverter

74LVU04

SO14: plastic small outline package; 14 leads; body width 3.9 mm

SOT108-1

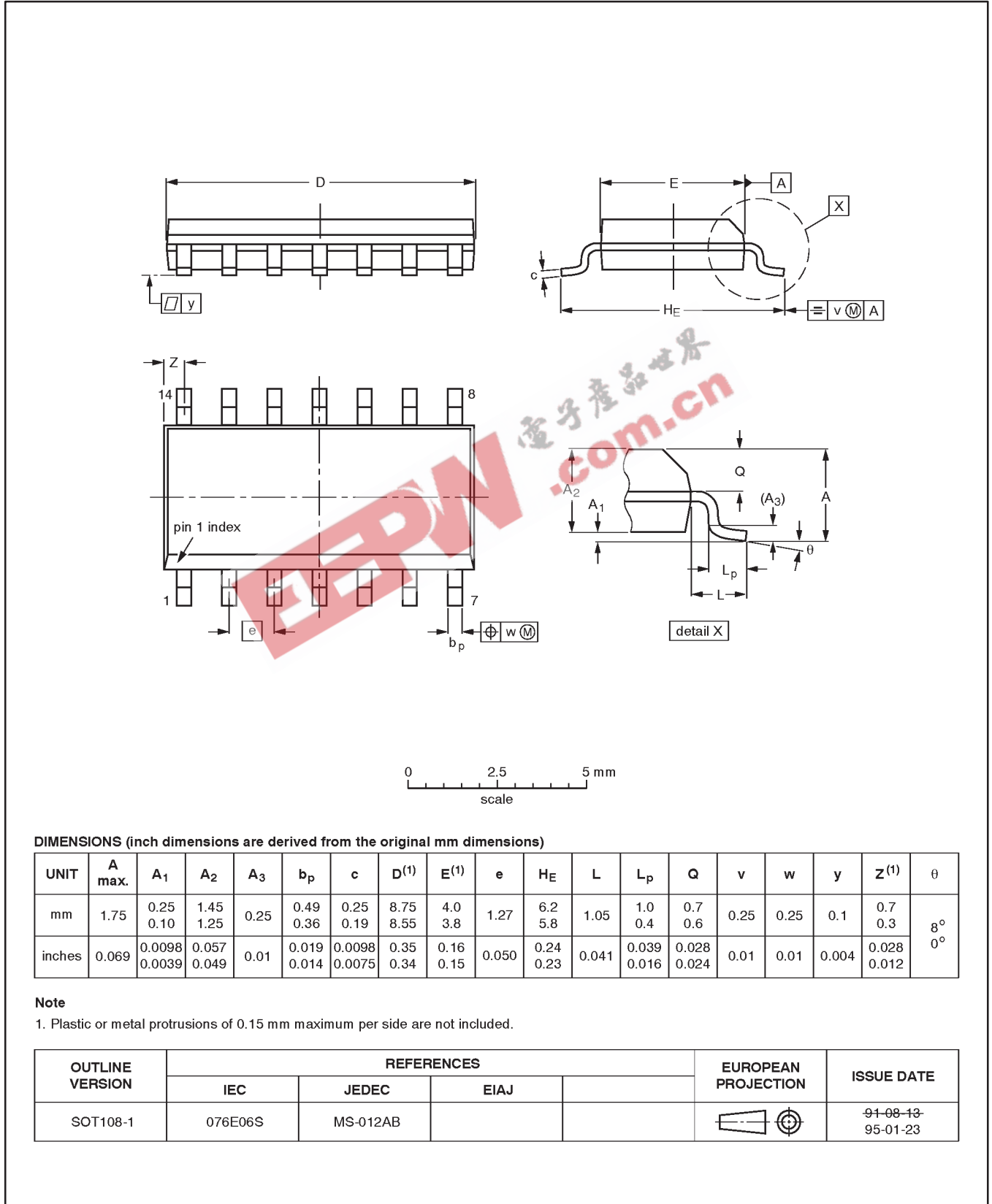

DIMENSIONS (inch dimensions are derived from the original mm dimensions)

UNIT	A max.	A <sub>1</sub>	A <sub>2</sub>	A <sub>3</sub>	b <sub>p</sub>	c	D <sup>(1)</sup>	E <sup>(1)</sup>	e	H <sub>E</sub>	L	L <sub>p</sub>	Q	v	w	y	z <sup>(1)</sup>	θ
mm	1.75	0.25 0.10	1.45 1.25	0.25	0.49 0.36	0.25 0.19	8.75 8.55	4.0 3.8	1.27	6.2 5.8	1.05	1.0 0.4	0.7 0.6	0.25	0.25	0.1	0.7 0.3	8° 0°
inches	0.069	0.0098 0.0039	0.057 0.049	0.01	0.019 0.014	0.0098 0.0075	0.35 0.34	0.16 0.15	0.050	0.24 0.23	0.041	0.039 0.016	0.028 0.024	0.01	0.01	0.004	0.028 0.012	

Note

1. Plastic or metal protrusions of 0.15 mm maximum per side are not included.

OUTLINE VERSION	REFERENCES				EUROPEAN PROJECTION	ISSUE DATE
	IEC	JEDEC	EIAJ			
SOT108-1	076E06S	MS-012AB				91-08-13 95-01-23

Hex inverter

74LVU04

SSOP14: plastic shrink small outline package; 14 leads; body width 5.3 mm

SOT337-1

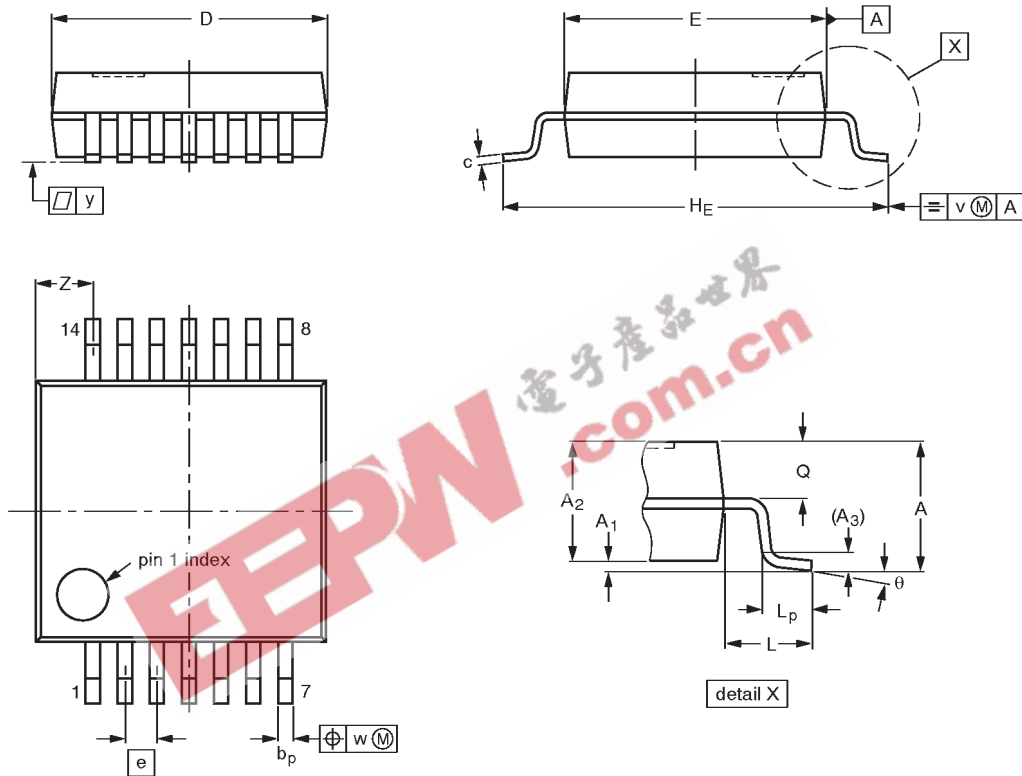

**DIMENSIONS** (mm are the original dimensions)

UNIT	A max.	A <sub>1</sub>	A <sub>2</sub>	A <sub>3</sub>	b <sub>p</sub>	c	D <sup>(1)</sup>	E <sup>(1)</sup>	e	H <sub>E</sub>	L	L <sub>p</sub>	Q	v	w	y	Z <sup>(1)</sup>	θ
mm	2.0	0.21 0.05	1.80 1.65	0.25	0.38 0.25	0.20 0.09	6.4 6.0	5.4 5.2	0.65	7.9 7.6	1.25	1.03 0.63	0.9 0.7	0.2	0.13	0.1	1.4 0.9	8° 0°

**Note**

1. Plastic or metal protrusions of 0.25 mm maximum per side are not included.

OUTLINE VERSION	REFERENCES				EUROPEAN PROJECTION	ISSUE DATE
	IEC	JEDEC	EIAJ			
SOT337-1		MO-150AB				<del>95-02-04</del> 96-01-18

Hex inverter

74LVU04

TSSOP14: plastic thin shrink small outline package; 14 leads; body width 4.4 mm

SOT402-1

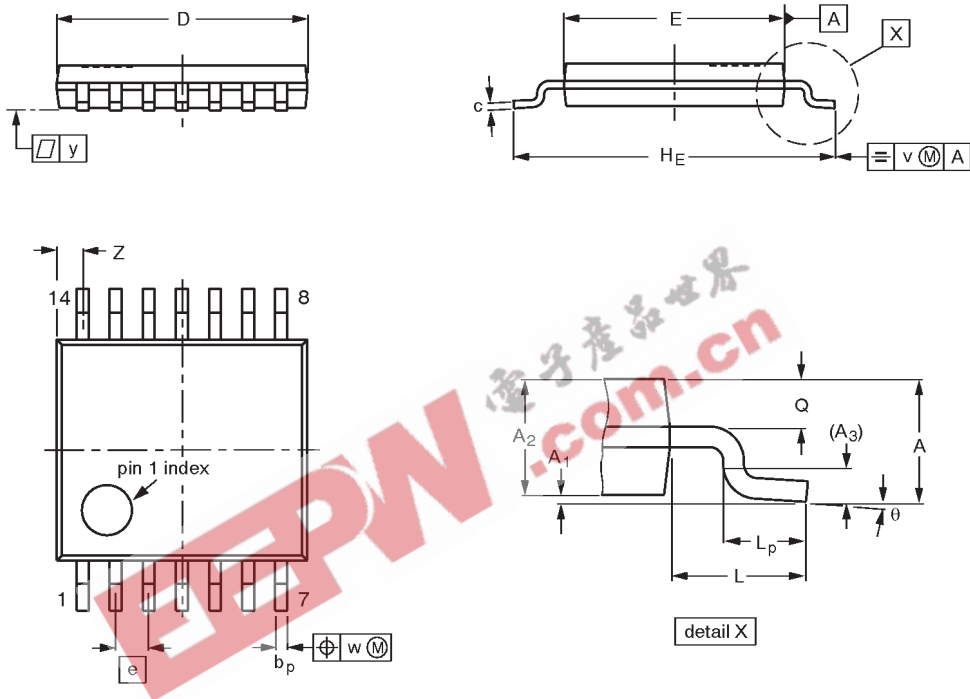

**DIMENSIONS (mm are the original dimensions)**

UNIT	A max.	A <sub>1</sub>	A <sub>2</sub>	A <sub>3</sub>	b <sub>p</sub>	c	D <sup>(1)</sup>	E <sup>(2)</sup>	e	H <sub>E</sub>	L	L <sub>p</sub>	Q	v	w	y	Z <sup>(1)</sup>	θ
mm	1.10	0.15 0.05	0.95 0.80	0.25	0.30 0.19	0.2 0.1	5.1 4.9	4.5 4.3	0.65	6.6 6.2	1.0	0.75 0.50	0.4 0.3	0.2	0.13	0.1	0.72 0.38	8° 0°

**Notes**

1. Plastic or metal protrusions of 0.15 mm maximum per side are not included.
2. Plastic interlead protrusions of 0.25 mm maximum per side are not included.

OUTLINE VERSION	REFERENCES				EUROPEAN PROJECTION	ISSUE DATE
	IEC	JEDEC	EIAJ			
SOT402-1		MO-153				-94-07-12- 95-04-04

---

Hex inverter

74LVU04

---

NOTES



## Hex inverter

74LVU04

## DEFINITIONS

Data Sheet Identification	Product Status	Definition
<i>Objective Specification</i>	<b>Formative or in Design</b>	This data sheet contains the design target or goal specifications for product development. Specifications may change in any manner without notice.
<i>Preliminary Specification</i>	<b>Preproduction Product</b>	This data sheet contains preliminary data, and supplementary data will be published at a later date. Philips Semiconductors reserves the right to make changes at any time without notice in order to improve design and supply the best possible product.
<i>Product Specification</i>	<b>Full Production</b>	This data sheet contains Final Specifications. Philips Semiconductors reserves the right to make changes at any time without notice, in order to improve design and supply the best possible product.

Philips Semiconductors and Philips Electronics North America Corporation reserve the right to make changes, without notice, in the products, including circuits, standard cells, and/or software, described or contained herein in order to improve design and/or performance. Philips Semiconductors assumes no responsibility or liability for the use of any of these products, conveys no license or title under any patent, copyright, or mask work right to these products, and makes no representations or warranties that these products are free from patent, copyright, or mask work right infringement, unless otherwise specified. Applications that are described herein for any of these products are for illustrative purposes only. Philips Semiconductors makes no representation or warranty that such applications will be suitable for the specified use without further testing or modification.

## LIFE SUPPORT APPLICATIONS

Philips Semiconductors and Philips Electronics North America Corporation Products are not designed for use in life support appliances, devices, or systems where malfunction of a Philips Semiconductors and Philips Electronics North America Corporation Product can reasonably be expected to result in a personal injury. Philips Semiconductors and Philips Electronics North America Corporation customers using or selling Philips Semiconductors and Philips Electronics North America Corporation Products for use in such applications do so at their own risk and agree to fully indemnify Philips Semiconductors and Philips Electronics North America Corporation for any damages resulting from such improper use or sale.

**Philips Semiconductors**  
 811 East Arques Avenue  
 P.O. Box 3409  
 Sunnyvale, California 94088-3409  
 Telephone 800-234-7381

© Copyright Philips Electronics North America Corporation 1998  
 All rights reserved. Printed in U.S.A.

print code

Date of release: 05-96

Document order number:

9397-750-04405

*Let's make things better.*