

DATA SHEET

For a complete data sheet, please also download:

- The IC06 74HC/HCT/HCU/HCMOS Logic Family Specifications
- The IC06 74HC/HCT/HCU/HCMOS Logic Package Information
- The IC06 74HC/HCT/HCU/HCMOS Logic Package Outlines

EEPW 电子产品世界
.com.cn

74HC/HCT4051 8-channel analog multiplexer/demultiplexer

Product specification
File under Integrated Circuits, IC06

December 1990

8-channel analog multiplexer/demultiplexer

74HC/HCT4051

FEATURES

- Wide analog input voltage range: ± 5 V.
- Low "ON" resistance:
80 Ω (typ.) at $V_{CC} - V_{EE} = 4.5$ V
70 Ω (typ.) at $V_{CC} - V_{EE} = 6.0$ V
60 Ω (typ.) at $V_{CC} - V_{EE} = 9.0$ V
- Logic level translation:
to enable 5 V logic to communicate with ± 5 V analog signals
- Typical "break before make" built in
- Output capability: non-standard
- I_{CC} category: MSI

GENERAL DESCRIPTION

The 74HC/HCT4051 are high-speed Si-gate CMOS devices and are pin compatible with the "4051" of the

"4000B" series. They are specified in compliance with JEDEC standard no. 7A.

The 74HC/HCT4051 are 8-channel analog multiplexers/demultiplexers with three digital select inputs (S_0 to S_2), an active LOW enable input (\bar{E}), eight independent inputs/outputs (Y_0 to Y_7) and a common input/output (Z).

With \bar{E} LOW, one of the eight switches is selected (low impedance ON-state) by S_0 to S_2 . With \bar{E} HIGH, all switches are in the high impedance OFF-state, independent of S_0 to S_2 .

V_{CC} and GND are the supply voltage pins for the digital control inputs (S_0 to S_2 , and \bar{E}). The V_{CC} to GND ranges are 2.0 to 10.0 V for HC and 4.5 to 5.5 V for HCT. The analog inputs/outputs (Y_0 to Y_7 , and Z) can swing between V_{CC} as a positive limit and V_{EE} as a negative limit. $V_{CC} - V_{EE}$ may not exceed 10.0 V.

For operation as a digital multiplexer/demultiplexer, V_{EE} is connected to GND (typically ground).

QUICK REFERENCE DATA

$V_{EE} = \text{GND} = 0$ V; $T_{\text{amb}} = 25$ °C; $t_r = t_f = 6$ ns

SYMBOL	PARAMETER	CONDITIONS	TYPICAL		UNIT
			HC	HCT	
t_{PZH}/t_{PZL}	turn "ON" time \bar{E} to V_{OS} S_n to V_{OS}	$C_L = 15$ pF; $R_L = 1$ k Ω ; $V_{CC} = 5$ V	22	22	ns
			20	24	ns
t_{PHZ}/t_{PLZ}	turn "OFF" time \bar{E} to V_{OS} S_n to V_{OS}		18	16	ns
			19	20	ns
C_I	input capacitance		3.5	3.5	pF
C_{PD}	power dissipation capacitance per switch	notes 1 and 2	25	25	pF
C_S	max. switch capacitance independent (Y) common (Z)		5	5	pF
			25	25	pF

Notes

1. C_{PD} is used to determine the dynamic power dissipation (P_D in μ W):

$$P_D = C_{PD} \times V_{CC}^2 \times f_i + \sum \{ (C_L + C_S) \times V_{CC}^2 \times f_o \} \text{ where:}$$

f_i = input frequency in MHz

f_o = output frequency in MHz

$\sum \{ (C_L + C_S) \times V_{CC}^2 \times f_o \}$ = sum of outputs

C_L = output load capacitance in pF

C_S = max. switch capacitance in pF

V_{CC} = supply voltage in V

2. For HC the condition is $V_I = \text{GND}$ to V_{CC}
For HCT the condition is $V_I = \text{GND}$ to $V_{CC} - 1.5$ V

8-channel analog multiplexer/demultiplexer

74HC/HCT4051

ORDERING INFORMATION

See "74HC/HCT/HCU/HCMOS Logic Package Information".

PIN DESCRIPTION

PIN NO.	SYMBOL	NAME AND FUNCTION
3	Z	common input/output
6	\bar{E}	enable input (active LOW)
7	V_{EE}	negative supply voltage
8	GND	ground (0 V)
11, 10, 9	S_0 to S_2	select inputs
13, 14, 15, 12, 1, 5, 2, 4	Y_0 to Y_7	independent inputs/outputs
16	V_{CC}	positive supply voltage

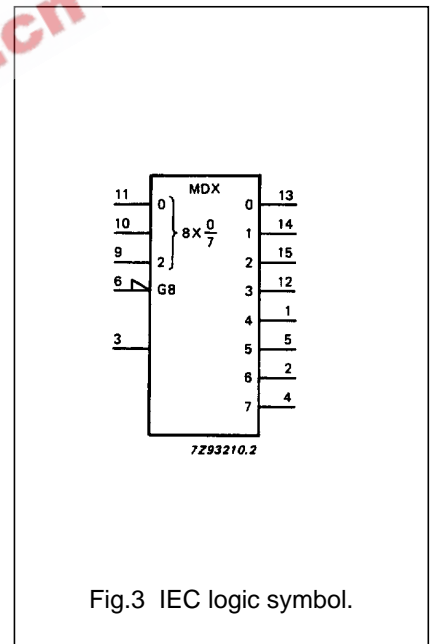
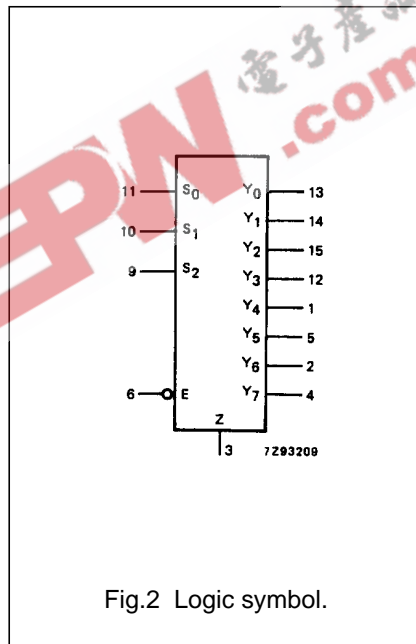
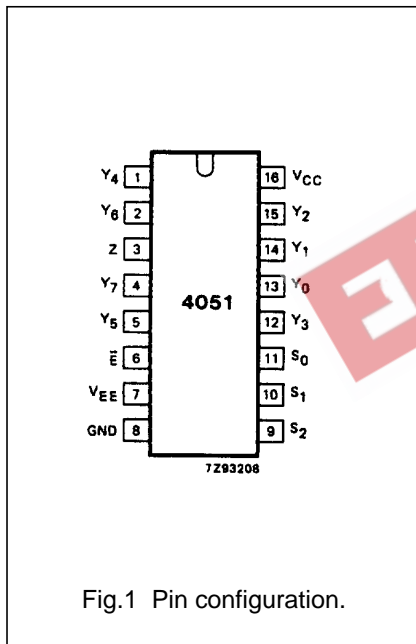

8-channel analog multiplexer/demultiplexer

74HC/HCT4051

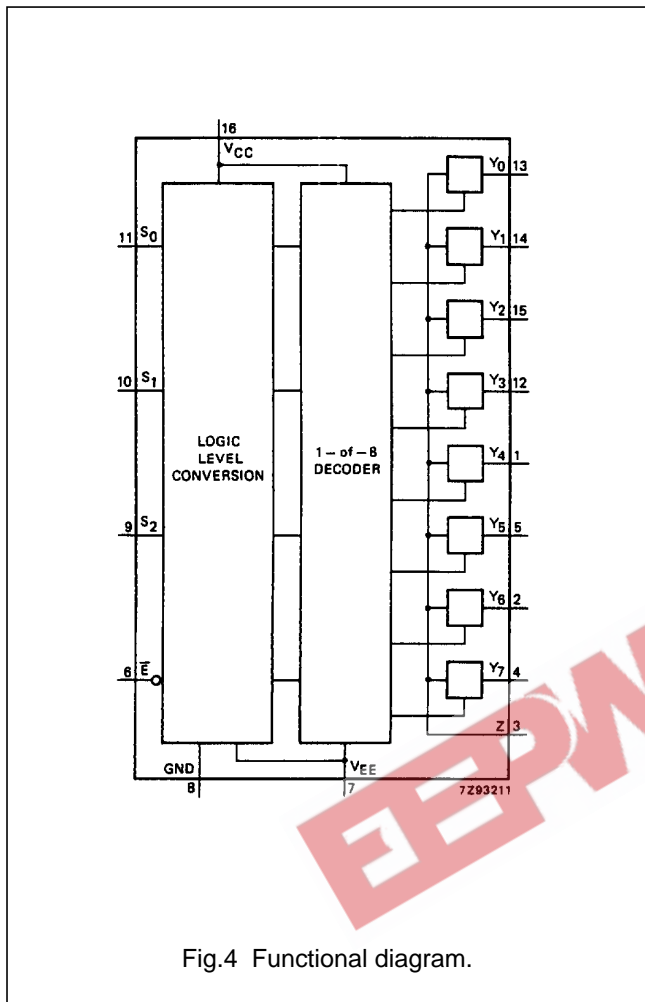

Fig.4 Functional diagram.

APPLICATIONS

- Analog multiplexing and demultiplexing
- Digital multiplexing and demultiplexing
- Signal gating

FUNCTION TABLE

INPUTS				channel ON
E-bar	S ₂	S ₁	S ₀	
L	L	L	L	Y ₀ - Z
L	L	L	H	Y ₁ - Z
L	L	H	L	Y ₂ - Z
L	L	H	H	Y ₃ - Z
L	H	L	L	Y ₄ - Z
L	H	L	H	Y ₅ - Z
L	H	H	L	Y ₆ - Z
L	H	H	H	Y ₇ - Z
H	X	X	X	none

Notes

1. H = HIGH voltage level
L = LOW voltage level
X = don't care

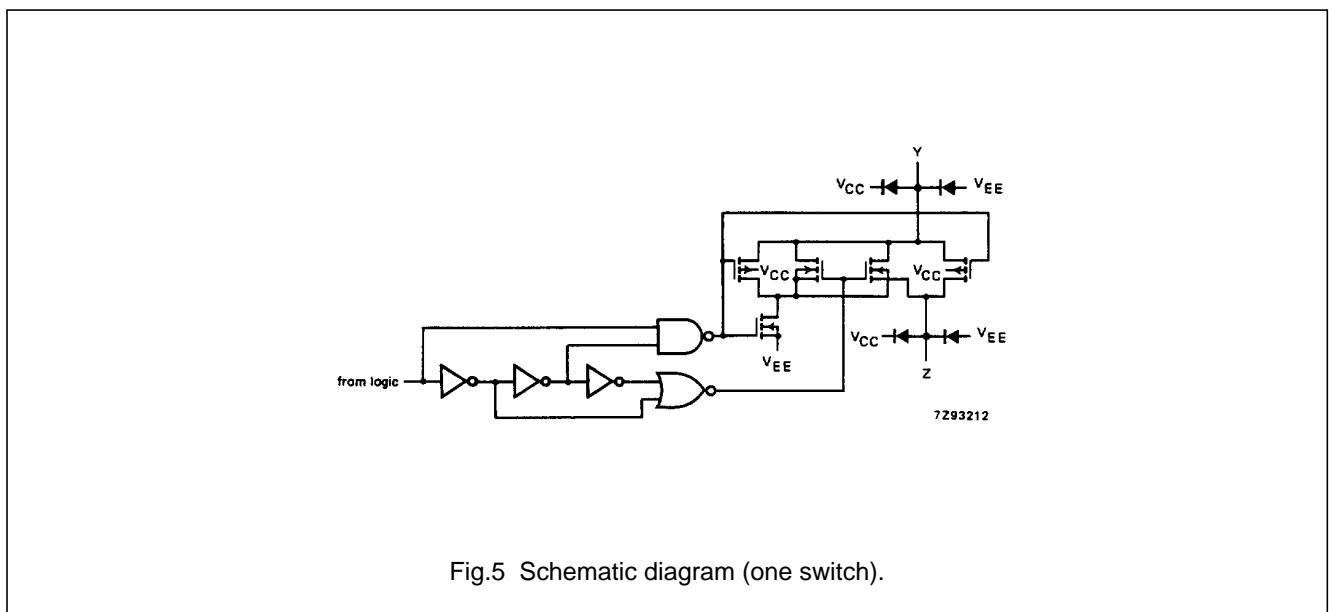

Fig.5 Schematic diagram (one switch).

8-channel analog multiplexer/demultiplexer

74HC/HCT4051

RATINGS

Limiting values in accordance with the Absolute Maximum System (IEC 134)

Voltages are referenced to $V_{EE} = \text{GND}$ (ground = 0 V)

SYMBOL	PARAMETER	MIN.	MAX.	UNIT	CONDITIONS
V_{CC}	DC supply voltage	-0.5	+11.0	V	
$\pm I_{IK}$	DC digital input diode current		20	mA	for $V_I < -0.5 \text{ V}$ or $V_I > V_{CC} + 0.5 \text{ V}$
$\pm I_{SK}$	DC switch diode current		20	mA	for $V_S < -0.5 \text{ V}$ or $V_S > V_{CC} + 0.5 \text{ V}$
$\pm I_S$	DC switch current		25	mA	for $-0.5 \text{ V} < V_S < V_{CC} + 0.5 \text{ V}$
$\pm I_{EE}$	DC V_{EE} current		20	mA	
$\pm I_{CC}; \pm I_{GND}$	DC V_{CC} or GND current		50	mA	
T_{stg}	storage temperature range	-65	+150	°C	
P_{tot}	power dissipation per package				for temperature range: -40 to +125 °C 74HC/HCT
	plastic DIL		750	mW	above +70 °C: derate linearly with 12 mW/K
	plastic mini-pack (SO)		500	mW	above +70 °C: derate linearly with 8 mW/K
P_S	power dissipation per switch		100	mW	

Note to ratings

- To avoid drawing V_{CC} current out of terminal Z, when switch current flows in terminals Y_n , the voltage drop across the bidirectional switch must not exceed 0.4 V. If the switch current flows into terminal Z, no V_{CC} current will flow out of terminals Y_n . In this case there is no limit for the voltage drop across the switch, but the voltages at Y_n and Z may not exceed V_{CC} or V_{EE} .

RECOMMENDED OPERATING CONDITIONS

SYMBOL	PARAMETER	74HC			74HCT			UNIT	CONDITIONS
		min.	typ.	max.	min.	typ.	max.		
V_{CC}	DC supply voltage $V_{CC} - \text{GND}$	2.0	5.0	10.0	4.5	5.0	5.5	V	see Figs 6 and 7
V_{CC}	DC supply voltage $V_{CC} - V_{EE}$	2.0	5.0	10.0	2.0	5.0	10.0	V	see Figs 6 and 7
V_I	DC input voltage range	GND		V_{CC}	GND		V_{CC}	V	
V_S	DC switch voltage range	V_{EE}		V_{CC}	V_{EE}		V_{CC}	V	
T_{amb}	operating ambient temperature range	-40		+85	-40		+85	°C	see DC and AC CHARACTERISTICS
T_{amb}	operating ambient temperature range	-40		+125	-40		+125	°C	
t_r, t_f	input rise and fall times		6.0	1000 500 400 250		6.0	500	ns	$V_{CC} = 2.0 \text{ V}$ $V_{CC} = 4.5 \text{ V}$ $V_{CC} = 6.0 \text{ V}$ $V_{CC} = 10.0 \text{ V}$

8-channel analog multiplexer/demultiplexer

74HC/HCT4051

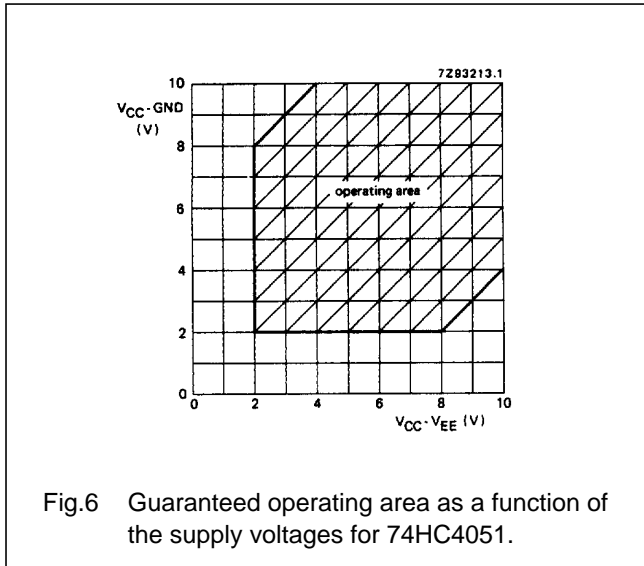

Fig.6 Guaranteed operating area as a function of the supply voltages for 74HC4051.

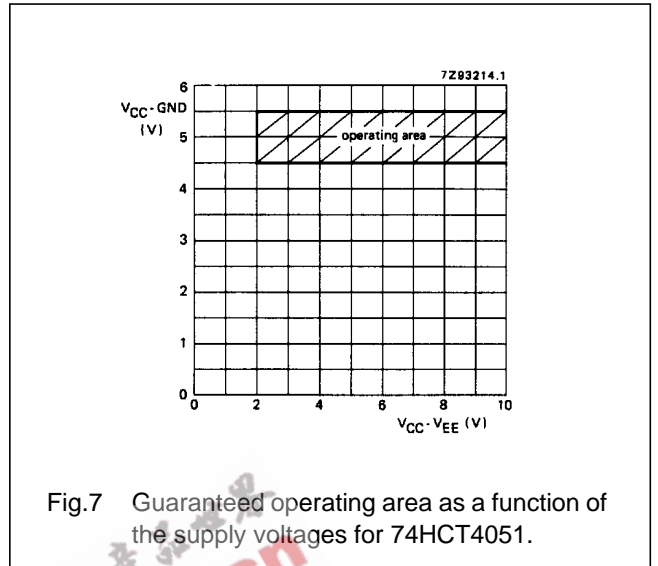

Fig.7 Guaranteed operating area as a function of the supply voltages for 74HCT4051.

DC CHARACTERISTICS FOR 74HC/HCT

For 74HC: $V_{CC} - GND$ or $V_{CC} - V_{EE} = 2.0, 4.5, 6.0$ and 9.0 V

For 74HCT: $V_{CC} - GND = 4.5$ and 5.5 V; $V_{CC} - V_{EE} = 2.0, 4.5, 6.0$ and 9.0 V

SYMBOL	PARAMETER	T_{amb} (°C)								UNIT	TEST CONDITIONS				
		74HC/HCT									V_{CC} (V)	V_{EE} (V)	I_S (μA)	V_{is}	V_I
		+25			-40 to +85		-40 to +125								
		min.	typ.	max.	min.	max.	min.	max.							
R_{ON}	ON resistance (peak)		-	-		-		-	Ω	2.0	0	100	V_{CC} to V_{EE}	V_{IH} or V_{IL}	
			100	180		225		270	Ω	4.5	0	1000			
			90	160		200		240	Ω	6.0	0	1000			
			70	130		165		195	Ω	4.5	-4.5	1000			
R_{ON}	ON resistance (rail)		150	-		-		-	Ω	2.0	0	100	V_{EE}	V_{IH} or V_{IL}	
			80	140		175		210	Ω	4.5	0	1000			
			70	120		150		180	Ω	6.0	0	1000			
			60	105		130		160	Ω	4.5	-4.5	1000			
R_{ON}	ON resistance (rail)		150	-		-		-	Ω	2.0	0	100	V_{CC}	V_{IH} or V_{IL}	
			90	160		200		240	Ω	4.5	0	1000			
			80	140		175		210	Ω	6.0	0	1000			
			65	120		150		180	Ω	4.5	-4.5	1000			
ΔR_{ON}	maximum ΔON resistance between any two channels		-						Ω	2.0	0		V_{CC} to V_{EE}	V_{IH} or V_{IL}	
			9						Ω	4.5	0				
			8						Ω	6.0	0				
			6						Ω	4.5	-4.5				

Notes to DC characteristics

- At supply voltages ($V_{CC} - V_{EE}$) approaching 2.0 V the analog switch ON-resistance becomes extremely non-linear. Therefore it is recommended that these devices be used to transmit digital signals only, when using these supply voltages.
- For test circuit measuring R_{ON} see Fig.8.

8-channel analog multiplexer/demultiplexer

74HC/HCT4051

DC CHARACTERISTICS FOR 74HC

Voltages are referenced to GND (ground = 0 V)

SYMBOL	PARAMETER	T _{amb} (°C)						UNIT	TEST CONDITIONS					
		74HC							V _{CC} (V)	V _{EE} (V)	V _i	OTHER		
		+25			-40 to +85		-40 to +125							
		min.	typ.	max.	min.	max.	min.						max.	
V _{IH}	HIGH level input voltage	1.5	1.2		1.5		1.5		V	2.0				
		3.15	2.4		3.15		3.15			4.5				
		4.2	3.2		4.2		4.2			6.0				
		6.3	4.7		6.3		6.3			9.0				
V _{IL}	LOW level input voltage		0.8	0.5		0.5		0.5	V	2.0				
			2.1	1.35		1.35		1.35		4.5				
			2.8	1.8		1.8		1.8		6.0				
			4.3	2.7		2.7		2.7		9.0				
± I _I	input leakage current			0.1		1.0		1.0	μA	6.0	0	V _{CC} or GND		
				0.2		2.0		2.0		10.0	0			
± I _S	analog switch OFF-state current per channel			0.1		1.0		1.0	μA	10.0	0	V _{IH} or V _{IL}	V _S = V _{CC} - V _{EE} Fig.10	
± I _S	analog switch OFF-state current all channels			0.4		4.0		4.0	μA	10.0	0	V _{IH} or V _{IL}	V _S = V _{CC} - V _{EE} Fig.10	
± I _S	analog switch ON-state current			0.4		4.0		4.0	μA	10.0	0	V _{IH} or V _{IL}	V _S = V _{CC} - V _{EE} Fig.11	
I _{CC}	quiescent supply current			8.0		80.0		160.0	μA	6.0	0	V _{CC} or GND	V _{is} = V _{EE} or V _{CC} ; V _{os} = V _{CC} or V _{EE}	
				16.0		160.0		320.0		10.0	0			

8-channel analog multiplexer/demultiplexer

74HC/HCT4051

AC CHARACTERISTICS FOR 74HC

GND = 0 V; $t_r = t_f = 6$ ns; $C_L = 50$ pF

SYMBOL	PARAMETER	T_{amb} (°C)								UNIT	TEST CONDITIONS		
		74HC									V_{CC} (V)	V_{EE} (V)	OTHER
		+25			-40 to +85		-40 to +125						
		min.	typ.	max.	min.	max.	min.	max.					
t_{PHL}/t_{PLH}	propagation delay V_{is} to V_{os}		14 5 4 4	60 12 10 8		75 15 13 10		90 18 15 12	ns	2.0 4.5 6.0 4.5	0 0 0 -4.5	$R_L = \infty$; $C_L = 50$ pF (see Fig.17)	
t_{PZH}/t_{PZL}	turn "ON" time \bar{E} to V_{os}		72 29 21 18	345 69 59 51		430 86 73 64		520 104 88 77	ns	2.0 4.5 6.0 4.5	0 0 0 -4.5	$R_L = 1$ k Ω ; $C_L = 50$ pF (see Fig.18, 19 and 20)	
t_{PZH}/t_{PZL}	turn "ON" time S_n to V_{os}		66 28 19 16	345 69 59 51		430 86 73 64		520 104 88 77	ns	2.0 4.5 6.0 4.5	0 0 0 -4.5	$R_L = 1$ k Ω ; $C_L = 50$ pF (see Fig.18, 19 and 20)	
t_{PHZ}/t_{PLZ}	turn "OFF" time \bar{E} to V_{os}		58 31 17 18	290 58 49 42		365 73 62 53		435 87 74 72	ns	2.0 4.5 6.0 4.5	0 0 0 -4.5	$R_L = 1$ k Ω ; $C_L = 50$ pF (see Fig.18, 19 and 20)	
t_{PHZ}/t_{PLZ}	turn "OFF" time S_n to V_{os}		61 25 18 18	290 58 49 42		365 73 62 53		435 87 74 72	ns	2.0 4.5 6.0 4.5	0 0 0 -4.5	$R_L = 1$ k Ω ; $C_L = 50$ pF (see Fig.18, 19 and 20)	

8-channel analog multiplexer/demultiplexer

74HC/HCT4051

DC CHARACTERISTICS FOR 74HCT

Voltages are referenced to GND (ground = 0)

SYMBOL	PARAMETER	T _{amb} (°C)								UNIT	TEST CONDITIONS			
		74HCT									V _{CC} (V)	V _{EE} (V)	V _i	OTHER
		+25			-40 to +85		-40 to +125							
		min.	typ.	max.	min.	max.	min.	max.						
V _{IH}	HIGH level input voltage	2.0	1.6		2.0		2.0		V	4.5 to 5.5				
V _{IL}	LOW level input voltage		1.2	0.8		0.8		0.8	V	4.5 to 5.5				
± I _I	input leakage current			0.1		1.0		1.0	µA	5.5	0	V _{CC} or GND		
± I _S	analog switch OFF-state current per channel			0.1		1.0		1.0	µA	10.0	0	V _{IH} or V _{IL}	V _S = V _{CC} - V _{EE} (see Fig.10)	
± I _S	analog switch OFF-state current all channels			0.4		4.0		4.0	µA	10.0	0	V _{IH} or V _{IL}	V _S = V _{CC} - V _{EE} (see Fig.10)	
± I _S	analog switch ON-state current			0.4		4.0		4.0	µA	10.0	0	V _{IH} or V _{IL}	V _S = V _{CC} - V _{EE} (see Fig.11)	
I _{CC}	quiescent supply current			8.0 16.0		80.0 160.0		160.0 320.0	µA	5.5 5.0	0 -5.0	V _{CC} or GND	V _{is} = V _{EE} or V _{CC} ; V _{os} = V _{CC} or V _{EE}	
ΔI _{CC}	additional quiescent supply current per input pin for unit load coefficient is 1 (note 1)		100	360		450		490	µA	4.5 to 5.5	0	V _{CC} - 2.1 V	other inputs at V _{CC} or GND	

Note to HCT types

- The value of additional quiescent supply current (Δ I_{CC}) for a unit load of 1 is given here. To determine Δ I_{CC} per input, multiply this value by the unit load coefficient shown in the table below.

INPUT	UNIT LOAD COEFFICIENT
S _n	0.50
E	0.50

8-channel analog multiplexer/demultiplexer

74HC/HCT4051

AC CHARACTERISTICS FOR 74HCT

GND = 0 V; $t_r = t_f = 6$ ns; $C_L = 50$ pF

SYMBOL	PARAMETER	T_{amb} (°C)						UNIT	TEST CONDITIONS		
		74HCT							V_{CC} (V)	V_{EE} (V)	OTHER
		+25			-40 to +85		-40 to +125				
		min.	typ.	max.	min.	max.	min.		max.		
t_{PHL}/t_{PLH}	propagation delay V_{is} to V_{os}	5	12		15		18	ns	4.5	0	$R_L = \infty$; $C_L = 50$ pF (see Fig.17)
		4	8		10		12		4.5	-4.5	
t_{PZH}/t_{PZL}	turn "ON" time \bar{E} to V_{os}	26	55		69		83	ns	4.5	0	$R_L = 1$ k Ω ; $C_L = 50$ pF (see Fig.18, 19 and 20)
		16	39		49		59		4.5	-4.5	
t_{PZH}/t_{PZL}	turn "ON" time S_n to V_{os}	28	55		69		83	ns	4.5	0	$R_L = 1$ k Ω ; $C_L = 50$ pF (see Fig.18, 19 and 20)
		16	39		49		59		4.5	-4.5	
t_{PHZ}/t_{PLZ}	turn "OFF" time \bar{E} to V_{os}	19	45		56		68	ns	4.5	0	$R_L = 1$ k Ω ; $C_L = 50$ pF (see Fig.18, 19 and 20)
		16	32		40		48		4.5	-4.5	
t_{PHZ}/t_{PLZ}	turn "OFF" time S_n to V_{os}	23	45		56		68	ns	4.5	0	$R_L = 1$ k Ω ; $C_L = 50$ pF (see Fig.18, 19 and 20)
		16	32		40		48		4.5	-4.5	

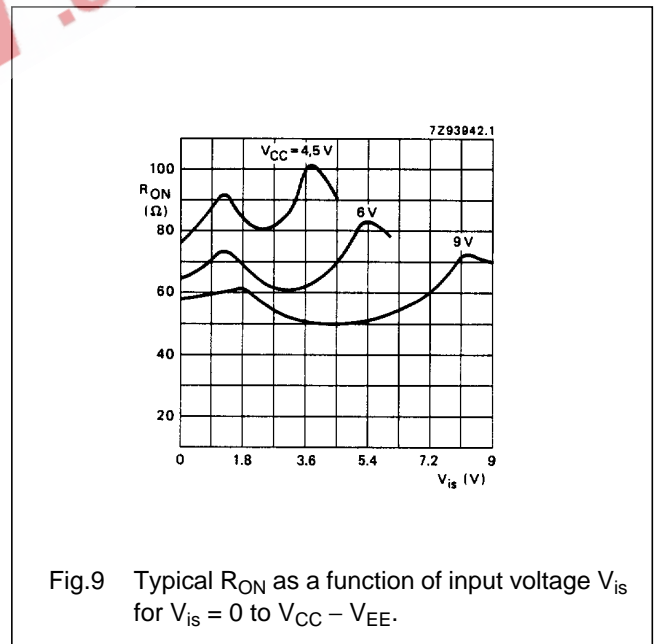
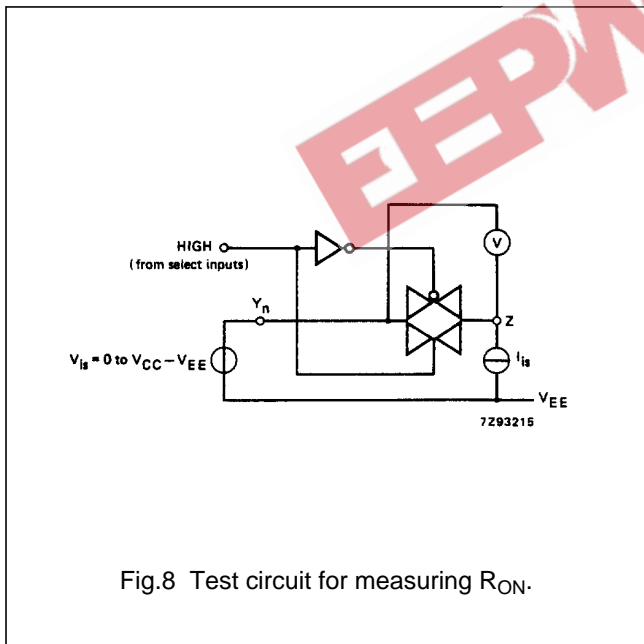

8-channel analog multiplexer/demultiplexer

74HC/HCT4051

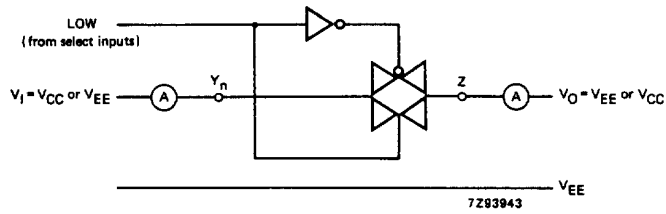

Fig.10 Test circuit for measuring OFF-state current.

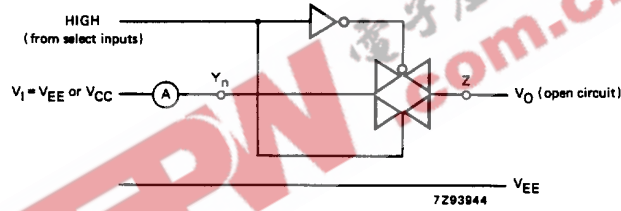

Fig.11 Test circuit for measuring ON-state current.

8-channel analog multiplexer/demultiplexer

74HC/HCT4051

ADDITIONAL AC CHARACTERISTICS FOR 74HC/HCT

Recommended conditions and typical values

GND = 0 V; T_{amb} = 25 °C

SYMBOL	PARAMETER	typ	UNIT	V _{CC} (V)	V _{EE} (V)	V _{is(p-p)} (V)	CONDITIONS
	sine-wave distortion f = 1 kHz	0.04 0.02	% %	2.25 4.5	-2.25 -4.5	4.0 8.0	R _L = 10 kΩ; C _L = 50 pF (see Fig.14)
	sine-wave distortion f = 10 kHz	0.12 0.06	% %	2.25 4.5	-2.25 -4.5	4.0 8.0	R _L = 10 kΩ; C _L = 50 pF (see Fig.14)
	switch "OFF" signal feed-through	-50 -50	dB dB	2.25 4.5	-2.25 -4.5	note 1	R _L = 600 Ω; C _L = 50 pF (see Figs 12 and 15)
V _(p-p)	crosstalk voltage between control and any switch (peak-to-peak value)	110 220	mV mV	4.5 4.5	0 -4.5		R _L = 600 Ω; C _L = 50 pF; f = 1 MHz (E or S _n , square-wave between V _{CC} and GND, t _r = t _f = 6 ns) (see Fig.16)
f _{max}	minimum frequency response (-3dB)	170 180	MHz MHz	2.25 4.5	-2.25 -4.5	note 2	R _L = 50 Ω; C _L = 10 pF (see Fig.13 and 14)
C _S	maximum switch capacitance independent (Y) common (Z)	5 25	pF pF				

Notes to AC characteristics

1. Adjust input voltage V_{is} to 0 dBm level (0 dBm = 1 mW into 600 Ω).
2. Adjust input voltage V_{is} to 0 dBm level at V_{os} for 1 MHz (0 dBm = 1 mW into 50 Ω).

General note

V_{is} is the input voltage at a Y_n or Z terminal, whichever is assigned as an input.
V_{os} is the output voltage at a Y_n or Z terminal, whichever is assigned as an output.

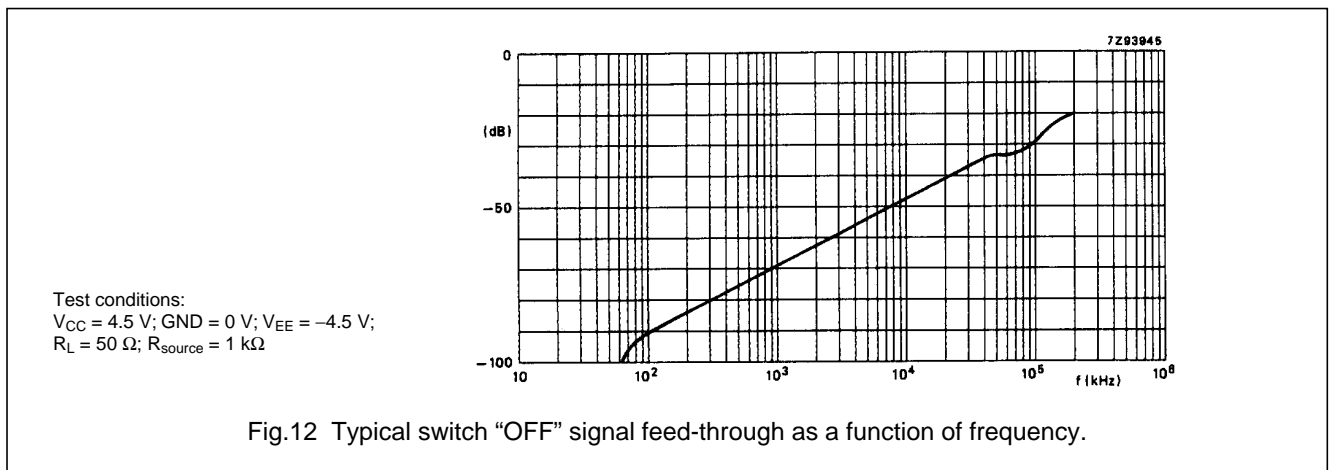

8-channel analog multiplexer/demultiplexer

74HC/HCT4051

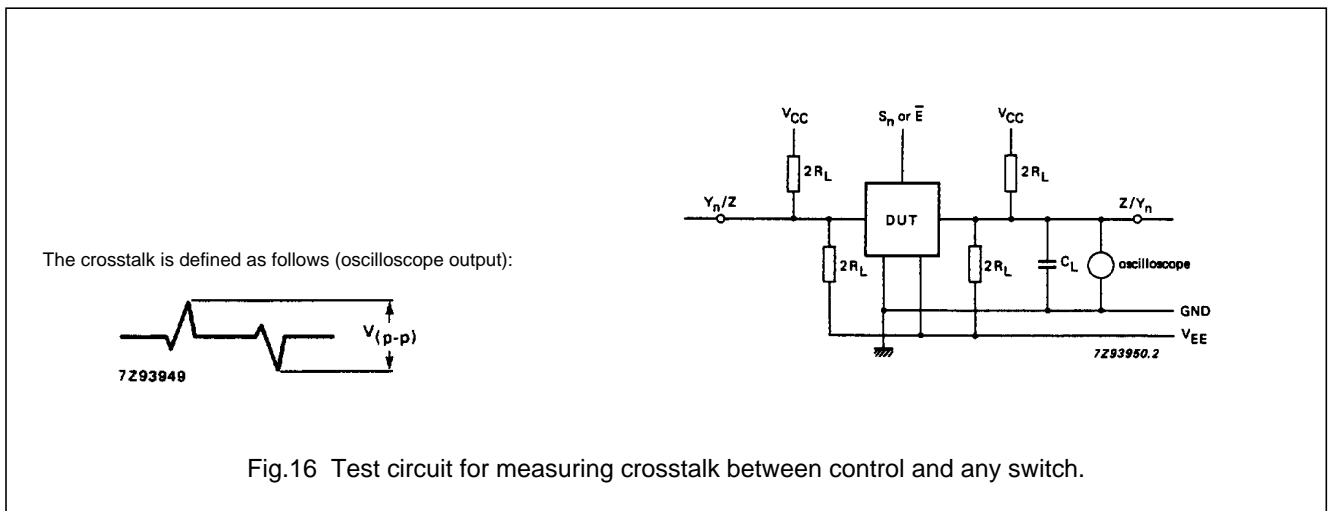
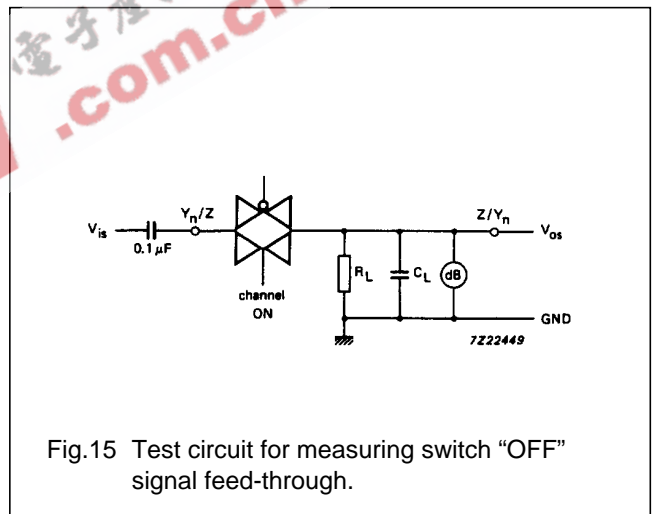
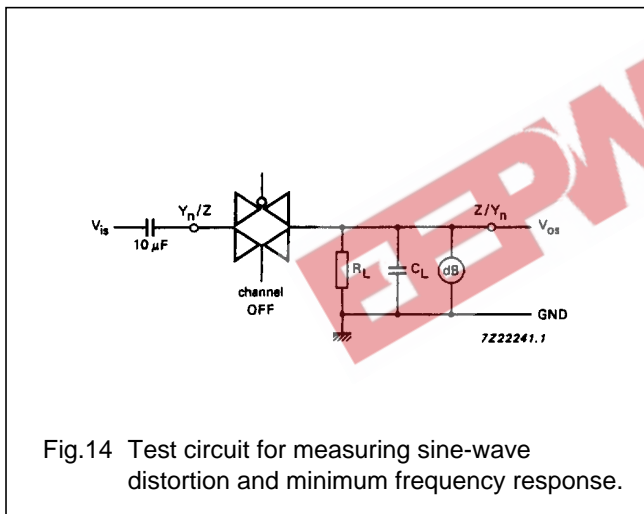
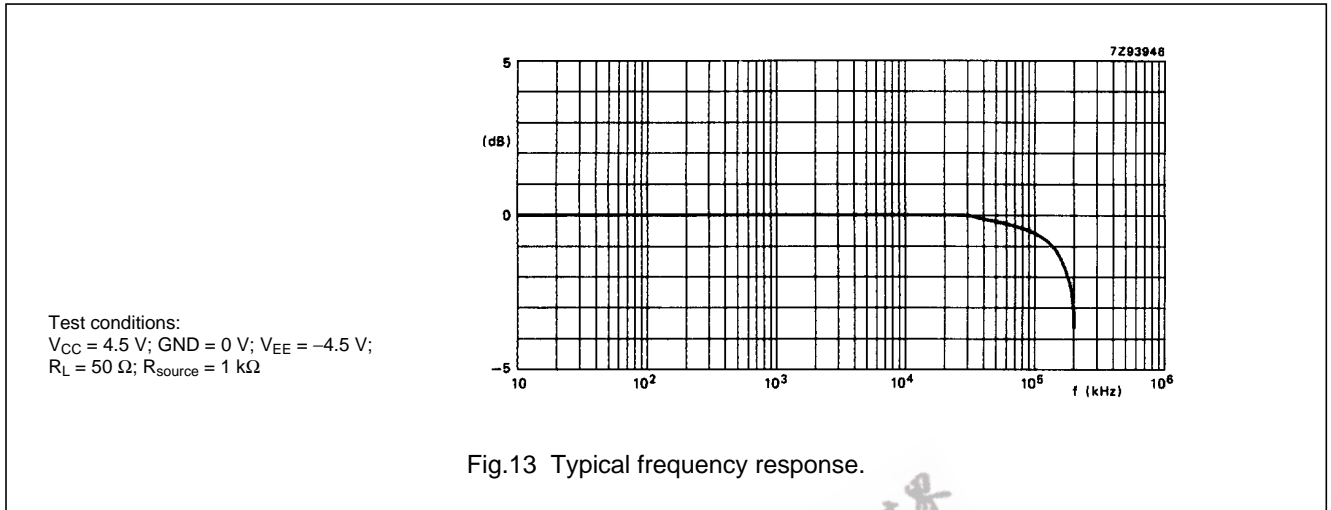

8-channel analog multiplexer/demultiplexer

74HC/HCT4051

AC WAVEFORMS

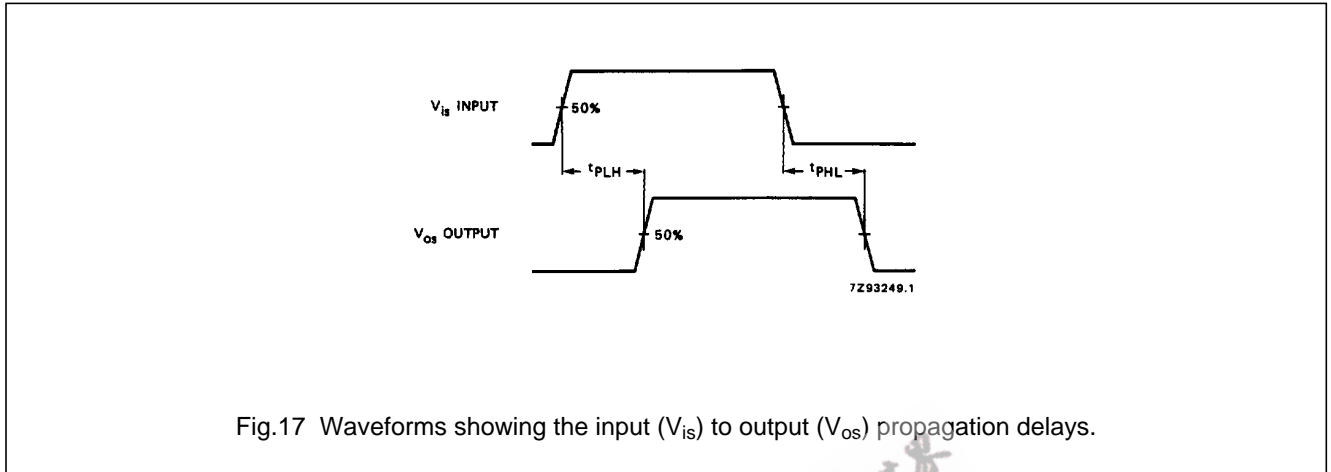

Fig.17 Waveforms showing the input (V_{is}) to output (V_{os}) propagation delays.

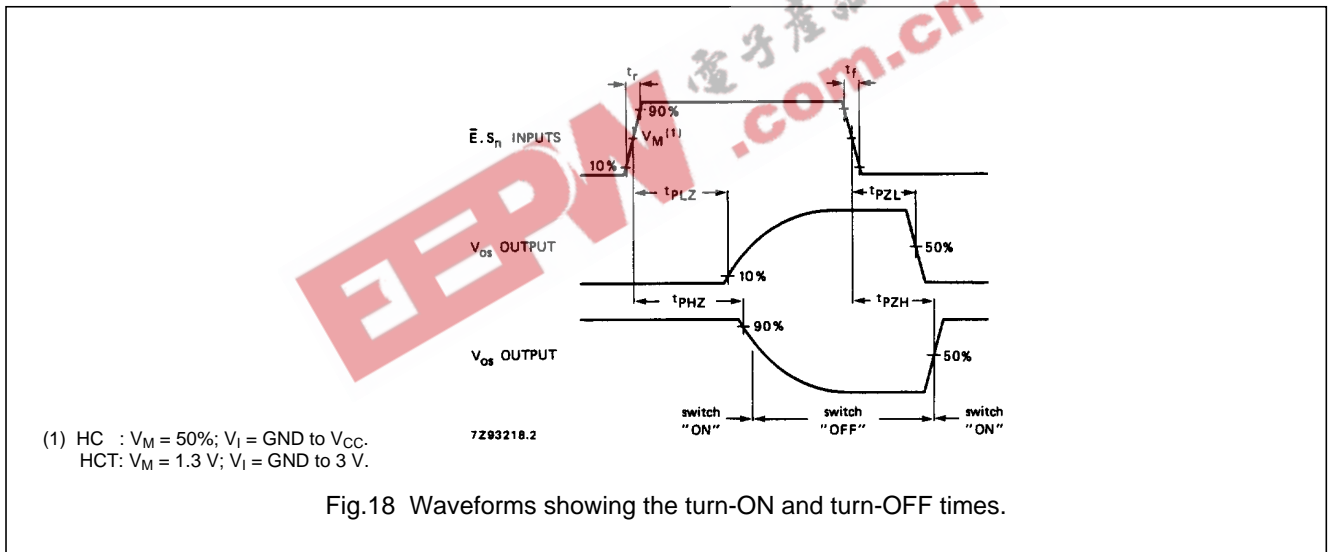
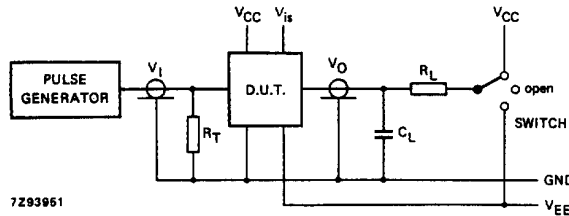

Fig.18 Waveforms showing the turn-ON and turn-OFF times.

8-channel analog multiplexer/demultiplexer

74HC/HCT4051

TEST CIRCUIT AND WAVEFORMS



Conditions

TEST	SWITCH	V _{is}
t _{PZH}	V _{EE}	V _{CC}
t _{PZL}	V _{CC}	V _{EE}
t _{PHZ}	V _{EE}	V _{CC}
t _{PLZ}	V _{CC}	V _{EE}
others	open	pulse

FAMILY	AMPLITUDE	V _M	t _r ; t _f	
			f _{max} ; PULSE WIDTH	OTHER
74HC	V _{CC}	50%	< 2 ns	6 ns
74HCT	3.0 V	1.3 V	< 2 ns	6 ns

C_L = load capacitance including jig and probe capacitance (see AC CHARACTERISTICS for values).

R_T = termination resistance should be equal to the output impedance Z_O of the pulse generator.

t_r = t_f = 6 ns; when measuring f_{max}, there is no constraint to t_r, t_f with 50% duty factor.

Fig.19 Test circuit for measuring AC performance.

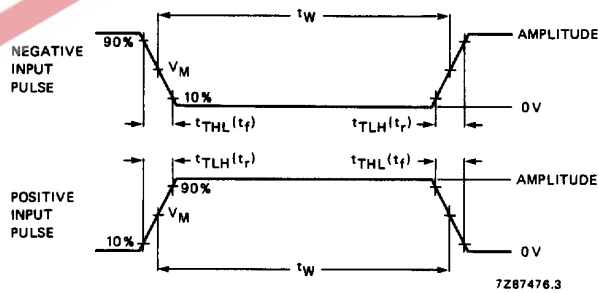

Conditions

TEST	SWITCH	V _{is}
t _{PZH}	V _{EE}	V _{CC}
t _{PZL}	V _{CC}	V _{EE}
t _{PHZ}	V _{EE}	V _{CC}
t _{PLZ}	V _{CC}	V _{EE}
others	open	pulse

FAMILY	AMPLITUDE	V _M	t _r ; t _f	
			f _{max} ; PULSE WIDTH	OTHER
74HC	V _{CC}	50%	< 2 ns	6 ns
74HCT	3.0 V	1.3 V	< 2 ns	6 ns

C_L = load capacitance including jig and probe capacitance (see AC CHARACTERISTICS for values).

R_T = termination resistance should be equal to the output impedance Z_O of the pulse generator.

t_r = t_f = 6 ns; when measuring f_{max}, there is no constraint to t_r, t_f with 50% duty factor.

Fig.20 Input pulse definitions.

8-channel analog multiplexer/demultiplexer

74HC/HCT4051

PACKAGE OUTLINES

See *"74HC/HCT/HCU/HCMOS Logic Package Outlines"*.

