

DATA SHEET

EEPW 电子产品世界
.com.cn

74ALS651/74ALS651-1

74ALS652/74ALS652-1

Transceiver/register

Product specification
IC05 Data Handbook

1991 Feb 08

Transceiver/register

74ALS651/74ALS651-1 74ALS652/74ALS652-1

74ALS651/651-1 *Octal transceiver/register, inverting (3-State)*
74ALS652/652-1 *Octal transceiver/register, non-inverting (3-State)*

FEATURES

- Independent registers for A and B buses
- Multiplexed real-time and stored data
- Choice of non-inverting and inverting data paths
- 3-State outputs
- The -1 versions sinks 48mA I_{OL} within the $\pm 5\%$ V_{CC} range

DESCRIPTION

The 74LAS651 and 74ALS652 transceivers/registers consist of bus transceiver circuits with 3-State outputs, D-type flip-flops, and control circuitry arranged for multiplexed transmission of data directly from the input bus or the internal registers. Data on the A or B bus will be clocked into the registers as the appropriate clock pin goes High. Output enable (OEAB, \overline{OEBA}) and select (SAB, SBA) pins are provided for bus management. The 74LAS651-1 and 74ALS652-1 will sink 48mA if the V_{CC} is limited to 5.0V \pm 0.25V.

TYPE	TYPICAL f_{MAX}	TYPICAL SUPPLY CURRENT (TOTAL)
74ALS651/74ALS651-1	140MHz	40mA
74ALS652/74ALS652-1	140MHz	46mA

ORDERING INFORMATION

DESCRIPTION	ORDER CODE	DRAWING NUMBER
	COMMERCIAL RANGE $V_{CC} = 5V \pm 10\%$, $T_{amb} = 0^{\circ}C$ to $+70^{\circ}C$	
24-pin plastic DIP	74ALS651N, 74ALS651-1N, 74ALS652N, 74ALS652-1N	SOT222-1
24-pin plastic SOL	74ALS651D, 74ALS651-1D, 74ALS652D, 74ALS652-1D	SOT137-1

INPUT AND OUTPUT LOADING AND FAN-OUT TABLE

PINS	DESCRIPTION	74ALS (U.L.) HIGH/LOW	LOAD VALUE HIGH/LOW
A0 – A7	A inputs	1.0/1.0	70 μ A/0.1mA
B0 – B7	B inputs	1.0/1.0	70 μ A/0.1mA
CPAB	A-to-B clock input	1.0/1.0	20 μ A/0.1mA
CPBA	B-to-A clock input	1.0/1.0	20 μ A/0.1mA
SAB	A-to-B select input	1.0/1.0	20 μ A/0.1mA
SBA	B-to-A select input	1.0/1.0	20 μ A/0.1mA
OEAB	A-to-B output enable input	1.0/1.0	20 μ A/0.1mA
\overline{OEBA}	B-to-A output enable input	1.0/1.0	20 μ A/0.1mA
A0 – A7, B0 – B7	A, B outputs	750/240	15mA/24mA
A0 – A7, B0 – B7	A, B outputs (-1 version)	750/480	15mA/48mA

NOTE: One (1.0) ALS unit load is defined as: 20 μ A in the High state and 0.1mA in the Low state.

Transceiver/register

74ALS651/74ALS651-1
74ALS652/74ALS652-1

PIN CONFIGURATION – 74ALS651/651-1

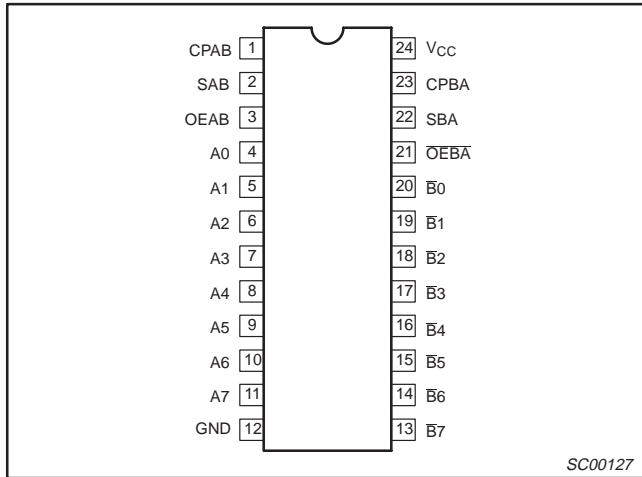

PIN CONFIGURATION – 74ALS652/652-1

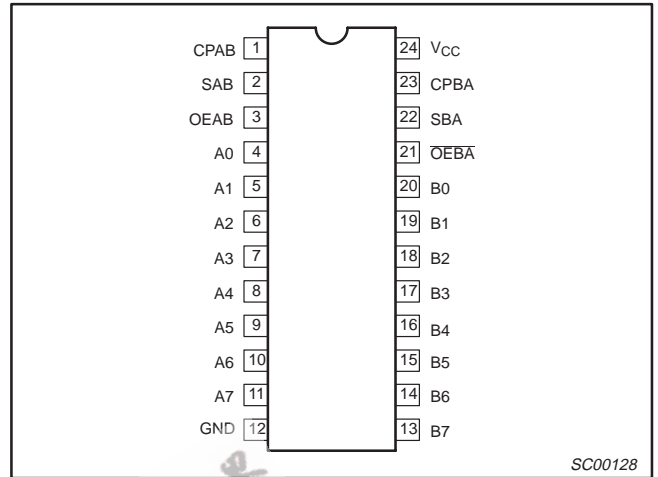

LOGIC SYMBOL – 74ALS651/651-1

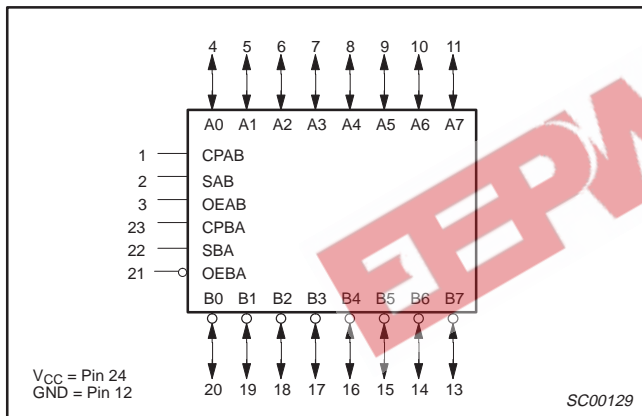

LOGIC SYMBOL – 74ALS652/652-1

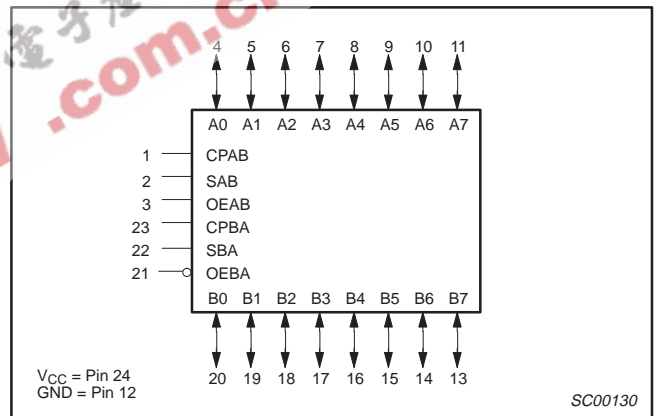

IEC/IEEE SYMBOL – 74ALS651/651-1

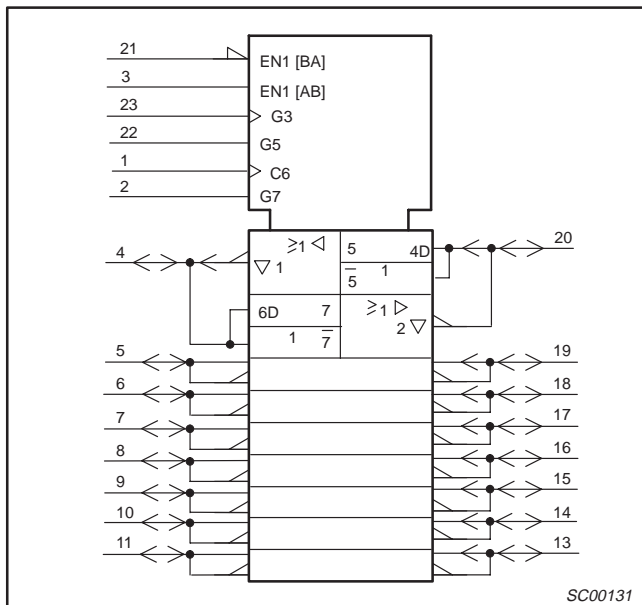

IEC/IEEE SYMBOL – 74ALS652/652-1

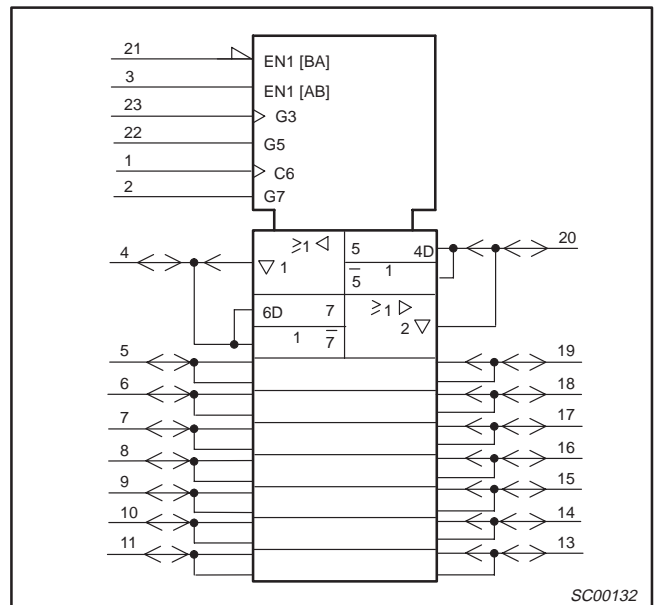

Transceiver/register

74ALS651/74ALS651-1
74ALS652/74ALS652-1

BUS MANAGEMENT FUNCTIONS

The following examples demonstrate the four fundamental bus-management functions that can be performed with the 74ALS651/74ALS651-1 and 74ALS652/74ALS652-1. The select pins determine whether data is stored or transferred through the device in real time. The output enable pins determine the direction of the data flow.

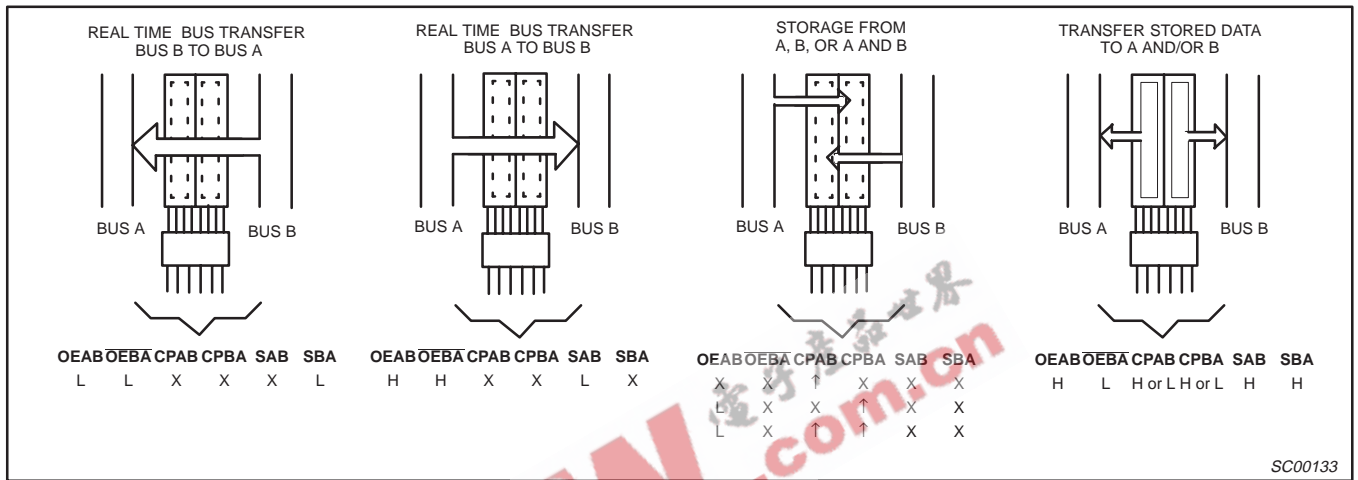

Transceiver/register

74ALS651/74ALS651-1
74ALS652/74ALS652-1

LOGIC DIAGRAM – 74ALS651/651-1

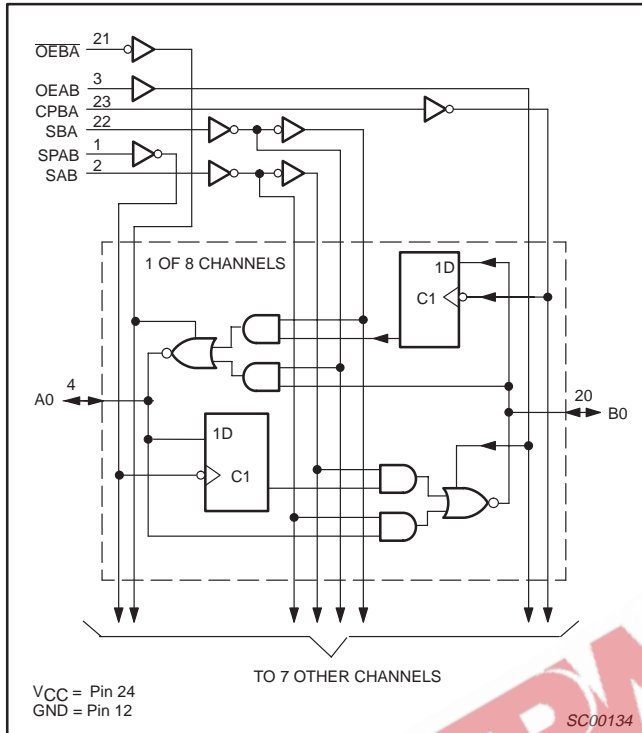

LOGIC DIAGRAM – 74ALS652/652-1

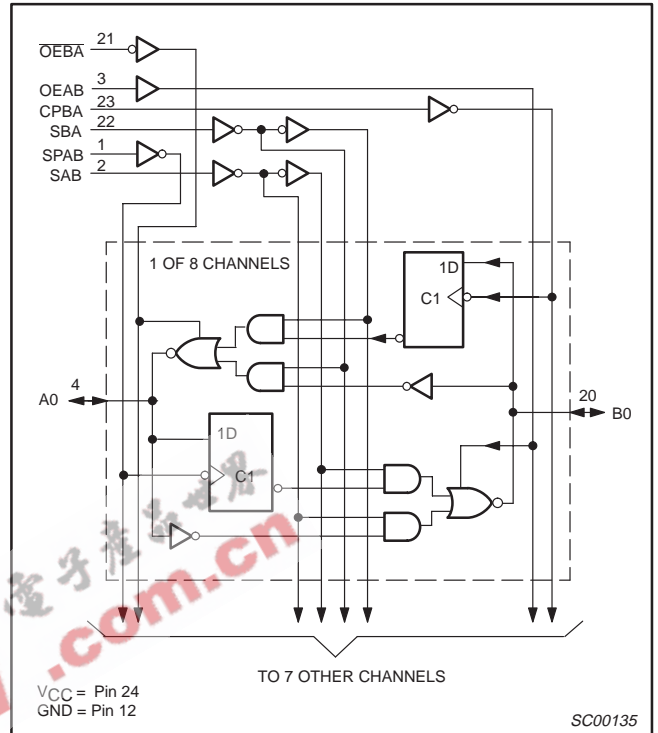

FUNCTION TABLE

INPUTS						DATA I/O		OPERATING MODE	
OEAB	OEBA	CPAB	CPBA	SAB	SBA	An	Bn	74ALS651/74ALS651-1	74ALS652/74ALS652-1
L	H	H or L	H or L	X	X	Input	Input	Isolation	Isolation
L	H	↑	↑	X	X	Input	Input	Store A and B data	Store A and B data
X	H	↑	H or L	X	X	Input	Unspecified*	Store A, hold B	Store A, hold B
H	H	↑	↑	L	X	Input	Output	Store A in both registers	Store A in both registers
L	X	H or L	↑	X	S	Unspecified*	Input	Hold A, store B	Hold A, store B
L	L	↑	↑	X	L	Output	Input	Store B in both registers	Store B in both registers
L	L	X	X	X	L	Output	Input	Real time \bar{B} data to A bus	Real time \bar{B} data to A bus
L	L	X	H or L	X	H	Output	Input	Stored \bar{B} data to A bus	Stored B data to A bus
H	H	X	X	L	X	Input	Output	Real time \bar{A} data to B bus	Real time A data to B bus
H	H	H or L	X	H	X	Input	Output	Stored \bar{A} data to B bus	Stored A data to B bus
H	L	H or L	H or L	H	H	Output	Output	Stored \bar{A} data to B bus	Stored A data to B bus
H	L	H or L	H or L	H	H	Output	Output	Stored \bar{B} data to A bus	Stored B data to A bus

NOTES:

H = High voltage level

L = Low voltage level

X = Don't care

* = The data output function may be enabled or disabled by various signals at the \overline{OE} and DIR inputs. Data input functions are always enabled, i.e., data at the bus pins will be stored on every Low-to-High transition of the clock.

↑ = Low-to-High clock transition

Transceiver/register

74ALS651/74ALS651-1
74ALS652/74ALS652-1**ABSOLUTE MAXIMUM RATINGS**

(Operation beyond the limit set forth in this table may impair the useful life of the device.
Unless otherwise noted these limits are over the operating free-air temperature range.)

SYMBOL	PARAMETER	RATING	UNIT
V_{CC}	Supply voltage	-0.5 to +7.0	V
V_{IN}	Input voltage	-0.5 to +7.0	V
I_{IN}	Input current	-30 to +5	mA
V_{OUT}	Voltage applied to output in High output state	-0.5 to V_{CC}	V
I_{OUT}	Current applied to output in Low output state	All versions	48
		-1 version	96
T_{amb}	Operating free-air temperature range	0 to +70	°C
T_{stg}	Storage temperature range	-65 to +150	°C

RECOMMENDED OPERATING CONDITIONS

SYMBOL	PARAMETER	LIMITS			UNIT
		MIN	NOM	MAX	
V_{CC}	Supply voltage	4.5	5.0	5.5	V
V_{IH}	High-level input voltage	2.0			V
V_{IL}	Low-level input voltage			0.8	V
I_{IK}	Input clamp current			-18	mA
I_{OH}	High-level output current			-15	mA
I_{OL}	Low-level output current	All versions		24	mA
		-1 version		48 ¹	mA
T_{amb}	Operating free-air temperature range	0		+70	°C

NOTE:

1. The 48mA limit applies only under the condition of $V_{CC} = 5.0V \pm 5\%$.

Transceiver/register

74ALS651/74ALS651-1
74ALS652/74ALS652-1

DC ELECTRICAL CHARACTERISTICS

(Over recommended operating free-air temperature range unless otherwise noted.)

SYMBOL	PARAMETER		TEST CONDITIONS ¹		LIMITS			UNIT	
					MIN	TYP ²	MAX		
V _{OH}	High-level output voltage		V _{CC} ±10%, V _{IL} = MAX, V _{IH} = MIN	I _{OH} = -0.4mA	V _{CC} - 2			V	
				I _{OH} = -3mA	2.4	3.2		V	
			V _{CC} = MIN, V _{IL} = MAX, V _{IH} = MIN	I _{OH} = -15mA	2.0			V	
V _{OL}	Low-level output voltage	All versions	V _{CC} = MIN, V _{IL} = MAX, V _{IH} = MIN	I _{OL} = 12mA		0.25	0.40	V	
				I _{OL} = 24mA		0.35	0.50	V	
		-1 versions	V _{CC} = 4.75V, V _{IL} = MAX, V _{IH} = MIN	I _{OL} = 48mA		0.35	0.50	V	
V _{IK}	Input clamp voltage		V _{CC} = MIN, I _I = I _{IK}			-0.73	-1.5	V	
I _I	Input current at maximum input voltage	control inputs	V _{CC} = MAX, V _I = 7.0V				0.1	mA	
		A or B ports	V _{CC} = MAX, V _I = 5.5V				0.1	mA	
I _{IH}	High-level input current ³		V _{CC} = MAX, V _I = 2.7V				20	μA	
I _{IL}	Low-level input current ³		V _{CC} = MAX, V _I = 0.4V				-0.1	mA	
I _O	Output current ⁴		V _{CC} = MAX, V _O = 2.25V			-30	-112	mA	
I _{CC}	Supply current (total)		74ALS651/ 74ALS651-1	I _{CC} H	V _{CC} = MAX		32	50	mA
				I _{CC} L			45	68	mA
				I _{CC} Z			44	68	mA
			74ALS652/ 74ALS652-1	I _{CC} H			36	58	mA
				I _{CC} L			53	78	mA
				I _{CC} Z			49	72	mA

NOTES:

- For conditions shown as MIN or MAX, use the appropriate value specified under recommended operating conditions for the applicable type.
- All typical values are at V_{CC} = 5V, T_{amb} = 25°C.
- For I/O ports, the parameter I_{IH} and I_{IL} include the off-state current.
- The output conditions have been chosen to produce a current that closely approximates one half of the true short-circuit output current, I_{OS}.

AC ELECTRICAL CHARACTERISTICS FOR 74ALS651/74ALS651-1

SYMBOL	PARAMETER	TEST CONDITION	LIMITS		UNIT
			T _{amb} = 0°C to +70°C V _{CC} = +5.0V ± 10% C _L = 50pF, R _L = 500Ω		
			MIN	MAX	
f _{max}	Maximum clock frequency	Waveform 1	100		MHz
t _{PLH} t _{PHL}	Propagation delay CPBA to An, CPAB to Bn	Waveform 1	5.0 6.0	13.0 13.0	ns
t _{PLH} t _{PHL}	Propagation delay An to Bn or Bn to An	Waveform NO TAG, 3	1.0 2.0	7.0 9.0	ns
t _{PLH} t _{PHL}	Propagation delay SBA to An or SAB to Bn (A or B Low)	Waveform NO TAG, 3	6.0 5.0	14.0 11.0	ns
t _{PLH} t _{PHL}	Propagation delay SBA to An or SAB to Bn (A or B High)	Waveform NO TAG, 3	4.0 5.0	11.0 12.0	ns
t _{PZH} t _{PZL}	Output enable time OEBA to An	Waveform 7 Waveform 8	2.0 5.0	8.0 12.0	ns
t _{PHZ} t _{PLZ}	Output disable time OEBA to An	Waveform 7 Waveform 8	2.0 3.0	8.0 10.0	ns
t _{PZH} t _{PZL}	Output enable time OEAB to Bn	Waveform 7 Waveform 8	2.0 5.0	9.0 12.0	ns
t _{PHZ} t _{PLZ}	Output disable time OEAB to Bn	Waveform 7 Waveform 8	3.0 5.0	11.0 13.0	ns

Transceiver/register

74ALS651/74ALS651-1
74ALS652/74ALS652-1

AC ELECTRICAL CHARACTERISTICS FOR 74ALS652/74ALS652-1

SYMBOL	PARAMETER	TEST CONDITION	LIMITS		UNIT
			$T_{amb} = 0^{\circ}\text{C to } +70^{\circ}\text{C}$ $V_{CC} = +5.0\text{V} \pm 10\%$ $C_L = 50\text{pF}, R_L = 500\Omega$		
			MIN	MAX	
f_{max}	Maximum clock frequency	Waveform 1	100		MHz
t_{PLH} t_{PHL}	Propagation delay CPBA to An, CPAB to Bn	Waveform 1	5.0 6.0	13.0 13.0	ns
t_{PLH} t_{PHL}	Propagation delay An to Bn or Bn to An	Waveform NO TAG, 3	2.0 4.0	8.0 9.0	ns
t_{PLH} t_{PHL}	Propagation delay SBA to An or SAB to Bn (A or B Low)	Waveform NO TAG, 3	4.0 5.0	11.0 11.0	ns
t_{PLH} t_{PHL}	Propagation delay SBA to An or SAB to Bn (A or B High)	Waveform NO TAG, 3	6.0 5.0	14.0 11.0	ns
t_{pZH} t_{pZL}	Output enable time $\overline{\text{OEBA}}$ to An	Waveform 7 Waveform 8	2.0 5.0	8.0 11.0	ns
t_{pHZ} t_{pLZ}	Output disable time $\overline{\text{OEBA}}$ to An	Waveform 7 Waveform 8	2.0 3.0	8.0 10.0	ns
t_{pZH} t_{pZL}	Output enable time OEAB to Bn	Waveform 7 Waveform 8	2.0 5.0	9.0 11.0	ns
t_{pHZ} t_{pLZ}	Output disable time OEAB to Bn	Waveform 7 Waveform 8	3.0 5.0	11.0 13.0	ns

AC SETUP REQUIREMENTS

SYMBOL	PARAMETER	TEST CONDITION	LIMITS		UNIT
			$T_{amb} = 0^{\circ}\text{C to } +70^{\circ}\text{C}$ $V_{CC} = +5.0\text{V} \pm 10\%$ $C_L = 50\text{pF}, R_L = 500\Omega$		
			MIN	MAX	
$t_{su} (H)$ $t_{su} (L)$	Setup time, High or Low An or Bn to CPAB or CPBA	Waveform 4	5.0 5.0		ns
$t_h (H)$ $t_h (L)$	Hold time, High or Low An or Bn to CPAB or CPBA	Waveform 4	0.0 1.0		ns
$t_{su} (H)$ $t_{su} (L)$	Setup time, High or Low ¹ $\overline{\text{OEBA}}$ to OEAB or OEAB to $\overline{\text{OEBA}}$	Waveform 5, 6	5.0 5.0		ns
$t_h (H)$ $t_h (L)$	Hold time, High or Low $\overline{\text{OEBA}}$ to OEAB or OEAB to $\overline{\text{OEBA}}$	Waveform 5, 6	0.0 0.0		ns
$t_w (H)$ $t_w (L)$	Pulse width, High or Low CPAB or CPBA	Waveform 1	6.0 4.0		ns

NOTE:

1. Setup time is to protect against current surge caused by enabling 16 outputs (24mA per output) simultaneously.

Transceiver/register

74ALS651/74ALS651-1 74ALS652/74ALS652-1

AC WAVEFORMS

For all waveforms, $V_M = 1.3V$.

The shaded areas indicate when the input is permitted to change for predictable output performance.

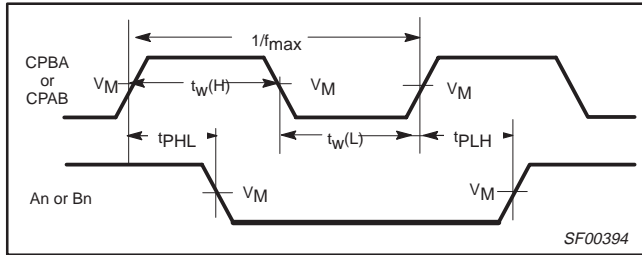

Waveform 1. Propagation Delay for Clock Input to Output, Clock Pulse Width, and Maximum Clock Frequency

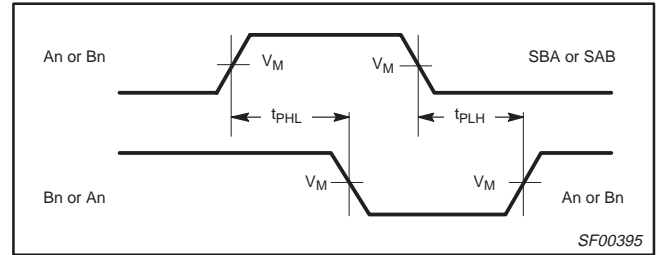

Waveform 2. Propagation Delay for An to Bn or Bn to An and SAB or SBA to An or Bn

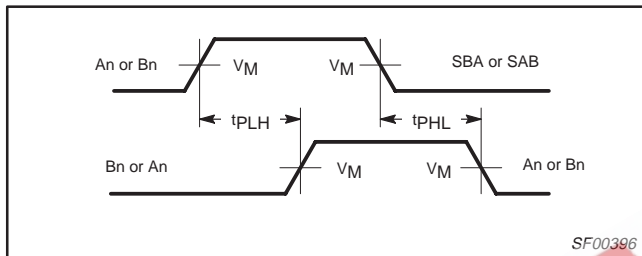

Waveform 3. Propagation Delay for An to Bn or Bn to An and SAB or SBA to An or Bn

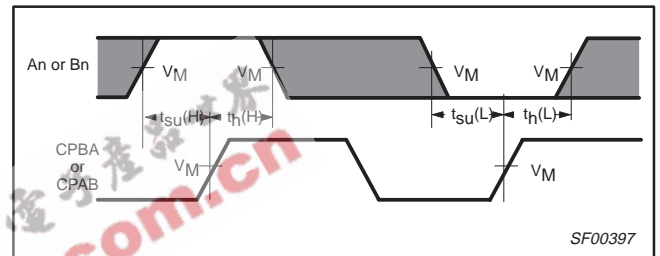

Waveform 4. Data Setup Time and Hold Times

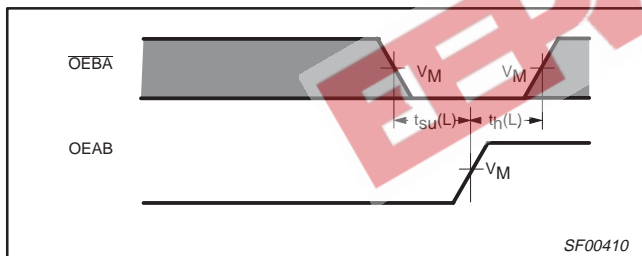

Waveform 5. OEBA to OEAB Setup Time and Hold Times

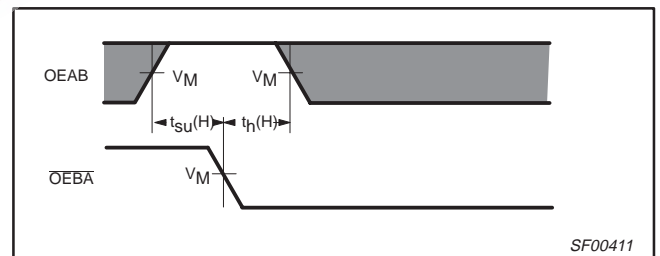

Waveform 6. OEAB to OEBA Setup Time and Hold Times

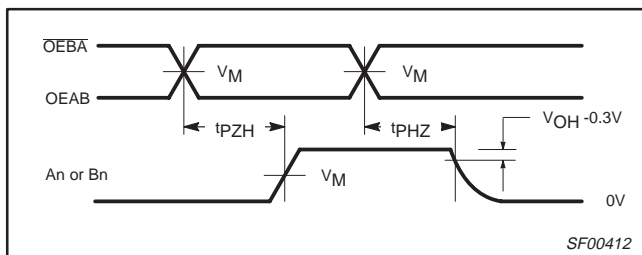

Waveform 7. 3-State Output Enable Time to High Level and Output Disable Time from High Level

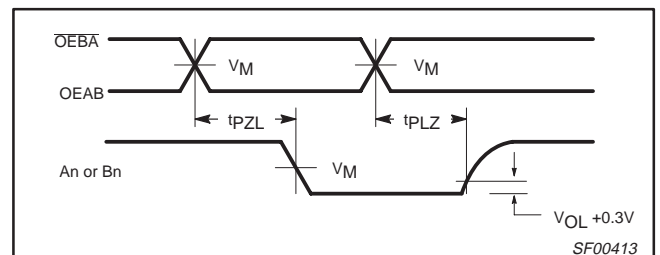

Waveform 8. 3-State Output Enable Time to Low Level and Output Disable Time from Low Level

Transceiver/register

74ALS651/74ALS651-1
74ALS652/74ALS652-1

TEST CIRCUIT AND WAVEFORMS

Test Circuit for 3-State and Open Collector Outputs

SWITCH POSITION

TEST	SWITCH
t_{PLZ} , t_{PZL}	closed
open collector	closed
All other	open

DEFINITIONS:
 R_L = Load resistor; see AC electrical characteristics for value.
 C_L = Load capacitance includes jig and probe capacitance; see AC electrical characteristics for value.
 R_T = Termination resistance should be equal to Z_{OUT} of pulse generators.

Input Pulse Definition

Family	INPUT PULSE REQUIREMENTS					
	Amplitude	V_M	Rep.Rate	t_w	t_{TLH}	t_{THL}
74ALS	3.5V	1.3V	1MHz	500ns	2.0ns	2.0ns

SC00126

Transceiver/register

74ALS651/74ALS651-1
74ALS652/74ALS652-1

DIP24: plastic dual in-line package; 24 leads (300 mil)

SOT222-1

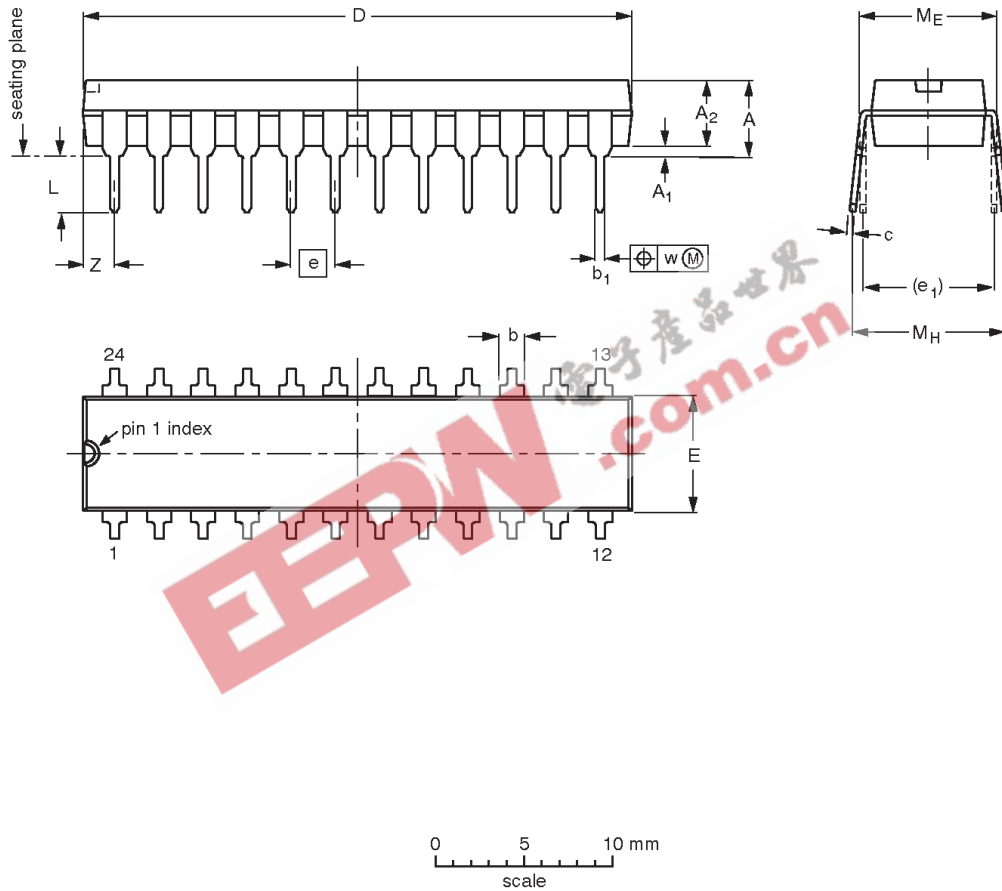

DIMENSIONS (millimetre dimensions are derived from the original inch dimensions)

UNIT	A max.	A ₁ min.	A ₂ max.	b	b ₁	c	D ⁽¹⁾	E ⁽¹⁾	e	e ₁	L	M _E	M _H	w	Z ⁽¹⁾ max.
mm	4.70	0.38	3.94	1.63 1.14	0.56 0.43	0.36 0.25	31.9 31.5	6.73 6.48	2.54	7.62	3.51 3.05	8.13 7.62	10.03 7.62	0.25	2.05
inches	0.185	0.015	0.155	0.064 0.045	0.022 0.017	0.014 0.010	1.256 1.240	0.265 0.255	0.100	0.300	0.138 0.120	0.32 0.30	0.395 0.300	0.01	0.081

Note

1. Plastic or metal protrusions of 0.01 inches maximum per side are not included.

OUTLINE VERSION	REFERENCES				EUROPEAN PROJECTION	ISSUE DATE
	IEC	JEDEC	EIAJ			
SOT222-1		MS-001AF				95-03-11

Transceiver/register

74ALS651/74ALS651-1
74ALS652/74ALS652-1

SO24: plastic small outline package; 24 leads; body width 7.5 mm

SOT137-1

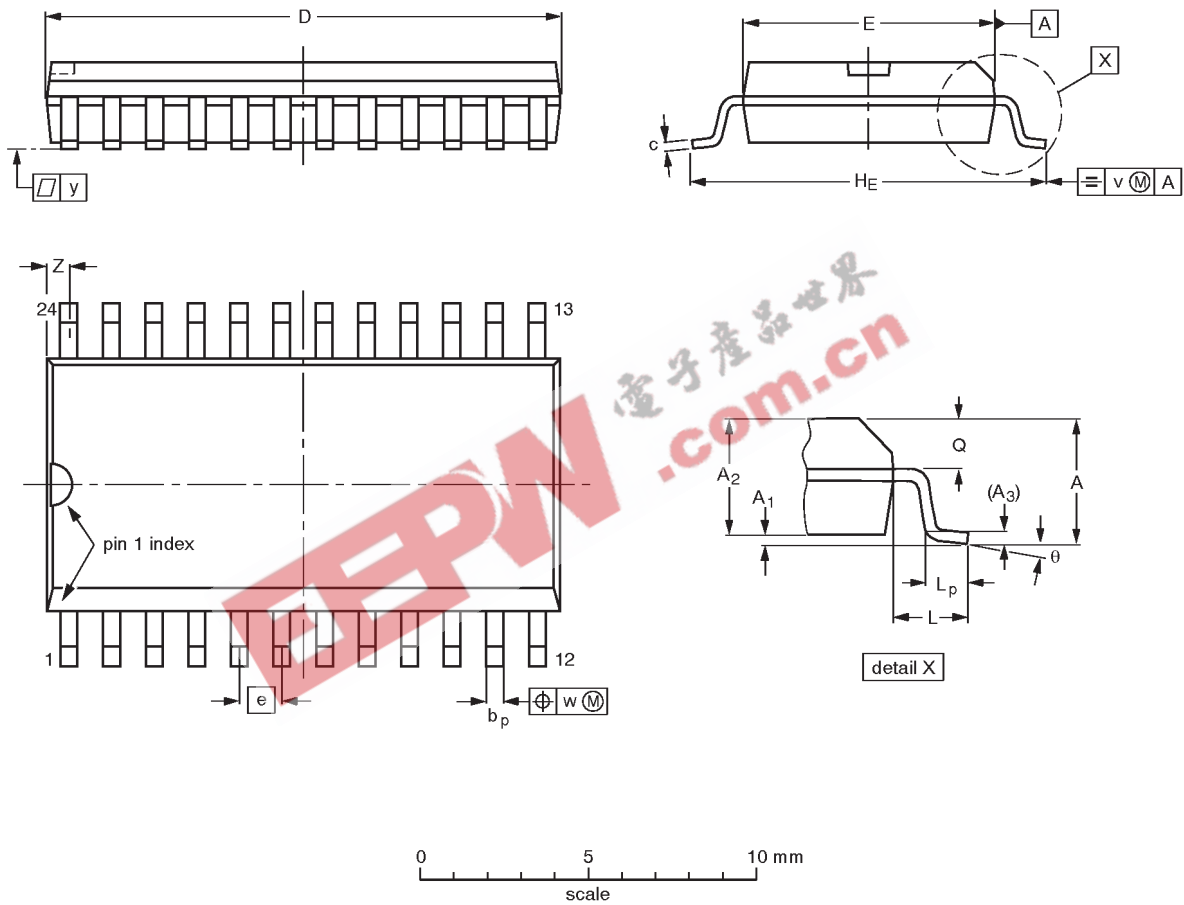

DIMENSIONS (inch dimensions are derived from the original mm dimensions)

UNIT	A max.	A ₁	A ₂	A ₃	b _p	c	D ⁽¹⁾	E ⁽¹⁾	e	H _E	L	L _p	Q	v	w	y	Z ⁽¹⁾	θ
mm	2.65	0.30 0.10	2.45 2.25	0.25	0.49 0.36	0.32 0.23	15.6 15.2	7.6 7.4	1.27	10.65 10.00	1.4	1.1 0.4	1.1 1.0	0.25	0.25	0.1	0.9 0.4	8° 0°
inches	0.10	0.012 0.004	0.096 0.089	0.01	0.019 0.014	0.013 0.009	0.61 0.60	0.30 0.29	0.050	0.42 0.39	0.055	0.043 0.016	0.043 0.039	0.01	0.01	0.004	0.035 0.016	

Note

1. Plastic or metal protrusions of 0.15 mm maximum per side are not included.

OUTLINE VERSION	REFERENCES				EUROPEAN PROJECTION	ISSUE DATE
	IEC	JEDEC	EIAJ			
SOT137-1	075E05	MS-013AD				-92-11-17 95-01-24

Transceiver/register

74ALS651/74ALS651-1
74ALS652/74ALS652-1

DEFINITIONS

Data Sheet Identification	Product Status	Definition
<i>Objective Specification</i>	Formative or in Design	This data sheet contains the design target or goal specifications for product development. Specifications may change in any manner without notice.
<i>Preliminary Specification</i>	Preproduction Product	This data sheet contains preliminary data, and supplementary data will be published at a later date. Philips Semiconductors reserves the right to make changes at any time without notice in order to improve design and supply the best possible product.
<i>Product Specification</i>	Full Production	This data sheet contains Final Specifications. Philips Semiconductors reserves the right to make changes at any time without notice, in order to improve design and supply the best possible product.

Philips Semiconductors and Philips Electronics North America Corporation reserve the right to make changes, without notice, in the products, including circuits, standard cells, and/or software, described or contained herein in order to improve design and/or performance. Philips Semiconductors assumes no responsibility or liability for the use of any of these products, conveys no license or title under any patent, copyright, or mask work right to these products, and makes no representations or warranties that these products are free from patent, copyright, or mask work right infringement, unless otherwise specified. Applications that are described herein for any of these products are for illustrative purposes only. Philips Semiconductors makes no representation or warranty that such applications will be suitable for the specified use without further testing or modification.

LIFE SUPPORT APPLICATIONS

Philips Semiconductors and Philips Electronics North America Corporation Products are not designed for use in life support appliances, devices, or systems where malfunction of a Philips Semiconductors and Philips Electronics North America Corporation Product can reasonably be expected to result in a personal injury. Philips Semiconductors and Philips Electronics North America Corporation customers using or selling Philips Semiconductors and Philips Electronics North America Corporation Products for use in such applications do so at their own risk and agree to fully indemnify Philips Semiconductors and Philips Electronics North America Corporation for any damages resulting from such improper use or sale.

Philips Semiconductors
811 East Arques Avenue
P.O. Box 3409
Sunnyvale, California 94088-3409
Telephone 800-234-7381

© Copyright Philips Electronics North America Corporation 1997
All rights reserved. Printed in U.S.A.

Let's make things better.