

# DATA SHEET

For a complete data sheet, please also download:

- The IC06 74HC/HCT/HCU/HCMOS Logic Family Specifications
- The IC06 74HC/HCT/HCU/HCMOS Logic Package Information
- The IC06 74HC/HCT/HCU/HCMOS Logic Package Outlines

EEPW 电子产品世界  
.com.cn

## 74HC/HCT4516 Binary up/down counter

Product specification  
File under Integrated Circuits, IC06

December 1990

## Binary up/down counter

## 74HC/HCT4516

## FEATURES

- Output capability: standard
- I<sub>CC</sub> category: MSI

## GENERAL DESCRIPTION

The 74HC/HCT4516 are high-speed Si-gate CMOS devices and are pin compatible with the “4516” of the “4000B” series. They are specified in compliance with JEDEC standard no. 7A.

The 74HC/HCT4516 are edge-triggered synchronous up/down 4-bit binary counters with a clock input (CP), an up/down count control input (UP/DN), an active LOW count enable input (CE), an asynchronous active HIGH

parallel load input (PL), four parallel inputs (D<sub>0</sub> to D<sub>3</sub>), four parallel outputs (Q<sub>0</sub> to Q<sub>3</sub>), an active LOW terminal count output ( $\overline{TC}$ ), and an overriding asynchronous master reset input (MR).

Information on D<sub>0</sub> to D<sub>3</sub> is loaded into the counter while PL is HIGH, independent of all other input conditions except the MR input, which must be LOW. When PL and  $\overline{CE}$  are LOW, the counter changes on the LOW-to-HIGH transition of CP. UP/ $\overline{DN}$  determines the direction of the count, HIGH for counting up, LOW for counting down. When counting up,  $\overline{TC}$  is LOW when Q<sub>0</sub> to Q<sub>3</sub> are HIGH and  $\overline{CE}$  is LOW. When counting down,  $\overline{TC}$  is LOW when Q<sub>0</sub> to Q<sub>3</sub> and  $\overline{CE}$  are LOW. A HIGH on MR resets the counter (Q<sub>0</sub> to Q<sub>3</sub> = LOW) independent of all other input conditions.

Logic equation for terminal count:

$$\overline{TC} = \overline{CE} \cdot \{(\overline{UP/DN}) \cdot Q_0 \cdot Q_1 \cdot Q_2 \cdot Q_3 + (\overline{UP/DN}) \cdot \overline{Q_0} \cdot \overline{Q_1} \cdot \overline{Q_2} \cdot \overline{Q_3}\}$$

## QUICK REFERENCE DATA

GND = 0 V; T<sub>amb</sub> = 25 °C; t<sub>r</sub> = t<sub>f</sub> = 6 ns

SYMBOL	PARAMETER	CONDITIONS	TYPICAL		UNIT
			HC	HCT	
t <sub>PHL</sub> /t <sub>PLH</sub>	propagation delay CP to Q <sub>n</sub>	C <sub>L</sub> = 15 pF; V <sub>CC</sub> = 5 V	19	19	ns
f <sub>max</sub>	maximum clock frequency		45	57	MHz
C <sub>I</sub>	input capacitance		3.5	3.5	pF
C <sub>PD</sub>	power dissipation capacitance per package	notes 1 and 2	59	61	pF

## Notes

1. C<sub>PD</sub> is used to determine the dynamic power dissipation (P<sub>D</sub> in μW):

$$P_D = C_{PD} \times V_{CC}^2 \times f_i + \sum (C_L \times V_{CC}^2 \times f_o) \text{ where:}$$

f<sub>i</sub> = input frequency in MHz

f<sub>o</sub> = output frequency in MHz

∑ (C<sub>L</sub> × V<sub>CC</sub><sup>2</sup> × f<sub>o</sub>) = sum of outputs

C<sub>L</sub> = output load capacitance in pF

V<sub>CC</sub> = supply voltage in V

2. For HC the condition is V<sub>I</sub> = GND to V<sub>CC</sub>  
For HCT the condition is V<sub>I</sub> = GND to V<sub>CC</sub> – 1.5 V

## ORDERING INFORMATION

See “74HC/HCT/HCU/HCMOS Logic Package Information”.

Binary up/down counter

74HC/HCT4516

PIN DESCRIPTION

PIN NO.	SYMBOL	NAME AND FUNCTION
1	PL	parallel load input (active HIGH)
4, 12, 13, 3	D <sub>0</sub> to D <sub>3</sub>	parallel inputs
5	$\overline{CE}$	count enable input (active LOW)
6, 11, 14, 2	Q <sub>0</sub> to Q <sub>3</sub>	parallel outputs
7	$\overline{TC}$	terminal count output (active LOW)
8	GND	ground (0 V)
9	MR	asynchronous master reset input (active HIGH)
10	UP/ $\overline{DN}$	up/down control input
15	CP	clock input (LOW-to-HIGH, edge-triggered)
16	V <sub>CC</sub>	positive supply voltage

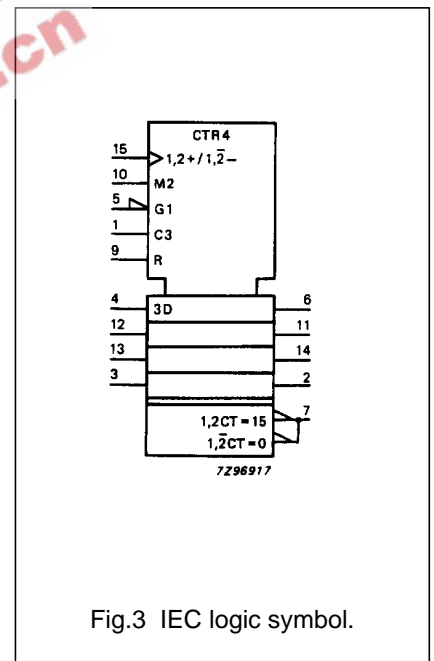
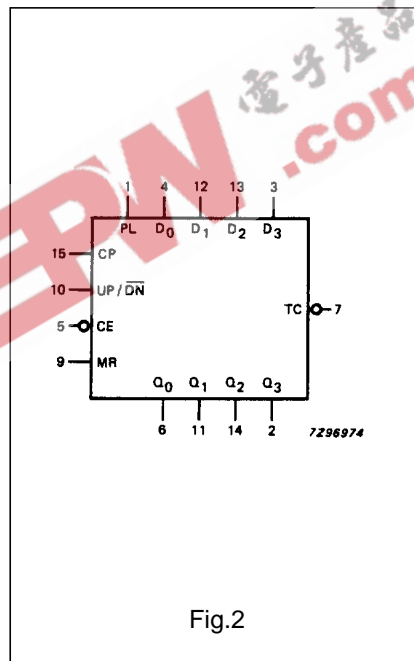
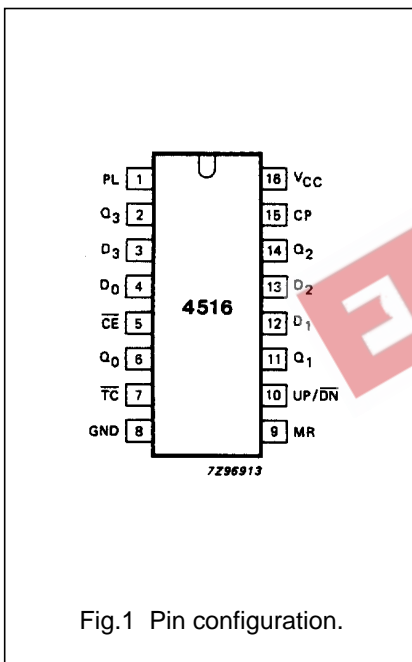

Binary up/down counter

74HC/HCT4516

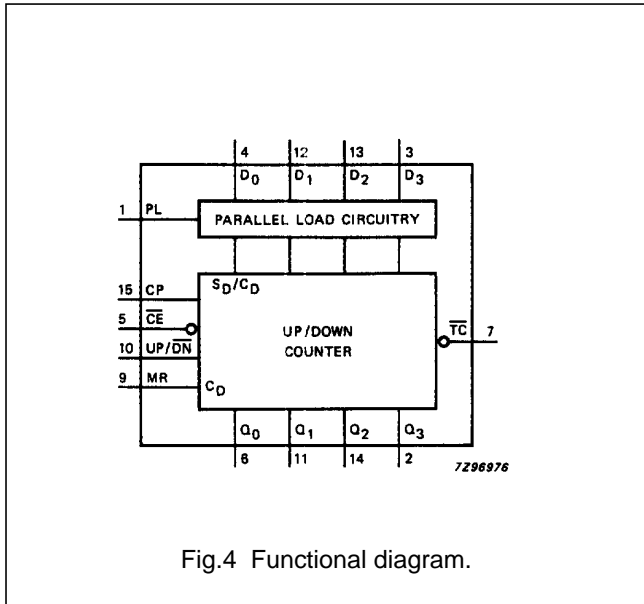

Fig.4 Functional diagram.

FUNCTION TABLE

MR	PL	UP/DN	CE	CP	MODE
L	H	X	X	X	parallel load
L	L	X	H	X	no change
L	L	L	L	↑	count down
L	L	H	L	↑	count up
H	X	X	X	X	reset

Notes

- 1. H = HIGH voltage level
- L = LOW voltage level
- X = don't care
- ↑ = LOW-to-HIGH clock transition

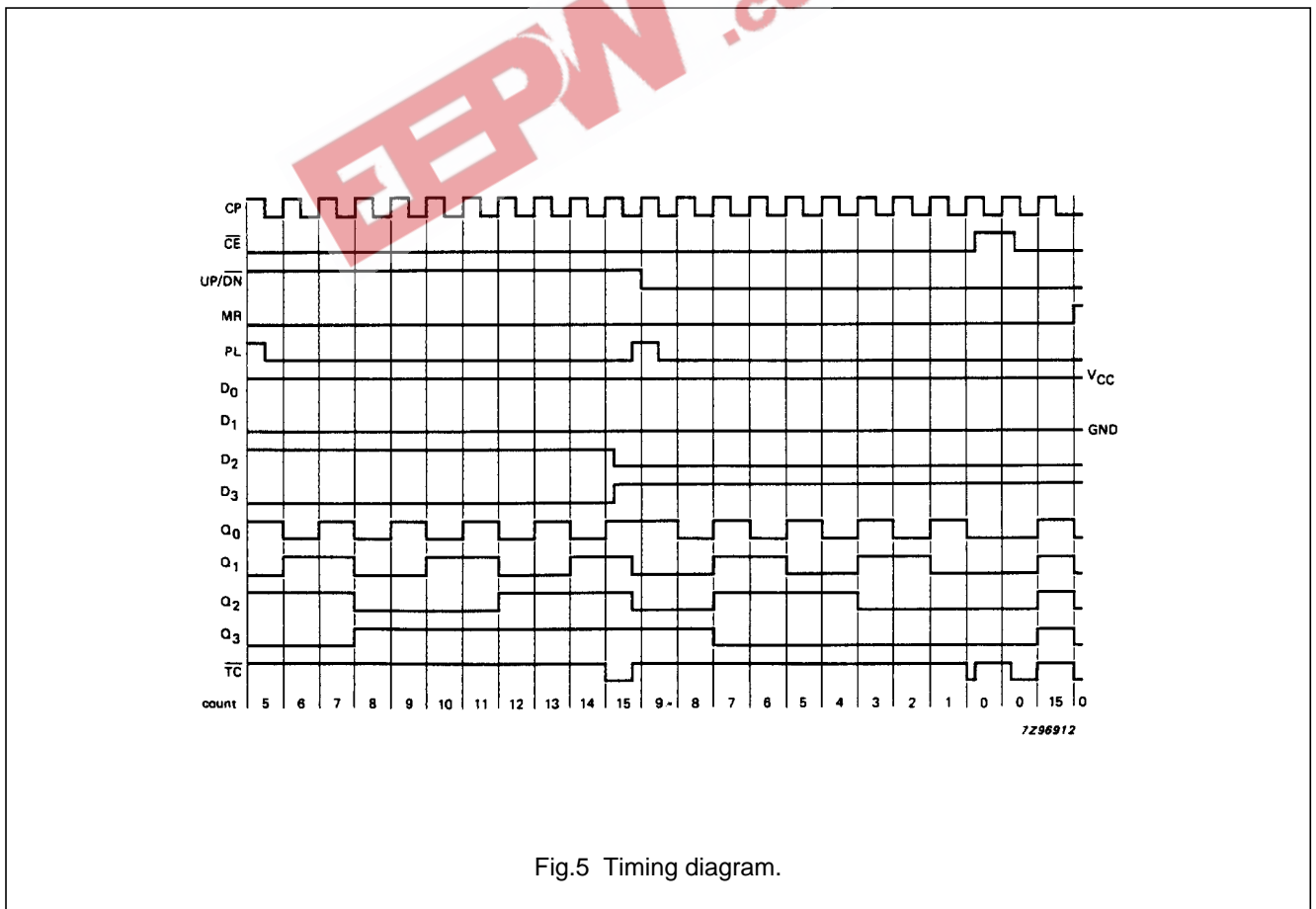

Fig.5 Timing diagram.

Binary up/down counter

74HC/HCT4516

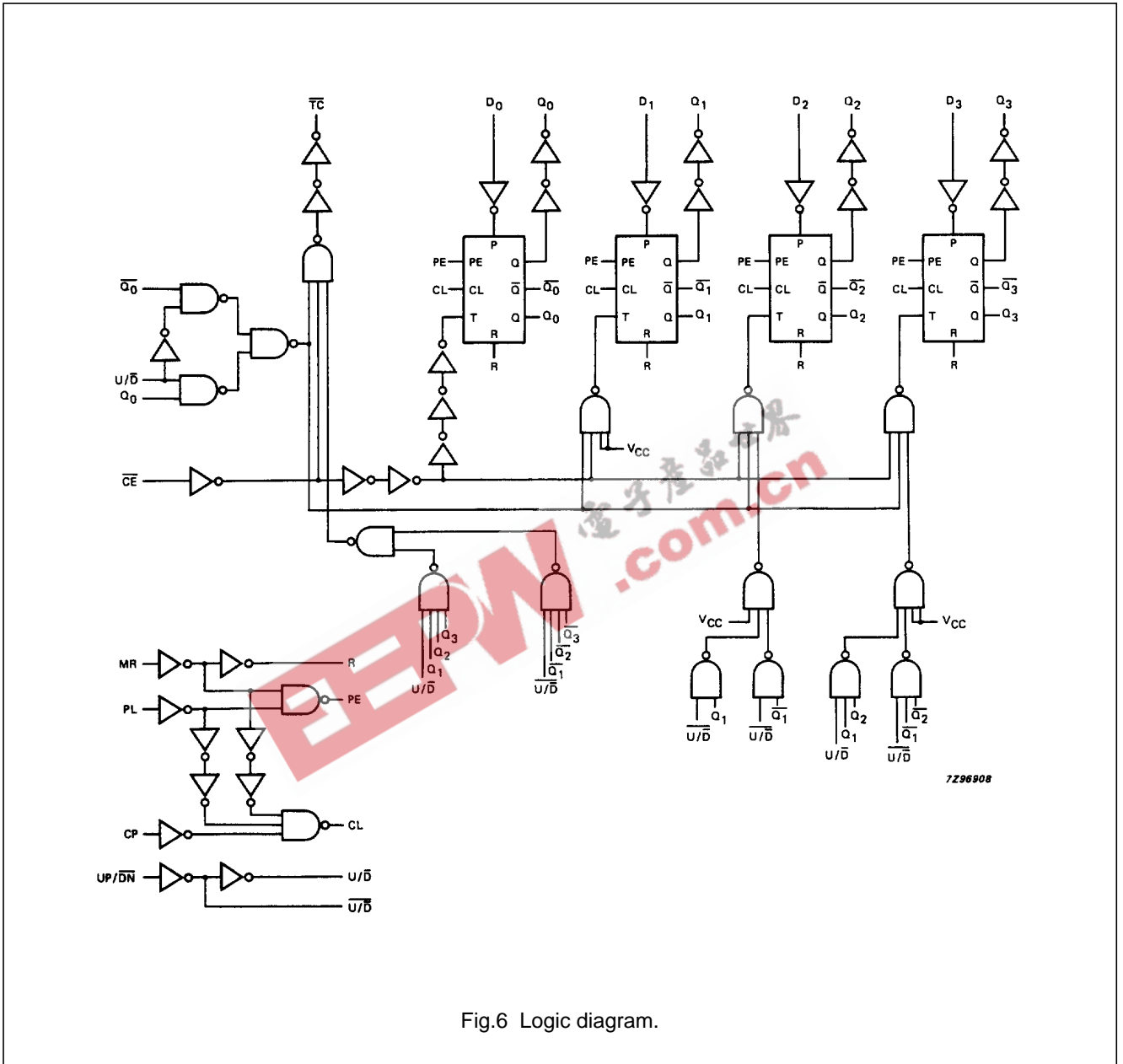

Fig.6 Logic diagram.

## Binary up/down counter

## 74HC/HCT4516

## DC CHARACTERISTICS FOR 74HC

For the DC characteristics see *"74HC/HCT/HCU/HCMOS Logic Family Specifications"*.

Output capability: standard

I<sub>CC</sub> category: MSI

## AC CHARACTERISTICS FOR 74HC

GND = 0 V; t<sub>r</sub> = t<sub>f</sub> = 6 ns; C<sub>L</sub> = 50 pF

SYMBOL	PARAMETER	T <sub>amb</sub> (°C)							UNIT	TEST CONDITIONS	
		74HC								V <sub>CC</sub> (V)	WAVEFORMS
		+25			-40 to+85		-40 to +125				
		min.	typ.	max.	min.	max.	min.	max.			
t <sub>PHL</sub> / t <sub>PLH</sub>	propagation delay CP to Q <sub>n</sub>		72 26 21	220 44 37		275 55 47		330 66 56	ns	2.0 4.5 6.0	Fig.7
t <sub>PHL</sub>	propagation delay MR to Q <sub>n</sub>		69 25 20	210 42 36		265 53 45		315 63 54	ns	2.0 4.5 6.0	Fig.10
t <sub>PLH</sub> / t <sub>PHL</sub>	propagation delay PL to Q <sub>n</sub>		83 30 24	250 50 43		315 63 54		375 75 64	ns	2.0 4.5 6.0	Fig.9
t <sub>PHL</sub> / t <sub>PLH</sub>	propagation delay CP to TC		74 27 22	260 52 44		325 65 55		395 78 66	ns	2.0 4.5 6.0	Fig.7
t <sub>PHL</sub> / t <sub>PLH</sub>	propagation delay CE to TC		36 13 10	125 25 21		155 31 26		190 38 32	ns	2.0 4.5 6.0	Fig.8
t <sub>PLH</sub>	propagation delay MR to TC		69 25 20	235 47 40		295 59 50		355 71 60	ns	2.0 4.5 6.0	Fig.10
t <sub>PLH</sub> / t <sub>PHL</sub>	propagation delay PL to TC		91 33 26	300 60 51		375 75 64		450 90 77	ns	2.0 4.5 6.0	Fig.9
t <sub>TLH</sub> / t <sub>THL</sub>	output transition time		19 7 6	75 15 13		95 19 16		110 22 19	ns	2.0 4.5 6.0	Fig.9
t <sub>w</sub>	clock pulse width CP, CE HIGH or LOW	80 16 14	25 9 7		100 20 17		120 24 20		ns	2.0 4.5 6.0	Fig.7
t <sub>w</sub>	parallel load pulse width HIGH	80 16 14	28 10 8		100 20 17		120 24 20		ns	2.0 4.5 6.0	Fig.10
t <sub>w</sub>	master reset pulse width HIGH	80 16 14	19 7 6		100 20 17		120 24 20		ns	2.0 4.5 6.0	Fig.10

Binary up/down counter

74HC/HCT4516

SYMBOL	PARAMETER	T <sub>amb</sub> (°C)						UNIT	TEST CONDITIONS		
		74HC							V <sub>CC</sub> (V)	WAVEFORMS	
		+25			-40 to+85		-40 to +125				
		min.	typ.	max.	min.	max.	min.				max.
t <sub>rem</sub>	removal time MR to CP	80 16 14	28 10 8		100 20 17		120 24 20	ns	2.0 4.5 6.0	Fig.10	
t <sub>rem</sub>	removal time PL to CP	80 16 14	25 9 7		100 20 17		120 24 20	ns	2.0 4.5 6.0	Fig.10	
t <sub>su</sub>	set-up time UP/DN to CP	100 20 17	30 11 9		125 25 21		150 30 26	ns	2.0 4.5 6.0	Fig.8	
t <sub>su</sub>	set-up time CE to CP	100 20 17	19 7 6		125 25 21		150 30 26	ns	2.0 4.5 6.0	Fig.8	
t <sub>su</sub>	set-up time D <sub>n</sub> to PL	100 20 17	17 6 5		125 25 21		150 30 26	ns	2.0 4.5 6.0	Fig.11	
t <sub>h</sub>	hold time CE to CP	5 5 5	0 0 0		5 5 5		5 5 5	ns	2.0 4.5 6.0	Fig.8	
t <sub>h</sub>	hold time D <sub>n</sub> to PL	3 3 3	-6 -2 -2		3 3 3		3 3 3	ns	2.0 4.5 6.0	Fig.11	
t <sub>h</sub>	hold time UP/DN to CP	0 0 0	-19 -7 -6		0 0 0		0 0 0	ns	2.0 4.5 6.0	Fig.8	
f <sub>max</sub>	maximum clock pulse frequency	6.0 30 35	16 49 58		4.8 24 28		4.0 20 24	MHz	2.0 4.5 6.0	Fig.7	

## Binary up/down counter

74HC/HCT4516

**DC CHARACTERISTICS FOR 74HCT**

For the DC characteristics see "*74HC/HCT/HCU/HCMOS Logic Family Specifications*".

Output capability: standard

I<sub>CC</sub> category: MSI

**Note to HCT types**

The value of additional quiescent supply current ( $\Delta I_{CC}$ ) for a unit load of 1 is given in the family specifications.

To determine  $\Delta I_{CC}$  per input, multiply this value by the unit load coefficient shown in the table below.

INPUT	UNIT LOAD COEFFICIENT
D <sub>n</sub>	0.75
PL, $\overline{CE}$	1.00
UP/ $\overline{DN}$	1.00
CP	1.25
MR	1.50

EEPW 电子产品世界  
.com.cn



## Binary up/down counter

## 74HC/HCT4516

## AC CHARACTERISTICS FOR 74HCT

GND = 0 V;  $t_r = t_f = 6$  ns;  $C_L = 50$  pF

SYMBOL	PARAMETER	$T_{amb}$ (°C)								UNIT	TEST CONDITIONS	
		74HCT									$V_{CC}$ (V)	WAVEFORMS
		+25			-40 to +85		-40 to +125					
		min.	typ.	max.	min.	max.	min.	max.				
$t_{PHL}/t_{PLH}$	propagation delay CP to $Q_n$		28	50		63		75	ns	4.5	Fig.7	
$t_{PHL}$	propagation delay MR to $Q_n$		24	42		53		63	ns	4.5	Fig.10	
$t_{PLH}/t_{PHL}$	propagation delay PL to $Q_n$		32	53		66		80	ns	4.5	Fig.9	
$t_{PHL}/t_{PLH}$	propagation delay CP to $\overline{TC}$		29	58		73		87	ns	4.5	Fig.7	
$t_{PHL}/t_{PLH}$	propagation delay $\overline{CE}$ to $\overline{TC}$		18	31		39		47	ns	4.5	Fig.8	
$t_{PLH}$	propagation delay MR to $\overline{TC}$		31	50		63		75	ns	4.5	Fig.10	
$t_{PLH}/t_{PHL}$	propagation delay PL to $\overline{TC}$		34	68		85		102	ns	4.5	Fig.9	
$t_{TLH}/t_{THL}$	output transition time		7	15		19		22	ns	4.5	Fig.9	
$t_W$	clock pulse width CP, $\overline{CE}$ HIGH or LOW	16	9		20		24		ns	4.5	Fig.7	
$t_W$	parallel load pulse width HIGH	16	8		20		24		ns	4.5	Fig.10	
$t_W$	master rest pulse width HIGH	20	5		25		30		ns	4.5	Fig.10	
$t_{rem}$	removal time MR to CP	23	14		29		35		ns	4.5	Fig.10	
$t_{rem}$	removal time PL to CP	17	10		21		26		ns	4.5	Fig.10	
$t_{su}$	set-up time UP/ $\overline{DN}$ to CP	20	11		25		30		ns	4.5	Fig.8	
$t_{su}$	set-up time $\overline{CE}$ to CP	20	9		25		30		ns	4.5	Fig.8	
$t_{su}$	set-up time $D_n$ to PL	20	9		25		30		ns	4.5	Fig.11	
$t_h$	hold time $\overline{CE}$ to CP	10	9		13		15		ns	4.5	Fig.8	

## Binary up/down counter

## 74HC/HCT4516

SYMBOL	PARAMETER	T <sub>amb</sub> (°C)							UNIT	TEST CONDITIONS	
		74HCT								V <sub>CC</sub> (V)	WAVEFORMS
		+25			-40 to +85		-40 to +125				
		min.	typ.	max.	min.	max.	min.	max.			
t <sub>h</sub>	hold time D <sub>n</sub> to PL	5	-6		5		5		ns	4.5	Fig.11
t <sub>h</sub>	hold time UP/DN to CP	0	-5		0		0		ns	4.5	Fig.8
f <sub>max</sub>	maximum clock pulse frequency	30	52		24		20		MHz	4.5	Fig.7

EEPW 电子产品世界  
.com.cn

Binary up/down counter

74HC/HCT4516

AC WAVEFORMS

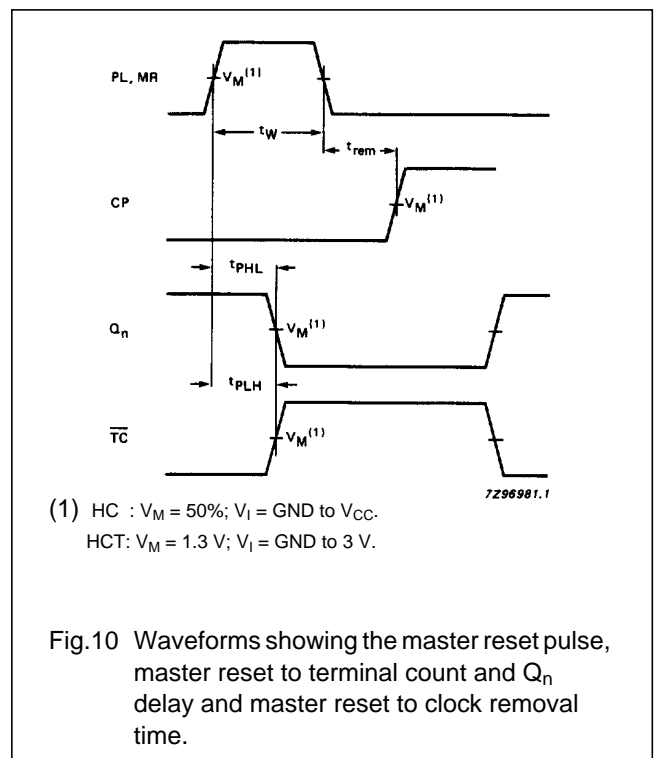
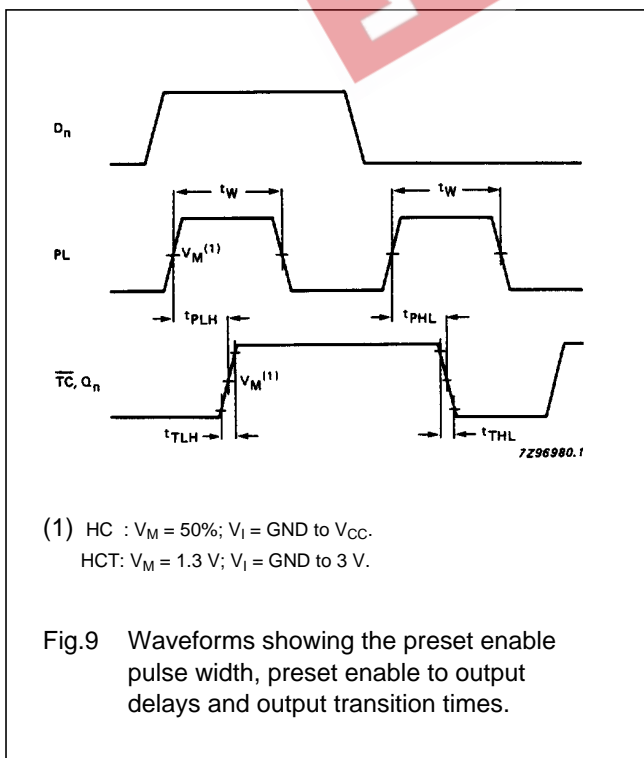
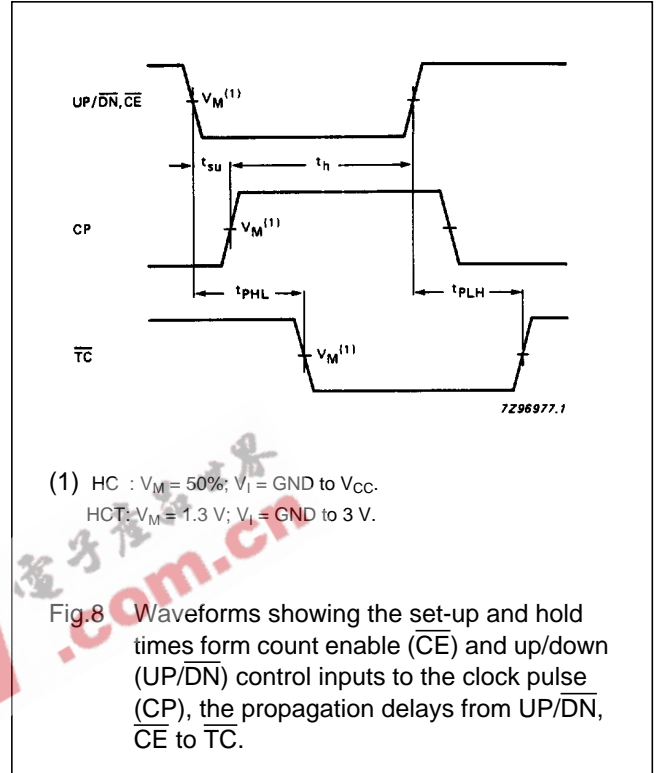
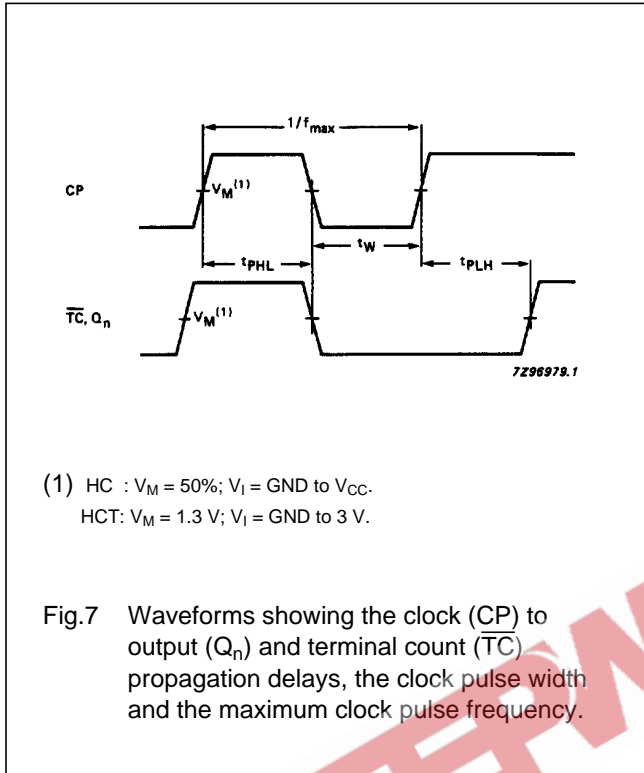

Binary up/down counter

74HC/HCT4516

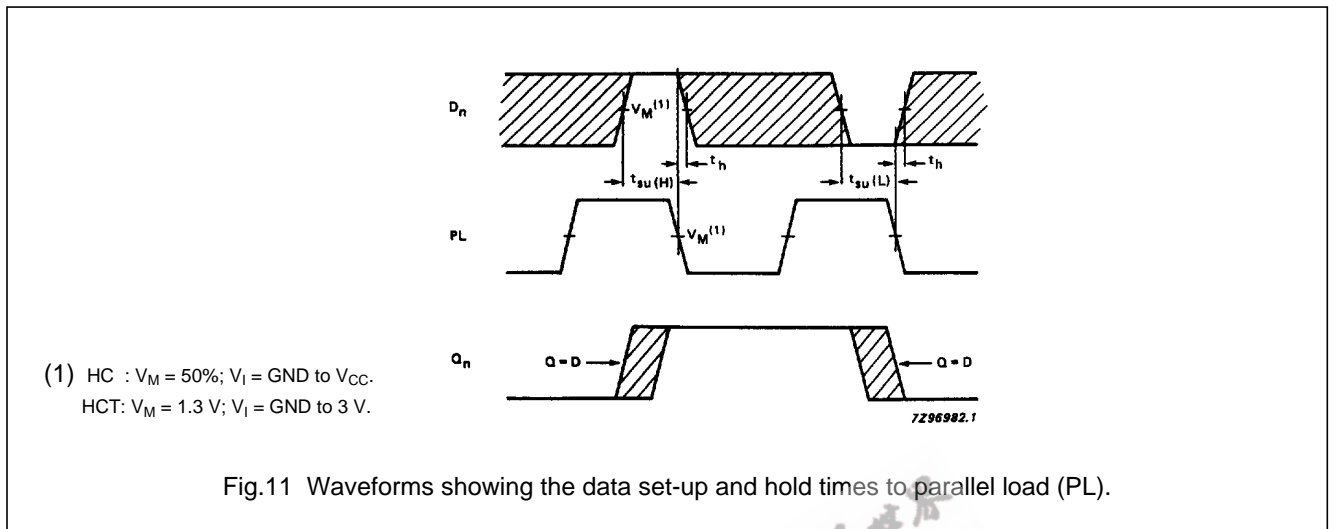

Fig.11 Waveforms showing the data set-up and hold times to parallel load (PL).

EEPW.com.cn 电子产品世界

Binary up/down counter

74HC/HCT4516

APPLICATION INFORMATION

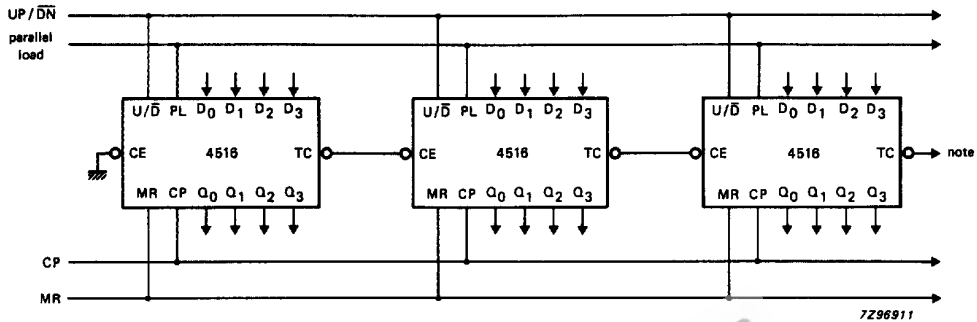

Terminal count ( $\overline{TC}$ ) lines at the 2nd, 3rd, etc. Stages may have a negative-going glitch pulse resulting from differential delays of different 4516s. These negative-going glitches do not affect proper 4516 operation. However, if the terminal count signals are used to trigger other edge-sensitive logic devices, such as flip-flops or counters, the terminal count signals should be gated with the clock signal using a 2-input OR gate such as HC/HCT32.

Fig.12 Cascading counter packages (parallel clocking).

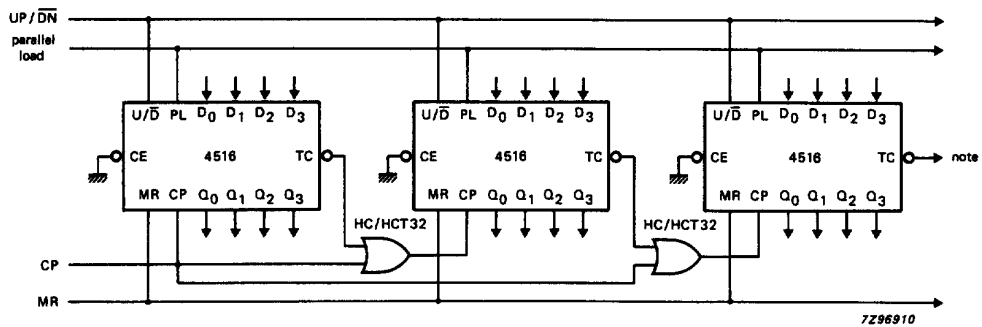

Ripple clocking mode: the UP/DN control can be changed at any count. The only restriction on changing the UP/DN control is that the clock input to the first counting stage must be "HIGH". For cascading counters operating in a fixed up-count or down-count mode, the OR gates are not required between stages and TC is connected directly to the CP input of the next stage with CE grounded.

Fig.13 Cascading counter packages (ripple clocking).

Binary up/down counter

74HC/HCT4516

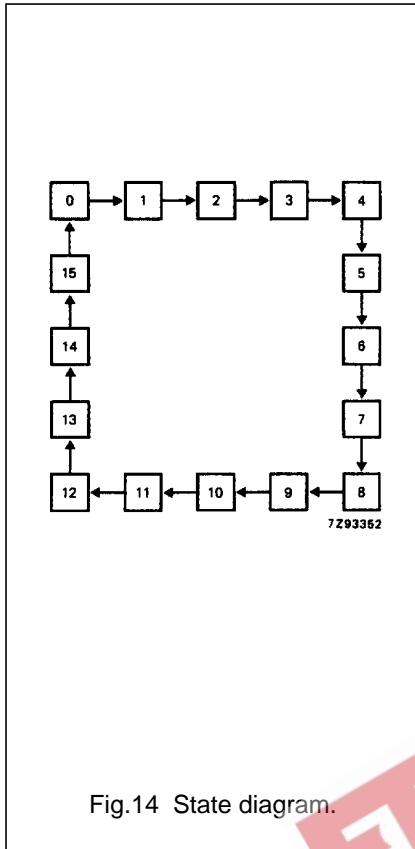

Fig.14 State diagram.

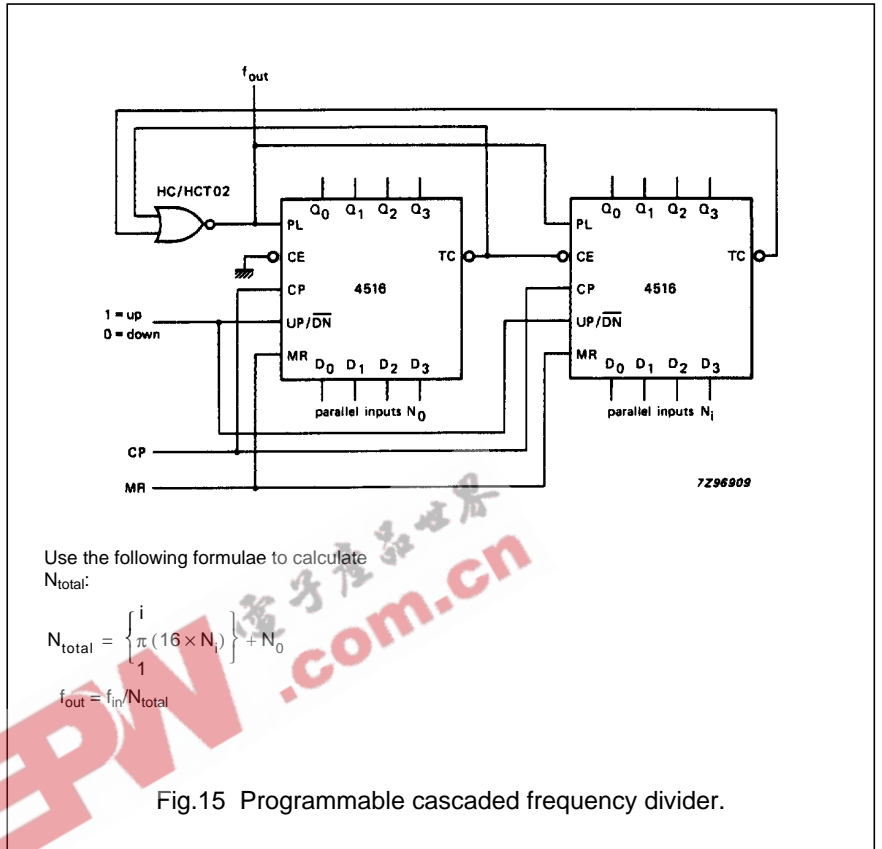

Fig.15 Programmable cascaded frequency divider.

PACKAGE OUTLINES

See "74HC/HCT/HCU/HCMOS Logic Package Outlines".

parallel inputs				count-up	count-down
D <sub>3</sub>	D <sub>2</sub>	D <sub>1</sub>	D <sub>0</sub>	n	n
0	0	0	0	15	(1)
0	0	0	1	14	1
0	0	1	0	13	2
0	0	1	1	12	3
0	1	0	0	11	4
0	1	0	1	10	5
0	1	1	0	9	6
0	1	1	1	8	7
1	0	0	0	7	8
1	0	0	1	6	9
1	0	1	0	5	10
1	0	1	1	4	11
1	1	0	0	3	12
1	1	0	1	2	13
1	1	1	0	1	14
1	1	1	1	(1)	15

Note

- 1. no count;  $f_{out}$  is HIGH.