

Document No.	853-1492
ECN No.	00730
Date of Issue	October 17, 1990
Status	Product Specification
ACL Products	

74AC/ACT11190

Asynchronous presettable synchronous decade up/down counter with single clock

FEATURES

- Synchronous, reversible counting
- Positive edge-triggered clock
- BCD/decade
- Asynchronous Parallel Load capability
- Output capability: $\pm 24\text{mA}$
- CMOS (AC) and TTL (ACT) voltage level inputs
- 50Ω incident wave switching
- Center-pin V_{CC} and ground configuration to minimize high-speed switching noise
- I_{CC} category: MSI

DESCRIPTION

The 74AC/ACT11190 high-performance CMOS devices combine very high speed and high output drive comparable to the most advanced TTL families.

The 74AC/ACT11190 is an asynchronously presettable up/down BCD decade counter. It contains four master/slave flip-flops with internal gating and steering logic to provide asynchronous preset and synchronous count-up and count-down operation.

(continued)

QUICK REFERENCE DATA

SYMBOL	PARAMETER	CONDITIONS $T_{amb} = 25^\circ\text{C}; \text{GND} = 0\text{V};$ $V_{CC} = 5.0\text{V}$	TYPICAL		UNIT
			AC	ACT	
t_{PLH}/t_{PHL}	Propagation delay CP to Q_n ($\overline{PE} = \text{High}$)	$C_L = 50\text{pF}$	5.2	7.3	ns
C_{PD}	Power dissipation capacitance ¹	$f = 1\text{MHz}; C_L = 50\text{pF}$	68	70	pF
C_{IN}	Input capacitance	$V_I = 0\text{V}$ or V_{CC}	4.0	4.0	pF
I_{LATCH}	Latch-up current	Per JEDEC J40.2 Standard 17	500	500	mA
f_{MAX}	Maximum clock frequency; $CP \rightarrow Q_n$	$C_L = 50\text{pF}$	150	120	MHz

Note:

1. C_{PD} is used to determine the dynamic power dissipation (P_D in μW):

$$P_D = C_{PD} \times V_{CC}^2 \times f_I + \sum (C_L \times V_{CC}^2 \times f_O) \text{ where:}$$

f_I = input frequency in MHz, C_L = output load capacitance in pF,

f_O = output frequency in MHz, V_{CC} = supply voltage in V,

$\sum (C_L \times V_{CC}^2 \times f_O)$ = sum of outputs

ORDERING INFORMATION

PACKAGES	TEMPERATURE RANGE	ORDER CODE
20-pin plastic DIP (300mil-wide)	-40°C to +85°C	74AC11190N 74ACT11190N
20-pin plastic SOL (300mil-wide)	-40°C to +85°C	74AC11190D 74ACT11190D

PIN CONFIGURATION

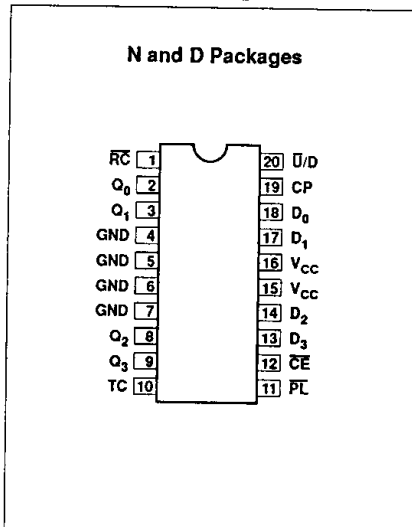

LOGIC SYMBOL

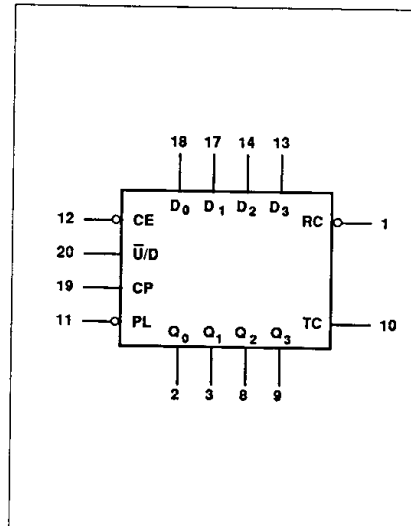

LOGIC SYMBOL (IEEE/IEC)

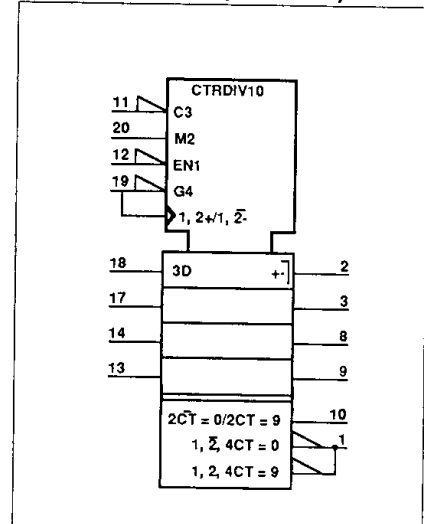

Asynchronous presetable synchronous decade up/down counter with single clock

74AC/ACT11190

Asynchronous Parallel Load capability permits the counter to be preset to any desired number. Information present on the parallel Data inputs ($D_0 - D_3$) is loaded into the counter and appears on the outputs when the Parallel Load (PL) input is Low. As indicated in the Mode Select Table, this operation overrides the counting function.

Counting is inhibited by a High level on the Count Enable (\overline{CE}) input.

Overflow/underflow indications are provided by two types of outputs, the Terminal Count (TC) and Ripple Clock (RC). The TC output is normally Low and goes High when: 1) the count reaches zero in the count-down mode or 2) reaches "9" in the Count-up mode. The TC output will remain High until a state change occurs, either by counting or presetting, or until $\overline{U/D}$ is changed. TC output should not be used as a clock signal because it is subject to decoding spikes. The TC signal is used internally to enable the RC output.

When TC is High and \overline{CE} is Low, the RC follows the Clock Pulse. The RC output essentially duplicates the Low clock pulse width, although delayed in time by two gate delays. The 74AC/ACT11190 simplifies the design of multistage counters, as indicated in Figures 1a and 1b.

In Figure 1a, each RC output is used as the Clock input for the next higher stage. When the Clock input source has limited drive capability this configuration is particularly advantageous, since the clock source drives only the first stage. It is only necessary to inhibit the first stage to prevent counting in all stages, since a High signal on \overline{CE} inhibits the RC output pulse as indicated in the Mode Select Table. The timing skew between state changes in the first and last stages is represented by the cumulative delay of the clock as it ripples through the preceding stages. This is a disadvantage of the configuration in some applications.

Figure 1b shows a method of causing state changes to occur simultaneously in all stages. The RC outputs propagate the carry/borrow signals in ripple fashion and all Clock inputs are driven in parallel. The Low state duration of the clock in this configuration must be long enough to allow the negative-going edge of the carry/borrow signal to ripple through to the last stage before the clock goes High. Since the RC output of any package goes High shortly after its CP input goes High, there is no such restriction on the High state duration of the clock.

In Figure 1c, the configuration shown avoids ripple delays and their associated restrictions. Combining the TC signals from all the preceding stages forms the \overline{CE} input signal for a given stage. An enable signal must be included in each carry gate in order to inhibit counting. The TC output of a given stage is not affected by its own \overline{CE} , therefore, the simple inhibit scheme of Figure 1a and 1b does not apply.

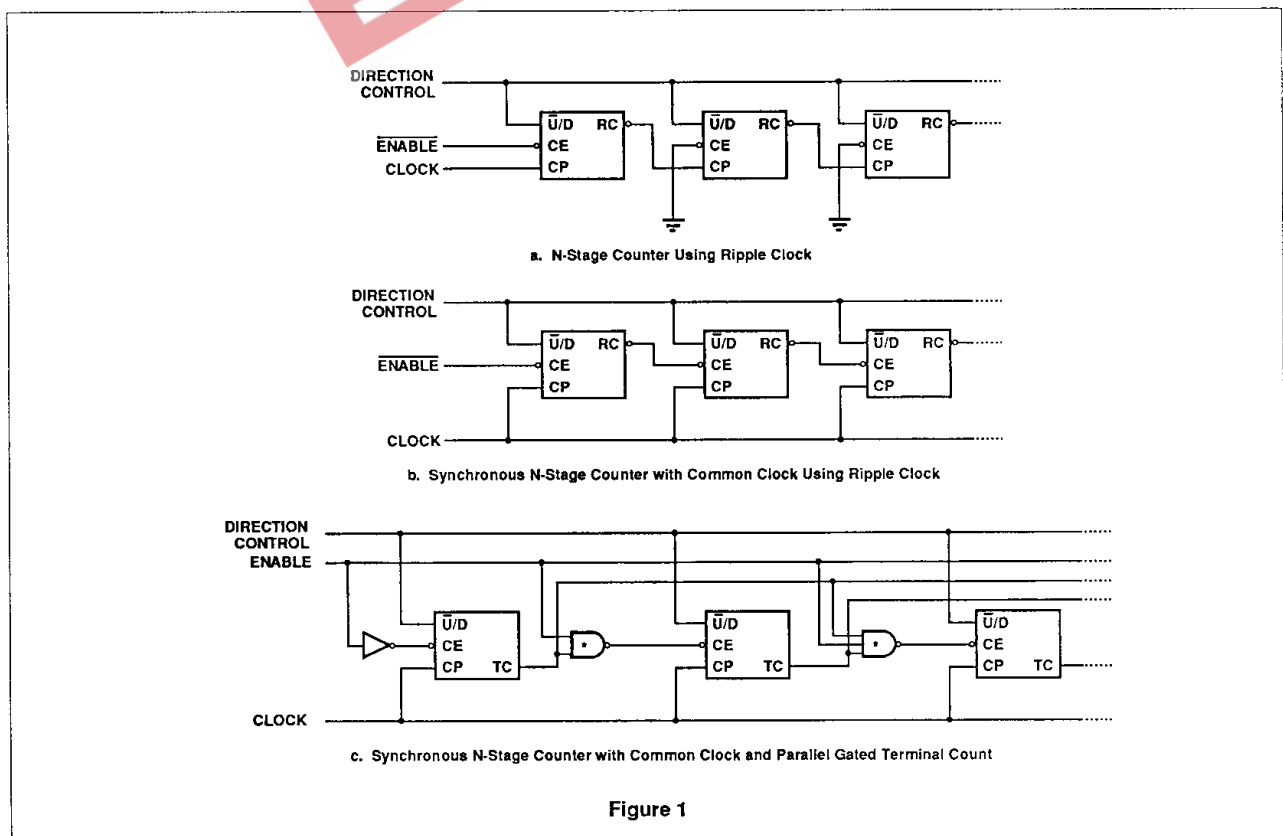

Figure 1

Asynchronous presettable synchronous decade up/down counter with single clock

74AC/ACT11190

PIN DESCRIPTION

PIN NUMBER	SYMBOL	NAME AND FUNCTION
20	\bar{U}/D	Up/down count control input
12	\bar{CE}	Count enable input (active-Low)
18, 17, 14, 13	$D_0 - D_3$	Data inputs
19	CP	Clock pulse input (active rising edge)
11	\bar{PL}	Asynchronous load input (active-Low)
2, 3, 8, 9	$Q_0 - Q_3$	Counter outputs
1	\bar{RC}	Ripple clock output (active-Low)
10	TC	Terminal count output
4, 5, 6, 7	GND	Ground (0V)
15, 16	V_{CC}	Positive supply voltage

MODE SELECT — FUNCTION TABLE

OPERATING MODE	INPUTS					OUTPUTS
	\bar{PL}	\bar{U}/D	\bar{CE}	CP	D_n	Q_n
Parallel load	L	X	X	X	L	L
	L	X	X	X	H	H
Count up	H	L	I	↑	X	count up
Count down	H	H	I	↑	X	count down
Hold (do nothing)	H	X	H	X	X	no change

TC AND \bar{RC} FUNCTION TABLE

INPUTS			TERMINAL COUNT STATE				OUTPUTS	
\bar{U}/D	\bar{CE}	CP	Q_0	Q_1	Q_2	Q_3	TC	\bar{RC}
H	H	X	H	X	X	H	L	H
L	H	X	H	L	L	H	H	H
L	L	⌋	H	L	L	H	H	⌋
L	H	X	L	L	L	L	L	H
H	H	X	L	L	L	L	H	H
H	L	⌋	L	L	L	L	H	⌋

H = High voltage level

L = Low voltage level

h = High voltage level one setup time prior to the Low-to-High clock transition

l = Low voltage level one setup time prior to the Low-to-High clock transition

X = Don't care

↑ = Low-to-High clock transition

⌋ = Low pulse

Asynchronous presetable synchronous decade up/down counter with single clock

74AC/ACT11190

LOGIC DIAGRAM

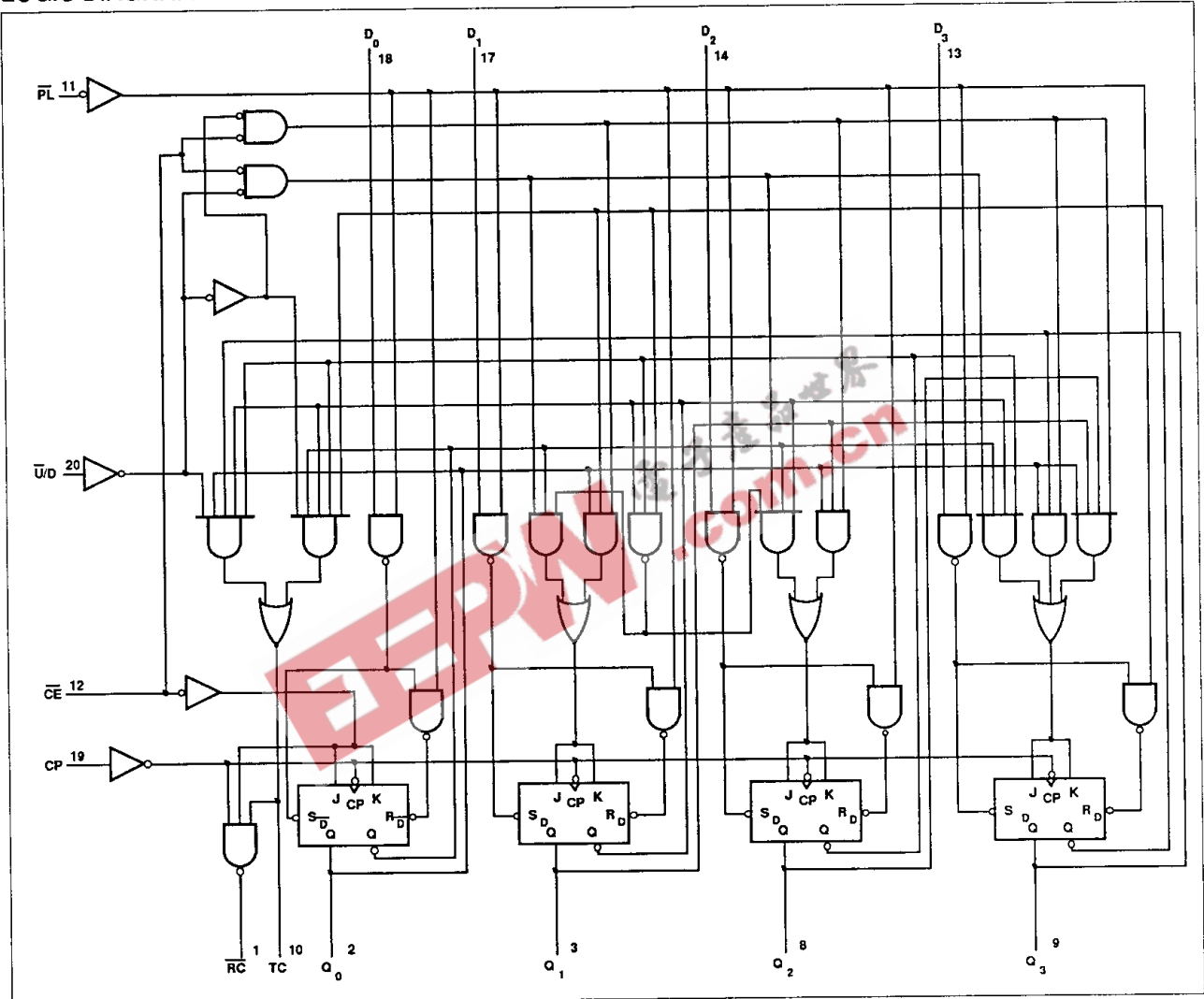

STATE DIAGRAM

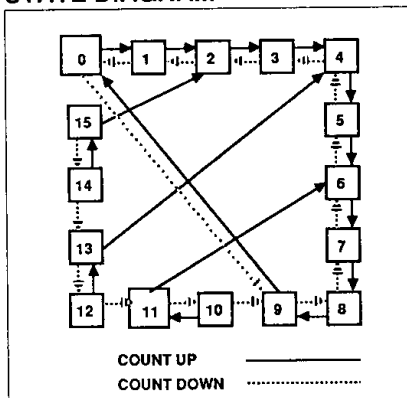

Asynchronous presetable synchronous decade up/down counter with single clock

74AC/ACT11190

RECOMMENDED OPERATING CONDITIONS

SYMBOL	PARAMETER	74AC11190			74ACT11190			UNIT
		Min	Nom	Max	Min	Nom	Max	
V_{CC}	DC supply voltage	3.0 ¹	5.0	5.5	4.5	5.0	5.5	V
V_I	Input voltage	0		V_{CC}	0		V_{CC}	V
V_O	Output voltage	0		V_{CC}	0		V_{CC}	V
$\Delta t/\Delta v$	Input transition rise or fall rate	0		10	0		10	ns/V
T_{amb}	Operating free-air temperature range	-40		+85	-40		+85	°C

NOTE:

1. No electrical or switching characteristics are specified at $V_{CC} < 3V$. Operation between 2V and 3V is not recommended, but within that range, a device output will maintain a previously established logic state.

ABSOLUTE MAXIMUM RATINGS¹

SYMBOL	PARAMETER	TEST CONDITIONS	RATING	UNIT
V_{CC}	DC supply voltage		-0.5 TO +7.0	V
I_{IK} or V_I	DC input diode current ²	$V_I < 0$	-20	mA
	DC input voltage	$V_I > V_{CC}$	20	
I_{OK} or V_O	DC output diode current ²	$V_O < 0$	-50	mA
		$V_O > V_{CC}$	50	
	DC output voltage		-0.5 to $V_{CC} + 0.5$	V
I_O	DC output source or sink current per output pin	$V_O = 0$ to V_{CC}	± 50	mA
I_{CC} or I_{GND}	DC V_{CC} current		± 150	mA
	DC ground current		± 150	
T_{STG}	Storage temperature		-65 to 150	°C
P_{TOT}	Power dissipation per package	Above 70°C; derate linearly by 8mW/K	500	mW
	Power dissipation per package Plastic surface mount (SO)	Above 70°C; derate linearly by 8mW/K	400	mW

NOTES:

1. Stresses beyond those listed may cause permanent damage to the device. These are stress ratings only and functional operation of the device at these or any other conditions beyond those indicated under "recommended operating conditions" is not implied. Exposure to absolute-maximum-rated conditions for extended periods may affect device reliability.
2. The input and output voltage ratings may be exceeded if the input and output current ratings are observed.

Asynchronous presettable synchronous decade up/down counter with single clock

74AC/ACT11190

DC ELECTRICAL CHARACTERISTICS

SYMBOL	PARAMETER	TEST CONDITIONS	V _{CC}	74AC11190				74ACT11190				UNIT	
				T _{amb} = +25°C		T _{amb} = -40°C to +85°C		T _{amb} = +25°C		T _{amb} = -40°C to +85°C			
				Min	Max	Min	Max	Min	Max	Min	Max		
V _{IH}	High-level input voltage		3.0	2.10		2.10						V	
			4.5	3.15		3.15		2.0		2.0			
			5.5	3.85		3.85		2.0		2.0			
V _{IL}	Low-level input voltage		3.0		0.90		0.90					V	
			4.5		1.35		1.35		0.8		0.8		
			5.5		1.65		1.65		0.8		0.8		
V _{OH}	High-level output voltage	V _I = V _{IL} or V _{IH}	I _{OH} = -50μA	3.0	2.9		2.9					V	
				4.5	4.4		4.4		4.4		4.4		
				5.5	5.4		5.4		5.4		5.4		
			I _{OH} = -4mA	3.0	2.58		2.48						
				4.5	3.94		3.8		3.94		3.8		
				5.5	4.94		4.8		4.94		4.8		
I _{OH} = -75mA ¹	5.5			3.85				3.85					
V _{OL}	Low-level output voltage	V _I = V _{IL} or V _{IH}	I _{OL} = 50μA	3.0		0.1		0.1				V	
				4.5		0.1		0.1		0.1			0.1
				5.5		0.1		0.1		0.1			0.1
			I _{OL} = 12mA	3.0		0.36		0.44					
				4.5		0.36		0.44		0.36			0.44
			I _{OL} = 24mA	4.5		0.36		0.44		0.36			0.44
				5.5		0.36		0.44		0.36			0.44
I _{OL} = 75mA ¹	5.5				1.65				1.65				
I _I	Input leakage current	V _I = V _{CC} or GND	5.5		±0.1		±1.0		±0.1		±1.0	μA	
I _{CC}	Quiescent supply current	V _I = V _{CC} or GND, I _O = 0mA	5.5		8.0		80		8.0		80	μA	
ΔI _{CC}	Supply current, TTL inputs High ²	One input at 3.4V, other inputs at V _{CC} or GND	5.5						0.9		1.0	mA	

NOTES:

- Not more than one output should be tested at a time, and the duration of the test should not exceed 10ms.
- This is the increase in supply current for each input that is at one of the specified TTL voltage levels rather than 0V or V_{CC}.

Asynchronous presettable synchronous decade up/down counter with single clock

74AC/ACT11190

AC ELECTRICAL CHARACTERISTICS AT 3.3V ±0.3V

SYMBOL	PARAMETER		WAVEFORM	74AC11190					UNIT
				T _{amb} = +25°C			T _{amb} = -40°C to +85°C		
				Min	Typ	Max	Min	Max	
f _{MAX}	Maximum clock frequency	CP to Q _n	1	65	95		65		MHz
		CP to \overline{RC} , TC		60	85		60		MHz
t _{PLH} t _{PHL}	Propagation delay CP to Q _n		1	2.3 2.8	7.6 7.2	10.0 9.8	2.3 2.8	11.1 11.0	ns
t _{PLH} t _{PHL}	Propagation delay CP to TC			1	4.3 3.5	9.0 9.8	12.0 12.3	4.3 3.5	14.2 15.1
t _{PLH} t _{PHL}	Propagation delay CP to \overline{RC}		2		3.0 3.0	7.6 7.4	10.5 9.6	3.0 3.0	12.4 11.2
t _{PLH} t _{PHL}	Propagation delay \overline{CE} to \overline{RC}			2	2.9 3.0	6.9 6.8	9.4 8.6	2.9 3.0	11.0 10.1
t _{PLH} t _{PHL}	Propagation delay $\overline{U/D}$ to \overline{RC}		2		4.8 4.5	11.0 10.6	14.3 13.6	4.8 4.5	16.8 16.2
t _{PLH} t _{PHL}	Propagation delay $\overline{U/D}$ to TC			4	3.3 3.9	8.4 8.7	11.8 11.2	3.3 3.9	14.1 13.1
t _{PLH} t _{PHL}	Propagation delay D _n to Q _n		3		3.9 4.0	9.6 9.0	12.8 11.4	3.9 4.0	15.0 13.5
t _{PLH} t _{PHL}	Propagation delay D _n to TC			3, 4	5.0 4.9	13.1 11.9	18.3 16.3	5.0 4.9	21.8 19.4
t _{PLH} t _{PHL}	Propagation delay D _n to \overline{RC}		3, 4		5.6 6.2	14.0 15.3	19.2 20.2	5.6 6.2	22.7 24.3
t _{PLH} t _{PHL}	Propagation delay \overline{PL} to Q _n			5	3.4 3.5	10.2 9.0	13.6 11.6	3.4 3.5	15.8 13.7
t _{PLH} t _{PHL}	Propagation delay \overline{PL} to TC		5		5.4 5.2	13.8 12.2	17.9 15.9	5.4 5.2	21.3 19.0
t _{PLH} t _{PHL}	Propagation delay \overline{PL} to \overline{RC}			5	5.9 6.6	14.2 15.8	18.8 19.7	5.9 6.6	23.0 23.7
t _S	Setup time, High or Low D _n to \overline{PL}		6		3.5			3.5	
t _H	Hold time, High or Low D _n to \overline{PL}			6	0.5			0.5	
t _S	Setup time, High or Low \overline{CE} to CP		6		11.5			11.5	
t _H	Hold time, High or Low \overline{CE} to CP			6	0.0			0.0	
t _S	Setup time, High or Low $\overline{U/D}$ to CP		6		12.0			12.0	
t _H	Hold time, High or Low $\overline{U/D}$ to CP			6	0.0			0.0	
t _w	\overline{PL} pulse width, Low		5		4.5			4.5	
t _w	CP pulse width, High or Low			1	8.3			8.3	
t _{REC}	Recover time, \overline{PL} to CP		5		2.5			2.5	

Asynchronous presettable synchronous decade up/down counter with single clock

74AC/ACT11190

AC ELECTRICAL CHARACTERISTICS AT 5.0V ±0.5V

SYMBOL	PARAMETER		WAVEFORM	74AC11190					UNIT
				T _{amb} = +25°C			T _{amb} = -40°C to +85°C		
				Min	Typ	Max	Min	Max	
f _{MAX}	Maximum clock frequency	CP to Q _n	1	120	150		120		MHz
		CP to \overline{RC} , TC		75	100		75		MHz
t _{PLH} t _{PHL}	Propagation delay CP to Q _n		1	1.8 2.1	4.9 5.4	7.3 7.7	1.8 2.1	8.1 8.8	ns
t _{PLH} t _{PHL}	Propagation delay CP to TC		1	3.0 3.3	6.0 6.7	8.6 9.1	3.0 3.3	9.7 10.4	ns
t _{PLH} t _{PHL}	Propagation delay CP to \overline{RC}		2	2.1 2.6	5.1 5.2	7.6 7.2	2.1 2.6	8.6 8.0	ns
t _{PLH} t _{PHL}	Propagation delay CE to RC		2	2.5 2.8	4.9 5.1	7.0 6.9	2.5 2.8	7.8 7.7	ns
t _{PLH} t _{PHL}	Propagation delay $\overline{U/D}$ to \overline{RC}		2	4.1 4.0	7.3 7.2	10.1 10.1	4.1 4.0	11.2 11.3	ns
t _{PLH} t _{PHL}	Propagation delay $\overline{U/D}$ to TC		4	2.9 3.4	5.6 6.2	8.7 8.3	2.9 3.4	9.7 9.4	ns
t _{PLH} t _{PHL}	Propagation delay D _n to Q _n		3	3.0 3.1	6.3 6.3	8.1 8.6	3.0 3.1	10.1 9.6	ns
t _{PLH} t _{PHL}	Propagation delay D _n to TC		3, 4	4.3 4.1	8.3 8.0	12.4 11.4	4.3 4.1	14.0 13.3	ns
t _{PLH} t _{PHL}	Propagation delay D _n to \overline{RC}		3, 4	4.8 5.2	9.0 9.8	13.2 13.9	4.0 5.2	14.8 15.6	ns
t _{PLH} t _{PHL}	Propagation delay \overline{PL} to Q _n		5	3.1 2.9	6.4 6.2	9.5 8.8	3.1 2.9	10.4 9.9	ns
t _{PLH} t _{PHL}	Propagation delay \overline{PL} to TC		5	4.9 4.4	8.8 8.2	12.3 11.5	4.9 4.4	13.8 12.9	ns
t _{PLH} t _{PHL}	Propagation delay \overline{PL} to \overline{RC}		5	5.3 5.8	9.1 10.1	12.8 13.6	5.3 5.8	14.4 15.3	ns
t _S	Setup time, High or Low D _n to \overline{PL}		6	2.5			2.5		ns
t _H	Hold time, High or Low D _n to \overline{PL}		6	0.5			0.5		ns
t _S	Setup time, High or Low \overline{CE} to CP		6	7.5			7.5		ns
t _H	Hold time, High or Low \overline{CE} to CP		6	0.0			0.0		ns
t _S	Setup time, High or Low $\overline{U/D}$ to CP		6	8.0			8.0		ns
t _H	Hold time, High or Low $\overline{U/D}$ to CP		6	0.0			0.0		ns
t _w	\overline{PL} pulse width, Low		5	3.5			3.5		ns
t _w	CP pulse width, High or Low		1	5.5			5.5		ns
t _{REC}	Recover time, \overline{PL} to CP		5	2.0			2.0		ns

Asynchronous presettable synchronous decade up/down counter with single clock

74AC/ACT11190

AC ELECTRICAL CHARACTERISTICS AT 5.0V ±0.5V

SYMBOL	PARAMETER		WAVEFORM	74ACT11190					UNIT
				T _{amb} = +25°C			T _{amb} = -40°C to +85°C		
				Min	Typ	Max	Min	Max	
f _{MAX}	Maximum clock frequency	CP to Q _n	1	85	120		85		MHz
		CP to \overline{RC} , TC		65	90		65		MHz
t _{PLH} t _{PHL}	Propagation delay CP to Q _n	1	3.7 4.2	7.0 7.6	9.1 9.7	3.7 4.2	10.0 11.0	ns	
t _{PLH} t _{PHL}	Propagation delay CP to TC		4.8 5.4	8.3 9.1	10.7 11.5	4.8 5.4	11.8 12.7	ns	
t _{PLH} t _{PHL}	Propagation delay CP to \overline{RC}	2	4.2 3.6	7.7 6.9	10.1 9.7	4.2 3.6	11.0 10.5	ns	
t _{PLH} t _{PHL}	Propagation delay \overline{CE} to \overline{RC}	2	3.9 3.0	6.6 6.1	8.9 8.4	3.9 3.0	9.7 9.2	ns	
t _{PLH} t _{PHL}	Propagation delay $\overline{U/D}$ to \overline{RC}	2	4.9 4.5	8.7 8.6	11.8 11.6	4.9 4.5	12.9 13.0	ns	
t _{PLH} t _{PHL}	Propagation delay $\overline{U/D}$ to TC	4	3.5 4.1	7.0 7.5	10.2 10.0	3.5 4.1	11.5 11.3	ns	
t _{PLH} t _{PHL}	Propagation delay D _n to Q _n	3	4.6 4.0	7.9 7.3	10.2 10.3	4.6 4.0	11.4 11.6	ns	
t _{PLH} t _{PHL}	Propagation delay D _n to TC	3, 4	5.1 4.9	9.7 9.6	13.7 13.2	5.1 4.9	15.2 14.6	ns	
t _{PLH} t _{PHL}	Propagation delay D _n to \overline{RC}	3, 4	5.7 6.4	10.6 11.3	14.7 15.0	5.7 6.4	16.2 16.7	ns	
t _{PLH} t _{PHL}	Propagation delay \overline{PL} to Q _n	5	4.1 4.1	7.6 7.6	10.7 10.5	4.1 4.1	11.8 11.8	ns	
t _{PLH} t _{PHL}	Propagation delay \overline{PL} to TC	5	5.4 5.0	9.9 9.5	13.7 13.0	5.4 5.0	15.2 14.6	ns	
t _{PLH} t _{PHL}	Propagation delay \overline{PL} to \overline{RC}	5	5.9 6.6	10.4 11.5	14.6 15.1	5.9 6.6	16.4 16.8	ns	
t _s	Setup time, High or Low D _n to \overline{PL}	6	2.5			2.5		ns	
t _h	Hold time, High or Low D _n to \overline{PL}	6	1.5			1.5		ns	
t _s	Setup time, High or Low \overline{CE} to CP	6	7.0			7.0		ns	
t _h	Hold time, High or Low \overline{CE} to CP	6	1.5			1.5		ns	
t _s	Setup time, High or Low $\overline{U/D}$ to CP	6	7.5			7.5		ns	
t _h	Hold time, High or Low $\overline{U/D}$ to CP	6	0.0			0.0		ns	
t _w	\overline{PL} pulse width, Low	5	4.0			4.0		ns	
t _w	CP pulse width, High or Low	1	7.7			7.7		ns	
t _{REC}	Recover time, \overline{PL} to CP	5	2.0			2.0		ns	

Asynchronous presettable synchronous decade up/down counter with single clock

74AC/ACT11190

AC WAVEFORMS

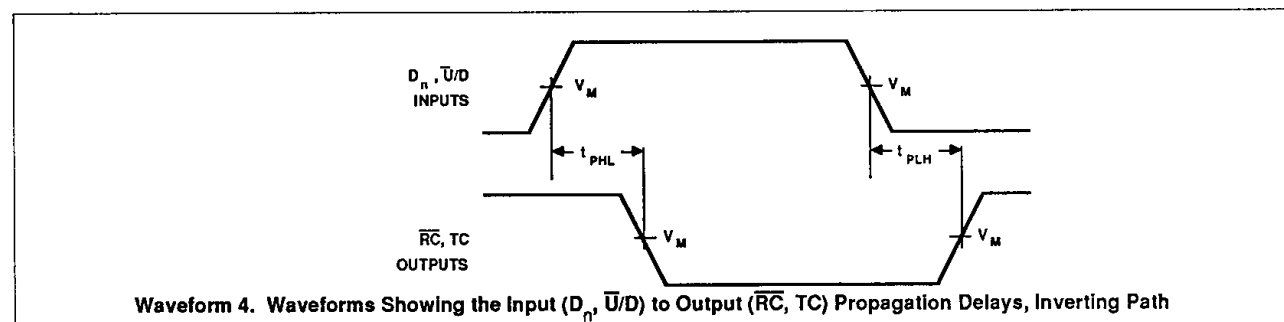
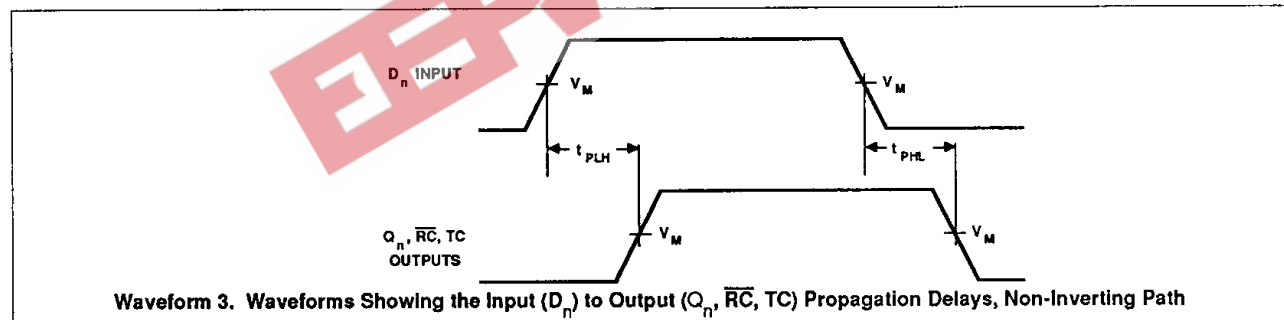
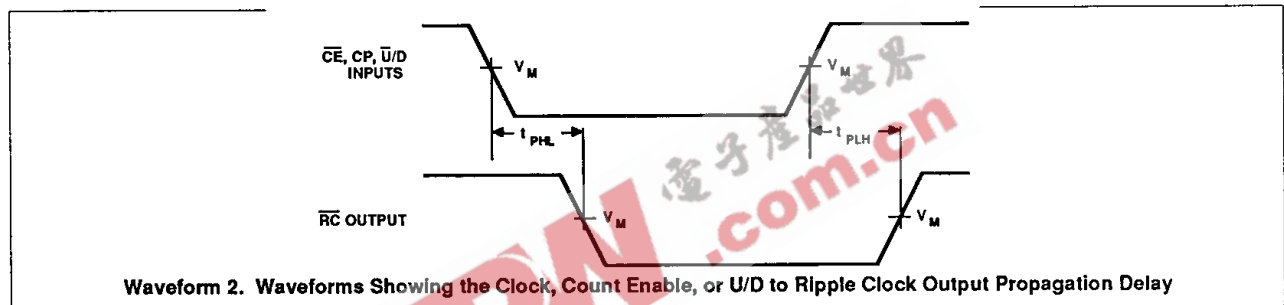
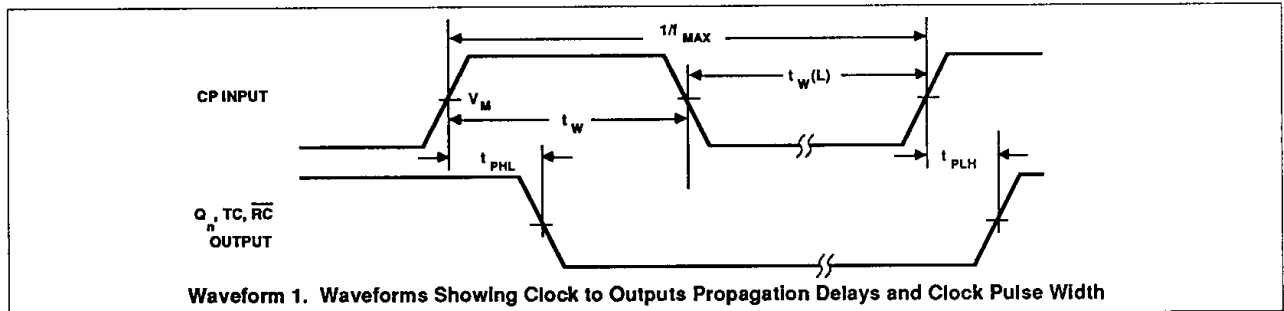

Asynchronous presettable synchronous decade up/down counter with single clock

74AC/ACT11190

AC WAVEFORMS (Continued)

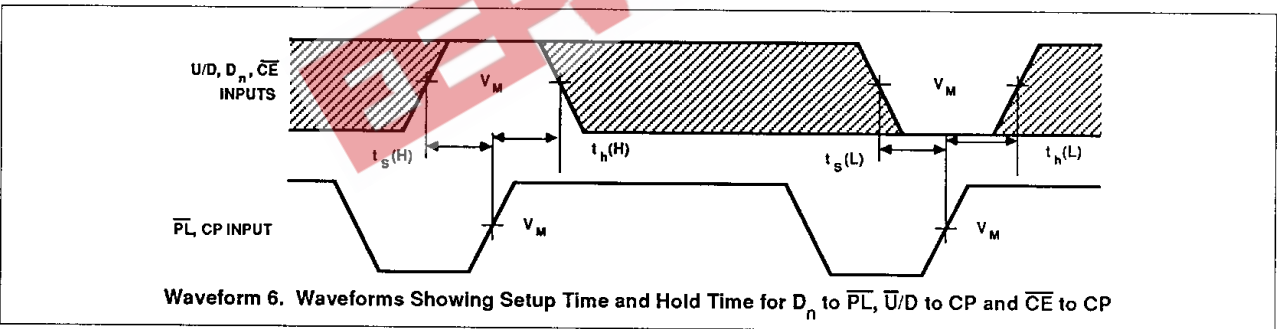
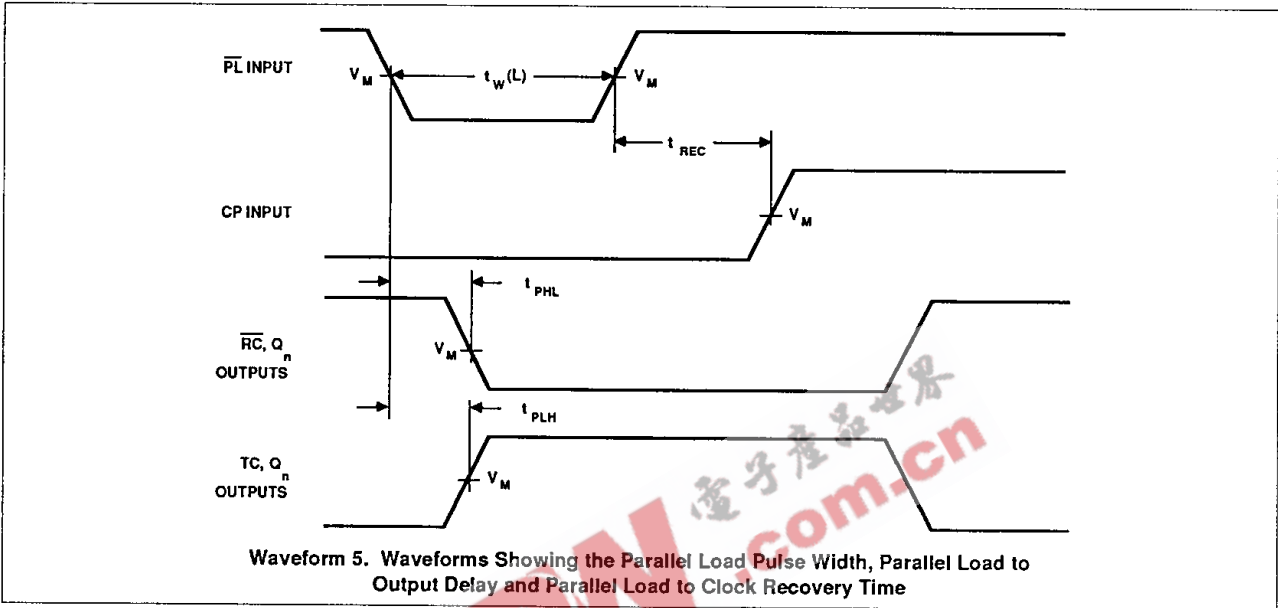

WAVEFORM CONDITIONS

	INPUTS	OUTPUTS
AC	$V_{IN} = GND \text{ to } V_{CC}$ $V_M = 50\% V_{CC}$	$V_{OUT} = V_{OL} \text{ to } V_{OH}$
ACT	$V_{IN} = GND \text{ to } 3.0V$ $V_M = 1.5V$	$V_M = 50\% V_{CC}$

Asynchronous presettable synchronous decade up/down counter with single clock

74AC/ACT11190

TEST CIRCUIT

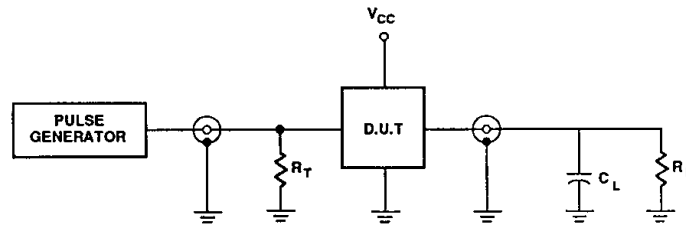

Test Circuit

DEFINITIONS

C_L = Load capacitance, 50pF; includes jig and probe capacitance

R_L = Load resistor, 500 Ω

R_T = Termination resistance should be equal to Z_{OUT} of pulse generators

Input pulses: PRR \leq 10MHz

$t_r = t_f = 3ns$