

SN74LS147 SN74LS148

10-Line-to-4-Line and 8-Line-to-3-Line Priority Encoders

The SN74LS147 and the SN74LS148 are Priority Encoders. They provide priority decoding of the inputs to ensure that only the highest order data line is encoded. Both devices have data inputs and outputs which are active at the low logic level.

The LS147 encodes nine data lines to four-line (8-4-2-1) BCD. The implied decimal zero condition does not require an input condition because zero is encoded when all nine data lines are at a high logic level.

The LS148 encodes eight data lines to three-line (4-2-1) binary (octal). By providing cascading circuitry (Enable Input EI and Enable Output EO) octal expansion is allowed without needing external circuitry.

GUARANTEED OPERATING RANGES

Symbol	Parameter	Min	Typ	Max	Unit
V _{CC}	Supply Voltage	4.75	5.0	5.25	V
T _A	Operating Ambient Temperature Range	0	25	70	°C
I _{OH}	Output Current – High			-0.4	mA
I _{OL}	Output Current – Low			8.0	mA



ON Semiconductor
Formerly a Division of Motorola
<http://onsemi.com>

**LOW
POWER
SCHOTTKY**

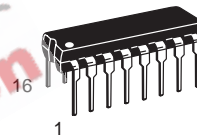

**PLASTIC
N SUFFIX
CASE 648**

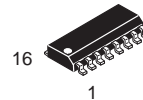

**SOIC
D SUFFIX
CASE 751B**

ORDERING INFORMATION

Device	Package	Shipping
SN74LS147N	16 Pin DIP	2000 Units/Box
SN74LS147D	16 Pin	2500/Tape & Reel
SN74LS148N	16 Pin DIP	2000 Units/Box
SN74LS148D	16 Pin	2500/Tape & Reel

SN74LS147 SN74LS148

SN74LS147
(TOP VIEW)

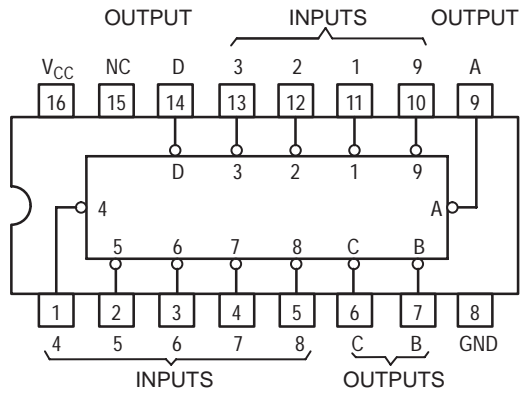

SN74LS148
(TOP VIEW)

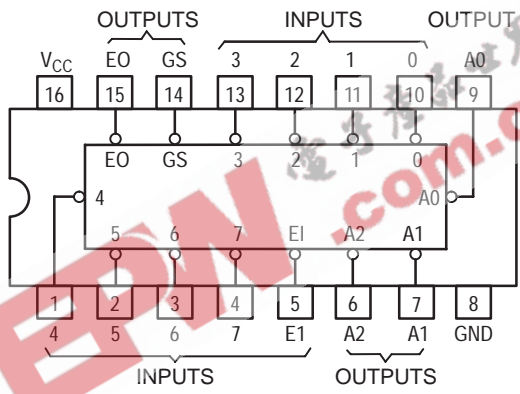

SN74LS147 SN74LS148

**SN74LS147
FUNCTION TABLE**

INPUTS									OUTPUTS			
1	2	3	4	5	6	7	8	9	D	C	B	A
H	H	H	H	H	H	H	H	H	H	H	H	H
X	X	X	X	X	X	X	X	L	L	H	H	L
X	X	X	X	X	X	X	L	H	L	H	H	H
X	X	X	X	X	X	L	H	H	H	L	L	L
X	X	X	X	X	L	H	H	H	H	L	L	H
X	X	X	L	H	H	H	H	H	H	L	H	L
X	X	L	H	H	H	H	H	H	H	H	L	L
X	L	H	H	H	H	H	H	H	H	H	L	H
L	H	H	H	H	H	H	H	H	H	H	H	L

**SN74LS148
FUNCTION TABLE**

INPUTS								OUTPUTS					
EI	0	1	2	3	4	5	6	7	A2	A1	A0	GS	EO
H	X	X	X	X	X	X	X	X	H	H	H	H	H
L	H	H	H	H	H	H	H	H	H	H	H	H	L
L	X	X	X	X	X	X	X	L	L	L	L	L	H
L	X	X	X	X	X	X	L	H	L	L	H	L	H
L	X	X	X	X	X	L	H	H	L	H	L	L	H
L	X	X	X	L	H	H	H	H	L	H	H	L	H
L	X	X	L	H	H	H	H	H	H	L	L	L	H
L	X	L	H	H	H	H	H	H	H	H	L	L	H
L	L	H	H	H	H	H	H	H	H	H	H	L	H

H = HIGH Logic Level, L = LOW Logic Level, X = Irrelevant

FUNCTIONAL BLOCK DIAGRAMS

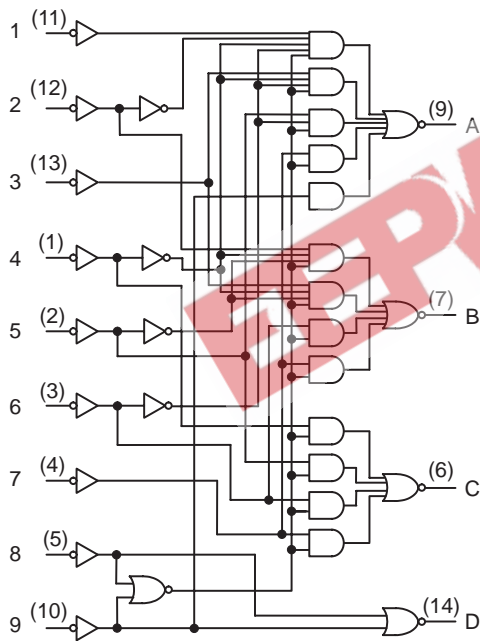

SN74LS147

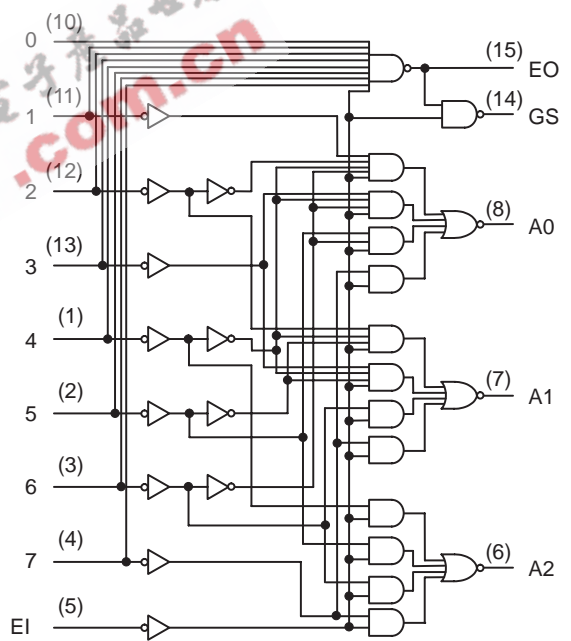

SN74LS148

SN74LS147 SN74LS148

DC CHARACTERISTICS OVER OPERATING TEMPERATURE RANGE (unless otherwise specified)

Symbol	Parameter	Limits			Unit	Test Conditions
		Min	Typ	Max		
V_{IH}	Input HIGH Voltage	2.0			V	Guaranteed Input HIGH Voltage for All Inputs
V_{IL}	Input LOW Voltage			0.8	V	Guaranteed Input LOW Voltage for All Inputs
V_{IK}	Input Clamp Diode Voltage		-0.65	-1.5	V	$V_{CC} = \text{MIN}$, $I_{IN} = -18 \text{ mA}$
V_{OH}	Output HIGH Voltage	2.7	3.5		V	$V_{CC} = \text{MIN}$, $I_{OH} = \text{MAX}$, $V_{IN} = V_{IH}$ or V_{IL} per Truth Table
V_{OL}	Output LOW Voltage		0.25	0.4	V	$I_{OL} = 4.0 \text{ mA}$
			0.35	0.5	V	$I_{OL} = 8.0 \text{ mA}$
I_{IH}	Input HIGH Current All Others Inputs 1-7 (LS148)			20 40	μA	$V_{CC} = \text{MAX}$, $V_{IN} = 2.7 \text{ V}$
	All Others Inputs 1-7 (LS148)			0.1 0.2	mA	$V_{CC} = \text{MAX}$, $V_{IN} = 7.0 \text{ V}$
I_{IL}	Input LOW Current All Others Inputs 1-7 (LS148)			-0.4 -0.8	mA	$V_{CC} = \text{MAX}$, $V_{IN} = 0.4 \text{ V}$
I_{OS}	Short Circuit Current (Note 1)	-20		-100	mA	$V_{CC} = \text{MAX}$
I_{CCH}	Power Supply Current Output HIGH			17	mA	$V_{CC} = \text{MAX}$, All Inputs = 4.5 V
I_{CCL}	Output LOW			20	mA	$V_{CC} = \text{MAX}$, Inputs 7 & E1 = GND All Other Inputs = 4.5 V

Note 1: Not more than one output should be shorted at a time, nor for more than 1 second.

SN74LS147 SN74LS148

AC CHARACTERISTICS ($V_{CC} = 5.0\text{ V}$, $T_A = 25^\circ\text{C}$)

SN74LS147

Symbol	From (Input)	To (Output)	Waveform	Limits			Unit	Test Conditions
				Min	Typ	Max		
t_{PLH}	Any	Any	In-phase output		12	18	ns	$C_L = 15\text{ pF}$, $R_L = 2.0\text{ k}\Omega$
t_{PHL}					12	18		
t_{PLH}	Any	Any	Out-of-phase output		21	33	ns	
t_{PHL}					15	23		

SN74LS148

Symbol	From (Input)	To (Output)	Waveform	Limits			Unit	Test Conditions	
				Min	Typ	Max			
t_{PLH}	1 thru 7	A0, A1, or A2	In-phase output		14	18	ns	$C_L = 15\text{ pF}$, $R_L = 2.0\text{ k}\Omega$	
t_{PHL}					15	25			
t_{PLH}	1 thru 7	A0, A1, or A2	Out-of-phase output		20	36	ns		
t_{PHL}					16	29			
t_{PLH}	0 thru 7	EO	Out-of-phase output		7.0	18	ns		
t_{PHL}					25	40			
t_{PLH}	0 thru 7	GS	In-phase output		35	55	ns		
t_{PHL}					9.0	21			
t_{PLH}	EI	A0, A1, or A2	In-phase output		16	25	ns		
t_{PHL}					12	25			
t_{PLH}	EI	GS	In-phase output		12	17	ns		
t_{PHL}					14	36			
t_{PLH}	EI	EO	In-phase output		12	21	ns		
t_{PHL}					28	40			
					30	45			(LS148)

SN74LS147 SN74LS148

PACKAGE DIMENSIONS

N SUFFIX
 PLASTIC PACKAGE
 CASE 648-08
 ISSUE R

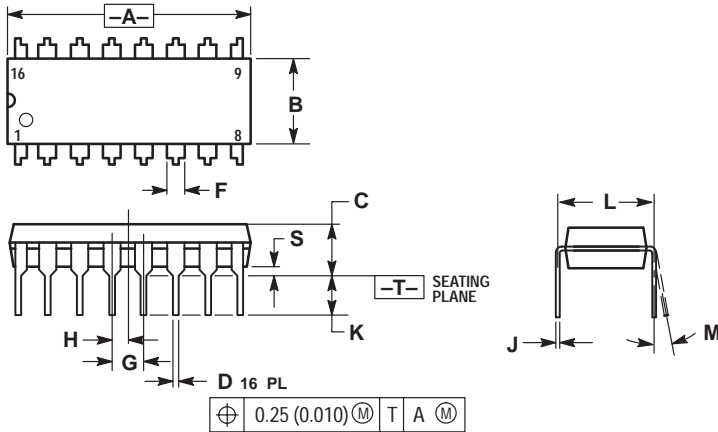

- NOTES:
1. DIMENSIONING AND TOLERANCING PER ANSI Y14.5M, 1982.
 2. CONTROLLING DIMENSION: INCH.
 3. DIMENSION L TO CENTER OF LEADS WHEN FORMED PARALLEL.
 4. DIMENSION B DOES NOT INCLUDE MOLD FLASH.
 5. ROUNDED CORNERS OPTIONAL.

DIM	INCHES		MILLIMETERS	
	MIN	MAX	MIN	MAX
A	0.740	0.770	18.80	19.55
B	0.250	0.270	6.35	6.85
C	0.145	0.175	3.69	4.44
D	0.015	0.021	0.39	0.53
F	0.040	0.70	1.02	1.77
G	0.100 BSC		2.54 BSC	
H	0.050 BSC		1.27 BSC	
J	0.008	0.015	0.21	0.38
K	0.110	0.130	2.80	3.30
L	0.295	0.305	7.50	7.74
M	0°	10°	0°	10°
S	0.020	0.040	0.51	1.01



SN74LS147 SN74LS148

PACKAGE DIMENSIONS

D SUFFIX
 PLASTIC SOIC PACKAGE
 CASE 751B-05
 ISSUE J

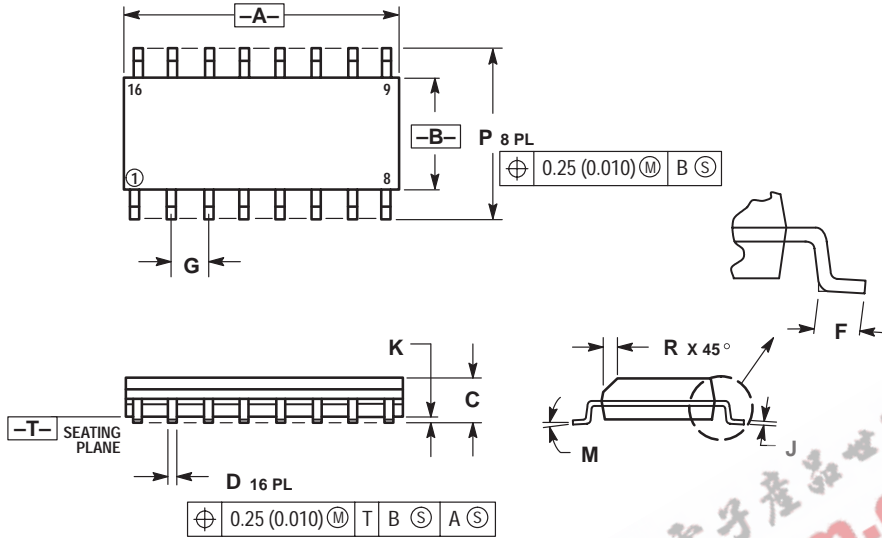

NOTES:

1. DIMENSIONING AND TOLERANCING PER ANSI Y14.5M, 1982.
2. CONTROLLING DIMENSION: MILLIMETER.
3. DIMENSIONS A AND B DO NOT INCLUDE MOLD PROTRUSION.
4. MAXIMUM MOLD PROTRUSION 0.15 (0.006) PER SIDE.
5. DIMENSION D DOES NOT INCLUDE DAMBAR PROTRUSION. ALLOWABLE DAMBAR PROTRUSION SHALL BE 0.127 (0.005) TOTAL IN EXCESS OF THE D DIMENSION AT MAXIMUM MATERIAL CONDITION.

DIM	MILLIMETERS		INCHES	
	MIN	MAX	MIN	MAX
A	9.80	10.00	0.386	0.393
B	3.80	4.00	0.150	0.157
C	1.35	1.75	0.054	0.068
D	0.35	0.49	0.014	0.019
F	0.40	1.25	0.016	0.049
G	1.27	BSC	0.050	BSC
J	0.19	0.25	0.008	0.009
K	0.10	0.25	0.004	0.009
M	0°	7°	0°	7°
P	5.80	6.20	0.229	0.244
R	0.25	0.50	0.010	0.019

SN74LS147 SN74LS148

EEPW 电子产品世界 .com.cn

ON Semiconductor and  are trademarks of Semiconductor Components Industries, LLC (SCILLC). SCILLC reserves the right to make changes without further notice to any products herein. SCILLC makes no warranty, representation or guarantee regarding the suitability of its products for any particular purpose, nor does SCILLC assume any liability arising out of the application or use of any product or circuit, and specifically disclaims any and all liability, including without limitation special, consequential or incidental damages. "Typical" parameters which may be provided in SCILLC data sheets and/or specifications can and do vary in different applications and actual performance may vary over time. All operating parameters, including "Typicals" must be validated for each customer application by customer's technical experts. SCILLC does not convey any license under its patent rights nor the rights of others. SCILLC products are not designed, intended, or authorized for use as components in systems intended for surgical implant into the body, or other applications intended to support or sustain life, or for any other application in which the failure of the SCILLC product could create a situation where personal injury or death may occur. Should Buyer purchase or use SCILLC products for any such unintended or unauthorized application, Buyer shall indemnify and hold SCILLC and its officers, employees, subsidiaries, affiliates, and distributors harmless against all claims, costs, damages, and expenses, and reasonable attorney fees arising out of, directly or indirectly, any claim of personal injury or death associated with such unintended or unauthorized use, even if such claim alleges that SCILLC was negligent regarding the design or manufacture of the part. SCILLC is an Equal Opportunity/Affirmative Action Employer.

PUBLICATION ORDERING INFORMATION

North America Literature Fulfillment:

Literature Distribution Center for ON Semiconductor
P.O. Box 5163, Denver, Colorado 80217 USA
Phone: 303-675-2175 or 800-344-3860 Toll Free USA/Canada
Fax: 303-675-2176 or 800-344-3867 Toll Free USA/Canada
Email: ONlit@hibbertco.com

N. American Technical Support: 800-282-9855 Toll Free USA/Canada

EUROPE: LDC for ON Semiconductor – European Support

German Phone: (+1) 303-308-7140 (M-F 2:30pm to 5:00pm Munich Time)
Email: ONlit-german@hibbertco.com

French Phone: (+1) 303-308-7141 (M-F 2:30pm to 5:00pm Toulouse Time)
Email: ONlit-french@hibbertco.com

English Phone: (+1) 303-308-7142 (M-F 1:30pm to 5:00pm UK Time)
Email: ONlit@hibbertco.com

ASIA/PACIFIC: LDC for ON Semiconductor – Asia Support

Phone: 303-675-2121 (Tue-Fri 9:00am to 1:00pm, Hong Kong Time)
Toll Free from Hong Kong 800-4422-3781
Email: ONlit-asia@hibbertco.com

JAPAN: ON Semiconductor, Japan Customer Focus Center

4-32-1 Nishi-Gotanda, Shinagawa-ku, Tokyo, Japan 141-8549
Phone: 81-3-5487-8345
Email: r14153@onsemi.com

Fax Response Line: 303-675-2167

800-344-3810 Toll Free USA/Canada

ON Semiconductor Website: <http://onsemi.com>

For additional information, please contact your local Sales Representative.