

DATA SHEET

EEPW 电子产品世界
.com.cn

74ABTL3205

10-bit BTL transceiver with registers

Product specification

1995 Jun 16

10-bit BTL transceiver with registers

74ABTL3205

FEATURES

- 10-bit BTL transceiver
- Drives heavily loaded backplanes with equivalent load impedances down to 10 ohms
- High drive 100mA BTL open collector drivers on B-port
- Allows incident wave switching in heavily loaded backplane buses
- Reduced BTL voltage swing produces less noise and reduces power consumption
- Built-in precision band-gap reference provides accurate receiver thresholds and improved noise immunity
- Compatible with IEEE Futurebus+ or proprietary BTL backplanes
- Controlled output ramp and multiple GND pins minimize ground bounce
- Tight output skew (0.5nsec typical)
- Glitch-free power up/down operation
- Low I_{CC} current
- Supports live insertion
- High density packaging
- ESD protection exceeds 2000V per MIL STD 883 Method 3015 and 200V per Machine Model

DESCRIPTION

This transceiver is a 10 bit bidirectional transceiver and is intended to provide the electrical interface to a high performance wired-OR bus.

The B-port drivers are Low-capacitance open collectors with controlled ramp and are designed to sink 100mA. Precision band gap references on the B-port insure very good margins by limiting the switching threshold to a narrow region centered at 1.55V.

The B-port interfaces to "Backplane Transceiver Logic" (See the IEEE 1194.1 BTL standard). BTL features low power consumption by reducing voltage swing (1V p-p, between 1V and 2V) and reduced capacitive loading (<6pF) by placing an internal series diode on the drivers. BTL also provides incident wave switching, a necessity for high performance backplanes.

To support live insertion, OEB is held Low during power on/off cycles to insure glitch free B port drivers. Proper bias for B port drivers during live insertion is provided by the BIAS V pin when at a 5V level while V_{CC} is Low. The BIAS V pin is a low current input which will reverse bias the BTL driver series Schottky diode, and also bias the B port output pins to a voltage between 1.62V and 2.1V. This bias function is in accordance with IEEE BTL standard 1194.1. If live insertion is not a requirement, the BIAS V pin should be tied to a V_{CC} pin.

The LOGIC GND and BUS GND pins are isolated inside the package to minimize noise coupling between the BTL and TTL sides. These pins should be tied to a common ground external to the package. The LOGIC V_{CC} and BUS V_{CC} pins are also isolated internally to minimize noise and may be externally decoupled separately or simply tied together.

This transceiver function is intended to operate in a half-duplex mode. Low current in standby mode is obtained by powering down unused circuitry. Likewise, transmit circuitry is powered down when in receive mode and receive circuitry is powered down while in transmit mode.

QUICK REFERENCE DATA

SYMBOL	PARAMETER		TYPICAL	UNIT
t_{PLH} t_{PHL}	Propagation delay An to \overline{Bn}		3.3 3.7	ns
t_{PLH} t_{PHL}	Propagation delay \overline{Bn} to An		3.6 3.5	ns
C_{OB}	Output capacitance ($\overline{B0}$ - $\overline{B8}$) only)		6	pF
I_{OL}	Output current ($\overline{B0}$ - $\overline{B8}$) only)		100	mA
I_{CC}	Supply current	Standby	1	mA
		An to \overline{Bn}	7	
		\overline{Bn} to An	18	

ORDERING INFORMATION

PACKAGES	TEMPERATURE RANGE	OUTSIDE NORTH AMERICA	NORTH AMERICA	DWG NUMBER
52-PIN PQFP	-40°C to +85°C	74ABTL3205 BB	74ABTL3205 BB	SOT379-1

10-bit BTL transceiver with registers

74ABTL3205

PIN CONFIGURATION

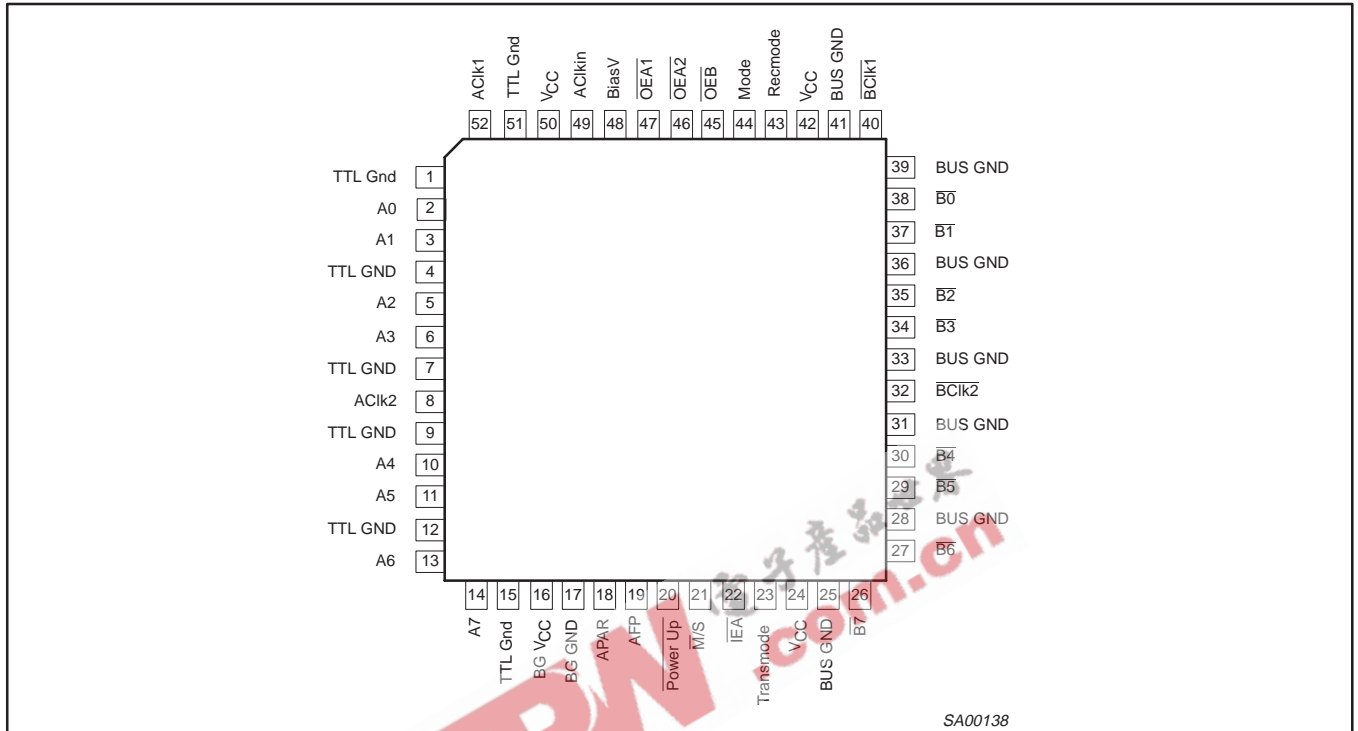

SA00138

PIN DESCRIPTION

SYMBOL	FUNCTION	ASSERTION	I/O	LOGIC
OEA1	Output enable data receiver group 1	Low	Input	TTL
OEA2	Output enable data receiver group 2	Low	Input	TTL
OEB	Output enable data transmitter	Low	Input	TTL
IEA	Output enable clock and framepulse receiver	Low	Input	TTL
M/S	Master/Slave select: L: Master, enable clock transmitter H: Slave, disable clock transmitter		Input	TTL
Mode	Low: Data through mode High: Registered data mode		Input	TTL
Power Up	Power up mode, held low during power up to disable clock and data transmitters	Low	Input	TTL
Recmode	Enables receiver	High	Input	TTL
Tranmode	Enables transmitter	High	Input	TTL
ACIk1	Clock or data path		I/O	TTL
ACIkIn	IEA = H → Input for busclock IEA = L → Output for busclock		I/O	TTL
A0..A3	data group 1		I/O	TTL
ACIk2	Clock or data path		I/O	TTL
AFPIn	Alternate data path		Output	TTL
APAR	Alternate data path		Input	TTL
A4..A7	data group 2		I/O	TTL
BCIk1	Clock or data path		I/O	BTL
B0..B3	data group 1		I/O	BTL
BCIk2	Clock or data path		I/O	BTL
B4..B7	data group 2		I/O	BTL

10-bit BTL transceiver with registers

74ABTL3205

LOGIC DIAGRAM

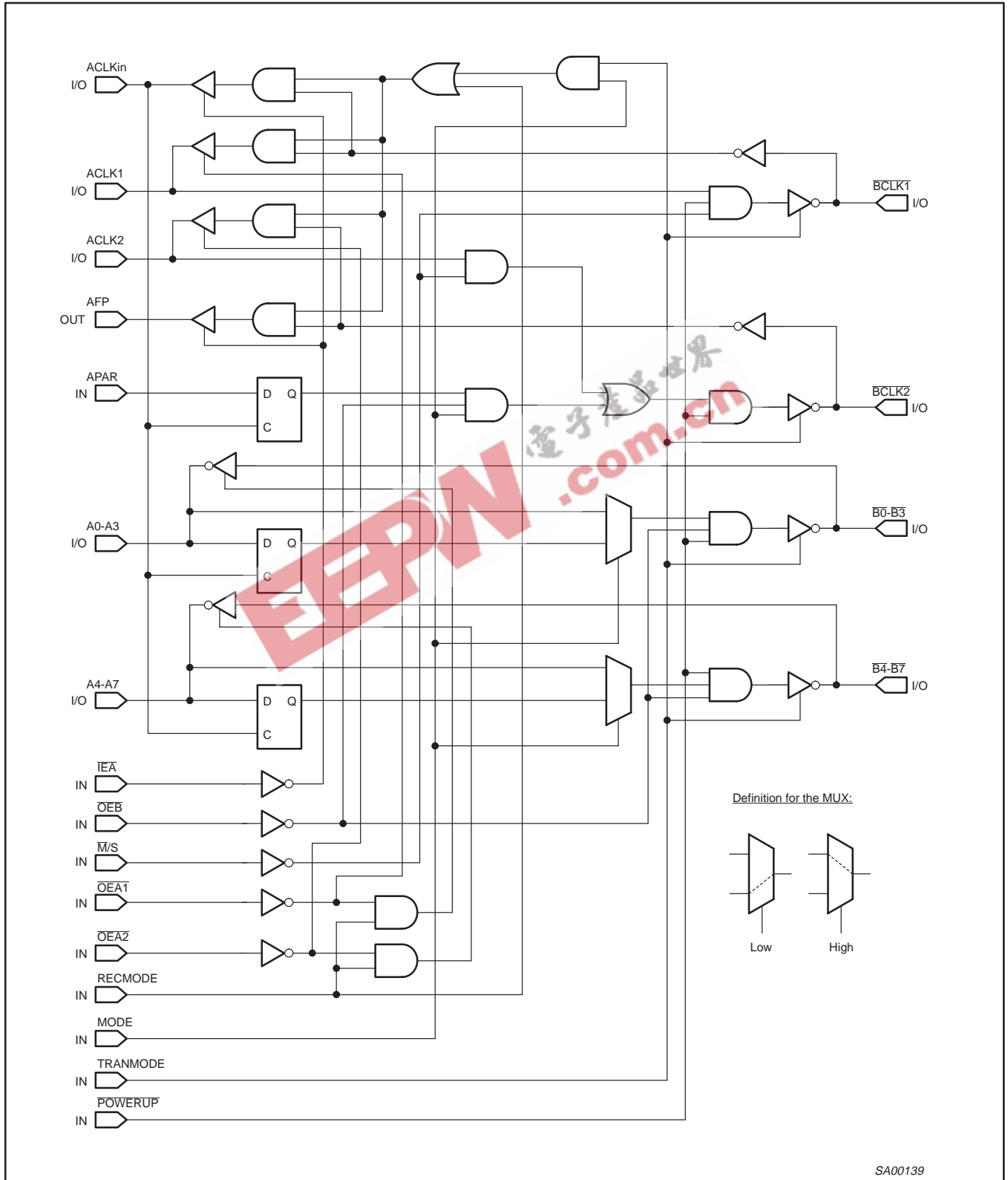

10-bit BTL transceiver with registers

74ABTL3205

FUNCTION TABLE

MODE	INPUTS																
	An	\overline{Bn}	ACLK in	ACLK 1	ACLK 2	BCLK 1	BCLK 2	OEAT	OEA2	OEB	APAR	IEA	M/S	MODE	REC MODE	TRAN MODE	POWER UP
An to Bn (REGISTERED)	I	O	↑	X	X	X	X	H	H	L	X	H	X	H	L	H	H
	h	O	↑	X	X	X	X	H	H	L	X	H	X	H	L	H	H
AN to Bn (THROUGH)	L	O	X	X	X	X	X	H	H	L	X	X	X	L	L	H	H
	H	O	X	X	X	X	X	H	H	L	X	X	X	L	L	H	H
B0-B3 to A0-A3 (THROUGH)	O	L	X	X	X	X	X	L	X	H	X	X	X	X	H	L	L
	O	H	X	X	X	X	X	L	X	H	X	X	X	X	H	L	L
B4-B7 to A4-A7 (THROUGH)	O	L	X	X	X	X	X	X	L	H	X	X	X	X	H	L	L
	O	H	X	X	X	X	X	X	L	H	X	X	X	X	H	L	L
ACLK1 to BCLK1	X	X	X	L	X	O	X	H	X	X	X	X	L	X	X	H	H
	X	X	X	H	X	O	X	H	X	X	X	X	L	X	X	H	H
ACLK2 to BCLK2	X	X	X	X	L	X	O	X	H	H	X	X	L	L	X	H	H
	X	X	X	X	H	X	O	X	H	H	X	X	L	L	X	H	H
BCLK1 to ACLK1	X	X	X	O	X	L	X	L	X	X	X	X	X	X	H	L	X
	X	X	X	O	X	H	X	L	X	X	X	X	X	X	H	L	X
BCLK2 to ACLK2	X	X	X	X	O	X	L	X	L	X	X	X	X	X	H	L	X
	X	X	X	X	O	X	H	X	L	X	X	X	X	X	H	L	X
APAR to BCLK2	X	X	↑	X	X	X	X	X	X	L	I	X	H	H	X	H	H
	X	X	↑	X	X	X	X	X	X	L	h	X	H	H	X	H	H
BCLK2 to AFPIn	X	X	X	X	X	X	L	X	X	X	X	L	X	X	H	L	X
	X	X	X	X	X	X	H	X	X	X	X	L	X	X	H	L	X
BCLK1 to ACLKin	X	X	O	X	X	L	X	H	H	L	O	L	H	H	L	H	H
	X	X	O	X	X	H	X	H	H	L	O	L	H	H	L	H	H

MODE	OUTPUTS								
	An	\overline{Bn}	ACLK in	ACLK1	ACLK2	BCLK1	BCLK2	AF Pin	
An to Bn (REGISTERED)	Input	H*	X	X	X	X	X	X	
	Input	L	X	X	X	X	X	X	
AN to Bn (THROUGH)	Input	H*	X	X	X	X	X	X	
	Input	L	X	X	X	X	X	X	
B0-B3 to A0-A3 (THROUGH)	H	Input	Input	X	X	X	X	X	
	L	Input	Input	X	X	X	X	X	
B4-B7 to A4-A7 (THROUGH)	H	Input	Input	X	X	X	X	X	
	L	Input	Input	X	X	X	X	X	
ACLK1 to BCLK1	X	X	X	Input	X	H*	X	X	
	X	X	X	Input	X	L	X	X	
ACLK2 to BCLK2	X	X	X	X	Input	X	H*	X	
	X	X	X	X	Input	X	L	X	
BCLK1 to ACLK1	X	X	X	H	X	Input	X	X	
	X	X	X	L	X	Input	X	X	
BCLK2 to ACLK2	X	X	X	X	H	X	Input	X	
	X	X	X	X	L	X	Input	X	
APAR to BCLK2	X	X	Input	X	X	X	H*	X	
	X	X	Input	X	X	X	L	X	
BCLK2 to AFPIn	X	X	X	X	X	X	Input	H*	
	X	X	X	X	X	X	Input	L	
BCLK1 to ACLKin	X	X	H	X	X	Input	X	X	
	X	X	L	X	X	Input	X	X	

NOTES:

H = High voltage level

L = Low voltage level

h = High voltage level one set-up time prior to Low to High ACLKin transition

I = Low voltage level one set-up time prior to Low to High ACLKin transition

↑ = Low to High transition

Z = High impedance (off) state

H* = Goes to level of pull-up voltage

X = Don't care

O = Output

10-bit BTL transceiver with registers

74ABTL3205

LOGIC SYMBOL (IEEE/IEC)

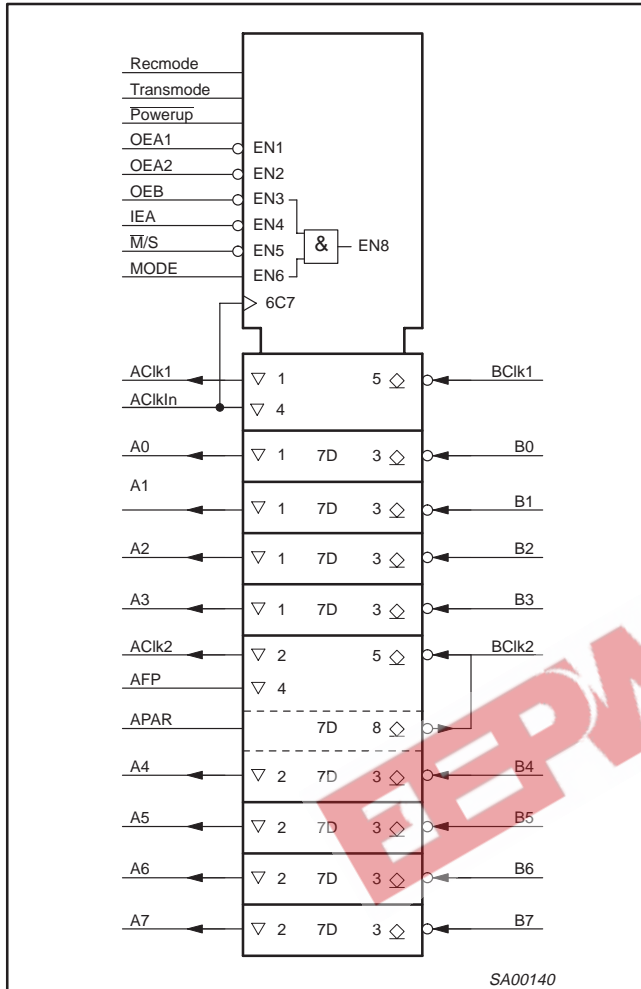

ABSOLUTE MAXIMUM RATINGS

Operation beyond the limits set forth in this table may impair the useful life of the device. Unless otherwise noted, these limits are over the operating free-air temperature range.

SYMBOL	PARAMETER		RATING	UNIT
V _{CC}	Supply voltage		-0.5 to +7.0	V
V _{IN}	Input voltage	TTL Signals	-1.2 to +7.0	V
		BTL Signals	-1.2 to +5.5	V
I _{IN}	Input current		-18 to +5	mA
V _{OUT}	Voltage applied to output in High output state		-0.5 to +V _{CC}	/V
I _{OUT}	Current applied to output in Low output state	A0 - A8	48	mA
		B0 - B8	200	mA
T _{amb}	Operating free-air temperature range		-40 to +85	°C
T _{STG}	Storage temperature		-65 to +150	°C

10-bit BTL transceiver with registers

74ABTL3205

DC ELECTRICAL CHARACTERISTICS

Over recommended operating free-air temperature range unless otherwise noted.

SYMBOL	PARAMETER		TEST CONDITIONS ¹	LIMITS			UNIT
				MIN	TYP ²	MAX	
I _{OH}	High level output current	BTL	V _{CC} = MAX, V _{IL} = MAX, V _{IH} = MIN, V _{OH} = 1.9V		0.5	100	μA
I _{OFF}	Power-off output current	BTL	V _{CC} = 0.0V, V _{IL} = MAX, V _{IH} = MIN, V _{OH} = 1.9V		10	100	μA
V _{OH}	High-level output voltage	TTL	V _{CC} = MIN, V _{IL} = MAX, ⁴ V _{IH} = MIN, I _{OH} = -3mA	2.5	2.85	3.4	V
			V _{CC} = MIN to MAX, ⁴ V _{IL} = MAX, V _{IH} = MIN, I _{OH} = -10μA			V _{CC} - 1.1	V
V _{OL}	Low-level output voltage	TTL	V _{CC} = MIN, V _{IL} = MAX, V _{IH} = MIN, I _{OL} = 24mA		0.35	0.5	V
		BTL	V _{CC} = MIN, V _{IL} = MAX, V _{IH} = MIN, I _{OL} = 100mA	0.75	1.0	1.10	V
			V _{CC} = MIN, V _{IL} = MAX, V _{IH} = MIN, I _{OL} = 4mA	0.5	0.7		V
V _{IK}	Input clamp voltage	TTL	V _{CC} = MIN, I _I = I _{IK}		0.8	-1.2	V
		BTL	V _{CC} = MIN, I _I = -18mA		0.8	-1.2	V
I _I	Input current at maximum input voltage	TTL	V _{CC} = MAX, V _I = 0.5V or 5.5V		0.1	±50	μA
I _{IH}	High-level input current	TTL	V _{CC} = MAX, V _I = 2.7V, B _n = A _n = 0V		0.1	20	μA
		BTL	V _{CC} = MAX, V _I = 1.9V		0.1	100	μA
			V _{CC} = MAX, V _I = 3.5V ⁵	100			mA
I _{IL}	Low-level input current	TTL	V _{CC} = MAX, V _I = 0.5V		0.1	-20	μA
		BTL	V _{CC} = MAX, V _I = 0.75V		0.1	-100	μA
I _{OZH}	Off-state output current	TTL	V _{CC} = MAX, V _O = 2.7V		0.1	50	μA
I _{OZL}	Off-state output current	TTL	V _{CC} = MAX, V _O = 0.5V		20	-50	μA
I _{OS}	Short-circuit output current ³	TTL	V _{CC} = MAX, V _O = 0.0V	-60	130	-150	mA
I _{CC}	Supply current (total)	Recmode Low Tranmode Low	V _{CC} = MAX		1	3	mA
		Recmode Low Tranmode High	V _{CC} = MAX Mode = Low		7	12	mA
		Recmode Low Tranmode High	V _{CC} = MAX Mode = High		13	21	mA
		Recmode High Tranmode Low	V _{CC} = MAX		18	25	mA
		Recmode High Tranmode High	V _{CC} = MAX		29	43	mA

NOTES:

- For conditions shown as MIN or MAX, use the appropriate value specified under recommended operating conditions for the applicable type.
- All typical values are at V_{CC} = 5V, T_{amb} = 25°C.
- Not more than one output should be shorted at a time. For testing I_{OS}, the use of high-speed test apparatus and/or sample-and-hold techniques are preferable in order to minimize internal heating and more accurately reflect operational values. Otherwise, prolonged shorting of a High output may raise the chip temperature well above normal and thereby cause invalid readings in other parameter tests. In any sequence of parameter tests, I_{OS} tests should be performed last.
- Due to test equipment limitations, actual test conditions are V_{IH} = 1.8V and V_{IL} = 1.3V for the B side.
- For B port input voltage between 3 and 5 volts I_{IH} will be greater than 100μA, but the parts will continue to function normally.

TTL signals CLKIn, CLK-1/CLK-OUT, CLK-2/FP-OUT, /FP-IN, /PARITY t,A0..A7, OEB, MASTER/SLAVE, MODE, OEA1, OEA2

BTL signals CLK1BTL, CLK2BTL, B0..B7

10-bit BTL transceiver with registers

74ABTL3205

LIVE INSERTION SPECIFICATIONS

SYMBOL	PARAMETER		LIMITS			UNIT
			MIN	NOM	MAX	
V_{BIASV}	Bias pin DC current	$V_{CC} = 0$ to 5.25V, $\overline{Bn} = 0$ to 2.0 V	4.5		5.5	V
I_{BIASV}	Bias pin DC current	$V_{CC} = 0$ to 4.75 V, $\overline{Bn} = 0$ to 2.0V, Bias V = 4.5 to 5.5V			1	mA
		$V_{CC} = 4.5$ to 5.5V, $\overline{Bn} = 0$ to 2.0 V, Bias V = 4.5 to 5.5V			10	μ A
\sqrt{Bn}	Bus voltage during prebias	$\overline{B0} - \overline{B8} = 0$ V, Bias V = 5.0V	1.62		2.1	V

AC ELECTRICAL CHARACTERISTICS

SYMBOL	PARAMETER	TEST CONDITION	A PORT LIMITS					UNIT
			$T_{amb} = +25^{\circ}\text{C}$ $V_{CC} = 5\text{V}$ $C_L = 50\text{pF}, C_L = 500\Omega$			$T_{amb} = -40^{\circ}\text{C to } +85^{\circ}\text{C}$ $V_{CC} = 5\text{V} \pm 10\%$ $C_L = 50\text{pF}, C_L = 500\Omega$		
			MIN	TYP	MAX	MIN	MAX	
t_{PLH} t_{PHL}	Propagation delay \overline{Bn} to An	Waveform 2	2.0 1.8	3.6 3.5	6.5 6.1	2.0 1.8	7.3 6.7	ns
t_{PLH} t_{PHL}	Propagation delay, BCLK1 to ACLK1	Waveform 2	2.0 1.8	3.8 3.6	6.5 6.1	2.0 1.8	7.3 6.7	ns
t_{PLH} t_{PHL}	Propagation delay BCLK1 to ACLKIn	Waveform 2	2.0 1.8	3.7 3.7	6.5 6.1	2.0 1.8	7.3 6.7	ns
t_{PLH} t_{PHL}	Propagation delay BCLK2 to ACLK2	Waveform 2	2.0 1.8	3.7 3.9	6.5 6.1	2.0 1.8	7.3 6.7	ns
t_{PLH} t_{PHL}	Propagation delay BCLK2 to AFP	Waveform 2	2.0 1.8	3.8 3.9	6.5 6.1	2.0 1.8	7.3 6.7	ns
t_{PZH} t_{PLZ}	Output Enable time OEA1, OEA2, IEA to An	Waveform 1, 2	2.0 1.8	3.8 2.5	6.5 6.1	2.0 1.8	7.3 6.7	ns
t_{PHZ} t_{PLZ}	Output Disable time OEA1, OEA2, IEA to An	Waveform 4, 5	1.6 2.0	2.5 3.3	5.6 7.8	1.4 1.8	5.7 8.2	ns
t_{TLH} t_{THL}	Output transition time, An Port 10% to 90%, 90% to 10%	Test Circuit and Waveforms				3.0 1.7	7.0 4.0	ns
$t_{sk(p)}$	Pulse skew ² $ t_{PHL} - t_{PLH} _{MAX}$	Waveform 3		2.0				ns

NOTES:

- $|t_{PN} \text{ actual} - t_{PM} \text{ actual}|$ for any data input to output path compared to any other data input to output path where N and M are either LH or HL. Skew times are valid only under same test conditions (temperature, V_{CC} , loading, etc.).
- $t_{sk(p)}$ is used to quantify duty cycle characteristics. In essence it compares the input signal duty cycle to the corresponding output signal duty cycle. (50MHz input frequency and 50% duty cycle, tested on data paths only).

10-bit BTL transceiver with registers

74ABTL3205

AC ELECTRICAL CHARACTERISTICS

SYMBOL	PARAMETER	TEST CONDITION	B PORT LIMITS					UNIT
			T _{amb} = +25°C V _{CC} = 5V C _D = 30pF, R _U = 18.5Ω			T _{amb} = -40°C to +85°C V _{CC} = 5V ± 10% C _L = 30pF, R _U = 18.5Ω		
			MIN	TYP	MAX	MIN	MAX	
t _{PLH} t _{PHL}	Propagation delay An to B _n	Waveform 2	1.0 1.0	3.3 2.7	4.7 4.5	1.0 1.0	5.7	ns
t _{PLH} t _{PHL}	Propagation delay, ACLK _{in} to B _n	Waveform 1, 2	2.0 2.0	4.6 4.5	5.9 5.9	2.0 2.0	6.3 6.3	ns
t _{PLH} t _{PHL}	Propagation delay ACLK _{in} to BCLK2	Waveform 1, 2	2.0 2.0	4.6 4.5	7.3 7.3	2.0 2.0	7.6 7.6	ns
t _{PLH} t _{PHL}	Propagation delay ACLK1 to BCLK1	Waveform 2	1.0 1.0	3.2 2.9	4.7 4.5	1.0 1.0	5.1 4.7	ns
t _{PLH} t _{PHL}	Propagation delay ACLK2 to BCLK2	Waveform 2	1.0 1.0	3.1 3.1	5.7 5.5	1.0 1.0	6.0 5.6	ns
t _{PLH} t _{PHL}	Enable/disable time OEB to B _n or BCLK2	Waveform 1, 2	1.0 1.0	3.8 3.4	6.8 6.4	1.0 1.0	7.6 6.9	ns
t _{TLH} t _{THL}	Transition time, B _n Port (1.3V to 1.8V)	Test Circuit and Waveforms	1.0 0.6		2.5 2.0	1.0 0.6	3.0 2.5	ns
t _{sk(p)}	Pulse skew2 t _{PHL} - t _{PLH} MAX	Waveform 3		2.0				ns

NOTES:

1. |t_{PN} actual - t_{PM} actual| for any data input to output path compared to any other data input to output path where N and M are either LH or HL. Skew times are valid only under same test conditions (temperature, V_{CC}, loading, etc.).
2. t_{sk(p)} is used to quantify duty cycle characteristics. In essence it compares the input signal duty cycle to the corresponding output signal duty cycle. (50MHz input frequency and 50% duty cycle, tested on data paths only).

AC SETUP REQUIREMENTS

SYMBOL	PARAMETER	TEST CONDITION	LIMITS				UNIT
			T _{amb} = +25°C V _{CC} = 5V		T _{amb} = -40°C to +85°C V _{CC} = 5V ± 10%		
			C _L = 50pF (A side) / C _D = 30pF (B side) R _L = 500Ω (A side) / R _U = 18.5Ω (B side)				
			MIN	TYP	MIN	MAX	
t _{s(H)} t _{s(L)}	Setup time An to ACLK _{in}	Waveform 6	1.9 1.3		2.0 1.5		ns
t _{h(H)} t _{h(L)}	Hold time An to ACLK _{in}	Waveform 6	1.8 2.0		2.3 2.0		ns

10-bit BTL transceiver with registers

74ABTL3205

AC WAVEFORMS

$V_M = 1.55V$ for \overline{Bn} , $V_M = 1.5V$ for all others

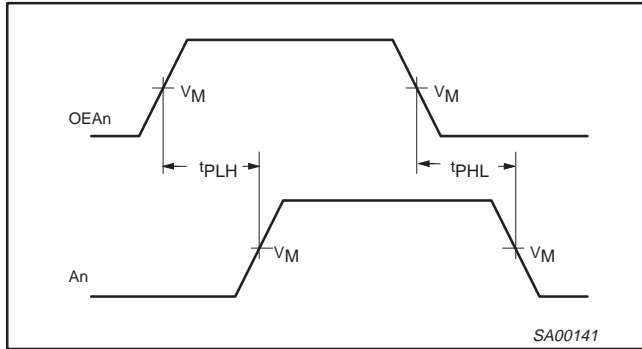

Waveform 1. Propagation Delay for Data or Output Enable to Output

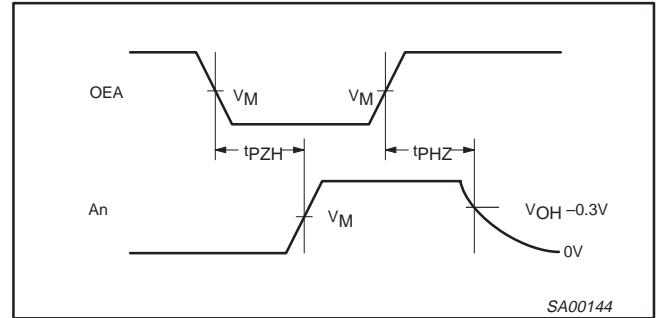

Waveform 4. 3-State Output Enable Time to High Level and Output Disable Time from High Level

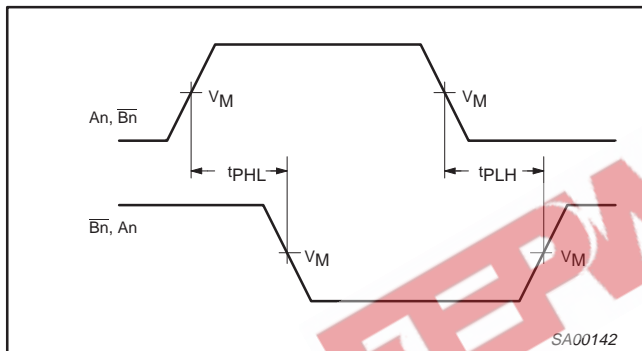

Waveform 2. Propagation Delay for Data to Output

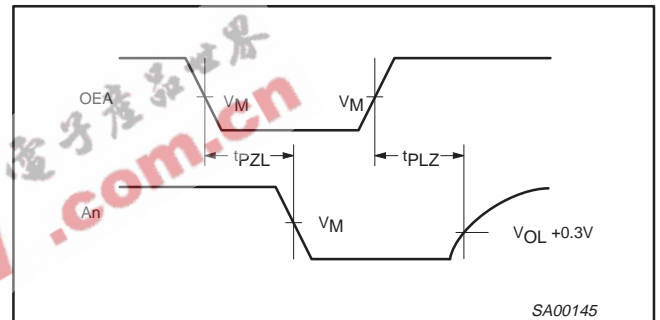

Waveform 5. 3-State Output Enable Time to Low Level and Output Disable Time from Low Level

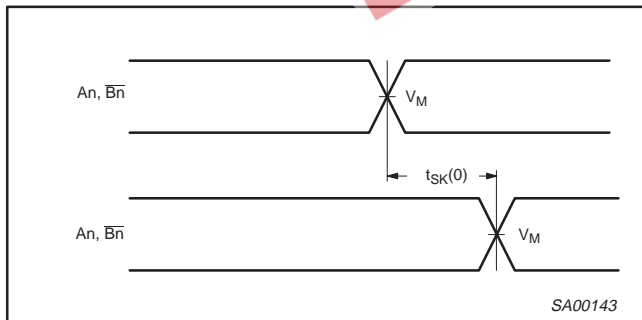

Waveform 3. Output Skews

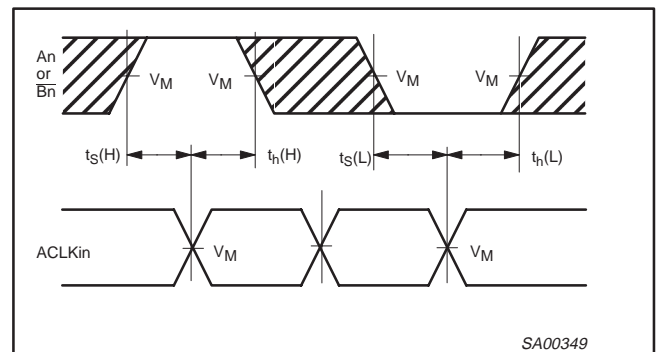

Waveform 6. Data Setup and Hold Times

10-bit BTL transceiver with registers

74ABTL3205

TEST CIRCUIT AND WAVEFORMS

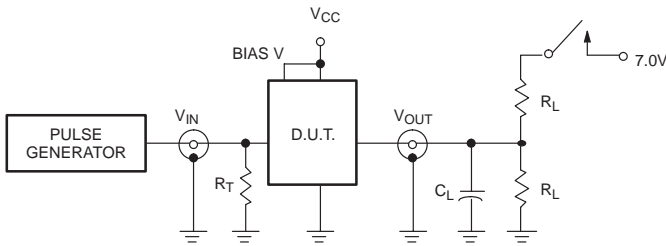

Test Circuit for 3-State Outputs on A Port

SWITCH POSITION

TEST	SWITCH
t_{PLZ} , t_{PZL}	closed
All other	open

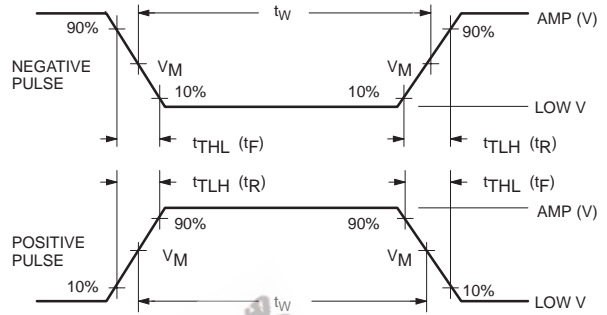

$V_M = 1.55V$ for B_n or \overline{B}_n , $V_M = 1.5V$ for all others

Input Pulse Definition

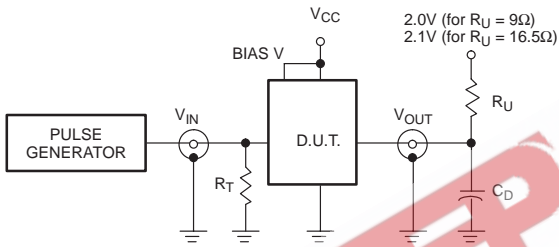

Test Circuit for Outputs on B Port

ABTL	INPUT PULSE REQUIREMENTS					
	Amplitude	Low V	Rep. Rate	t_W	t_{TLH}	t_{THL}
A Port	3.0V	0.0V	1MHz	500ns	2.5ns	2.5ns
B Port	2.0V	1.0V	1MHz	500ns	2.5ns	2.5ns

DEFINITIONS

- R_L = Load resistor; see AC CHARACTERISTICS for value.
- C_L = Load capacitance includes jig and probe capacitance; see AC CHARACTERISTICS for value.
- R_T = Termination resistance should be equal to Z_{OUT} of pulse generators.
- C_D = Load capacitance includes jig and probe capacitance; see AC CHARACTERISTICS for value.
- R_U = Pull up resistor; see AC CHARACTERISTICS for value.

SA00146

10-bit BTL transceiver with registers

74ABTL3205

QFP52: plastic quad flat package; 52 leads (lead length 1.6 mm); body 10 x 10 x 2.0 mm

SOT379-1

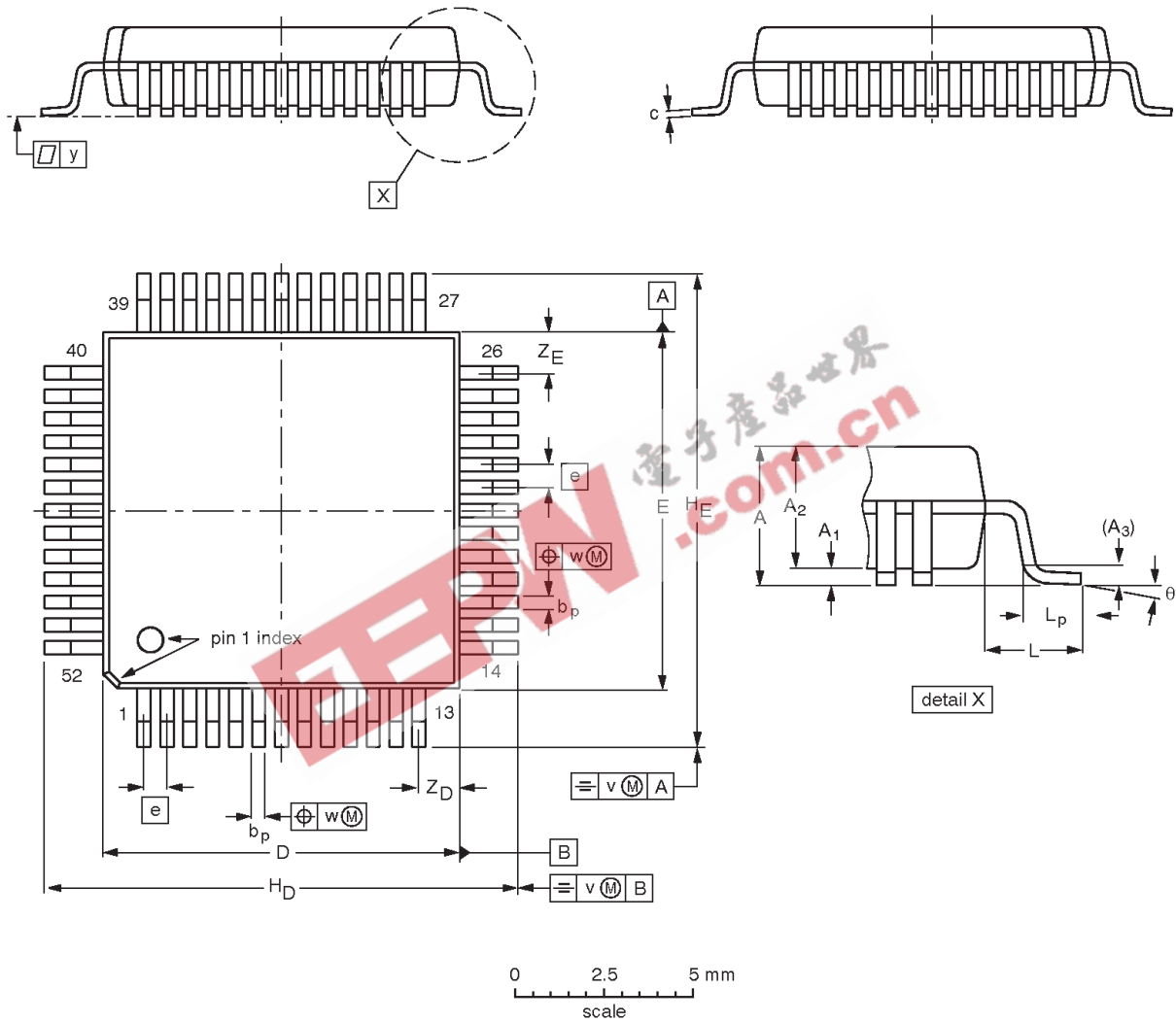

DIMENSIONS (mm are the original dimensions)

UNIT	A max.	A ₁	A ₂	A ₃	b _p	c	D ⁽¹⁾	E ⁽¹⁾	e	H _D	H _E	L	L _p	v	w	y	Z _D ⁽¹⁾	Z _E ⁽¹⁾	θ
mm	2.45	0.45 0.25	2.10 1.95	0.25	0.38 0.22	0.23 0.13	10.1 9.9	10.1 9.9	0.65	13.45 12.95	13.45 12.95	1.60	0.95 0.65	0.20	0.12	0.10	1.24 0.95	1.24 0.95	7° 0°

Note

1. Plastic or metal protrusions of 0.25 mm maximum per side are not included.

OUTLINE VERSION	REFERENCES				EUROPEAN PROJECTION	ISSUE DATE
	IEC	JEDEC	EIAJ			
SOT379-1		MO-108				95-02-04 97-08-04

10-bit BTL transceiver with registers

74ABTL3205

NOTES



10-bit BTL transceiver with registers

74ABTL3205

Data sheet status

Data sheet status	Product status	Definition [1]
Objective specification	Development	This data sheet contains the design target or goal specifications for product development. Specification may change in any manner without notice.
Preliminary specification	Qualification	This data sheet contains preliminary data, and supplementary data will be published at a later date. Philips Semiconductors reserves the right to make changes at any time without notice in order to improve design and supply the best possible product.
Product specification	Production	This data sheet contains final specifications. Philips Semiconductors reserves the right to make changes at any time without notice in order to improve design and supply the best possible product.

[1] Please consult the most recently issued datasheet before initiating or completing a design.

Definitions

Short-form specification — The data in a short-form specification is extracted from a full data sheet with the same type number and title. For detailed information see the relevant data sheet or data handbook.

Limiting values definition — Limiting values given are in accordance with the Absolute Maximum Rating System (IEC 134). Stress above one or more of the limiting values may cause permanent damage to the device. These are stress ratings only and operation of the device at these or at any other conditions above those given in the Characteristics sections of the specification is not implied. Exposure to limiting values for extended periods may affect device reliability.

Application information — Applications that are described herein for any of these products are for illustrative purposes only. Philips Semiconductors make no representation or warranty that such applications will be suitable for the specified use without further testing or modification.

Disclaimers

Life support — These products are not designed for use in life support appliances, devices or systems where malfunction of these products can reasonably be expected to result in personal injury. Philips Semiconductors customers using or selling these products for use in such applications do so at their own risk and agree to fully indemnify Philips Semiconductors for any damages resulting from such application.

Right to make changes — Philips Semiconductors reserves the right to make changes, without notice, in the products, including circuits, standard cells, and/or software, described or contained herein in order to improve design and/or performance. Philips Semiconductors assumes no responsibility or liability for the use of any of these products, conveys no license or title under any patent, copyright, or mask work right to these products, and makes no representations or warranties that these products are free from patent, copyright, or mask work right infringement, unless otherwise specified.

Philips Semiconductors
811 East Arques Avenue
P.O. Box 3409
Sunnyvale, California 94088-3409
Telephone 800-234-7381

© Copyright Philips Electronics North America Corporation 2000
All rights reserved. Printed in U.S.A.

Date of release: 01-00

Document order number:

9397 750 06827

Let's make things better.