

HD74LS374 ● Octal D-type Edge-triggered Flip-Flops (with three-state outputs)

The HD74LS374, 8-bit registers features totem-pole three-state outputs designed specifically for driving highly-capacitive or relatively low-impedance loads. The high-impedance third state and increased high-logic-level drive provide this register with the capability of being connected directly to and driving the bus lines in a bus-organized system without need for interface or pull-up components. They are particularly attractive for implementing buffer registers, I/O ports, bidirectional bus drivers, and working registers. The eight flip-flops are edge-triggered D-type flip-flops. On the positive transition the clock, the Q outputs will be set to the logic states that were setup at the D inputs.

■ PIN ARRANGEMENT

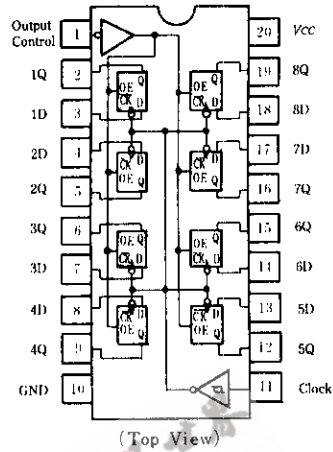

■ FUNCTION TABLE

Output control	Inputs		Output
	Clock	D	Q
L	↑	H	H
L	↑	L	L
L	L	X	Q ₀
H	X	X	Z

Notes: H = high level, L = low level,
X = irrelevant
↑ = transition from low to high level
Q₀ = level of Q before the indicated steady-state input conditions were established
Z = off (high-impedance) state of a three-state output

■ BLOCK DIAGRAM

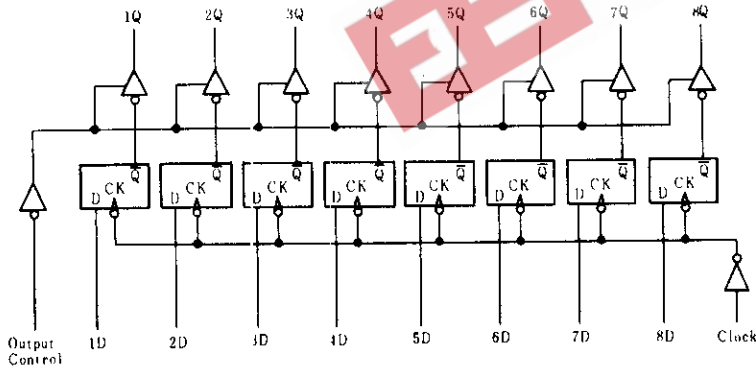

■ RECOMMENDED OPERATING CONDITION

Item	Symbol	min	typ	max	Unit
Supply voltage	V _{CC}	4.75	5.00	5.25	V
Output voltage	V _{OH}	—	—	5.5	V
Output current	I _{OH}	—	—	-2.6	mA
	I _{OL}	—	—	24	mA
Clock pulse width	"H" level	t _w	15	—	ns
	"L" level	t _w	15	—	ns
Data setup time	t _{su}	20 ↑	—	—	ns
Data hold time	t _h	3 ↑	—	—	ns

Note) ↑ : The arrow indicates the rising edge of clock pulse.

HD74LS374

■ ELECTRICAL CHARACTERISTICS ($T_a = -20 \sim +75^\circ\text{C}$)

Item	Symbol	Test Conditions	min	typ*	max	Unit	
Input voltage	V_{IH}		2.0	—	—	V	
	V_{IL}		—	—	0.8	V	
Output voltage	V_{OH}	$V_{CC}=4.75\text{V}, V_{IH}=2\text{V}, V_{IL}=0.8\text{V}, I_{OH}=-2.6\text{mA}$	2.4	—	—	V	
	V_{OL}	$V_{CC}=4.75\text{V}, V_{IH}=2\text{V}, V_{IL}=0.8\text{V}$				V	
Off-state output current	I_{OZH}	$V_{CC}=5.25\text{V}, V_{IH}=2\text{V}$	$I_{OL}=12\text{mA}$	—	—	0.4	μA
	I_{OZL}		$I_{OL}=24\text{mA}$	—	—	0.5	
Input current	I_{IH}	$V_{CC}=5.25\text{V}, V_i=2.7\text{V}$	—	—	20	μA	
	I_{IL}	$V_{CC}=5.25\text{V}, V_i=0.4\text{V}$	—	—	-0.4	mA	
	I_i	$V_{CC}=5.25\text{V}, V_i=7\text{V}$	—	—	0.1	mA	
Short-circuit output current	I_{OS}	$V_{CC}=5.25\text{V}$	-30	—	-130	mA	
Supply current	I_{CC}	$V_{CC}=5.25\text{V}, V_i=4.5\text{V}$ (Output control)	—	27	40	mA	
Input clamp voltage	V_{IK}	$V_{CC}=4.75\text{V}, I_{IK}=-18\text{mA}$	—	—	-1.5	V	

* $V_{CC}=5\text{V}, T_a=25^\circ\text{C}$

■ SWITCHING CHARACTERISTICS ($V_{CC}=5\text{V}, T_a=25^\circ\text{C}$)

Item	Symbol	Inputs	Outputs	Test Conditions	min	typ	max	Unit
Maximum clock frequency	f_{max}	Clock	Q		35	50	—	MHz
Propagation delay time	t_{PLH}	Clock	Q	$C_L=45\text{pF}$ $R_L=667\Omega$	—	15	28	ns
	t_{PHL}				—	19	28	
Output enable time	t_{ZH}	OC	Q		—	20	28	ns
	t_{ZL}				—	21	28	
Output disable time	t_{H2}	OC	Q	$C_L=5\text{pF}$ $R_L=667\Omega$	—	12	20	ns
	t_{L2}				—	14	25	

■ TESTING METHOD

Test Circuit

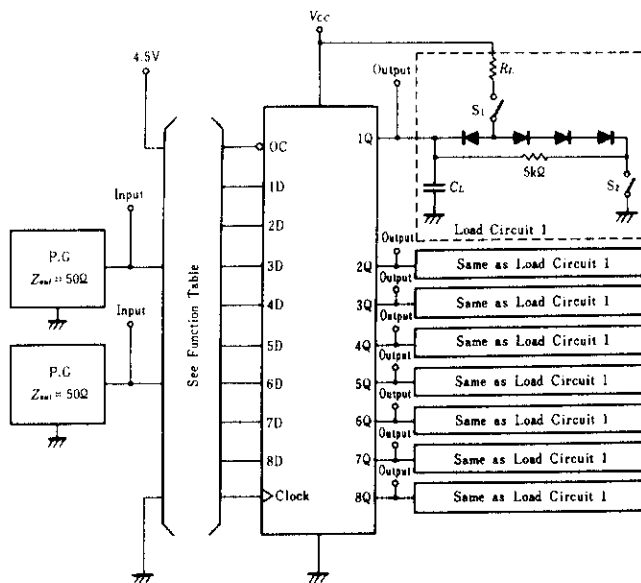

HD74LS374

Waveform-1

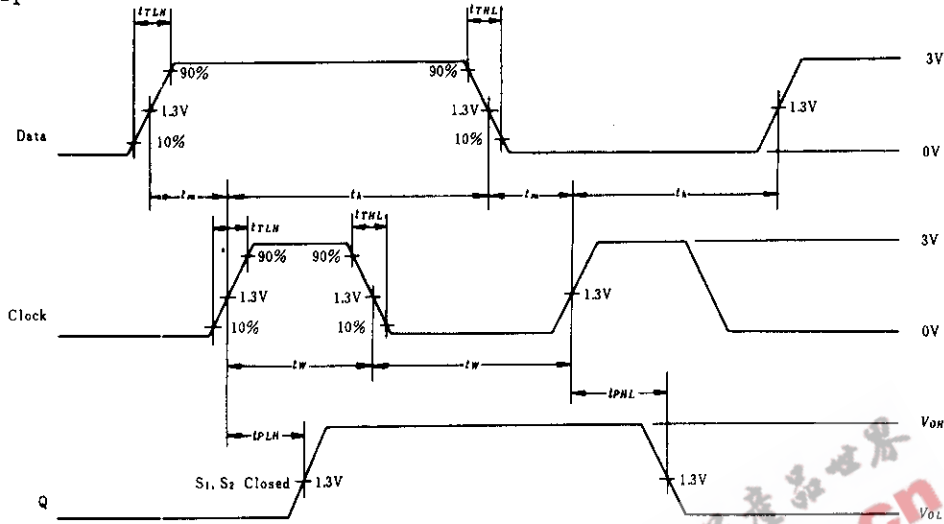

- Notes:
1. Input pulse; $t_{TLH} = 15\text{ns}$, $t_{THL} = 6\text{ns}$
 Clock input; $PRR = 1\text{MHz}$, duty cycle 50%
 Data input; $PRR = 500\text{kHz}$, duty cycle 50%
 2. f_{max} ; $t_{TLH} = 2.5\text{ns}$, $t_{THL} = 2.5\text{ns}$

Waveform-2

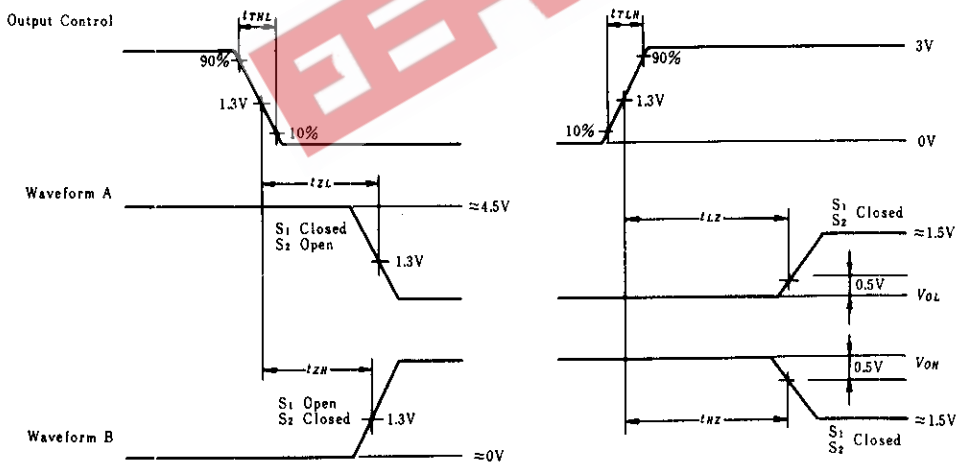

- Notes:
1. Input pulse; $t_{TLH} = 15\text{ns}$, $t_{THL} = 6\text{ns}$, $PRR = 1\text{MHz}$, duty cycle 50%
 2. Waveform A is for an output with internal conditions such that the output is low except when disabled by the output control. Waveform B is for an output with internal conditions such that the output is high except when disabled by the output control.

EEPW 电子产品世界 .com.cn

Unit: mm

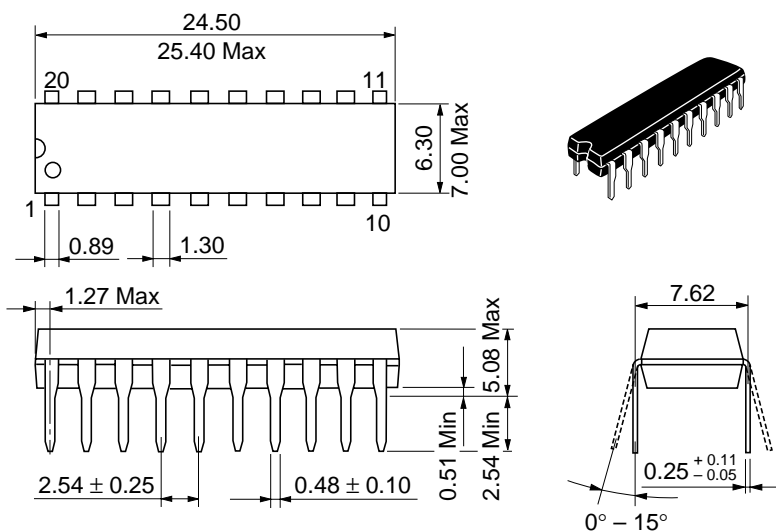

Hitachi Code	DP-20N
JEDEC	—
EIAJ	Conforms
Weight (reference value)	1.26 g

Unit: mm

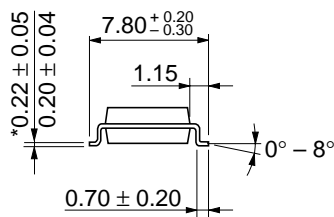
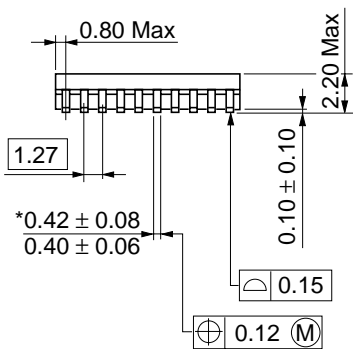
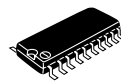
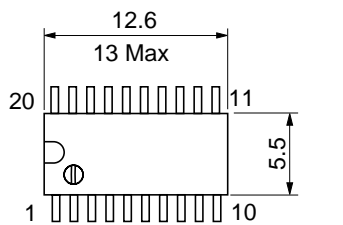

*Dimension including the plating thickness
 Base material dimension

Hitachi Code	FP-20DA
JEDEC	—
EIAJ	Conforms
Weight (reference value)	0.31 g

Unit: mm

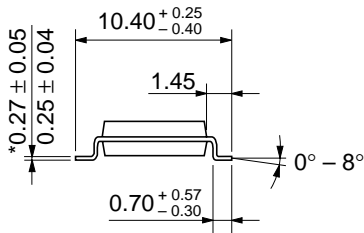
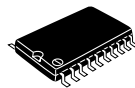
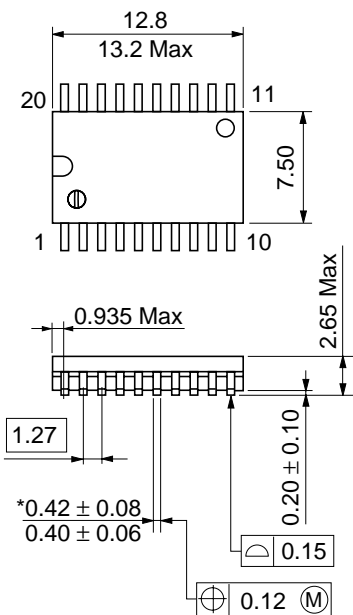

*Dimension including the plating thickness
Base material dimension

Hitachi Code	FP-20DB
JEDEC	Conforms
EIAJ	—
Weight (reference value)	0.52 g

Cautions

1. Hitachi neither warrants nor grants licenses of any rights of Hitachi's or any third party's patent, copyright, trademark, or other intellectual property rights for information contained in this document. Hitachi bears no responsibility for problems that may arise with third party's rights, including intellectual property rights, in connection with use of the information contained in this document.
2. Products and product specifications may be subject to change without notice. Confirm that you have received the latest product standards or specifications before final design, purchase or use.
3. Hitachi makes every attempt to ensure that its products are of high quality and reliability. However, contact Hitachi's sales office before using the product in an application that demands especially high quality and reliability or where its failure or malfunction may directly threaten human life or cause risk of bodily injury, such as aerospace, aeronautics, nuclear power, combustion control, transportation, traffic, safety equipment or medical equipment for life support.
4. Design your application so that the product is used within the ranges guaranteed by Hitachi particularly for maximum rating, operating supply voltage range, heat radiation characteristics, installation conditions and other characteristics. Hitachi bears no responsibility for failure or damage when used beyond the guaranteed ranges. Even within the guaranteed ranges, consider normally foreseeable failure rates or failure modes in semiconductor devices and employ systemic measures such as fail-safes, so that the equipment incorporating Hitachi product does not cause bodily injury, fire or other consequential damage due to operation of the Hitachi product.
5. This product is not designed to be radiation resistant.
6. No one is permitted to reproduce or duplicate, in any form, the whole or part of this document without written approval from Hitachi.
7. Contact Hitachi's sales office for any questions regarding this document or Hitachi semiconductor products.

HITACHI

Hitachi, Ltd.

Semiconductor & Integrated Circuits.
Nippon Bldg., 2-6-2, Ohte-machi, Chiyoda-ku, Tokyo 100-0004, Japan
Tel: Tokyo (03) 3270-2111 Fax: (03) 3270-5109

URL North America : <http://semiconductor.hitachi.com/>
 Europe : <http://www.hitachi-eu.com/hel/ecg>
 Asia (Singapore) : <http://www.has.hitachi.com.sg/grp3/sicd/index.htm>
 Asia (Taiwan) : http://www.hitachi.com.tw/E/Product/SICD_Frame.htm
 Asia (HongKong) : <http://www.hitachi.com.hk/eng/bo/grp3/index.htm>
 Japan : <http://www.hitachi.co.jp/Sicd/indx.htm>

For further information write to:

Hitachi Semiconductor
(America) Inc.
179 East Tasman Drive,
San Jose, CA 95134
Tel: <1> (408) 433-1990
Fax: <1> (408) 433-0223

Hitachi Europe GmbH
Electronic components Group
Dornacher StraÙe 3
D-85622 Feldkirchen, Munich
Germany
Tel: <49> (89) 9 9180-0
Fax: <49> (89) 9 29 30 00

Hitachi Europe Ltd.
Electronic Components Group.
Whitebrook Park
Lower Cookham Road
Maidenhead
Berkshire SL6 8YA, United Kingdom
Tel: <44> (1628) 585000
Fax: <44> (1628) 778322

Hitachi Asia Pte. Ltd.
16 Collyer Quay #20-00
Hitachi Tower
Singapore 049318
Tel: 535-2100
Fax: 535-1533

Hitachi Asia Ltd.
Taipei Branch Office
3F, Hung Kuo Building, No.167,
Tun-Hwa North Road, Taipei (105)
Tel: <886> (2) 2718-3666
Fax: <886> (2) 2718-8180

Hitachi Asia (Hong Kong) Ltd.
Group III (Electronic Components)
7/F., North Tower, World Finance Centre,
Harbour City, Canton Road, Tsim Sha Tsui,
Kowloon, Hong Kong
Tel: <852> (2) 735 9218
Fax: <852> (2) 730 0281
Telex: 40815 HITEC HX

Copyright ' Hitachi, Ltd., 1999. All rights reserved. Printed in Japan.

HITACHI