

54F/74F521 8-Bit Identity Comparator

General Description

The 'F521 is an expandable 8-bit comparator. It compares two words of up to eight bits each and provides a LOW output when the two words match bit for bit. The expansion input $\bar{I}_{A=B}$ also serves as an active LOW enable input.

Features

- Compares two 8-bit words in 6.5 ns typ
- Expandable to any word length
- 20-pin package

Commercial	Military	Package Number	Package Description
74F521PC		N20A	20-Lead (0.300" Wide) Molded Dual-In-Line
	54F521DM (Note 2)	J20A	20-Lead Ceramic Dual-In-Line
74F521SC (Note 1)		M20B	20-Lead (0.300" Wide) Molded Small Outline, JEDEC
74F521SJ (Note 1)		M20D	20-Lead (0.300" Wide) Molded Small Outline, EIAJ
74F521MSA (Note 1)		MSA20	20-Lead Molded Shrink Small Outline, EIAJ type II

Note 1: Devices also available in 13" reel. Use suffix = SCX, SJX and MSAX.

Note 2: Military grade device with environmental and burn-in processing. Use suffix = DMQB.

Logic Symbols

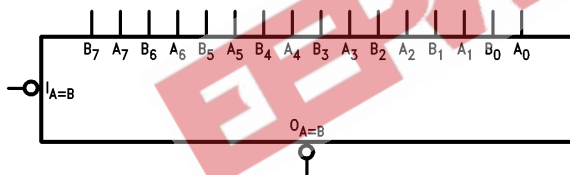

TL/F/9545-1

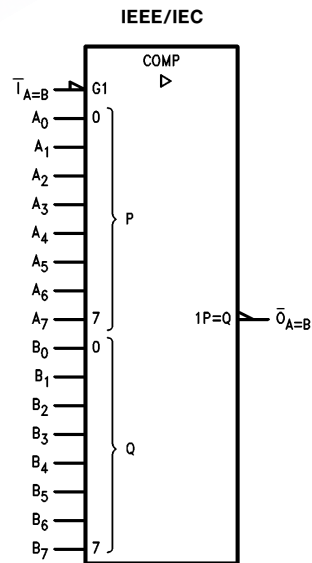

TL/F/9545-4

TRI-STATE® is a registered trademark of National Semiconductor Corporation.

Unit Loading/Fan Out

Pin Names	Description	54F/74F	
		U.L. HIGH/LOW	Input I_{IH}/I_{IL} Output I_{OH}/I_{OL}
A_0 – A_7	Word A Inputs	1.0/1.0	$20 \mu\text{A}/ -0.6 \text{ mA}$
B_0 – B_7	Word B Inputs	1.0/1.0	$20 \mu\text{A}/ -0.6 \text{ mA}$
$\bar{I}_{A=B}$	Expansion or Enable Input (Active LOW)	1.0/1.0	$20 \mu\text{A}/ -0.6 \text{ mA}$
$\bar{O}_{A=B}$	Identity Output (Active LOW)	50/33.3	$-1 \text{ mA}/ 20 \text{ mA}$

Truth Table

Inputs		Output
$\bar{I}_{A=B}$	A, B	$\bar{O}_{A=B}$
L	$A = B^*$	L
L	$A \neq B$	H
H	$A = B^*$	H
H	$A \neq B$	H

H = HIGH Voltage Level
L = LOW Voltage Level
* $A_0 = B_0, A_1 = B_1, A_2 = B_2$, etc.

Connection Diagrams

Pin Assignment for DIP, SOIC, SSOP and Flatpak

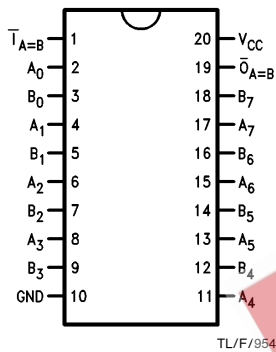

Pin Assignment for LCC

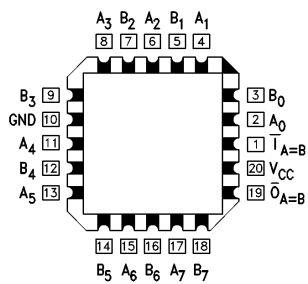

Logic Diagram

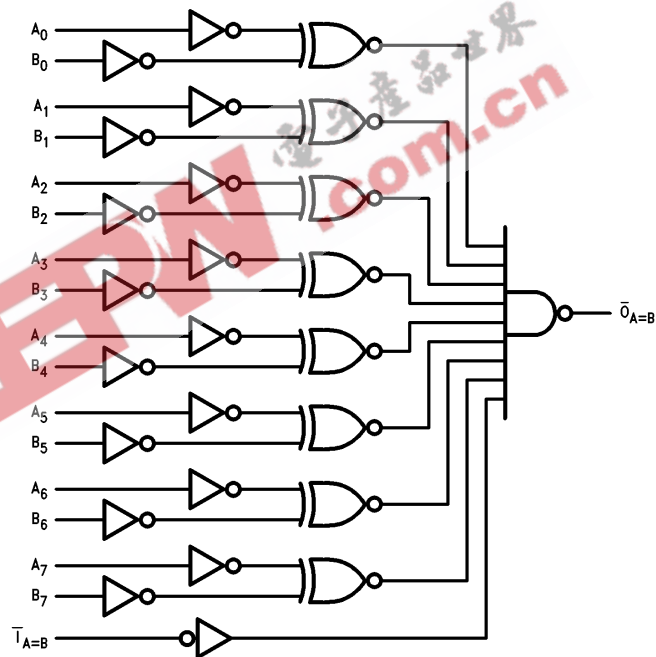

Please note that this diagram is provided only for the understanding of logic operations and should not be used to estimate propagation delays.

Absolute Maximum Ratings (Note 1)

If Military/Aerospace specified devices are required, please contact the National Semiconductor Sales Office/Distributors for availability and specifications.

Storage Temperature	-65°C to +150°C
Ambient Temperature under Bias	-55°C to +125°C
Junction Temperature under Bias	-55°C to +175°C
Plastic	-55°C to +150°C
V _{CC} Pin Potential to Ground Pin	-0.5V to +7.0V
Input Voltage (Note 2)	-0.5V to +7.0V
Input Current (Note 2)	-30 mA to +5.0 mA
Voltage Applied to Output in HIGH State (with V _{CC} = 0V)	
Standard Output	-0.5V to V _{CC}
TRI-STATE® Output	-0.5V to +5.5V

Current Applied to Output in LOW State (Max) twice the rated I_{OL} (mA)

Note 1: Absolute maximum ratings are values beyond which the device may be damaged or have its useful life impaired. Functional operation under these conditions is not implied.

Note 2: Either voltage limit or current limit is sufficient to protect inputs.

Recommended Operating Conditions

Free Air Ambient Temperature	
Military	-55°C to +125°C
Commercial	0°C to +70°C
Supply Voltage	
Military	+4.5V to +5.5V
Commercial	+4.5V to +5.5V

DC Electrical Characteristics

Symbol	Parameter	54F/74F			Units	V _{CC}	Conditions
		Min	Typ	Max			
V _{IH}	Input HIGH Voltage	2.0			V		Recognized as a HIGH Signal
V _{IL}	Input LOW Voltage			0.8	V		Recognized as a LOW Signal
V _{CD}	Input Clamp Diode Voltage			-1.2	V	Min	I _{IN} = -18 mA
V _{OH}	Output HIGH Voltage	54F 10% V _{CC} 74F 10% V _{CC} 74F 5% V _{CC}	2.5 2.5 2.7		V	Min	I _{OH} = -1 mA I _{OH} = -1 mA I _{OH} = -1 mA
V _{OL}	Output LOW Voltage	54F 10% V _{CC} 74F 10% V _{CC}		0.5 0.5	V	Min	I _{OL} = 20 mA I _{OL} = 20 mA
I _{IH}	Input HIGH Current	54F 74F		20.0 5.0	μA	Max	V _{IN} = 2.7V
I _{BVI}	Input HIGH Current Breakdown Test	54F 74F		100 7.0	μA	Max	V _{IN} = 7.0V
I _{CEx}	Output HIGH Leakage Current	54F 74F		250 50	μA	Max	V _{OUT} = V _{CC}
V _{ID}	Input Leakage Test	74F	4.75		V	0.0	I _{ID} = 1.9 μA All Other Pins Grounded
I _{OD}	Output Leakage Circuit Current	74F		3.75	μA	0.0	V _{IOD} = 150 mV All Other Pins Grounded
I _{IL}	Input LOW Current			-0.6	mA	Max	V _{IN} = 0.5V
I _{OS}	Output Short-Circuit Current			-60 -150	mA	Max	V _{OUT} = 0V
I _{CCH}	Power Supply Current		21 32		mA	Max	V _O = HIGH

AC Electrical Characteristics

Symbol	Parameter	74F			54F		74F		Units
		$T_A = +25^\circ\text{C}$ $V_{CC} = +5.0\text{V}$ $C_L = 50\text{ pF}$			$T_A, V_{CC} = \text{Mil}$ $C_L = 50\text{ pF}$		$T_A, V_{CC} = \text{Com}$ $C_L = 50\text{ pF}$		
		Min	Typ	Max	Min	Max	Min	Max	
t_{PLH} t_{PHL}	Propagation Delay A_n or B_n to $\overline{O}_{A=B}$	3.0 4.5	7.0 7.0	10.0 10.0	3.0 4.0	14.0 15.0	3.0 4.0	11.0 11.0	ns
t_{PLH} t_{PHL}	Propagation Delay $\overline{I}_{A=B}$ to $\overline{O}_{A=B}$	3.0 3.5	5.0 6.5	6.5 9.0	3.0 3.5	8.5 13.5	3.0 3.5	7.5 10.0	ns

Applications

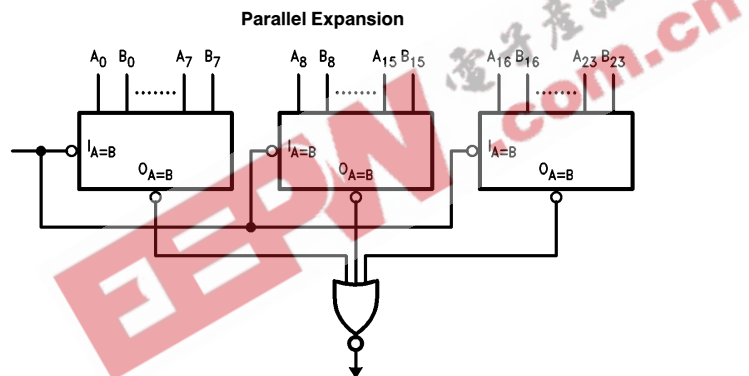
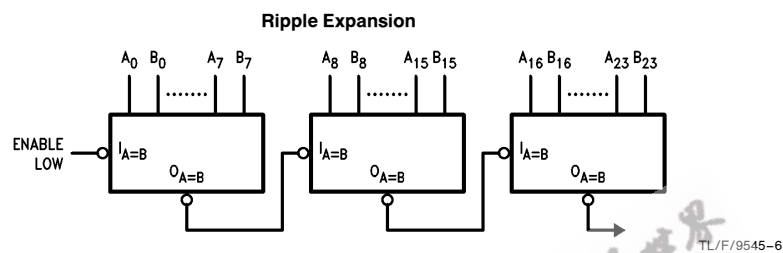

Ordering Information

The device number is used to form part of a simplified purchasing code where the package type and temperature range are defined as follows:

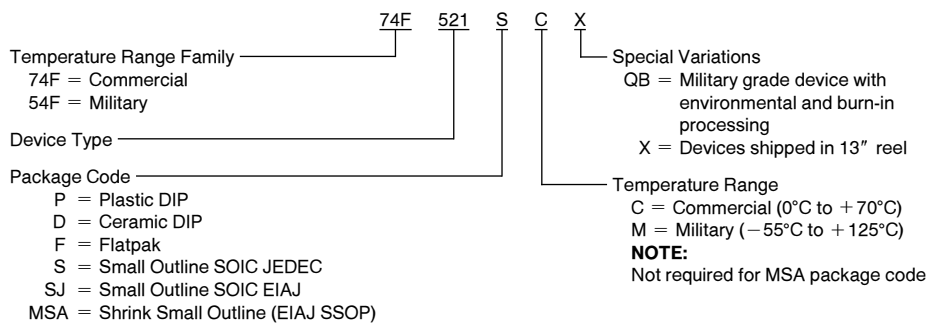

Physical Dimensions inches (millimeters)

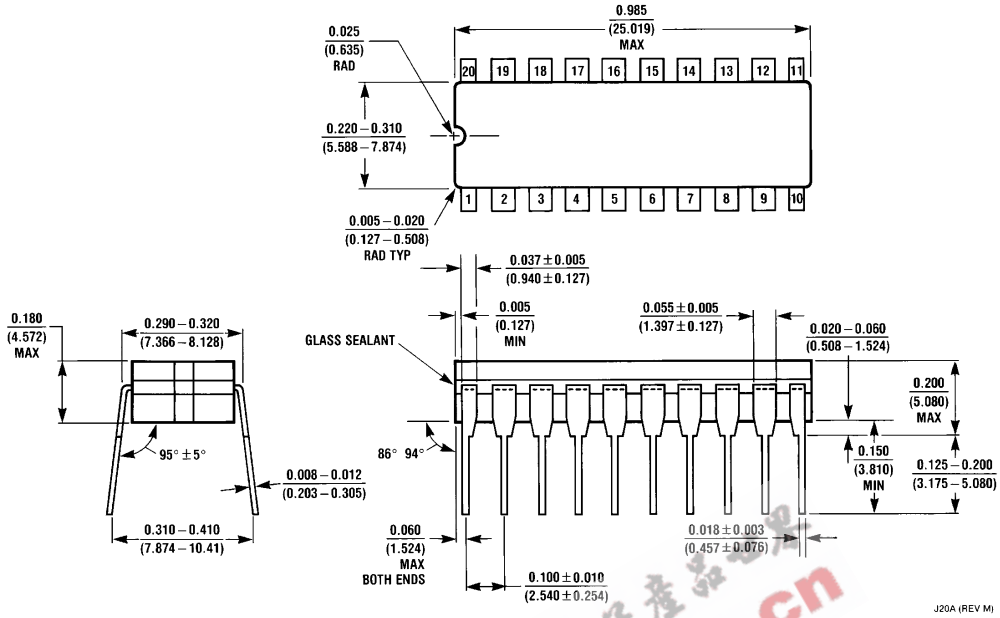

20-Lead Ceramic Dual-In-Line Package (D)
NS Package Number J20A

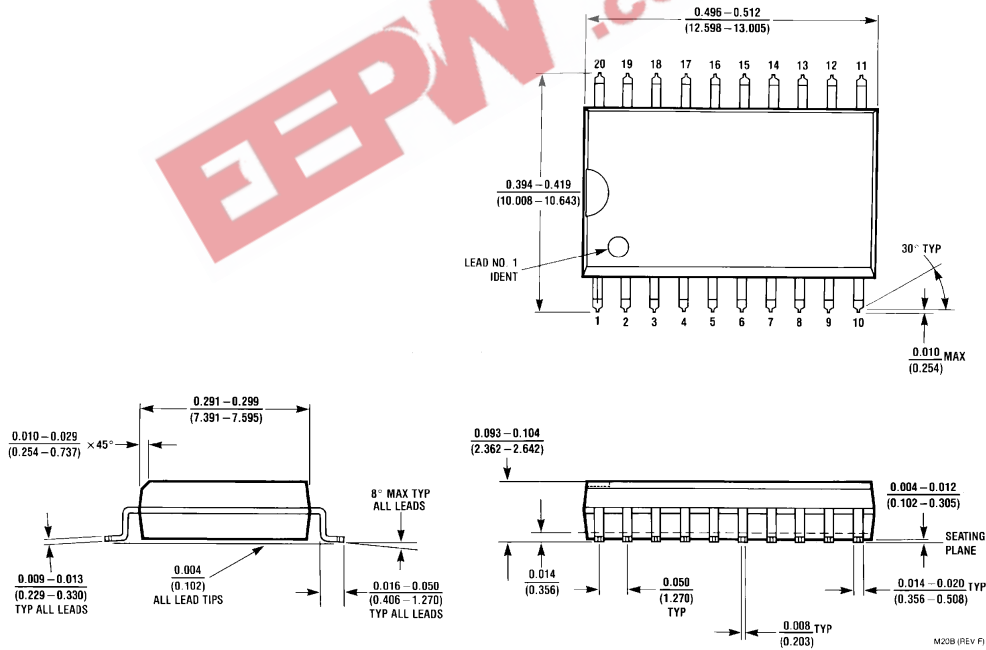

20-Lead (0.300" Wide) Molded Small Outline Package, JEDEC (S)
NS Package Number M20B

Physical Dimensions inches (millimeters) (Continued)

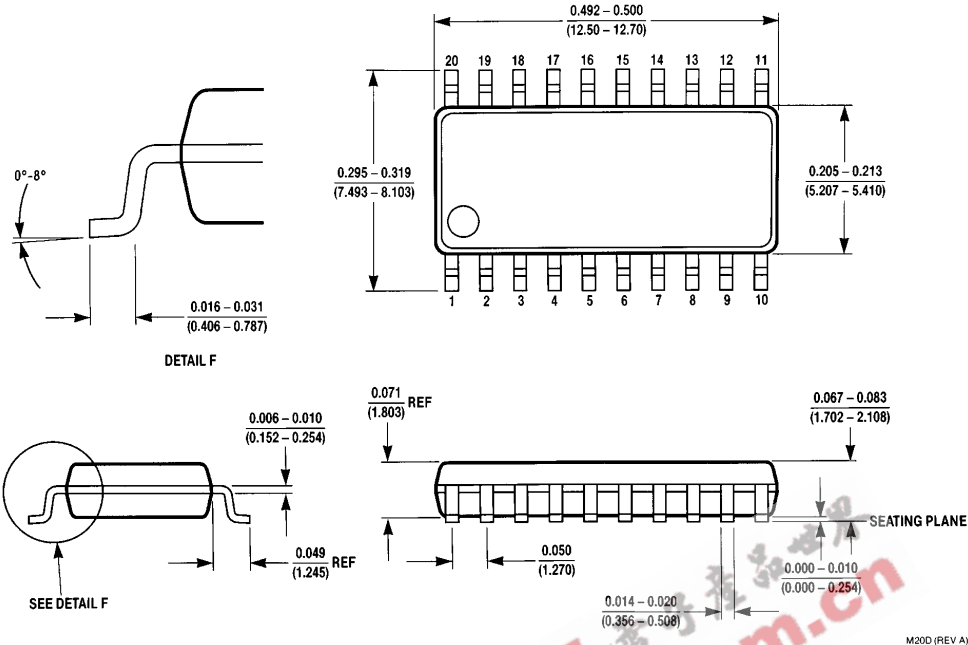

20-Lead (0.300" Wide) Molded Small Outline Package, EIAJ (SJ)
NS Package Number M20D

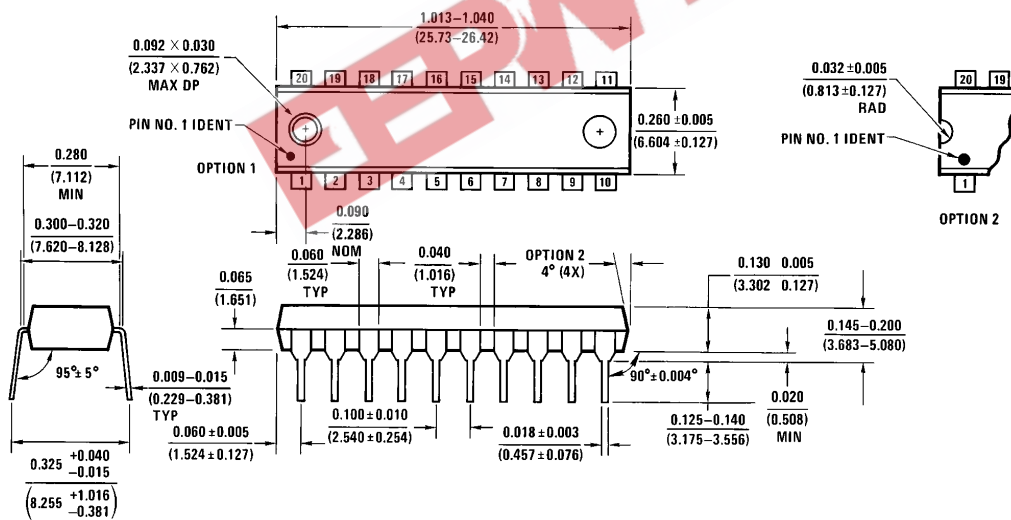

20-Lead (0.300" Wide) Molded Dual-In-Line Package (P)
NS Package Number N20A

Physical Dimensions inches (millimeters) (Continued)

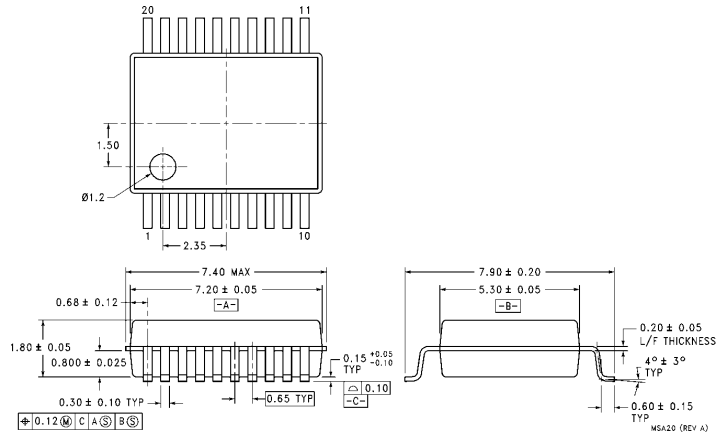

**20-Lead (0.300" Wide) Molded Shrink Outline Package, EIAJ, Type II (MSA)
NS Package Number MSA20**

EEPW.com.cn 电子产品世界

Physical Dimensions inches (millimeters) (Continued)

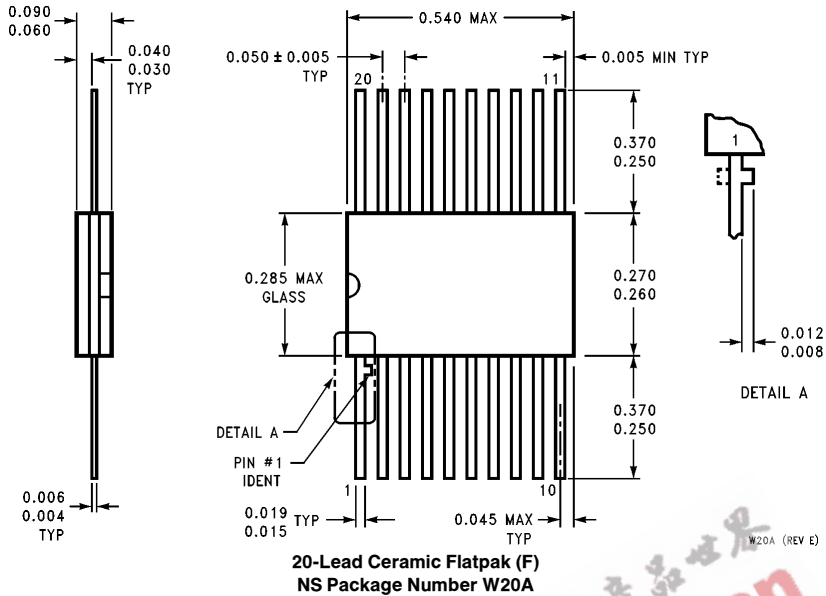

LIFE SUPPORT POLICY

NATIONAL'S PRODUCTS ARE NOT AUTHORIZED FOR USE AS CRITICAL COMPONENTS IN LIFE SUPPORT DEVICES OR SYSTEMS WITHOUT THE EXPRESS WRITTEN APPROVAL OF THE PRESIDENT OF NATIONAL SEMICONDUCTOR CORPORATION. As used herein:

1. Life support devices or systems are devices or systems which, (a) are intended for surgical implant into the body, or (b) support or sustain life, and whose failure to perform, when properly used in accordance with instructions for use provided in the labeling, can be reasonably expected to result in a significant injury to the user.
2. A critical component is any component of a life support device or system whose failure to perform can be reasonably expected to cause the failure of the life support device or system, or to affect its safety or effectiveness.



National Semiconductor Corporation
2900 Semiconductor Drive
P.O. Box 58090
Santa Clara, CA 95052-8090
Tel: 1 (800) 272-9959
TWX: (910) 339-9240

National Semiconductor GmbH
Livry-Gargan-Str. 10
D-82256 Fürstenfeldbruck
Germany
Tel: (81-41) 35-0
Telex: 527649
Fax: (81-41) 35-1

National Semiconductor Japan Ltd.
Sumitomo Chemical
Engineering Center
Bldg. 7F
1-7-1, Nakase, Mihama-Ku
Chiba-City,
Chiba Prefecture 261
Tel: (043) 299-2300
Fax: (043) 299-2500

National Semiconductor Hong Kong Ltd.
13th Floor, Straight Block,
Ocean Centre, 5 Canton Rd.
Tsimshatsui, Kowloon
Hong Kong
Tel: (852) 2737-1600
Fax: (852) 2736-9960

National Semiconductores Do Brazil Ltda.
Rua Deputado Lacorda Franco
120-3A
Sao Paulo-SP
Brazil 05418-000
Tel: (55-11) 212-5066
Telex: 391-1131931 NSBR BR
Fax: (55-11) 212-1181

National Semiconductor (Australia) Pty, Ltd.
Building 16
Business Park Drive
Monash Business Park
Nottingham, Melbourne
Victoria 3168 Australia
Tel: (3) 558-9889
Fax: (3) 558-9898