

DATA SHEET

EEPW 电子產品世界
.com.cn

74LVCU04A
Hex inverter

Product specification

1998 Jul 29

Hex inverter

74LVCU04A

FEATURES

- Wide supply voltage range of 1.2 V to 3.6 V
- In accordance with JEDEC standard no. 8-1A.
- Inputs accept voltages up to 5.5 V
- CMOS low power consumption
- Direct interface with TTL levels

DESCRIPTION

The 74LVCU04A is a high-performance, low-power, low-voltage, Si-gate CMOS device and superior to most advanced CMOS compatible TTL families.

The 74LVCU04A is a general purpose hex inverter. Each of the six inverters is a single stage with unbuffered outputs.

QUICK REFERENCE DATA

GND = 0 V; $T_{amb} = 25^{\circ}\text{C}$; $t_r = t_f \leq 2.5 \text{ ns}$

SYMBOL	PARAMETER	CONDITIONS	TYPICAL	UNIT
t_{PHL}/t_{PLH}	Propagation delay nA to nY	$C_L = 50 \text{ pF}$; $V_{CC} = 3.3 \text{ V}$	4.3	ns
C_I	Input capacitance		7.8	pF
C_{PD}	Power dissipation capacitance per gate	Notes 1 and 2	16.8	pF

NOTES:

- C_{PD} is used to determine the dynamic power dissipation (P_D in μW)
 $P_D = C_{PD} \times V_{CC}^2 \times f_i + \sum (C_L \times V_{CC}^2 \times f_o)$ where:
 f_i = input frequency in MHz; C_L = output load capacity in pF;
 f_o = output frequency in MHz; V_{CC} = supply voltage in V;
 $\sum (C_L \times V_{CC}^2 \times f_o)$ = sum of the outputs.
- The condition is $V_I = \text{GND to } V_{CC}$.

ORDERING INFORMATION

PACKAGES	TEMPERATURE RANGE	OUTSIDE NORTH AMERICA	NORTH AMERICA	PKG. DWG. #
14-Pin Plastic SO	$-40^{\circ}\text{C to } +85^{\circ}\text{C}$	74LVCU04A D	74LVCU04A D	SOT108-1
14-Pin Plastic SSOP Type II	$-40^{\circ}\text{C to } +85^{\circ}\text{C}$	74LVCU04A DB	74LVCU04A DB	SOT337-1
14-Pin Plastic TSSOP Type I	$-40^{\circ}\text{C to } +85^{\circ}\text{C}$	74LVCU04A PW	74LVCU04APW DH	SOT402-1

PIN CONFIGURATION

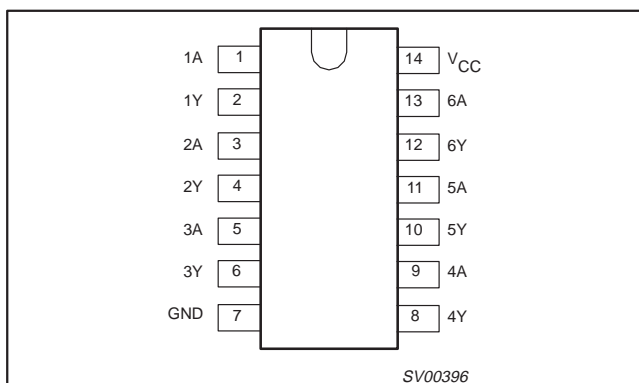

LOGIC SYMBOL (IEEE/IEC)

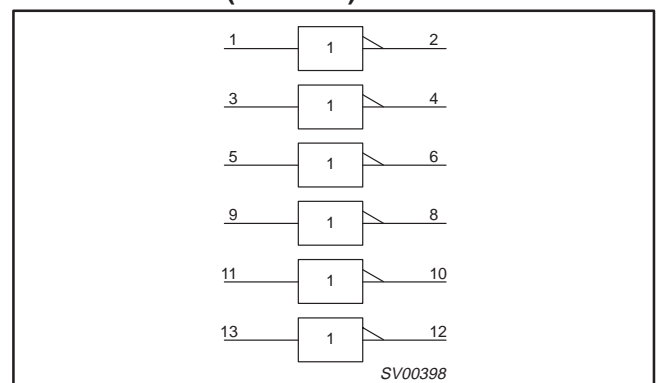

PIN DESCRIPTION

PIN NUMBER	SYMBOL	NAME AND FUNCTION
1, 3, 5, 9, 11, 13	1A – 6A	Data inputs
2, 4, 6, 8, 10, 12	1Y – 6Y	Data outputs
7	GND	Ground (0 V)
14	V_{CC}	Positive supply voltage

Hex inverter

74LVCU04A

LOGIC SYMBOL

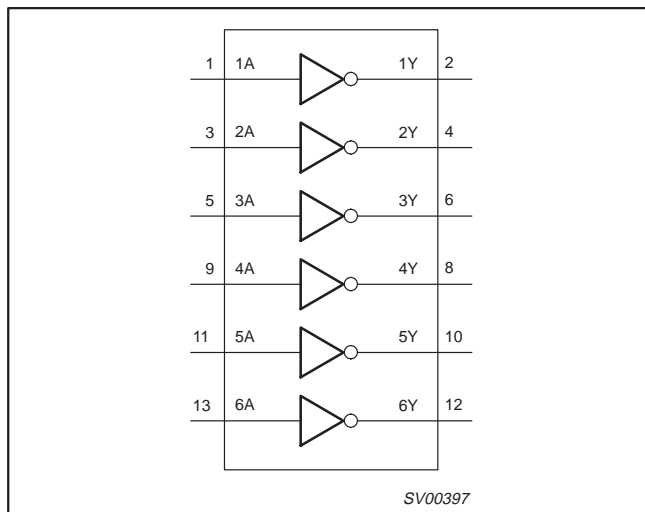

LOGIC DIAGRAM (ONE INVERTER)

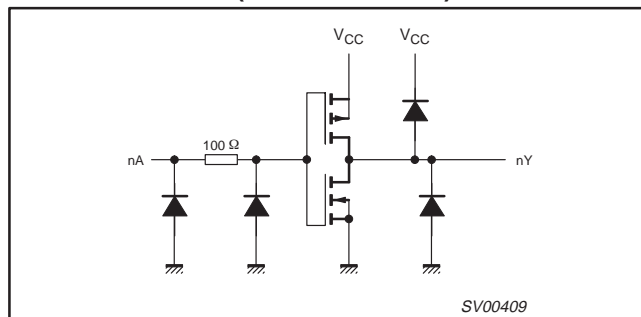

FUNCTION TABLE

INPUTS		OUTPUTS	
nA		nY	
L	H	H	L

NOTES:
 H = HIGH voltage level
 L = LOW voltage level

RECOMMENDED OPERATING CONDITIONS

SYMBOL	PARAMETER	CONDITIONS	LIMITS		UNIT
			MIN	MAX	
V_{CC}	DC supply voltage (for max. speed performance)		2.7	3.6	V
V_{CC}	DC supply voltage (for low-voltage applications)		1.2	3.6	V
V_I	DC input voltage range		0	5.5	V
$V_{I/O}$	DC output voltage range; output HIGH or LOW state		0	V_{CC}	V
	DC input voltage range; output 3-State		0	5.5	
T_{amb}	Operating free-air temperature range		-40	+85	°C
t_r, t_f	Input rise and fall times	$V_{CC} = 1.2$ to $2.7V$	0	20	ns/V
		$V_{CC} = 2.7$ to $3.6V$	0	10	

Hex inverter

74LVCU04A

ABSOLUTE MAXIMUM RATINGS¹

In accordance with the Absolute Maximum Rating System (IEC 134).

Voltages are referenced to GND (ground = 0V).

SYMBOL	PARAMETER	CONDITIONS	RATING	UNIT
V_{CC}	DC supply voltage		-0.5 to +6.5	V
I_{IK}	DC input diode current	$V_I < 0$	-50	mA
V_I	DC input voltage	Note 2	-0.5 to +6.5	V
I_{OK}	DC output diode current	$V_O > V_{CC}$ or $V_O < 0$	± 50	mA
$V_{I/O}$	DC output voltage; output HIGH or LOW	Note 2	-0.5 to $V_{CC} + 0.5$	V
	DC input voltage; output 3-State	Note 2	-0.5 to 6.5	
I_O	DC output source or sink current	$V_O = 0$ to V_{CC}	± 50	mA
I_{GND}, I_{CC}	DC V_{CC} or GND current		± 100	mA
T_{stg}	Storage temperature range		-65 to +150	°C
P_{TOT}	Power dissipation per package			
	- plastic mini-pack (SO) - plastic shrink mini-pack (SSOP and TSSOP)	above +70°C derate linearly with 8 mW/K above +60°C derate linearly with 5.5 mW/K	500 500	mW

NOTES:

- Stresses beyond those listed may cause permanent damage to the device. These are stress ratings only and functional operation of the device at these or any other conditions beyond those indicated under "recommended operating conditions" is not implied. Exposure to absolute-maximum-rated conditions for extended periods may affect device reliability.
- The input and output voltage ratings may be exceeded if the input and output current ratings are observed.

DC ELECTRICAL CHARACTERISTICS

Over recommended operating conditions. Voltages are referenced to GND (ground = 0V).

SYMBOL	PARAMETER	TEST CONDITIONS	LIMITS			UNIT
			Temp = -40°C to +85°C			
			MIN	TYP ¹	MAX	
V_{IH}	HIGH level Input voltage	$V_{CC} = 1.2$ V; $V_{OL(max)} = 0.5$ V; $I_O = -100$ μ A	V_{CC}			V
		$V_{CC} = 2.0$ V; $V_{OL(max)} = 0.5$ V; $I_O = -100$ μ A	1.2			
		$V_{CC} = 2.7$ V; $V_{OL(max)} = 0.5$ V; $I_O = -100$ μ A	1.8			
		$V_{CC} = 3.0$ V; $V_{OL(max)} = 0.5$ V; $I_O = -100$ μ A	2.0			
		$V_{CC} = 3.6$ V; $V_{OL(max)} = 0.5$ V; $I_O = -100$ μ A	2.4			
V_{IL}	LOW level Input voltage	$V_{CC} = 1.2$ V; $V_{OH(min)} = V_{CC} - 0.5$ V; $I_O = 100$ μ A			GND	V
		$V_{CC} = 2.0$ V; $V_{OH(min)} = V_{CC} - 0.5$ V; $I_O = 100$ μ A			0.6	
		$V_{CC} = 2.7$ V; $V_{OH(min)} = V_{CC} - 0.5$ V; $I_O = 100$ μ A			0.6	
		$V_{CC} = 3.0$ V; $V_{OH(min)} = V_{CC} - 0.5$ V; $I_O = 100$ μ A			1.0	
		$V_{CC} = 3.6$ V; $V_{OH(min)} = V_{CC} - 0.5$ V; $I_O = 100$ μ A			1.2	
V_{OH}	HIGH level output voltage	$V_{CC} = 2.7$ V; V_{CC} or GND; $I_O = -12$ mA	$V_{CC} - 0.5$			V
		$V_{CC} = 3.0$ V; V_{CC} or GND; $I_O = -100$ μ A	$V_{CC} - 0.2$	V_{CC}		
		$V_{CC} = 3.0$ V; V_{CC} or GND; $I_O = -12$ mA	$V_{CC} - 0.6$			
		$V_{CC} = 3.0$ V; V_{CC} or GND; $I_O = -24$ mA	$V_{CC} - 1.0$			
V_{OL}	LOW level output voltage	$V_{CC} = 2.7$ V; V_{CC} or GND; $I_O = 12$ mA			0.40	V
		$V_{CC} = 3.0$ V; V_{CC} or GND; $I_O = 12$ mA; $I_O = 100$ μ A			0.20	
		$V_{CC} = 3.0$ V; V_{CC} or GND; $I_O = 24$ mA			0.55	
I_I	Input leakage current	$V_{CC} = 3.6$ V; 5.5 V or GND; Not for I/O pins		± 0.1	± 5	μ A
I_{CC}	Quiescent supply current	$V_{CC} = 3.6$ V; V_{CC} or GND; $I_O = 0$		0.1	10	μ A

NOTE:

- All typical values are at $V_{CC} = 3.3$ V and $T_{amb} = 25$ °C.

Hex inverter

74LVCU04A

AC CHARACTERISTICS

GND = 0 V; $t_r = t_f \leq 2.5$ ns; $C_L = 50$ pF; $R_L = 500\Omega$; $T_{amb} = -40^\circ\text{C}$ to $+85^\circ\text{C}$

SYMBOL	PARAMETER	WAVEFORM	LIMITS						UNIT
			$V_{CC} = 3.3V \pm 0.3V$			$V_{CC} = 2.7V$		$V_{CC} = 1.2V$	
			MIN	TYP ¹	MAX	MIN	MAX	TYP	
t_{PHL}/t_{PLH}	Propagation delay nA to nY	Figure 1	-	2.7	4.3	-	5.3	-	ns

NOTE:

1. These typical values are at $V_{CC} = 3.3V$ and $T_{amb} = 25^\circ\text{C}$.

AC WAVEFORM

$V_M = 1.5$ V at $V_{CC} \geq 2.7$ V

$V_M = 0.5 \cdot V_{CC}$ at $V_{CC} < 2.7$ V

V_{OL} and V_{OH} are the typical output voltage drop that occur with the output load.

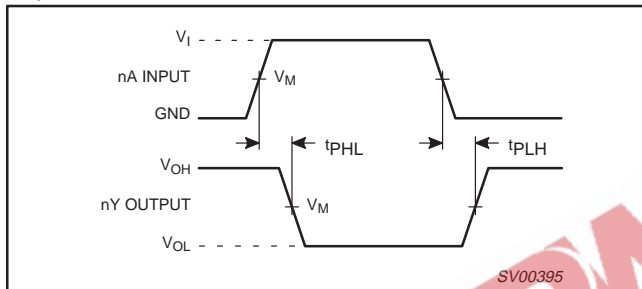

Figure 1. Input (nA) to output (nY) propagation delays.

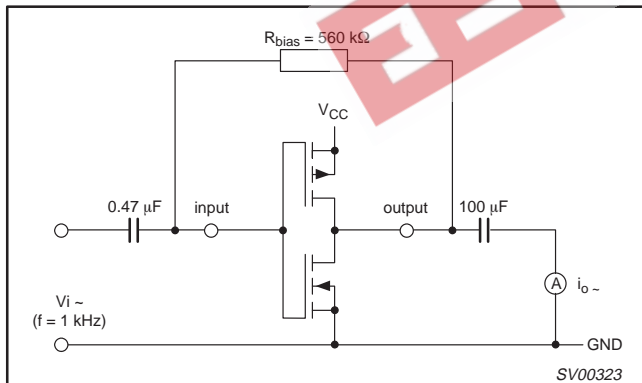

Figure 2. Test set-up for measuring forward transconductance $g_{fs} = di_o/dv_i$ at v_o is constant (see also graph Figure 3).

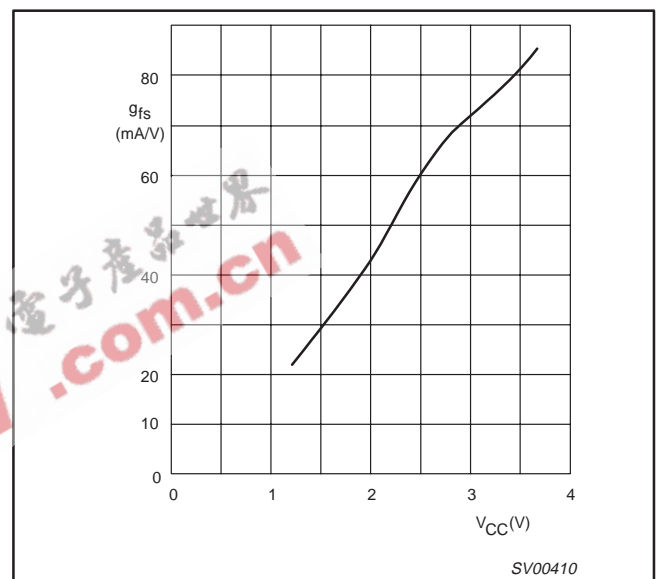

Figure 3. Typical forward transconductance g_{fs} as a function of the supply voltage V_{CC} at $T_{amb} = 25^\circ\text{C}$.

Hex inverter

74LVCU04A

APPLICATION INFORMATION

Some applications for the 74LVU04 are:

- Linear amplifier (see Figure 4)
- In crystal oscillator designs (see Figure 5)
- Astable multivibrator (see Figure 6)

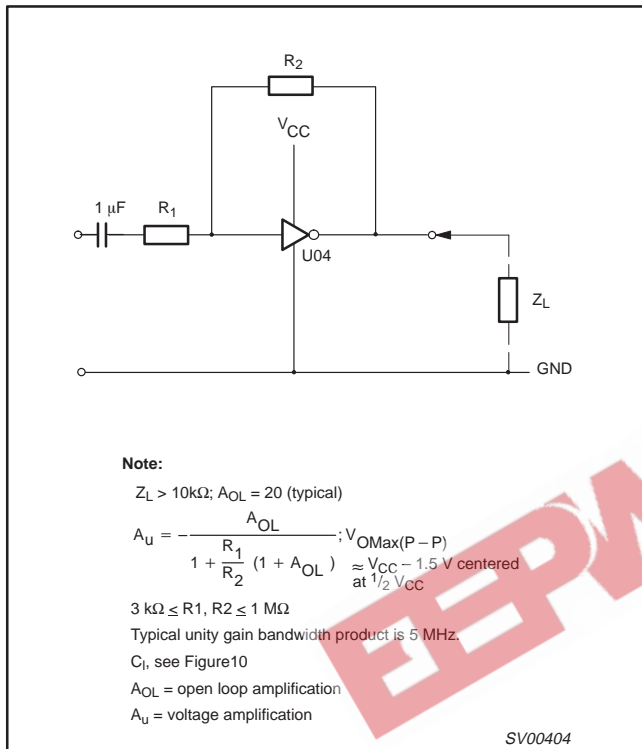

Figure 4. LVU04 used as a linear amplifier.

Note to Figure 4

$Z_L > 10\text{ k}\Omega$; $A_{OL} = 20$ (typical)

$$A_u = -\frac{A_{OL}}{1 + \frac{R_1}{R_2}(1 + A_{OL})}; V_{O\text{Max(P-P)}} \approx V_{CC} - 1.5\text{ V centered at } 1/2 V_{CC}$$

$3\text{ k}\Omega \leq R_1, R_2 \leq 1\text{ M}\Omega$

Typical unity gain bandwidth product is 50 MHz.

A_{OL} = open loop amplification

A_u = voltage amplification

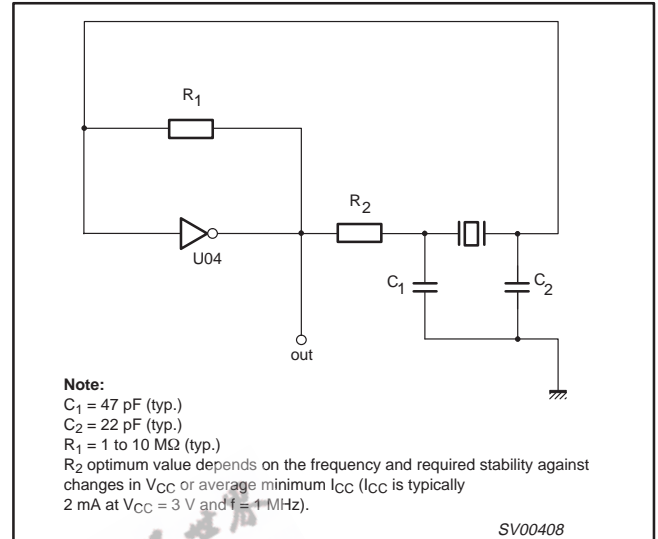

Figure 5. Crystal oscillator configuration.

Note to Figure 5

$C_1 = 47\text{ pF}$ (typ.)

$C_2 = 22\text{ pF}$ (typ.)

$R_1 = 1\text{ to }10\text{ M}\Omega$ (typ.)

R_2 optimum value depends on the frequency and required stability against changes in V_{CC} or average minimum I_{CC} .

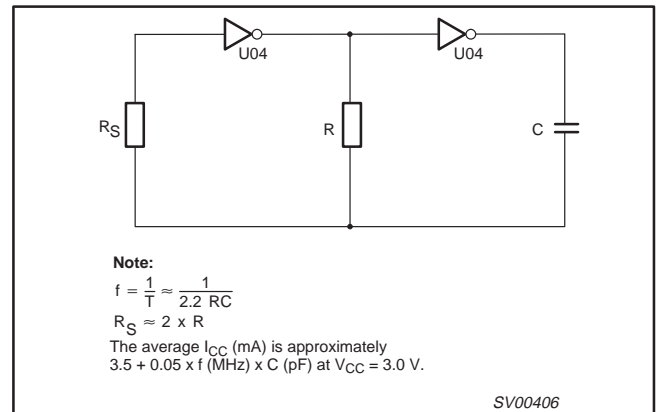

Figure 6. LVCU04 used as an astable multivibrator.

Note to Figure 6

$$f = \frac{1}{T} \approx \frac{1}{2.2 RC}$$

$R_S \approx 2 \times R$

Hex inverter

74LVCU04A

SO14: plastic small outline package; 14 leads; body width 3.9 mm

SOT108-1

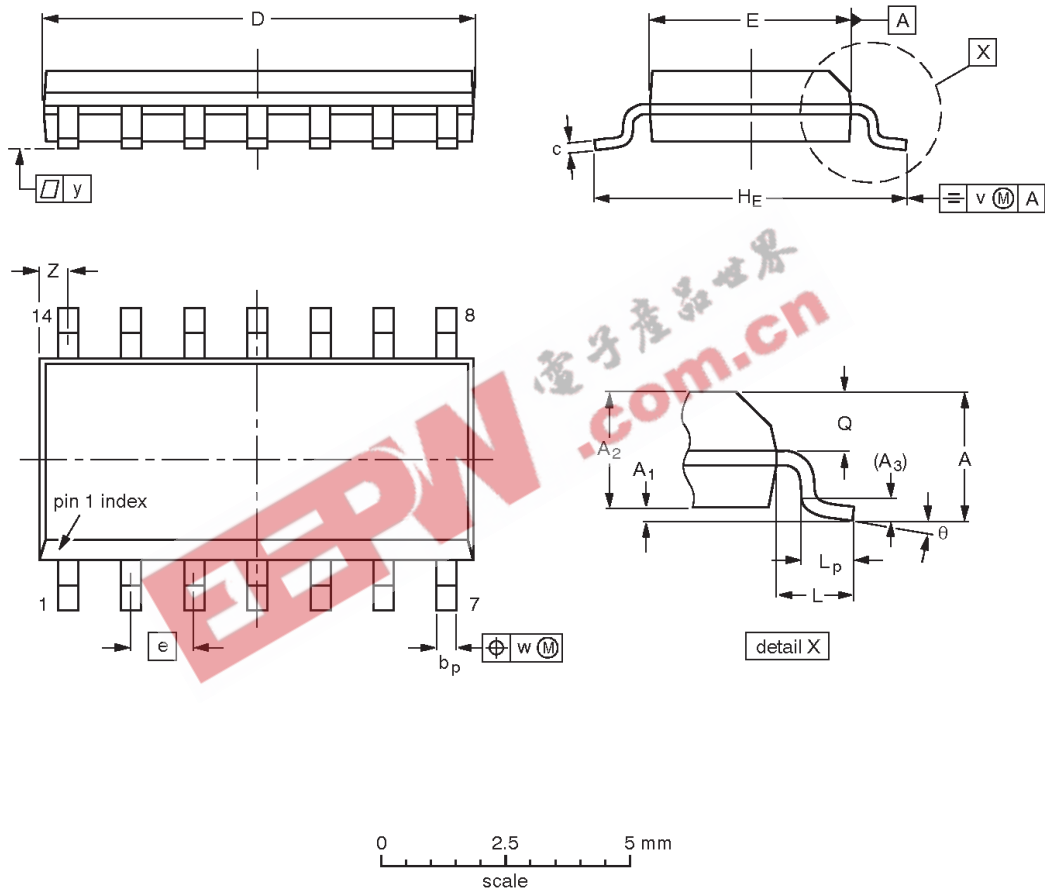

DIMENSIONS (inch dimensions are derived from the original mm dimensions)

UNIT	A max.	A ₁	A ₂	A ₃	b _p	c	D ⁽¹⁾	E ⁽¹⁾	e	H _E	L	L _p	Q	v	w	y	Z ⁽¹⁾	θ
mm	1.75	0.25 0.10	1.45 1.25	0.25	0.49 0.36	0.25 0.19	8.75 8.55	4.0 3.8	1.27	6.2 5.8	1.05	1.0 0.4	0.7 0.6	0.25	0.25	0.1	0.7 0.3	8° 0°
inches	0.069	0.010 0.004	0.057 0.049	0.01	0.019 0.014	0.0100 0.0075	0.35 0.34	0.16 0.15	0.050	0.244 0.228	0.041	0.039 0.016	0.028 0.024	0.01	0.01	0.004	0.028 0.012	

Note

1. Plastic or metal protrusions of 0.15 mm maximum per side are not included.

OUTLINE VERSION	REFERENCES				EUROPEAN PROJECTION	ISSUE DATE
	IEC	JEDEC	EIAJ			
SOT108-1	076E06S	MS-012AB				95-01-20 97-05-22

Hex inverter

74LVCU04A

SSOP14: plastic shrink small outline package; 14 leads; body width 5.3 mm

SOT337-1

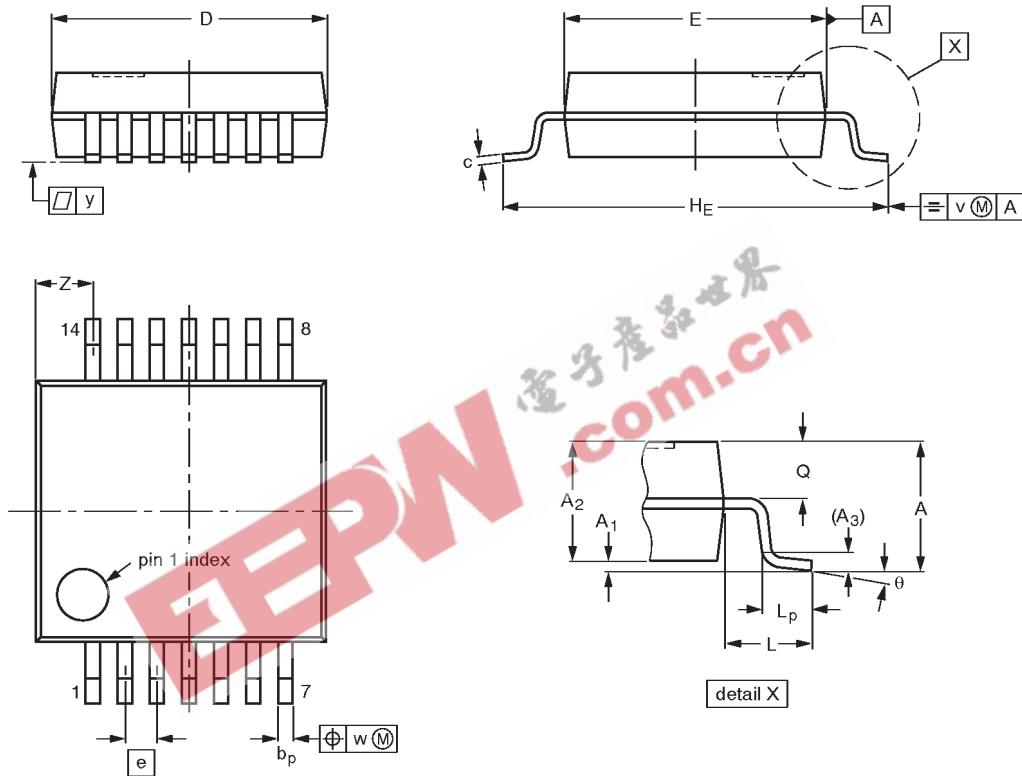

DIMENSIONS (mm are the original dimensions)

UNIT	A max.	A ₁	A ₂	A ₃	b _p	c	D ⁽¹⁾	E ⁽¹⁾	e	H _E	L	L _p	Q	v	w	y	Z ⁽¹⁾	θ
mm	2.0	0.21 0.05	1.80 1.65	0.25	0.38 0.25	0.20 0.09	6.4 6.0	5.4 5.2	0.65	7.9 7.6	1.25	1.03 0.63	0.9 0.7	0.2	0.13	0.1	1.4 0.9	8° 0°

Note

1. Plastic or metal protrusions of 0.25 mm maximum per side are not included.

OUTLINE VERSION	REFERENCES				EUROPEAN PROJECTION	ISSUE DATE
	IEC	JEDEC	EIAJ			
SOT337-1		MO-150AB				95-02-04 96-01-18

Hex inverter

74LVCU04A

TSSOP14: plastic thin shrink small outline package; 14 leads; body width 4.4 mm

SOT402-1

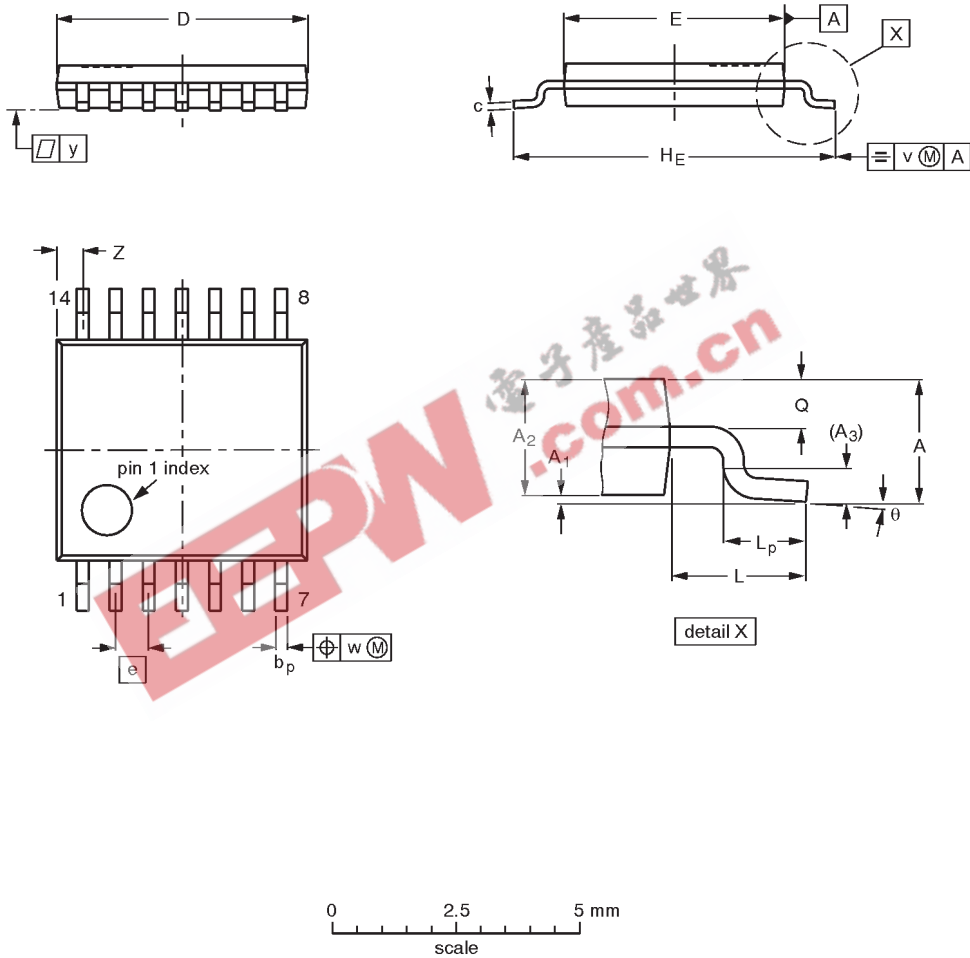

DIMENSIONS (mm are the original dimensions)

UNIT	A max.	A ₁	A ₂	A ₃	b _p	c	D ⁽¹⁾	E ⁽²⁾	e	H _E	L	L _p	Q	v	w	y	Z ⁽¹⁾	θ
mm	1.10	0.15 0.05	0.95 0.80	0.25	0.30 0.19	0.2 0.1	5.1 4.9	4.5 4.3	0.65	6.6 6.2	1.0	0.75 0.50	0.4 0.3	0.2	0.13	0.1	0.72 0.38	8° 0°

Notes

1. Plastic or metal protrusions of 0.15 mm maximum per side are not included.
2. Plastic interlead protrusions of 0.25 mm maximum per side are not included.

OUTLINE VERSION	REFERENCES				EUROPEAN PROJECTION	ISSUE DATE
	IEC	JEDEC	EIAJ			
SOT402-1		MO-153				-94-07-12- 95-04-04

Hex inverter

74LVCU04A

Data sheet status

Data sheet status	Product status	Definition [1]
Objective specification	Development	This data sheet contains the design target or goal specifications for product development. Specification may change in any manner without notice.
Preliminary specification	Qualification	This data sheet contains preliminary data, and supplementary data will be published at a later date. Philips Semiconductors reserves the right to make changes at any time without notice in order to improve design and supply the best possible product.
Product specification	Production	This data sheet contains final specifications. Philips Semiconductors reserves the right to make changes at any time without notice in order to improve design and supply the best possible product.

[1] Please consult the most recently issued datasheet before initiating or completing a design.

Definitions

Short-form specification — The data in a short-form specification is extracted from a full data sheet with the same type number and title. For detailed information see the relevant data sheet or data handbook.

Limiting values definition — Limiting values given are in accordance with the Absolute Maximum Rating System (IEC 134). Stress above one or more of the limiting values may cause permanent damage to the device. These are stress ratings only and operation of the device at these or at any other conditions above those given in the Characteristics sections of the specification is not implied. Exposure to limiting values for extended periods may affect device reliability.

Application information — Applications that are described herein for any of these products are for illustrative purposes only. Philips Semiconductors make no representation or warranty that such applications will be suitable for the specified use without further testing or modification.

Disclaimers

Life support — These products are not designed for use in life support appliances, devices or systems where malfunction of these products can reasonably be expected to result in personal injury. Philips Semiconductors customers using or selling these products for use in such applications do so at their own risk and agree to fully indemnify Philips Semiconductors for any damages resulting from such application.

Right to make changes — Philips Semiconductors reserves the right to make changes, without notice, in the products, including circuits, standard cells, and/or software, described or contained herein in order to improve design and/or performance. Philips Semiconductors assumes no responsibility or liability for the use of any of these products, conveys no license or title under any patent, copyright, or mask work right to these products, and makes no representations or warranties that these products are free from patent, copyright, or mask work right infringement, unless otherwise specified.

Philips Semiconductors
811 East Arques Avenue
P.O. Box 3409
Sunnyvale, California 94088-3409
Telephone 800-234-7381

© Copyright Philips Electronics North America Corporation 1998
All rights reserved. Printed in U.S.A.

print code

Date of release: 07-98

Document order number:

9397-750-04479

Let's make things better.