



FOUR-BIT UP/DOWN COUNTER WITH THREE-STATE OUTPUTS

The SN54/74LS569A is designed as programmable up/down BCD and Binary counters respectively. These devices have 3-state outputs for use in bus organized systems. With the exception of output enable (OE) and asynchronous clear (ACLR), all functions occur on the positive edge of the clock pulse (CP).

When the LOAD input is LOW, the outputs will be programmed by the parallel data inputs (A, B, C, D) on the next clock edge. Enabling of the counters occurs only when CEP and CET are LOW and LOAD is HIGH. Direction of the count is controlled by the up-down input (U/D), HIGH counts up and LOW counts down. High-speed counting and cascading is implemented by internal look-ahead carry logic and an active LOW ripple carry output (RCO). On the LS569A, the RCO is LOW at binary 15 during up-count and during down-count it is also LOW at binary 0. During normal cascading operation RCO connected to the succeeding block at CET is the only requisite. When counting and when RCO is LOW, the clocked carry output (CCO) provides a HIGH-LOW-HIGH pulse for a duration equal to the LOW time of the clock pulse. Two active LOW reset lines are provided, a master reset asynchronous clear (ACLR) and a synchronous clear (SCLR). When in a HIGH state, the output control (OE) input forces the counter output into a HIGH impedance state and when LOW, the counter outputs are enabled.

- ESD > 3500 Volts

CONNECTION DIAGRAM (TOP VIEW)

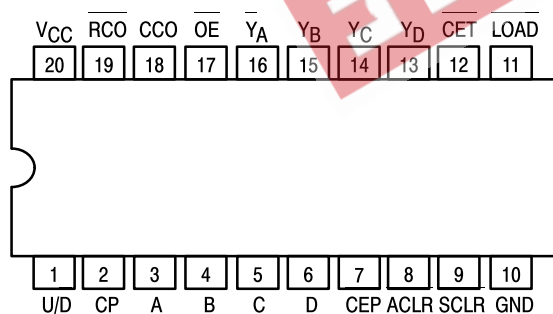

VCC = PIN 20
GND = PIN 10

Note: Pin 1 is marked for orientation.

SN54/74LS569A

FOUR-BIT UP/DOWN COUNTER WITH THREE-STATE OUTPUTS

LOW POWER SCHOTTKY

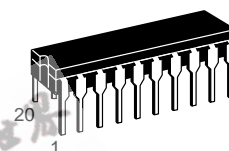

J SUFFIX
CERAMIC
CASE 732-03

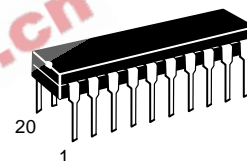

N SUFFIX
PLASTIC
CASE 738-03

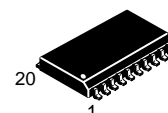

DW SUFFIX
SOIC
CASE 751D-03

ORDERING INFORMATION

SN54LSXXXJ Ceramic
SN74LSXXXN Plastic
SN74LSXXXDW SOIC

GUARANTEED OPERATING RANGES

| Symbol | Parameter | | Min | Typ | Max | Unit |
|--------|---------------------------------------|--------|------|-----|-------|------|
| VCC | Supply Voltage | 54 | 4.5 | 5.0 | 5.5 | V |
| | | 74 | 4.75 | 5.0 | 5.25 | |
| TA | Operating Ambient Temperature Range | 54 | -55 | 25 | 125 | °C |
| | | 74 | 0 | 25 | 70 | |
| IOH | Output Current — High Except RCO, CCO | 54 | | | -1.0 | mA |
| | | 74 | | | -2.6 | |
| IOH | Output Current — High RCO, CCO | 54, 74 | | | -0.44 | mA |
| IOL | Output Current — Low Except RCO, CCO | 54 | | | 12 | mA |
| | | 74 | | | 24 | |
| IOL | Output Current — Low, RCO, CCO | 54 | | | 4.0 | mA |
| | | 74 | | | 8.0 | |

SN54/74LS569A

FUNCTION TABLE

| INPUTS | | | | | | | | | | | OUTPUTS | | | | | | | | |
|--------|---|---|---|---|------|-----|-----|-----|------|------|---------|-----|-----|------------------|----------------|----------------|----------------|-----------------|---------------------|
| CP | D | C | B | A | LOAD | CET | CEP | U/D | ACLR | SCLR | OE | RCO | CCO | Y _D | Y _C | Y _B | Y _A | | |
| ↑ | X | X | X | X | H | L | L | H | H | H | L | A/R | A/R | $(Q_T - CP) + 1$ | | | | Count Up | |
| ↑ | X | X | X | X | H | L | L | L | H | H | L | A/R | A/R | $(Q_T - CP) - 1$ | | | | Count Down | |
| ↑ | X | X | X | X | H | H | X | X | H | H | L | H | H | NC | NC | NC | NC | NC | Count Inhibit |
| ↑ | X | X | X | X | H | L | H | X | H | H | L | A/R | H | NC | NC | NC | NC | NC | Count Inhibit |
| Ω | X | X | X | X | X | L | L | H | H | H | L | L | ∅ | H | H | H | H | H | Overflow |
| ↑ | X | X | X | X | X | L | H | H | H | H | L | L | H | H | H | H | H | H | Overflow |
| ↑ | X | X | X | X | X | H | X | H | H | H | L | H | H | H | H | H | H | H | Overflow Inhibit |
| ∅ | X | X | X | X | X | L | L | L | H | H | L | L | ∅ | L | L | L | L | L | Underflow |
| ↑ | X | X | X | X | X | L | H | L | H | H | L | L | H | L | L | L | L | L | Underflow |
| ↑ | X | X | X | X | X | H | X | L | H | H | L | H | H | L | L | L | L | L | Underflow Inhibit |
| ↑ | L | H | L | H | L | X | X | X | H | H | L | H | H | L | H | L | H | H | Load Example |
| ↑ | X | X | X | X | X | H | X | H | H | L | L | H | H | L | L | L | L | L | Clear (Synchronous) |
| ∅ | X | X | X | X | X | L | L | L | H | L | L | L | ∅ | L | L | L | L | L | Clear (Synchronous) |
| ↑ | X | X | X | X | X | L | H | L | H | L | L | L | H | L | L | L | L | L | Clear (Synchronous) |
| ↑ | X | X | X | X | X | H | X | L | H | L | L | H | H | L | L | L | L | L | Clear (Synchronous) |
| X | X | X | X | X | X | X | X | H | L | X | L | H | H | L | L | L | L | L | Asynchronous Clear |
| ∅ | X | X | X | X | X | L | L | L | L | X | L | L | ∅ | L | L | L | L | L | Asynchronous Clear |
| X | X | X | X | X | X | L | H | L | L | X | L | L | H | L | L | L | L | L | Asynchronous Clear |
| X | X | X | X | X | X | H | X | L | L | X | L | H | H | L | L | L | L | L | Asynchronous Clear |
| X | X | X | X | X | X | X | X | X | X | X | H | X | X | Hi-Z | | | | Output Disabled | |

$(Q_T - CP)$ = Output state prior to clock edge
 NC = No change

A/R = Assumes required output state;
 High except during Overflow and Underflow

X = Don't care

LOGIC DIAGRAM

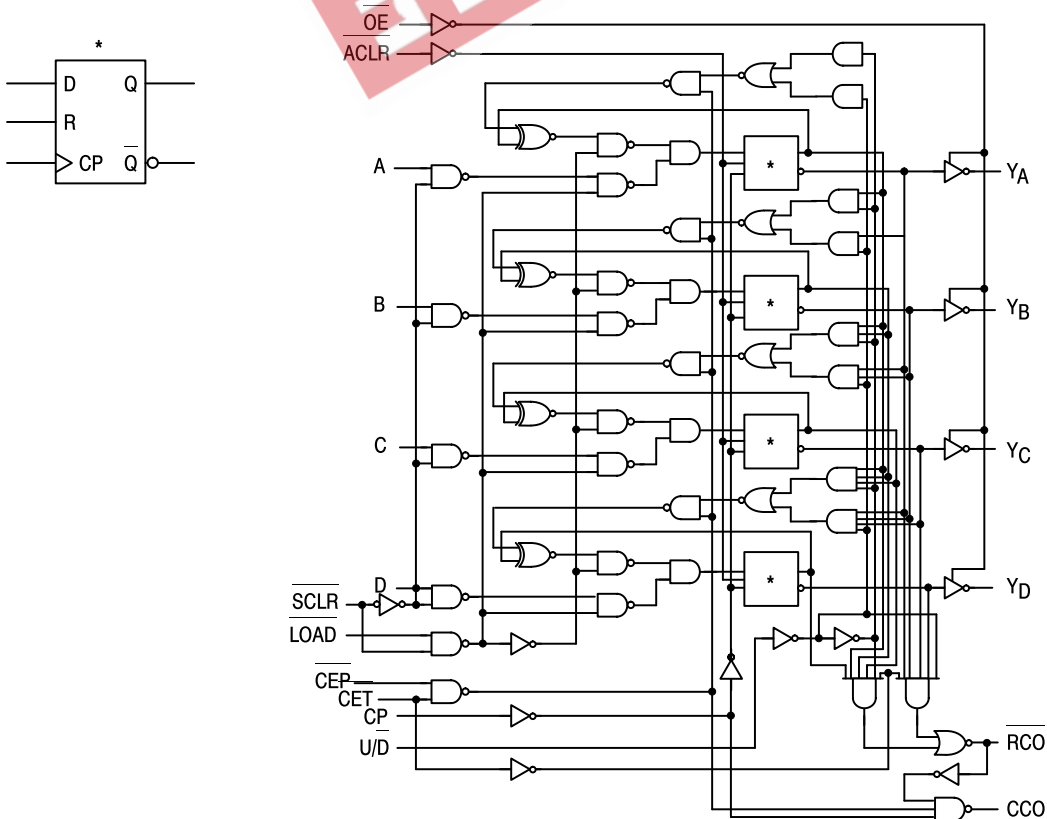

SN54/74LS569A

DEFINITION OF FUNCTIONAL TERMS

| | | | |
|--------------------------|---|---|--|
| A, B, C, D | The four programmable data inputs. | $\overline{\text{ACLR}}$ | Asynchronous Clear. <u>Master</u> reset of counters to zero when ACLR is LOW, independent of the clock. |
| $\overline{\text{CEP}}$ | Count Enable Parallel. Can be used to enable and inhibit counting in high speed cascaded operation. CEP must be LOW to count. | $\overline{\text{SCLR}}$ | Synchronous clear of counters to zero on the next clock edge when SCLR is LOW. |
| $\overline{\text{CET}}$ | Count Enable Trickle. Enables the ripple carry output for cascaded operation. Must be LOW to count. | $\overline{\text{OE}}$ | A HIGH on the output control sets the four counter outputs in the high impedance, and a LOW, enables the output. |
| CP | Clock Pulse. All synchronous functions occur on the LOW-to-HIGH transition of the clock. | Y _A , Y _B , Y _C , Y _D | The four counter outputs. |
| $\overline{\text{LOAD}}$ | Enables parallel load of counter outputs from data inputs on the next clock edge. Must be HIGH to count. | $\overline{\text{RCO}}$ | Ripple Carry Output. Output will be LOW on the maximum count on up-count. Upon down-count, RCO is LOW at 0000. |
| $\overline{\text{U/D}}$ | Up/Down Count Control. HIGH counts up and LOW counts down. | CCO | Clock Carry Output. While counting and RCO is LOW, CCO will follow the clock HIGH-LOW-HIGH transition. |

LOW-POWER SCHOTTKY INPUT/OUTPUT CURRENT INTERFACE CONDITIONS

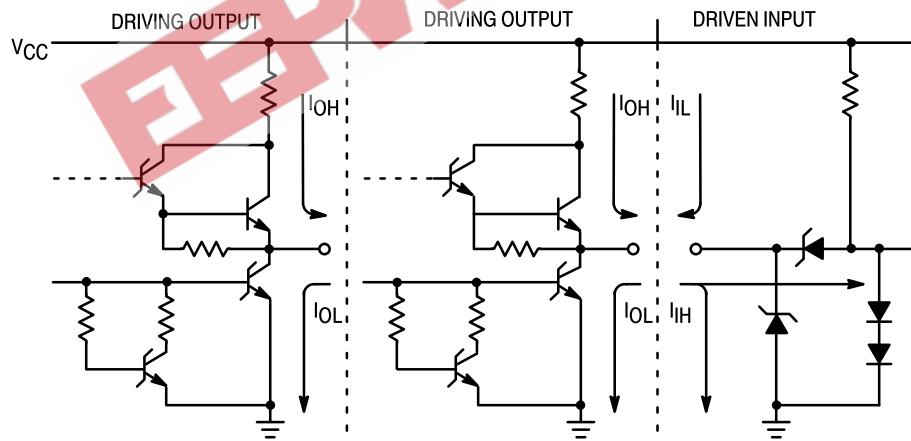

Note: Actual current flow direction shown

SN54/74LS569A

DC CHARACTERISTICS OVER OPERATING TEMPERATURE RANGE (unless otherwise specified)

| Symbol | Parameter | | Limits | | | Unit | Test Conditions |
|------------------|--------------------------------|----------|--------|-------|------|------|--|
| | | | Min | Typ | Max | | |
| V _{IH} | Input HIGH Voltage | | 2.0 | | | V | Guaranteed Input HIGH Voltage for All Inputs |
| V _{IL} | Input LOW Voltage | 54 | | | 0.7 | V | Guaranteed Input LOW Voltage for All Inputs |
| | | 74 | | | 0.8 | | |
| V _{IK} | Input Clamp Diode Voltage | | | -0.65 | -1.5 | V | V _{CC} = MIN, I _{IN} = -18 mA |
| V _{OH} | Output HIGH Voltage | YA-YD | 54 | 2.4 | 3.4 | V | V _{CC} = MIN, I _{OH} = MAX, V _{IN} = V _{IH} or V _{IL} per Truth Table |
| | | | 74 | 2.4 | 3.1 | V | |
| | RCO, CCO | 54 | 2.5 | 3.5 | V | | |
| | | 74 | 2.7 | 3.5 | V | | |
| V _{OL} | Output LOW Voltage | 54, 74 | | 0.25 | 0.4 | V | I _{OL} = I _{OL} MAX V _{CC} = V _{CC} MIN, V _{IN} = V _{IL} or V _{IH} per Truth Table |
| | | 74 | | 0.35 | 0.5 | V | |
| I _{OZH} | Output Off Current HIGH | | | | 20 | μA | V _{CC} = MAX, V _O = 2.7 V |
| I _{OZL} | Output Off Current LOW | | | | -20 | μA | V _{CC} = MAX, V _O = 0.4 V |
| I _{IH} | Input HIGH Current | | | | 20 | μA | V _{CC} = MAX, V _{IN} = 2.7 V |
| | | | | | 0.1 | mA | V _{CC} = MAX, V _{IN} = 7.0 V |
| I _{IL} | Input LOW Current | Others | | | -0.4 | mA | V _{CC} = MAX, V _{IN} = 0.4 V |
| | | CET | | | -0.8 | mA | |
| I _{OS} | Short Circuit Current (Note 1) | RCO, CCO | -20 | | -100 | mA | V _{CC} = MAX |
| | | Others | -30 | | -130 | mA | |
| I _{CC} | Power Supply Current, 3-State | | | | 43 | mA | V _{CC} = MAX |

Note 1: Not more than one output should be shorted at a time, nor for more than 1 second.

AC CHARACTERISTICS (T_A = 25°C)

| Symbol | Parameter | | Limits | | | Unit | Test Conditions |
|--------|-----------|--|--------|-----|-----|------|-----------------|
| | | | Min | Typ | Max | | |

| | | | | | | |
|--------------------------------------|-----------------------------------|----|--|----------|-----|---|
| f _{MAX} | Maximum Toggle Frequency | 35 | | | MHz | V _{CC} = 5.0 V C _L = 45 pF R _L = 667 Ω |
| t _{PLH} t _{PHL} | Propagation Delay Clock to Q | | | 15 20 | ns | |
| t _{PLH} t _{PHL} | Propagation Delay CET to RCO | | | 14 15 | ns | |
| t _{PLH} t _{PHL} | Propagation Delay U/D to RCO | | | 20 24 | ns | |
| t _{PLH} t _{PHL} | Propagation Delay Clock to RCO | | | 20 25 | ns | |
| t _{PLH} t _{PHL} | Propagation Delay CET to CCO | | | 16 28 | ns | |
| t _{PLH} t _{PHL} | Propagation Delay CEP to CCO | | | 16 26 | ns | |
| t _{PLH} t _{PHL} | Propagation Delay Clock to CCO | | | 15 17 | ns | |
| t _{PLH} t _{PHL} | Propagation Delay ACLR to Q | | | 22 32 | ns | |
| t _{PZH} t _{PZL} | Output Enable Time | | | 15 20 | ns | |
| t _{PHZ} t _{PLZ} | Output Disable Time | | | 20 27 | ns | |

V_{CC} = 5.0 V
C_L = 45 pF
R_L = 667 Ω

C_L = 5.0 pF

EEPW.com.cn 电子产品世界

SN54/74LS569A

AC SETUP REQUIREMENTS ($T_A = 25^\circ\text{C}$, $V_{CC} = 5.0\text{ V}$)

| Symbol | Parameter | Limits | | | Unit | Test Conditions |
|-----------|-------------------------|--------|-----|-----|------|-------------------------|
| | | Min | Typ | Max | | |
| t_W | Clock Pulse Width (Low) | 20 | | | ns | $V_{CC} = 5.0\text{ V}$ |
| t_S | Setup Time, A, B, C, D | 20 | | | ns | |
| t_S | Setup Time, SCLR | 20 | | | ns | |
| t_S | Setup Time, LOAD | 25 | | | ns | |
| t_S | Setup Time, U/D | 30 | | | ns | |
| t_S | Setup Time, CET, CEP | 20 | | | ns | |
| t_H | Hold Time, Any Inputs | 0 | | | ns | |
| t_{rec} | ACLR | 15 | | | ns | |

MICROPROGRAMMABLE DUAL-EVENT 8-BIT COUNTERS

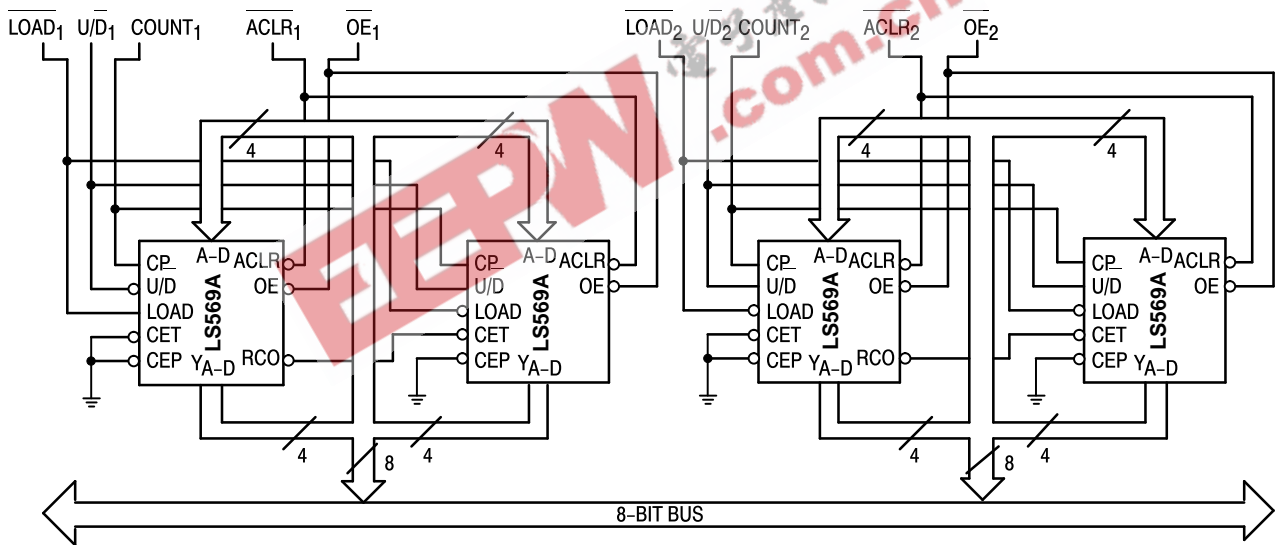

**Case 751D-03 DW Suffix
20-Pin Plastic
SO-20 (WIDE)**

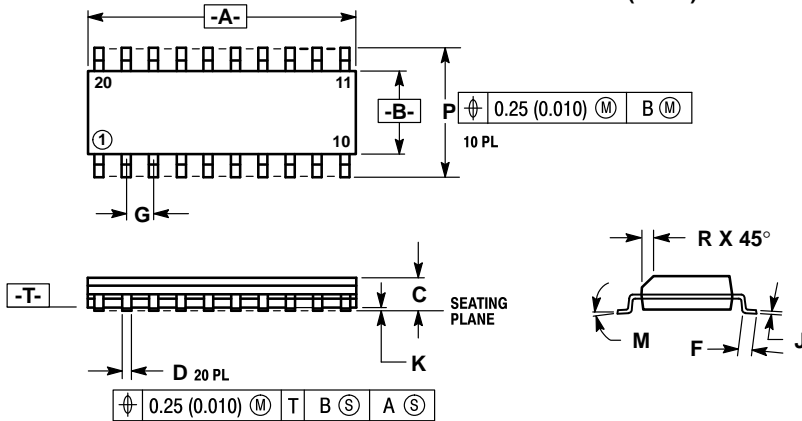

NOTES:

1. DIMENSIONING AND TOLERANCING PER ANSI Y14.5M, 1982.
2. CONTROLLING DIMENSION: MILLIMETER.
3. DIMENSION A AND B DO NOT INCLUDE MOLD PROTRUSION.
4. MAXIMUM MOLD PROTRUSION 0.15 (0.006) PER SIDE.
5. 751D-01, AND -02 OBSOLETE, NEW STANDARD 751D-03.

| DIM | MILLIMETERS | | INCHES | |
|-----|-------------|-------|-----------|-------|
| | MIN | MAX | MIN | MAX |
| A | 12.65 | 12.95 | 0.499 | 0.510 |
| B | 7.40 | 7.60 | 0.292 | 0.299 |
| C | 2.35 | 2.65 | 0.093 | 0.104 |
| D | 0.35 | 0.49 | 0.014 | 0.019 |
| F | 0.50 | 0.90 | 0.020 | 0.035 |
| G | 1.27 BSC | | 0.050 BSC | |
| J | 0.25 | 0.32 | 0.010 | 0.012 |
| K | 0.10 | 0.25 | 0.004 | 0.009 |
| M | 0° | 7° | 0° | 7° |
| P | 10.05 | 10.55 | 0.395 | 0.415 |
| R | 0.25 | 0.75 | 0.010 | 0.029 |

**Case 732-03 J Suffix
20-Pin Ceramic Dual In-Line**

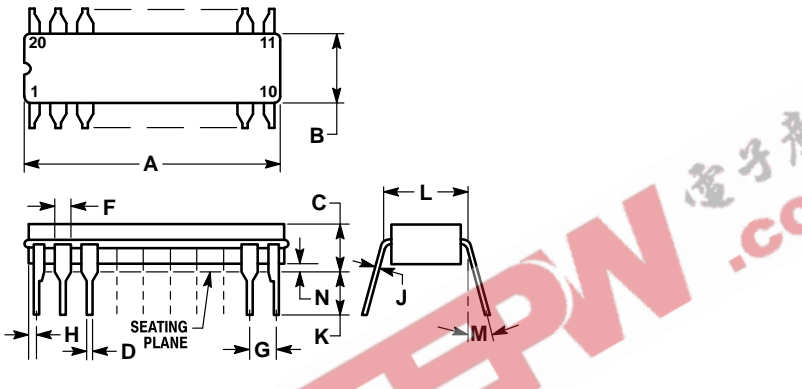

NOTES:

1. LEADS WITHIN 0.25 mm (0.010) DIA., TRUE POSITION AT SEATING PLANE, AT MAXIMUM MATERIAL CONDITION.
2. DIM L TO CENTER OF LEADS WHEN FORMED PARALLEL.
3. DIM A AND B INCLUDES MENISCUS.

| DIM | MILLIMETERS | | INCHES | |
|-----|-------------|-------|-----------|-------|
| | MIN | MAX | MIN | MAX |
| A | 23.88 | 25.15 | 0.940 | 0.990 |
| B | 6.60 | 7.49 | 0.260 | 0.295 |
| C | 3.81 | 5.08 | 0.150 | 0.200 |
| D | 0.38 | 0.56 | 0.015 | 0.022 |
| F | 1.40 | 1.65 | 0.055 | 0.065 |
| G | 2.54 BSC | | 0.100 BSC | |
| H | 0.51 | 1.27 | 0.020 | 0.050 |
| J | 0.20 | 0.30 | 0.008 | 0.012 |
| K | 3.18 | 4.06 | 0.125 | 0.160 |
| L | 7.62 BSC | | 0.300 BSC | |
| M | 0° | 15° | 0° | 15° |
| N | 0.25 | 1.02 | 0.010 | 0.040 |

**Case 738-03 N Suffix
20-Pin Plastic**

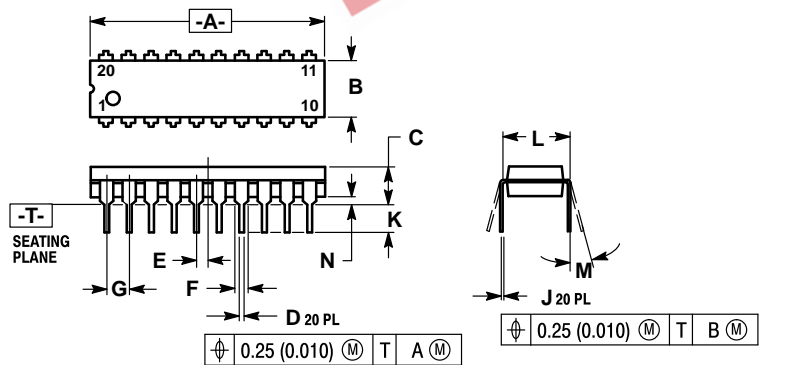

NOTES:

1. DIMENSIONING AND TOLERANCING PER ANSI Y14.5M, 1982.
2. CONTROLLING DIMENSION: INCH.
3. DIMENSION "L" TO CENTER OF LEAD WHEN FORMED PARALLEL.
4. DIMENSION "B" DOES NOT INCLUDE MOLD FLASH.
5. 738-02 OBSOLETE, NEW STANDARD 738-03.

| DIM | MILLIMETERS | | INCHES | |
|-----|-------------|-------|-----------|-------|
| | MIN | MAX | MIN | MAX |
| A | 25.66 | 27.17 | 1.010 | 1.070 |
| B | 6.10 | 6.60 | 0.240 | 0.260 |
| C | 3.81 | 4.57 | 0.150 | 0.180 |
| D | 0.39 | 0.55 | 0.015 | 0.022 |
| E | 1.27 BSC | | 0.050 BSC | |
| F | 1.27 | 1.77 | 0.050 | 0.070 |
| G | 2.54 BSC | | 0.100 BSC | |
| J | 0.21 | 0.38 | 0.008 | 0.015 |
| K | 2.80 | 3.55 | 0.110 | 0.140 |
| L | 7.62 BSC | | 0.300 BSC | |
| M | 0° | 15° | 0° | 15° |
| N | 0.51 | 1.01 | 0.020 | 0.040 |

EEPW 电子產品世界
EEPW.com.cn

Motorola reserves the right to make changes without further notice to any products herein. Motorola makes no warranty, representation or guarantee regarding the suitability of its products for any particular purpose, nor does Motorola assume any liability arising out of the application or use of any product or circuit, and specifically disclaims any and all liability, including without limitation consequential or incidental damages. "Typical" parameters can and do vary in different applications. All operating parameters, including "Typicals" must be validated for each customer application by customer's technical experts. Motorola does not convey any license under its patent rights nor the rights of others. Motorola products are not designed, intended, or authorized for use as components in systems intended for surgical implant into the body, or other applications intended to support or sustain life, or for any other application in which the failure of the Motorola product could create a situation where personal injury or death may occur. Should Buyer purchase or use Motorola products for any such unintended or unauthorized application, Buyer shall indemnify and hold Motorola and its officers, employees, subsidiaries, affiliates, and distributors harmless against all claims, costs, damages, and expenses, and reasonable attorney fees arising out of, directly or indirectly, any claim of personal injury or death associated with such unintended or unauthorized use, even if such claim alleges that Motorola was negligent regarding the design or manufacture of the part. Motorola and  are registered trademarks of Motorola, Inc. Motorola, Inc. is an Equal Opportunity/Affirmative Action Employer.

Literature Distribution Centers:

USA: Motorola Literature Distribution; P.O. Box 20912; Phoenix, Arizona 85036.

EUROPE: Motorola Ltd.; European Literature Centre; 88 Tanners Drive, Blakelands, Milton Keynes, MK14 5BP, England.

JAPAN: Nippon Motorola Ltd.; 4-32-1, Nishi-Gotanda, Shinagawa-ku, Tokyo 141, Japan.

ASIA PACIFIC: Motorola Semiconductors H.K. Ltd.; Silicon Harbour Center, No. 2 Dai King Street, Tai Po Industrial Estate, Tai Po, N.T., Hong Kong.

| SYMBOL | SW1 | SW2 |
|--------|--------|--------|
| tPZH | Open | Closed |
| tPZL | Closed | Open |
| tPLZ | Closed | Closed |

