

HD74LS48 • BCD-to-Seven-Segment Decoder Driver (Internal Pull-up outputs)

The HD74LS48 features active high outputs for driving lamp buffers. This circuit has full ripple blanking input/output controls and a lamp test input. Display patterns for BCD input counts above 9 are unique symbols to authenticate input conditions. This circuit incorporates automatic leading and/or trailing-edge zero-blanking control (RBI and RBO). Lamp test (LT) of these types may be performed at any time when the BI/RBO node is at a high level. It contains an overriding blanking input (BI) which can be used to control the lamp intensity by pulsing or to inhibit the outputs. Inputs and outputs are entirely compatible for use with TTL or DTL logic outputs.

■ BLOCK DIAGRAM

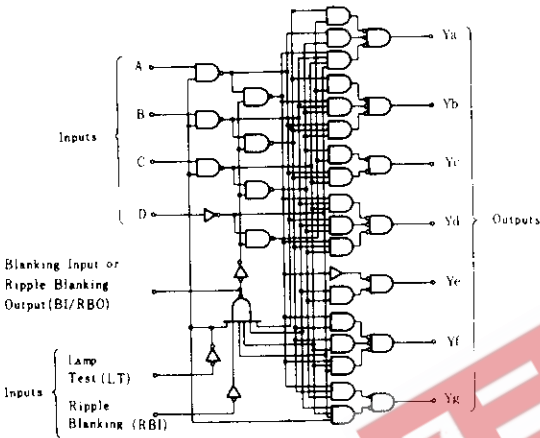

■ PIN ARRANGEMENT

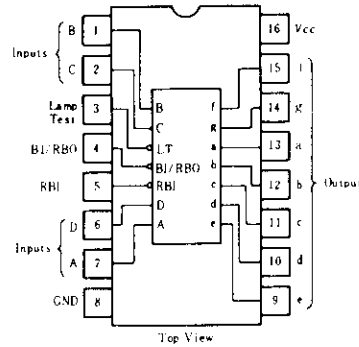

■ RECOMMENDED OPERATING CONDITIONS

Item	Symbol	min	typ	max	Unit
High level output current	a~g	—	—	-100	μ A
	BI/RBO	—	—	-50	μ A
Low level output current	a~g	—	—	6	mA
	BI/RBO	—	—	3.2	mA

■ FUNCTION TABLE

Decimal or Function	Inputs							BI RBO	Outputs							Note
	LT	RBI	D	C	B	A	a		b	c	d	e	f	g		
0	H	H	L	L	L	L	H	H	H	H	H	H	H	L		
1	H	X	L	L	L	H	H	L	H	H	L	L	L	L		
2	H	X	L	L	H	L	H	H	H	L	H	H	L	H		
3	H	X	L	L	H	H	H	H	H	H	H	L	L	H		
4	H	X	L	H	L	L	H	L	H	H	L	L	H	H		
5	H	X	L	H	L	H	H	H	L	H	H	L	H	H		
6	H	X	L	H	H	L	H	L	H	H	H	H	H	H		
7	H	X	L	H	H	H	H	H	H	H	L	L	L	L		
8	H	X	H	L	L	L	H	H	H	H	H	H	H	H		
9	H	X	H	L	L	H	H	H	H	H	L	L	H	H		
10	H	X	H	L	H	L	H	L	L	L	H	H	L	H		
11	H	X	H	L	H	H	H	L	L	H	H	L	L	H		
12	H	X	H	H	L	L	H	L	H	L	L	L	H	H		
13	H	X	H	H	L	H	H	L	L	L	H	H	H	H		
14	H	X	H	H	H	L	H	L	L	L	H	H	H	H		
15	H	X	H	H	H	H	H	L	L	L	L	L	L	L		
BI	X	X	X	X	X	X	L	L	L	L	L	L	L	L		
RBI	H	L	L	L	L	L	L	L	L	L	L	L	L	L		
LT	L	X	X	X	X	X	H	H	H	H	H	H	H	H		

H; high level, L; low level, X; irrelevant

- Notes:
- The blanking input (BI) must be open or held at a high logic level when output functions 0 through 15 are desired.
 - When a low logic level is applied directly to the blanking input (BI), all segment outputs are low regardless of the level of any other input.
 - When ripple-blanking input (RBI) and inputs A, B, C, and D are at a low level with the lamp-test input high, all segment outputs go low and the ripple-blanking output (RBO) goes to a low level (response condition).

goes to a low level (response condition).

- When a blanking input/ripple blanking output (BI/RBO) is open or held high and a low is applied to the lamp-test input, all segment outputs are high.

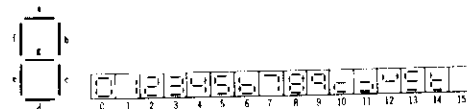

HD74LS48

ELECTRICAL CHARACTERISTICS ($T_a = -20 \sim +75^\circ\text{C}$)

Item	Symbol	Test Conditions	min	typ*	max	Unit	
Input voltage	V_{IH}		2.0	—	—	V	
	V_{IL}		—	—	0.8	V	
Output voltage	a~g BI/RBO	V_{OH}	$V_{CC}=4.75\text{V}, V_{IH}=2\text{V}, V_{IL}=0.8\text{V}$	$I_{OH} = -100\mu\text{A}$	2.4	—	V
				$I_{OH} = -50\mu\text{A}$	—	—	—
	a~g BI/RBO	V_{OL}	$V_{CC}=4.75\text{V}, V_{IH}=2\text{V}, V_{IL}=0.8\text{V}$	$I_{OL} = 2\text{mA}$	—	—	0.4
				$I_{OL} = 6\text{mA}$	—	—	0.5
Output current **	a~g	I_o	$V_{CC}=4.75\text{V}, V_o=0.85\text{V}$	$I_{OL} = 1.6\text{mA}$	—	—	0.4
				$I_{OL} = 3.2\text{mA}$	—	—	0.5
Input current	except BI/RBO	I_{IH}	$V_{CC}=5.25\text{V}, V_i=2.7\text{V}$	—	—	20	μA
		I_{IL}	$V_{CC}=5.25\text{V}, V_i=0.4\text{V}$	—	—	-0.4	mA
	BI/RBO	I_i	$V_{CC}=5.25\text{V}, V_i=0.4\text{V}$	—	—	-1.2	mA
	except BI/RBO	I_i	$V_{CC}=5.25\text{V}, V_i=7\text{V}$	—	—	0.1	mA
Short-circuit output current	BI/RBO	I_{OS}	$V_{CC}=5.25\text{V}$	-0.3	—	-2	mA
Supply current ***		I_{CC}	$V_{CC}=5.25\text{V}$	—	25	38	mA
Input clamp voltage		V_{IK}	$V_{CC}=4.75\text{V}, I_{IN} = -18\text{mA}$	—	—	-1.5	V

* $V_{CC}=5\text{V}, T_a=25^\circ\text{C}$

** Input condition as for V_{OH}

*** I_{CC} is measured with all outputs open and all inputs at 4.5V.

SWITCHING CHARACTERISTICS ($V_{CC}=5\text{V}, T_a=25^\circ\text{C}$)

Item	Symbol	Input	Test Conditions	min	typ	max	Unit
Propagation delay time	t_{PHL}	A	$C_L=15\text{pF}, R_L=4\text{k}\Omega$	—	—	100	ns
	t_{PLH}			—	—	100	
	t_{PHL}	RBI	$C_L=15\text{pF}, R_L=6\text{k}\Omega$	—	—	100	ns
	t_{PLH}			—	—	100	

TESTING METHOD

1) Test Circuit

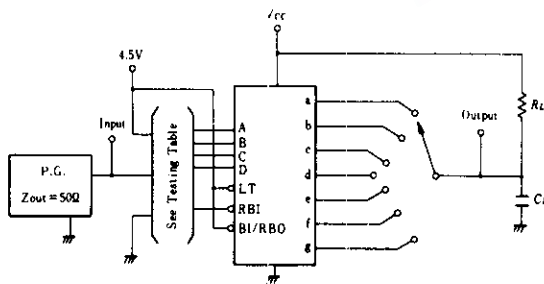

Waveform

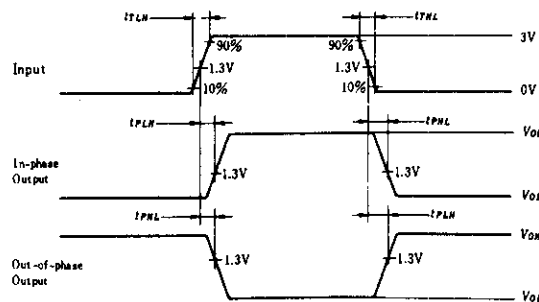

2) Testing Table

Item	Inputs					Outputs						
	RBI	D	C	B	A	a	b	c	d	e	f	g
	4.5V	GND	GND	GND	IN	OUT	—	—	OUT	OUT	OUT	—
t_{PLH}	4.5V	GND	GND	4.5V	IN	—	—	OUT	—	OUT	—	—
t_{PHL}	4.5V	GND	4.5V	4.5V	IN	OUT	OUT	—	OUT	OUT	OUT	OUT
	IN	GND	GND	GND	GND	OUT	OUT	OUT	OUT	OUT	OUT	—

Unit: mm

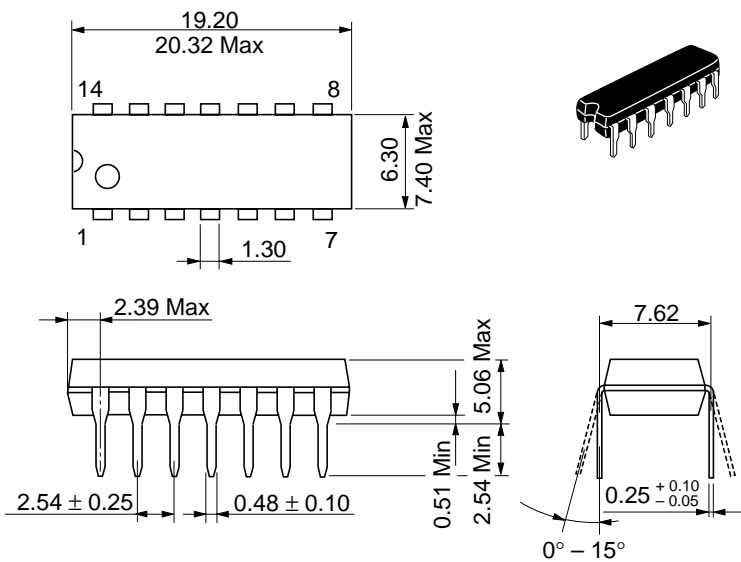

Hitachi Code	DP-14
JEDEC	Conforms
EIAJ	Conforms
Weight (reference value)	0.97 g

Unit: mm

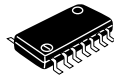
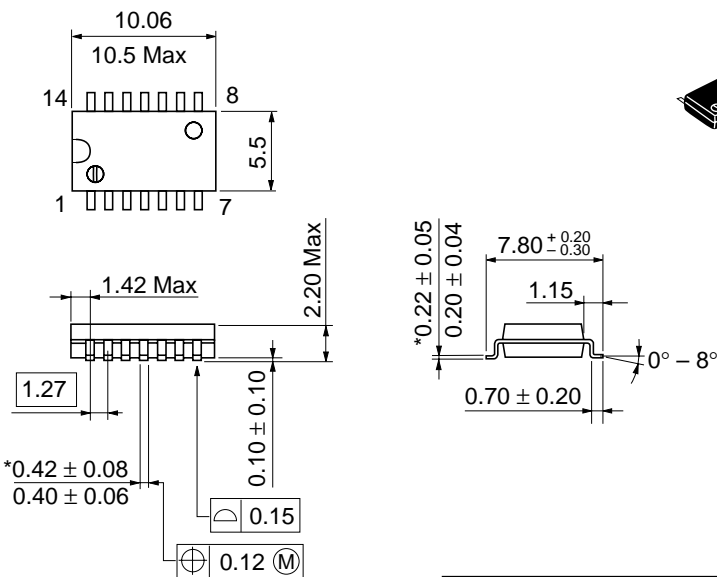

Hitachi Code	FP-14DA
JEDEC	—
EIAJ	Conforms
Weight (reference value)	0.23 g

*Dimension including the plating thickness
Base material dimension

EEPW 电子产品世界 .com.cn

Unit: mm

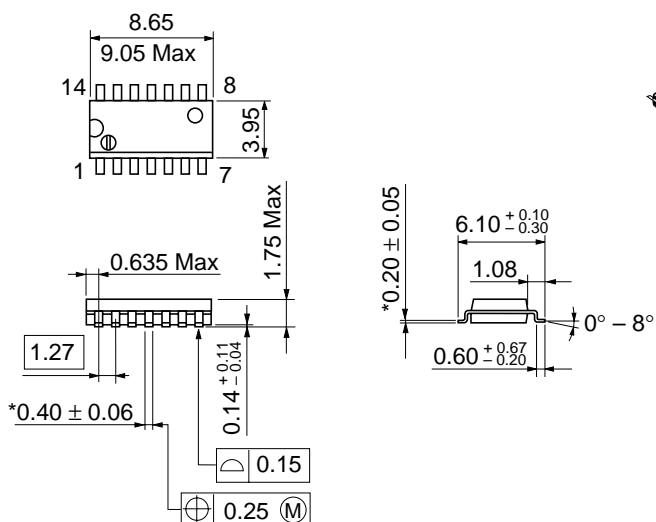

Hitachi Code	FP-14DN
JEDEC	Conforms
EIAJ	Conforms
Weight (reference value)	0.13 g

*Pd plating

Cautions

1. Hitachi neither warrants nor grants licenses of any rights of Hitachi's or any third party's patent, copyright, trademark, or other intellectual property rights for information contained in this document. Hitachi bears no responsibility for problems that may arise with third party's rights, including intellectual property rights, in connection with use of the information contained in this document.
2. Products and product specifications may be subject to change without notice. Confirm that you have received the latest product standards or specifications before final design, purchase or use.
3. Hitachi makes every attempt to ensure that its products are of high quality and reliability. However, contact Hitachi's sales office before using the product in an application that demands especially high quality and reliability or where its failure or malfunction may directly threaten human life or cause risk of bodily injury, such as aerospace, aeronautics, nuclear power, combustion control, transportation, traffic, safety equipment or medical equipment for life support.
4. Design your application so that the product is used within the ranges guaranteed by Hitachi particularly for maximum rating, operating supply voltage range, heat radiation characteristics, installation conditions and other characteristics. Hitachi bears no responsibility for failure or damage when used beyond the guaranteed ranges. Even within the guaranteed ranges, consider normally foreseeable failure rates or failure modes in semiconductor devices and employ systemic measures such as fail-safes, so that the equipment incorporating Hitachi product does not cause bodily injury, fire or other consequential damage due to operation of the Hitachi product.
5. This product is not designed to be radiation resistant.
6. No one is permitted to reproduce or duplicate, in any form, the whole or part of this document without written approval from Hitachi.
7. Contact Hitachi's sales office for any questions regarding this document or Hitachi semiconductor products.

HITACHI

Hitachi, Ltd.

Semiconductor & Integrated Circuits.
Nippon Bldg., 2-6-2, Ohte-machi, Chiyoda-ku, Tokyo 100-0004, Japan
Tel: Tokyo (03) 3270-2111 Fax: (03) 3270-5109

URL North America : <http://semiconductor.hitachi.com/>
 Europe : <http://www.hitachi-eu.com/hel/ecg>
 Asia (Singapore) : <http://www.has.hitachi.com.sg/grp3/sicd/index.htm>
 Asia (Taiwan) : http://www.hitachi.com.tw/E/Product/SICD_Frame.htm
 Asia (HongKong) : <http://www.hitachi.com.hk/eng/bo/grp3/index.htm>
 Japan : <http://www.hitachi.co.jp/Sicd/indx.htm>

For further information write to:

Hitachi Semiconductor
(America) Inc.
179 East Tasman Drive,
San Jose, CA 95134
Tel: <1> (408) 433-1990
Fax: <1> (408) 433-0223

Hitachi Europe GmbH
Electronic components Group
Dornacher StraÙe 3
D-85622 Feldkirchen, Munich
Germany
Tel: <49> (89) 9 9180-0
Fax: <49> (89) 9 29 30 00

Hitachi Europe Ltd.
Electronic Components Group.
Whitebrook Park
Lower Cookham Road
Maidenhead
Berkshire SL6 8YA, United Kingdom
Tel: <44> (1628) 585000
Fax: <44> (1628) 778322

Hitachi Asia Pte. Ltd.
16 Collyer Quay #20-00
Hitachi Tower
Singapore 049318
Tel: 535-2100
Fax: 535-1533

Hitachi Asia Ltd.
Taipei Branch Office
3F, Hung Kuo Building, No.167,
Tun-Hwa North Road, Taipei (105)
Tel: <886> (2) 2718-3666
Fax: <886> (2) 2718-8180

Hitachi Asia (Hong Kong) Ltd.
Group III (Electronic Components)
7/F., North Tower, World Finance Centre,
Harbour City, Canton Road, Tsim Sha Tsui,
Kowloon, Hong Kong
Tel: <852> (2) 735 9218
Fax: <852> (2) 730 0281
Telex: 40815 HITEC HX

Copyright ' Hitachi, Ltd., 1999. All rights reserved. Printed in Japan.

HITACHI