

74F161A, 74F163A Synchronous Presettable Binary Counter

Features

- Synchronous counting and loading
- High-speed synchronous expansion
- Typical count frequency of 120MHz

General Description

The 74F161A and 74F163A are high-speed synchronous modulo-16 binary counters. They are synchronously presettable for application in programmable dividers and have two types of Count Enable inputs plus a Terminal Count output for versatility in forming synchronous multi-stage counters. The 74F161A has an asynchronous Master-Reset input that overrides all other inputs and forces the outputs LOW. The 74F163A has a Synchronous Reset input that overrides counting and parallel loading and allows the outputs to be simultaneously reset on the rising edge of the clock. The 74F161A and 74F163A are high-speed versions of the 74F161 and 74F163.

Ordering Information

Order Number	Package Number	Package Description
74F161ASC	M16A	16-Lead Small Outline Integrated Circuit (SOIC), JEDEC MS-012, 0.150" Narrow
74F161ASJ	M16D	16-Lead Small Outline Package (SOP), EIAJ TYPE II, 5.3mm Wide
74F161APC	N16E	16-Lead Plastic Dual-In-Line Package (PDIP), JEDEC MS-001, 0.300" Wide
74F163ASC	M16A	16-Lead Small Outline Integrated Circuit (SOIC), JEDEC MS-012, 0.150" Narrow
74F163ASJ	M16D	16-Lead Small Outline Package (SOP), EIAJ TYPE II, 5.3mm Wide
74F163APC	N16E	16-Lead Plastic Dual-In-Line Package (PDIP), JEDEC MS-001, 0.300" Wide

Device also available in Tape and Reel. Specify by appending suffix letter "X" to the ordering number.

Connection Diagrams

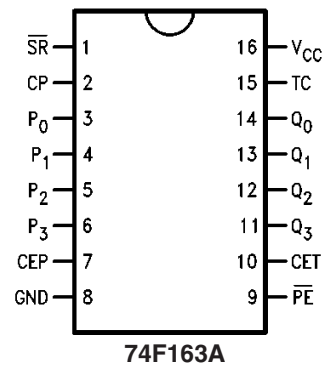
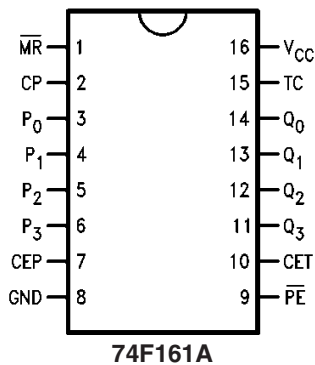

Logic Symbols

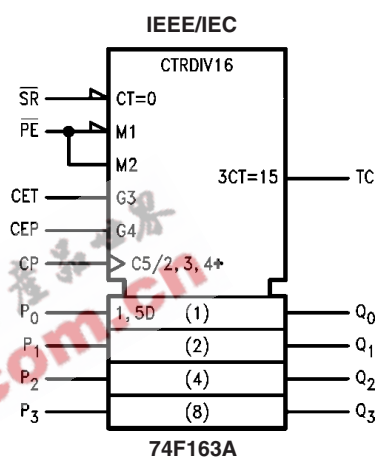
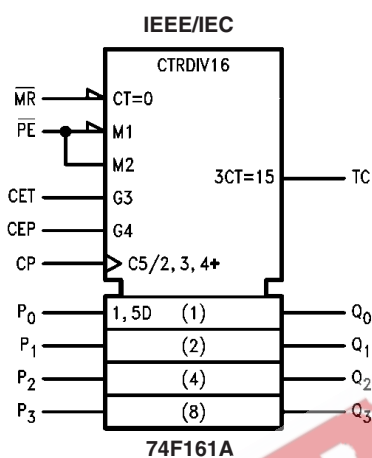
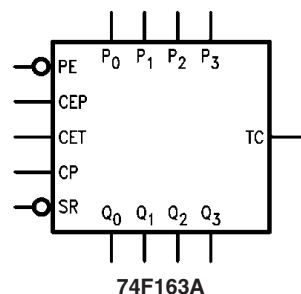
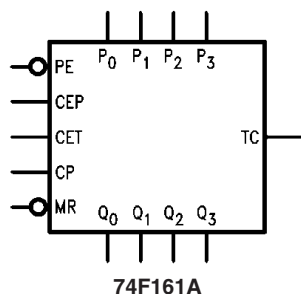

Unit Loading/Fan Out

Pin Names	Description	U.L. HIGH / LOW	Input I _{IH} / I _{IL} Output I _{OH} / I _{OL}
CEP	Count Enable Parallel Input	1.0 / 1.0	20μA / -0.6mA
CET	Count Enable Trickle Input	1.0 / 2.0	20μA / -1.2mA
CP	Clock Pulse Input (Active Rising Edge)	1.0 / 1.0	20μA / -0.6 mA
$\overline{\text{MR}}$ (74F161A)	Asynchronous Master Reset Input (Active LOW)	1.0 / 1.0	20μA / -0.6 mA
$\overline{\text{SR}}$ (74F163A)	Synchronous Reset Input (Active LOW)	1.0 / 2.0	20μA / -1.2 mA
P ₀ -P ₃	Parallel Data Inputs	1.0 / 1.0	20μA / -0.6 mA
$\overline{\text{PE}}$	Parallel Enable Input (Active LOW)	1.0 / 2.0	20μA / -1.2mA
Q ₀ -Q ₃	Flip-Flop Outputs	50 / 33.3	-1mA / 20mA
TC	Terminal Count Output	50 / 33.3	-1mA / 20mA

Functional Description

The 74F161A and 74F163A count in modulo-16 binary sequence. From state 15 (HHHH) they increment to state 0 (LLLL). The clock inputs of all flip-flops are driven in parallel through a clock buffer. Thus all changes of the Q outputs (except due to Master Reset of the 74F161A) occur as a result of, and synchronous with, the LOW-to-HIGH transition of the CP input signal. The circuits have four fundamental modes of operation, in order of precedence: asynchronous reset (74F161A), synchronous reset (74F163A), parallel load, count-up and hold. Five control inputs—Master Reset (\overline{MR} , 74F161A), Synchronous Reset (\overline{SR} , 74F163A), Parallel Enable (\overline{PE}), Count Enable Parallel (CEP) and Count Enable Trickle (CET)—determine the mode of operation, as shown in the Mode Select Table. A LOW signal on \overline{MR} overrides all other inputs and asynchronously forces all outputs LOW. A LOW signal on \overline{SR} overrides counting and parallel loading and allows all outputs to go LOW on the next rising edge of CP. A LOW signal on \overline{PE} overrides counting and allows information on the Parallel Data (P_n) inputs to be loaded into the flip-flops on the next rising edge of CP. With \overline{PE} and \overline{MR} (74F161A) or \overline{SR} (74F163A) HIGH, CEP and CET permit counting when both are HIGH. Conversely, a LOW signal on either CEP or CET inhibits counting.

The 74F161A and 74F163A use D-type edge triggered flip-flops and changing the \overline{SR} , \overline{PE} , CEP and CET inputs when the CP is in either state does not cause errors, provided that the recommended setup and hold times, with respect to the rising edge of CP, are observed.

The Terminal Count (TC) output is HIGH when CET is HIGH and the counter is in state 15. To implement synchronous multi-stage counters, the TC outputs can be used with the CEP and CET inputs in two different ways. Please refer to the 74F568 data sheet. The TC output is subject to decoding spikes due to internal race conditions and is therefore not recommended for use as a clock or asynchronous reset for flip-flops, counters or registers.

Logic Equations:

$$\text{Count Enable} = \text{CEP} \cdot \text{CET} \cdot \overline{\text{PE}}$$

$$\text{TC} = Q_0 \cdot Q_1 \cdot Q_2 \cdot Q_3 \cdot \text{CET}$$

Mode Select Table

$\overline{SR}^{(1)}$	\overline{PE}	CET	CEP	Action on the Rising Clock Edge (\nearrow)
L	X	X	X	Reset (Clear)
H	L	X	X	Load ($P_n \rightarrow Q_n$)
H	H	H	H	Count (Increment)
H	H	L	X	No Change (Hold)
H	H	X	L	No Change (Hold)

H = HIGH Voltage Level

L = LOW Voltage Level

X = Immaterial

Note:

1. For 74F163A only

State Diagram

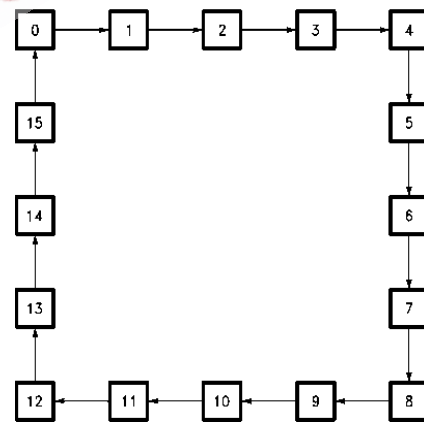

Block Diagram

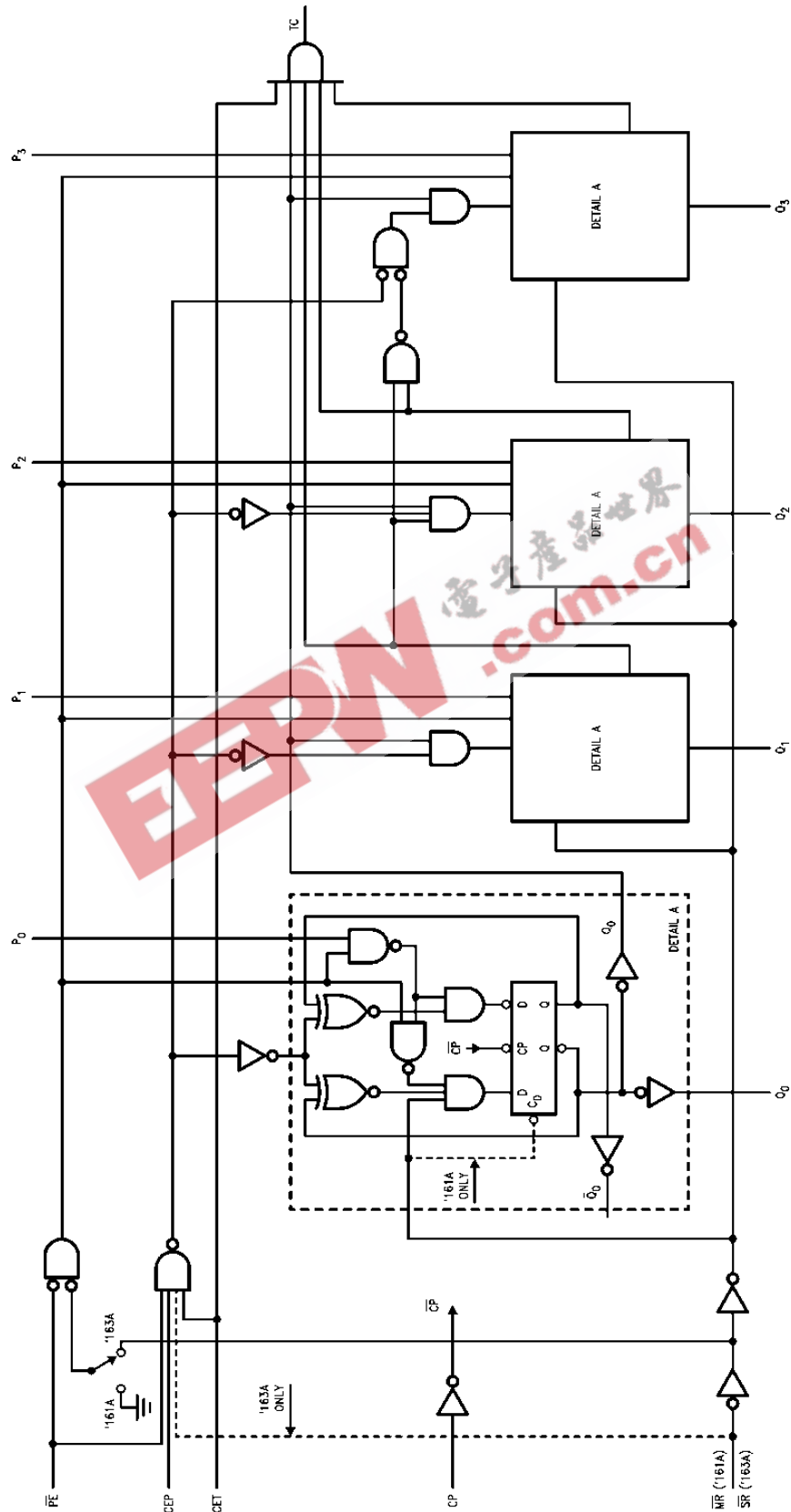

Figure 1.

Absolute Maximum Ratings

Stresses exceeding the absolute maximum ratings may damage the device. The device may not function or be operable above the recommended operating conditions and stressing the parts to these levels is not recommended. In addition, extended exposure to stresses above the recommended operating conditions may affect device reliability. The absolute maximum ratings are stress ratings only.

Symbol	Parameter	Rating
T_{STG}	Storage Temperature	-65°C to +150°C
T_A	Ambient Temperature Under Bias	-55°C to +125°C
T_J	Junction Temperature Under Bias	-55°C to +150°C
V_{CC}	V_{CC} Pin Potential to Ground Pin	-0.5V to +7.0V
V_{IN}	Input Voltage ⁽²⁾	-0.5V to +7.0V
I_{IN}	Input Current ⁽²⁾	-30mA to +5.0mA
V_O	Voltage Applied to Output in HIGH State (with $V_{CC} = 0V$)	
	Standard Output	-0.5V to V_{CC}
	3-STATE Output	-0.5V to +5.5V
	Current Applied to Output in LOW State (Max.)	twice the rated I_{OL} (mA)
	ESD Last Passing Voltage (Min.)	4000V

Note:

2. Either voltage limit or current limit is sufficient to protect inputs.

Recommended Operating Conditions

The Recommended Operating Conditions table defines the conditions for actual device operation. Recommended operating conditions are specified to ensure optimal performance to the datasheet specifications. Fairchild does not recommend exceeding them or designing to absolute maximum ratings.

Symbol	Parameter	Rating
T_A	Free Air Ambient Temperature	0°C to +70°C
V_{CC}	Supply Voltage	+4.5V to +5.5V

DC Electrical Characteristics

Symbol	Parameter	V _{CC}	Conditions	Min.	Typ.	Max.	Units
V _{IH}	Input HIGH Voltage		Recognized as a HIGH Signal	2.0			V
V _{IL}	Input LOW Voltage		Recognized as a LOW Signal			0.8	V
V _{CD}	Input Clamp Diode Voltage	Min.	I _{IN} = -18mA			-1.2	V
V _{OH}	Output HIGH Voltage	10% V _{CC} 5% V _{CC}	Min.	2.5			V
				2.7			
V _{OL}	Output LOW Voltage	10% V _{CC}	Min.	I _{OL} = 20mA		0.5	V
I _{IH}	Input HIGH Current	Max.	V _{IN} = 2.7V			5.0	μA
I _{BVI}	Input HIGH Current Breakdown Test	Max.	V _{IN} = 7.0V			7.0	μA
I _{CEX}	Output HIGH Leakage Current	Max.	V _{OUT} = V _{CC}			50	μA
V _{ID}	Input Leakage Test	0.0	I _{ID} = 1.9μA, All Other Pins Grounded	4.75			V
I _{OD}	Output Leakage Circuit Current	0.0	V _{IOD} = 150mV, All Other Pins Grounded			3.75	μA
I _{IL}	Input LOW Current	Max.	V _{IN} = 0.5V (CEP, CP, MR, P ₀ -P ₃)			-0.6	mA
			V _{IN} = 0.5V (CET, PE, SR)			-1.2	
I _{OS}	Output Short-Circuit Current	Max.	V _{OUT} = 0.0V	-60		-150	mA
I _{CC}	Power Supply Voltage	Max.			37	55	mA

AC Electrical Characteristics

Symbol	Parameter	$T_A = +25^\circ\text{C}$, $V_{CC} = +5.0\text{V}$, $C_L = 50\text{pF}$			$T_A = -55^\circ\text{C to } +125^\circ\text{C}$, $V_{CC} = +5.0\text{V}$, $C_L = 50\text{pF}$		$T_A = 0^\circ\text{C to } 70^\circ\text{C}$, $V_{CC} = +5.0\text{V}$, $C_L = 50\text{pF}$		Units
		Min.	Typ.	Max.	Min.	Max.	Min.	Max.	
f_{MAX}	Maximum Count Frequency		100						MHz
t_{PLH}	Propagation Delay, CP to Q_n ($\overline{\text{PE}}$ Input HIGH)	3.5	5.5	7.5	3.5	9.0	3.5	8.5	ns
t_{PHL}	CP to Q_n ($\overline{\text{PE}}$ Input LOW)	3.5	7.5	10.0	3.5	11.5	3.5	11.0	
t_{PLH}	Propagation Delay, CP to Q_n ($\overline{\text{PE}}$ Input LOW)	4.0	6.0	8.5	4.0	10.0	4.0	9.5	ns
t_{PHL}	CP to TC	4.0	6.0	8.5	4.0	10.0	4.0	9.5	
t_{PLH}	Propagation Delay, CP to TC	5.0	10.0	14.0	5.0	16.5	5.0	15.0	ns
t_{PHL}	CP to TC	5.0	10.0	14.0	5.0	15.5	5.0	15.0	
t_{PLH}	Propagation Delay, CET to TC	2.5	4.5	7.5	2.5	9.0	2.5	8.5	ns
t_{PHL}	CET to TC	2.5	4.5	7.5	2.5	9.0	2.5	8.5	
t_{PHL}	Propagation Delay, $\overline{\text{MR}}$ to Q_n (74F161A)	5.5	9.0	12.0	5.5	14.0	5.5	13.0	ns
t_{PHL}	Propagation Delay, $\overline{\text{MR}}$ to TC (74F161A)	4.5	8.0	10.5	4.5	12.5	4.5	11.5	ns

AC Operating Requirements

Symbol	Parameter	$T_A = +25^\circ\text{C}$, $V_{CC} = +5.0\text{V}$		$T_A = -55^\circ\text{C to } +125^\circ\text{C}$, $V_{CC} = +5.0\text{V}$		$T_A = 0^\circ\text{C to } 70^\circ\text{C}$, $V_{CC} = +5.0\text{V}$		Units
		Min.	Max.	Min.	Max.	Min.	Max.	
$t_{\text{S}}(\text{H})$	Setup Time, HIGH or LOW, P_n to CP	5.0		5.5		5.0		ns
$t_{\text{S}}(\text{L})$	P_n to CP	5.0		5.5		5.0		
$t_{\text{H}}(\text{H})$	Hold Time, HIGH or LOW, P_n to CP	2.0		2.5		2.0		ns
$t_{\text{H}}(\text{L})$	P_n to CP	2.0		2.5		2.0		
$t_{\text{S}}(\text{H})$	Setup Time, HIGH or LOW, $\overline{\text{PE}}$ or $\overline{\text{SR}}$ to CP	11.0		13.5		11.5		ns
$t_{\text{S}}(\text{L})$	$\overline{\text{PE}}$ or $\overline{\text{SR}}$ to CP	8.5		10.5		9.5		
$t_{\text{H}}(\text{H})$	Hold Time, HIGH or LOW, $\overline{\text{PE}}$ or $\overline{\text{SR}}$ to CP	2.0		3.6		2.0		ns
$t_{\text{H}}(\text{L})$	$\overline{\text{PE}}$ or $\overline{\text{SR}}$ to CP	0		0		0		
$t_{\text{S}}(\text{H})$	Setup Time, HIGH or LOW, CEP or CET to CP	11.0		13.0		11.5		ns
$t_{\text{S}}(\text{L})$	CEP or CET to CP	5.0		6.0		5.0		
$t_{\text{H}}(\text{H})$	Hold Time, HIGH or LOW, CEP or CET to CP	0		0		0		ns
$t_{\text{H}}(\text{L})$	CEP or CET to CP	0		0		0		
$t_{\text{W}}(\text{H})$	Clock Pulse Width (Load), HIGH or LOW	5.0		5.0		5.0		ns
$t_{\text{W}}(\text{L})$	Clock Pulse Width (Load), HIGH or LOW	5.0		5.0		5.0		
$t_{\text{W}}(\text{H})$	Clock Pulse Width (Count), HIGH or LOW	4.0		5.0		4.0		ns
$t_{\text{W}}(\text{L})$	Clock Pulse Width (Count), HIGH or LOW	6.0		8.0		7.0		
$t_{\text{W}}(\text{L})$	$\overline{\text{MR}}$ Pulse Width, LOW (74F161A)	5.0		5.0		5.0		ns
t_{REC}	Recovery Time, $\overline{\text{MR}}$ to CP (74F161A)	6.0		6.0		6.0		ns

Physical Dimensions

Dimensions are in inches (millimeters) unless otherwise noted.

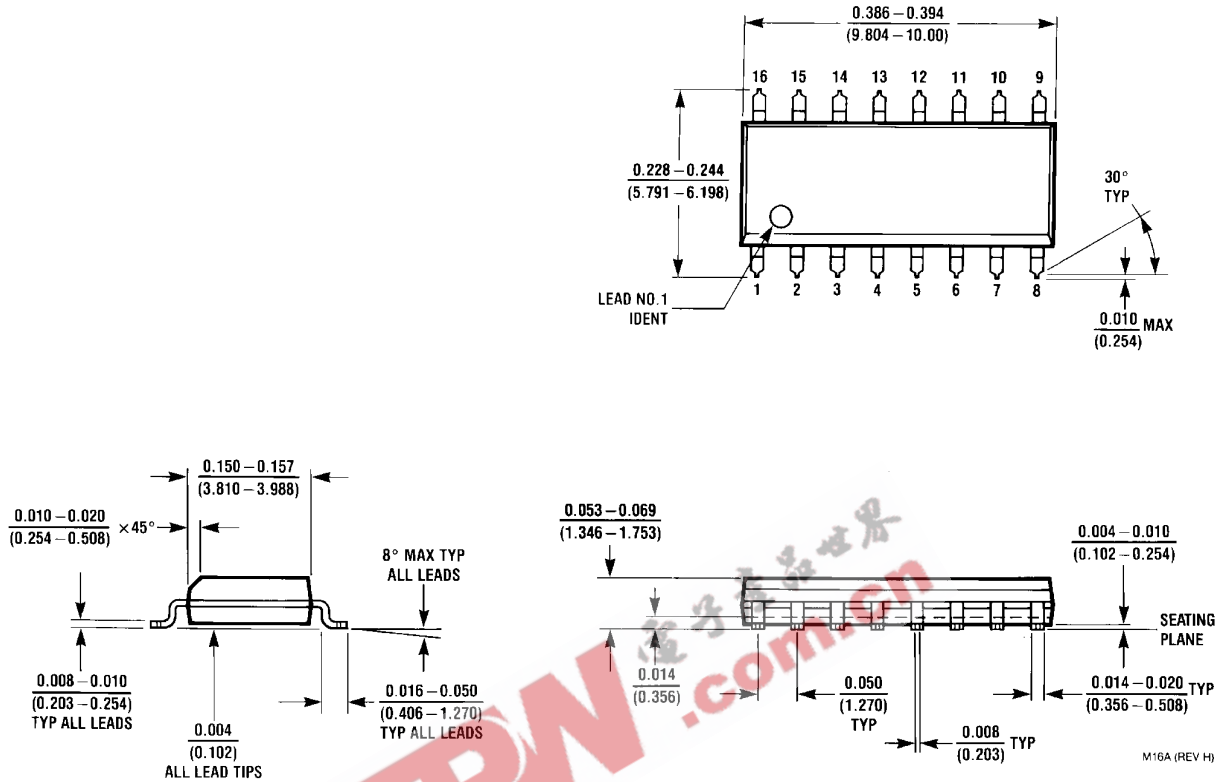
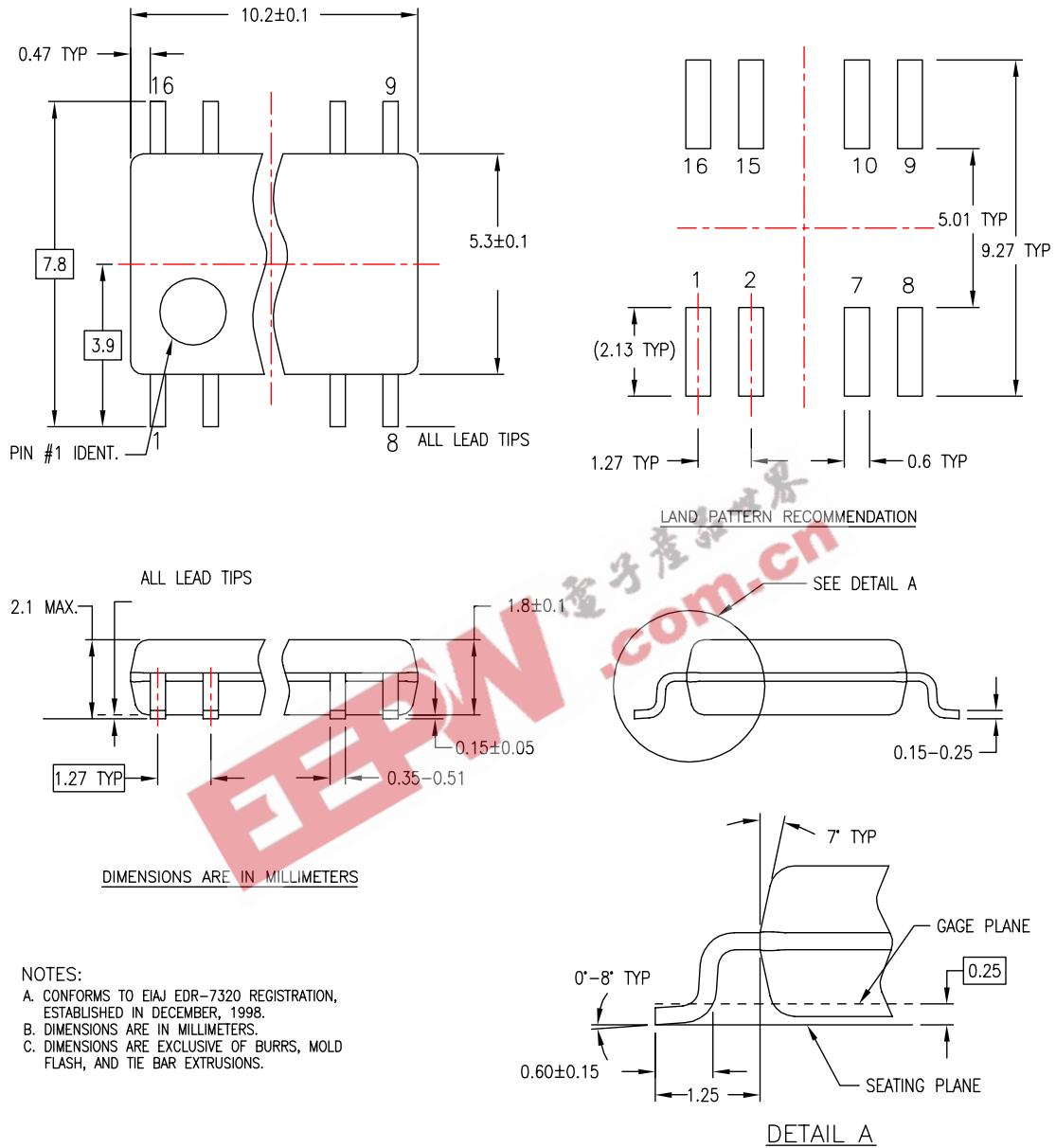

Figure 2. 16-Lead Small Outline Integrated Circuit (SOIC), JEDEC MS-012, 0.150" Narrow Package Number M16A

Physical Dimensions (Continued)

Dimensions are in millimeters unless otherwise noted.



M16DREVC

Figure 3. 16-Lead Small Outline Package (SOP), EIAJ TYPE II, 5.3mm Wide Package Number M16D

Physical Dimensions (Continued)

Dimensions are in inches (millimeters) unless otherwise noted.

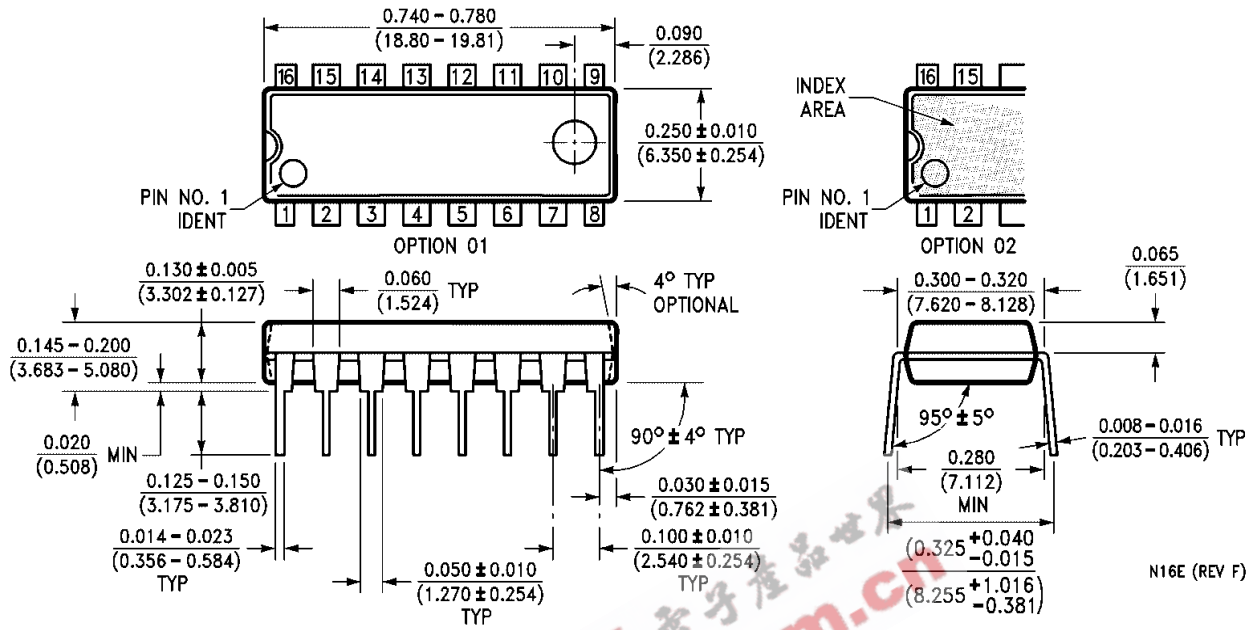



TRADEMARKS

The following are registered and unregistered trademarks Fairchild Semiconductor owns or is authorized to use and is not intended to be an exhaustive list of all such trademarks.

ACEx®	HiSeC™	Programmable Active Droop™	TinyLogic®
Across the board. Around the world.™	i-Lo™	QFET®	TINYOPTO™
ActiveArray™	ImpliedDisconnect™	QS™	TinyPower™
Bottomless™	IntelliMAX™	QT Optoelectronics™	TinyWire™
Build it Now™	ISOPLANAR™	Quiet Series™	TruTranslation™
CoolFET™	MICROCOUPLER™	RapidConfigure™	μSerDes™
CROSSVOLT™	MicroPak™	RapidConnect™	UHC®
CTL™	MICROWIRE™	ScalarPump™	UniFET™
Current Transfer Logic™	MSX™	SMART START™	VCX™
DOME™	MSXPro™	SPM®	Wire™
E ² CMOS™	OCX™	STEALTH™	
EcoSPARK®	OCXPro™	SuperFET™	
EnSigna™	OPTOLOGIC®	SuperSOT™-3	
FACT Quiet Series™	OPTOPLANAR®	SuperSOT™-6	
FACT®	PACMAN™	SuperSOT™-8	
FAST®	POP™	SyncFET™	
FASTr™	Power220®	TCM™	
FPS™	Power247®	The Power Franchise®	
FRFET®	PowerEdge™	TinyBoost™	
GlobalOptoisolator™	PowerSaver™	TinyBuck™	
GTO™	PowerTrench®		

DISCLAIMER

FAIRCHILD SEMICONDUCTOR RESERVES THE RIGHT TO MAKE CHANGES WITHOUT FURTHER NOTICE TO ANY PRODUCTS HEREIN TO IMPROVE RELIABILITY, FUNCTION OR DESIGN. FAIRCHILD DOES NOT ASSUME ANY LIABILITY ARISING OUT OF THE APPLICATION OR USE OF ANY PRODUCT OR CIRCUIT DESCRIBED HEREIN; NEITHER DOES IT CONVEY ANY LICENSE UNDER ITS PATENT RIGHTS, NOR THE RIGHTS OF OTHERS. THESE SPECIFICATIONS DO NOT EXPAND THE TERMS OF FAIRCHILD'S WORLDWIDE TERMS AND CONDITIONS, SPECIFICALLY THE WARRANTY THEREIN, WHICH COVERS THESE PRODUCTS.

LIFE SUPPORT POLICY

FAIRCHILD'S PRODUCTS ARE NOT AUTHORIZED FOR USE AS CRITICAL COMPONENTS IN LIFE SUPPORT DEVICES OR SYSTEMS WITHOUT THE EXPRESS WRITTEN APPROVAL OF FAIRCHILD SEMICONDUCTOR CORPORATION.

As used herein:

1. Life support devices or systems are devices or systems which, (a) are intended for surgical implant into the body or (b) support or sustain life, and (c) whose failure to perform when properly used in accordance with instructions for use provided in the labeling, can be reasonably expected to result in a significant injury of the user.
2. A critical component in any component of a life support, device, or system whose failure to perform can be reasonably expected to cause the failure of the life support device or system, or to affect its safety or effectiveness.

PRODUCT STATUS DEFINITIONS

Definition of Terms

Datasheet Identification	Product Status	Definition
Advance Information	Formative or In Design	This datasheet contains the design specifications for product development. Specifications may change in any manner without notice.
Preliminary	First Production	This datasheet contains preliminary data; supplementary data will be published at a later date. Fairchild Semiconductor reserves the right to make changes at any time without notice to improve design.
No Identification Needed	Full Production	This datasheet contains final specifications. Fairchild Semiconductor reserves the right to make changes at any time without notice to improve design.
Obsolete	Not In Production	This datasheet contains specifications on a product that has been discontinued by Fairchild Semiconductor. The datasheet is printed for reference information only.

Rev. I24